

# XVME-653

## VMEbus Pentium® Processor Module

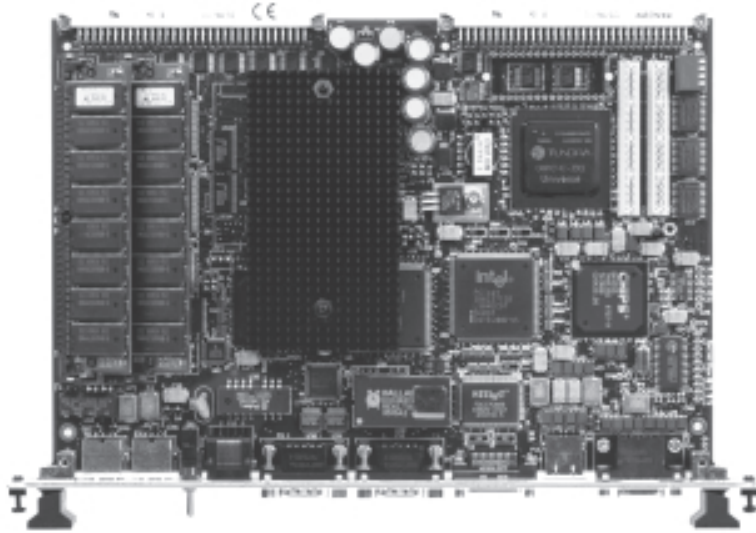

### Features

- 233 MHz Pentium® processor with MMX™ technology
- Supports up to 256 MB of fast-page or EDO DRAM in 72-pin SIMM sites, with ECC or parity
- 512K of synchronous Level 2 pipeline cache
- High-performance PCI local bus SVGA controller with 2 MB of VRAM
- PCI Enhanced IDE controller with DMA
- 10/100 Mbit PCI Ethernet controller with front RJ-45 connector
- Up to 72 MB of optional flash disk storage
- PCI-to-VMEbus interface with DMA
- Two high-speed 16550-compatible serial ports
- Universal Serial Bus (USB) port
- EPP or ECP parallel port
- PS/2-style keyboard and mouse ports
- Configurable hardware byte-swapping logic

### Overview

The XVME-653 is a powerful VMEbus PC compatible processor module from Xycom Automation, the pioneer and leader in VMEbus PC technology. This powerful single-slot VMEbus processor integrates a 233 MHz MMX Pentium CPU with a PCI-to-VMEbus interface and allows users to take advantage of the powerful multiprocessing capability of the VMEbus while utilizing standard off-the-shelf PC software and operating systems.

At the core of the XVME-653 module is the Intel 233MHz MMX CPU combined with 512K of synchronous Level 2 pipeline cache and up to 256 MB of fast-page or EDO DRAM.

The module contains a wide breadth of I/O including PCI Graphics, EIDE and Ethernet controllers, one Universal Serial Bus (USB) Port, two high-speed serial ports, one EPP/ECP parallel port, and PS/2 style keyboard and mouse ports. Further I/O expansion is available using Xycom Automation's modular I/O carrier modules (XVME-976), which provide a mechanism to expand your system using PMC, PC/104, short ISA or PCI modules.

The XVME-653 module is an unbeatable solution for power and I/O on a single-slot VMEbus module.

The XVME-653 features a high-performance, highly integrated Intel chipset that incorporates a host-to-PCI bus interface and PCI-to-ISA bridge with Universal Serial Bus host controller.

### ***Display Support***

Graphics support is provided by a highly integrated SVGA controller with an internal 2 MB 83 MHz SDRAM frame buffer. Resolutions of up to 1280 × 1024 with 256 colors are supported. The controller uses a 64-bit internal graphics engine with hardware BitBLT to enhance Windows GUI performance. SVGA output is available at the module front panel in standard 15-pin D shell connector.

### ***Network Support***

The XVME-653 contains a state-of-the-art Intel 82558 10/100 Mbit Ethernet controller with a 32-bit PCI bus mastering interface to support bus transfers of 100 Mbits per second. The RJ-45 connector on the module's front panel provides autosensing for 10 BaseT and 100 BaseTX connections.

### ***VMEbus Interface***

The PCI-to-VMEbus bridge device provides users with a flexible mapping architecture to allow configurations that will support virtually all user applications. The bridge device supports multiple VME master and slave images with BLT and DMA capability for high-performance block data operations.

The XVME-653 also contains onboard hardware byte-swapping.

### ***Expansion***

A variety of expansion modules are available for use with the XVME-653. The XVME-976 expansion modules allow users of the XVME-653 to expand their systems by using PMC, PC/104, short ISA or PCI modules.

### ***Mass Storage Support***

Floppy and hard drive functions are supported by bus mastering EIDE and PC-compatible controllers. Signals for both the floppy and EIDE interfaces are routed to the A and C rows of the module's P2 connector, allowing the XVME-653 to access a variety of mass-storage options. These options include single-slot hard and floppy disk modules (XVME-977), solid-state mass storage modules or externally mounted mass storage devices using the XVME-973 drive adaptor module.

### ***Nonvolatile Storage***

An onboard 32-pin socket provides nonvolatile storage with zero-power SRAM or an M-Systems DiskOnChip® flash disk. The DiskOnChip® flash disk (XVME-992) will provide up to 72 MB of solid-state disk storage for embedded applications.

### ***I/O Support***

Other functions provided on the XVME-653 include one Universal Serial Bus (USB) port, two 16550-compatible RS-232C serial ports, one ECP/EPP parallel port, and PS/2 style keyboard and mouse ports. All connections to these ports are available on the front panel.

### ***Software Support***

Even with all of the power and features packed into the XVME-653, a processor board is only as good as its support software. Although the XVME-653 is fully PC-compatible and will run "off-the-shelf" PC software, most packages will not be able to access the features of the VMEbus. To solve this problem, Xycom Automation has developed extensive Board Support Packages (BSPs) that simplify the integration of VMEbus data into PC software applications. Xycom Automation's BSPs provide users with an efficient high-level interface between their applications and the VMEbus-to-PCI bridge device. Board Support Packages are available for MS-DOS, Windows NT®, LynxOS, Solaris™, QNX®, and VxWorks®.

# XVME-653 Block Diagram

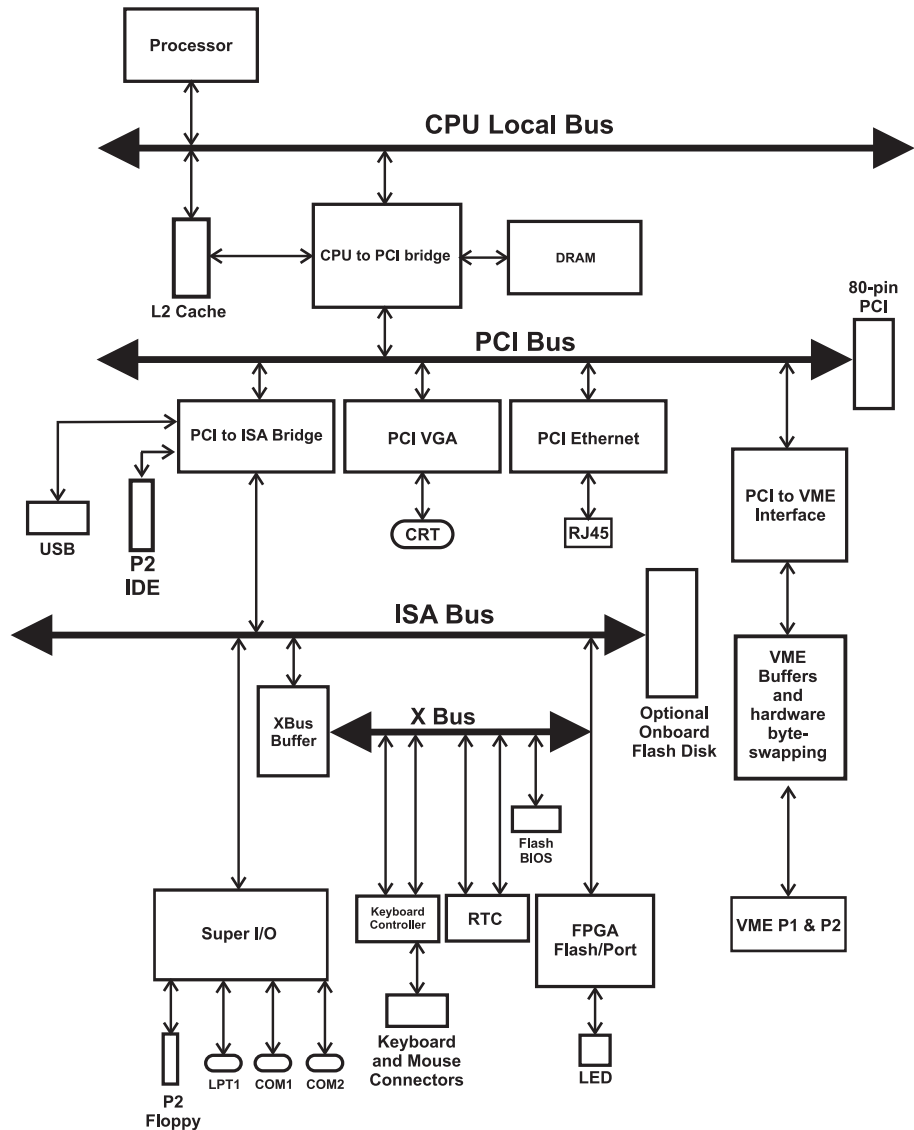

## Hardware Specifications

### CPU

233 MHz Pentium processor with MMX technology

### PCI Super VGA Graphics Controller

1280 × 1024; 256 colors

2 MB VRAM

### PCI Ethernet Controller

Intel 82558 Controller

10/100 Mbps Fast Ethernet

RJ-45 Connector on module front panel

### Serial Ports

Two RS-232C-compatible

One Universal Serial Bus port

### Parallel Interface

One EPP/ECP compatible

### Onboard Memory

Fast-page or EDO DRAM, 32 MB to 256 MB

### Cache

512K pipeline burst cache

### Power Specifications<sup>a</sup>

10.59 amps (max.), 5.87 amps (typical)

<sup>a</sup>Requires VME P2 Backplane

## Environmental Specifications

### Temperature

Operating	0°-50° C with 100 CFM airflow
Nonoperating	-40 to 85° C

### Vibration

Frequency	5 to 2000 Hz
Operating	.015" (.38 mm) peak-to-peak displacement 2.5 g (maximum) acceleration
Nonoperating	.030" (.76 mm) peak-to-peak displacement 5.0 g (maximum) acceleration

### Shock

Operating	30 g peak acceleration 11 msec duration
Nonoperating	50 g peak acceleration 11 msec duration

### Humidity

Operating	20% to 80% RH, noncondensing
Nonoperating	20% to 80% RH, noncondensing

## Warranty

The XVME-653 carries a two-year parts and labor warranty.

## VMEbus Compliance

- Complies with VMEbus Specification, ANSI/VITA 1-1994
- A32/A24/A16:D64/D32/D16/D08(EO) DTB Master
- A32/A24:D64/D32/D16/D08(EO) DTB Slave
- R(0-3) Bus Requester
- Interrupter I(1)-I(7) DYN
- IH(1)-IH(7) Interrupt Handler
- SYSCLK and SYSRESET Driver
- PRI, SGL, RRS Arbiter
- RWD, ROR bus release
- Form Factor: DOUBLE  
233 mm × 160 mm (9.2" × 6.3")

## Ordering Information

XVME-653/31x	233 MHz MMX™ Pentium VMEbus PC Processor with 512K cache, configurable hardware byte-swapping
where: x=0	No DRAM
x=3	32 MB DRAM
x=4	64 MB DRAM
x=5	128 MB DRAM
x=6	256 MB DRAM
XVME-973/1	Drive Adapter Module for external drives
XVME-976/201	PMC/PC/104 Expansion Module
XVME-976/202	16-bit short ISA Expansion Module
XVME-976/203	Dual PMC Expansion Module
XVME-976/204	Dual PC/104 Expansion Module
XVME-976/205	PCI Carrier Module
XVME-977	Single-slot Mass Storage Module
XVME-992/8	8 MB DiskOnChip®
XVME-992/24	24 MB DiskOnChip®
XVME-992/40	40 MB DiskOnChip®
XVME-992/72	72 MB DiskOnChip®

**XYCOM AUTOMATION, INC.** 750 North Maple Road  
Saline, Michigan 48176-1292  
Phone: (734) 429-4971  
FAX: (734) 429-1010  
Call toll-free: 1-800-AT-XYCOM  
<http://www.xycomautomation.com/>

**XYCOM AUTOMATION CANADA, INC.** 3490 Laird Road, Suite 11  
Mississauga, Ontario L5L 5Y4 Canada  
Phone: (905) 825-0281  
FAX: (905) 825-0282

**XYCOM AUTOMATION LTD.**  
**NORTHERN EUROPE**  
21 Tenter Road, Moulton Park  
Northampton NN3 6AX England  
Phone: +44-1604-790-767  
FAX: +44-1604-790-722

**XYCOM AUTOMATION S.r.L.**  
**SOUTHERN EUROPE**  
Via Chambery 93/107/U  
10142 Torino, Italy  
Phone: 39-011-770-5311  
FAX: 39-011-770-53270