

VMIVME-2120*

Specifications

64-bit High Voltage Digital Output with Built-in-Test

Features:

- 64 bits of high voltage outputs
- High current drivers (600mA sink)
- Automatic surge current shutdown protection option
- Thermal shutdown protection option for driving incandescent or inductive loads
- High breakdown voltage (55V)
- Output clamp diodes for inductive flyback protection
- Compatible with Intelligent I/O Controllers
- Built-in-Test logic for fault isolation
- High reliability DIN-type I/O connectors
- 8-, 16-, or 32-bit transfers
- Double Eurocard form factor
- Separate board address decoding for control and data registers
- Optional pull-up resistors for electronic switch outputs
- Optional TTL outputs
- Front panel with fail LED



Ordering Options						
August 12, 2010 800-002120-000 K	A	B	C	D	E	F
VMIVME-2120	-			0	0	0

A = Data Polarity

- 1 = Positive True
- 2 = Negative True

B = Output Type

- 0 = Logic Level (TTL Compatible), Automatic Surge Current Shutdown Protection
- 1 = High Voltage Level (Open Collector), Automatic Surge Current Shutdown Protection ⁽¹⁾
- 2 = Electronic Switch Option, Automatic Surge Current Shutdown Protection
- 3 = Logic Level (TTL Compatible), No Shutdown Protection
- 4 = High Voltage Level (Open Collector), No Shutdown Protection ⁽¹⁾
- 5 = Electronic Switch Option, No Shutdown Protection
- 6 = Logic Level (TTL Compatible), Thermal Shutdown Protection ⁽²⁾
- 7 = High Voltage Level (Open Collector), Thermal Shutdown Protection ⁽¹⁾⁽²⁾
- 8 = Electronic Switch Option, Thermal Shutdown Protection ⁽²⁾

C = Pull-Up Resistors; Output Voltage Range ⁽³⁾

- 0 = 270 Ω, 5V Range (6V Absolute Maximum)
- 1 = 1.5 K, 12V Range (14V Absolute Maximum)
- 2 = 6.8 K, 24V Range (30V Absolute Maximum)
- 3 = 27 K, 48V Range (55V Absolute Maximum)
- 4 = 560 Ω, 5V Range (8V Absolute Maximum)⁽⁴⁾
- 5 = No Pull-Up Resistor Installed (55V Absolute Maximum)

D = 0 (Option reserved for future use)

E = 0 (Option reserved for future use)

F = 0 (Option reserved for future use)

Connector Data

Compatible Cable Connector	Panduit No. 120-964-435 ⁽⁵⁾
PC Board Connector	Panduit No. 120-964-033A
Strain Relief Device	Panduit No. 100-000-072

Notes

1. No pull-up resistors installed, C option field must equal 5.
2. Required for driving incandescent lamps without external warming or current limiting resistors.
3. The absolute maximum output voltage is determined by the power dissipation of the pull-up resistor (0.12W maximum) and by the output driver. The maximum voltage with no latch-up is 35V. Please note the open-collector options (output types 1, 4, and 7) take precedence (that is, no pull-up resistor is installed for those types regardless of output voltage range selected).
4. TTL-compatible option, used with output type *Logic Level* 0, 3, and 6.
5. Panduit is also known as ITW/Pancon.

For Ordering Information, Call:
1-800-322-3616 or 1-256-880-0444 • FAX (256) 882-0859

Email: info.embeddedsystems.ip@ge.com

Web Address: www.ge-ip.com

Copyright © 2010 GE Intelligent Platforms Embedded Systems, Inc.
All Rights Reserved.

Specifications subject to change without notice.

Functional Characteristics

Compatibility: VMEbus specification compatible. Double height form factor.

Output Connector Type: Dual 64-pin connectors - DIN 41612

Output Organization: Eight ports, eight bits wide. Addressable to any address within short supervisory or short nonprivileged I/O map. Control and Status Register (CSR) address is independently selectable.

Address Modifier Codes: Jumper-selectable for short supervisory or short nonprivileged I/O access. Factory configured for short supervisory I/O access.

Addressing Scheme: Eight ports individually addressable on 8-, 16-, or 32-bit boundaries. The separate board address decoder for the CSR allows addresses for hardware control to be grouped for improved software efficiency.

Data Transfer Bus: A16: D8, D16, D32

Built-in-Test: This product supports off-line and real-time fault detection and isolation. The off-line mode is enabled by executing a write to the CSR to set the Test Mode Bit. All outputs are OFF with the Test Mode enabled.

Fail LED: A Fail LED is provided that is illuminated at powerup and extinguished under program control upon successful diagnostic execution.

Output Drivers: This product may be ordered with a variety of output driver options as shown in the Ordering Options. As the Ordering Options show, the board can be manufactured with (1) automatic surge current shutdown protection, (2) no shutdown protection, or (3) thermal shutdown protection for driving incandescent lamps. A detailed description is provided on page 6 for options (1) and (2). The thermal shutdown protection for driving incandescent lamps (3) is described on page 6.

Output Features: The high current driver (600mA sink) outputs are designed to drive incandescent lamps and inductive loads without external current limiting or warming resistors. Due to cold filament inrush currents, it is recommended that only one lamp be driven by the output driver. However, if more than one bulb must be driven by a single wire, then another driver must be connected in parallel. If more than one bulb must be driven by a single output, it is recommended the VMIVME-2131* (current source/sink) or the VMIVME-2130* (current source only) be used if the application will allow. The output drivers of the VMIVME-2131 and VMIVME-2130 will not necessarily support all of the VMIVME-2120* current sink (open collector) applications. In addition to this, the VMIVME-2120 and VMIVME-213x have dissimilar power requirements.

Physical/Environmental Specifications

Dimensions: Double Eurocard

Height	9.2 in. (233.4mm)
Depth	6.3 in. (160mm)

Temperature:

Operating: 0 to +55° C
Storage: -30 to +85° C

Humidity: 20% to 80% relative, noncondensing

Cooling: Forced air convection

Power Requirements:

+5VDC (±5 percent), 0.7A (typical), 1.4A (maximum)

MTBF: Contact factory.

Applications

- Relay drivers
- Triac drivers
- Lamp drivers
- LED drivers
- Solenoid drivers
- High current, high voltage drivers
- Hammer drivers
- Fiber optics LED drivers
- Stepping motor drivers

Positive/Negative True Ordering Information

This board may be ordered with positive or negative true I/O options. The data conversion (inversion) is determined by the selection of data latches which control the output driver transistors.

A positive true output option causes a VMEbus logical one to turn the corresponding output transistor ON, which supplies the user with zero volts.

The negative true output option causes a VMEbus logical one to turn the corresponding output transistor OFF, which supplies the user with an open circuit for open-collector output circuits or with a high for electronic switch type output circuits.

Boards manufactured with the negative true TTL option are designed such that a VMEbus logical one causes the output driver to produce a logic one (high) to the user.

Conversely, the positive true TTL option is designed such that a VMEbus logical one causes the output driver to produce a logic zero (low) to the user.

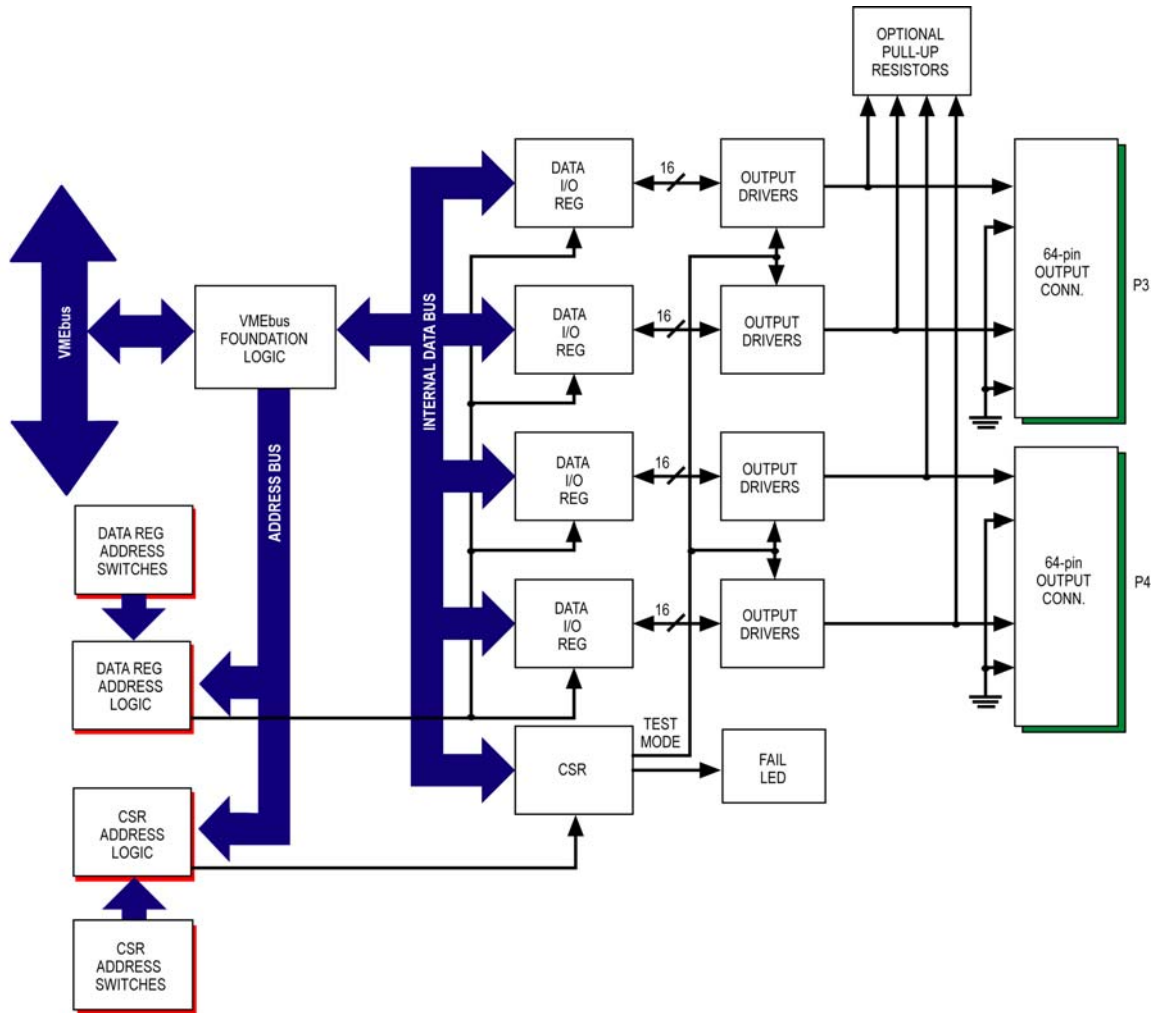
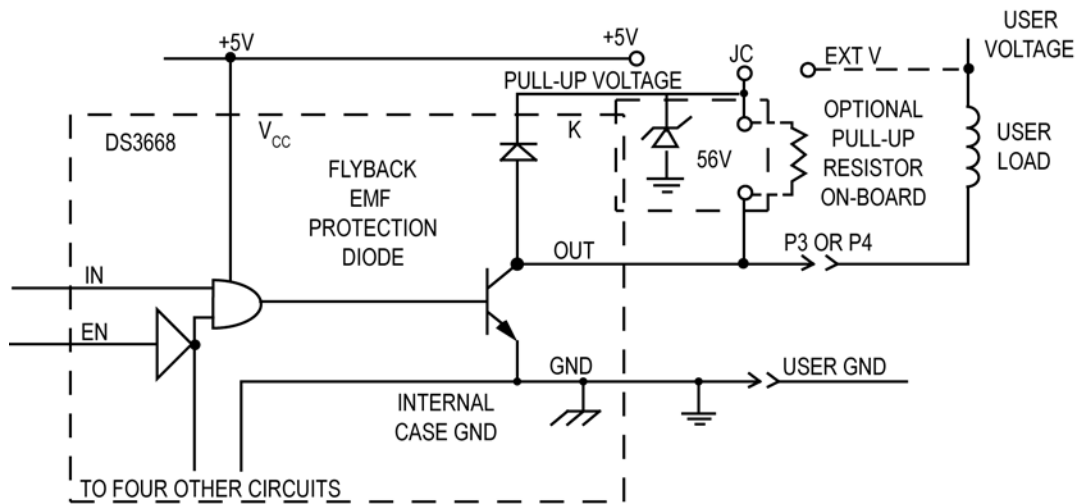

Figure 1. VMIVME-2120 Functional Block Diagram



General Description

The DS3668* quad-peripheral driver is designed for those applications (output options 0 through 2) where low operating power, high breakdown voltage, high output current, and low output ON voltage are required. Unlike most peripheral drivers, a unique fault protection is incorporated on each output. When the load current exceeds 1.0A (approximately) on any output for more than a built-in delay time, nominally 25 ms, that output will be shut off by its protection circuitry with no effect on other outputs. This condition will prevail until that protection circuitry is reset by toggling the corresponding input or the enable pin low for at least 0.5 ms. The 25 ms built-in delay is provided to ensure the protection circuitry is not triggered by turn-on surge currents associated with certain kinds of loads.

The outputs are capable of sinking 600mA each and offer a 55V breakdown. However, for inductive loads, the output should be clamped to 35V or less to avoid latch-up during turn-off (inductive flyback protection). An on-chip clamp diode capable of handling 800mA is provided at each output for this purpose. In addition, the driver incorporates circuitry that guarantees glitch-free power up or down operation and a fail-safe feature which puts the output in high impedance state when the input is open.

Features

- Output fault protection
- High impedance TTL-compatible input
- High output current -600mA per output
- No output latch-up at 35V
- Low output ON voltage (550mV typical at 600mA)
- High breakdown voltage (55V)
- Open-collector outputs
- Output clamp diodes for inductive flyback protection
- NPN inputs for minimal input currents (1mA typical)
- Low operating power
- Standard 5V power supply
- Power up/down protection
- Fail-safe operation
- 2W power package
- Pin-for-pin compatible with SN75437

* A DS3658 quad driver is also available. This device does not support the output fault protection described above. This is used with output options 3 through 5.

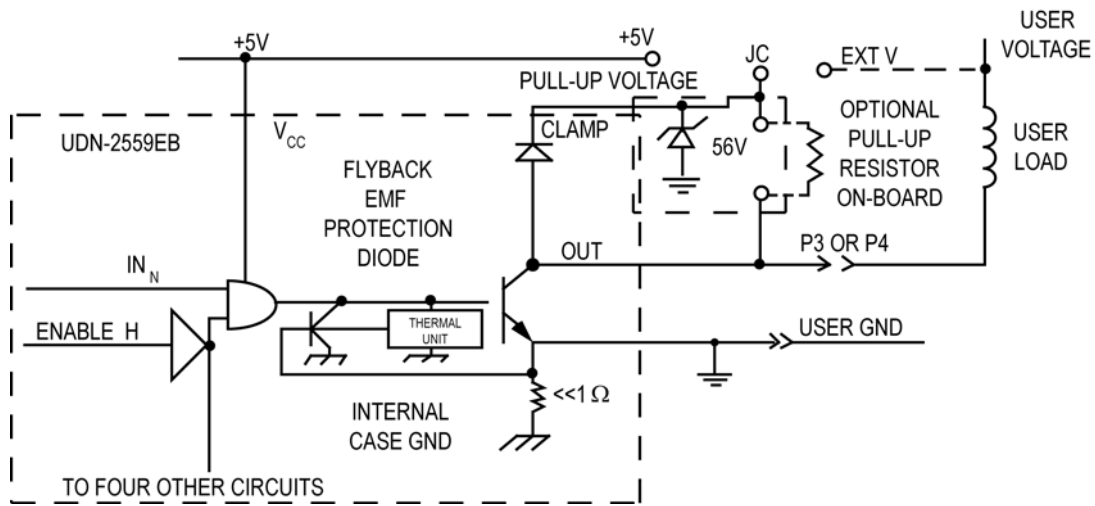

Incandescent Lamp Driver

High incandescent lamp turn-on/inrush current can destroy semiconductor lamp drivers and contributes to poor lamp reliability. However, lamps with steady-state current ratings up to 600mA can be driven with the UDN-2559EB without the need for warming or current limiting resistors (not recommended).

When an incandescent lamp is initially turned ON, the cold lamp filament is at minimum resistance and would normally allow a 10 x to 12 x inrush current. With the UDN-2559EB, during turn-on, the high inrush current is sensed by the internal low-value sense resistor, drive current to the output stage is diverted by the shunting transistor, and the load current is sensed by the internal low-value sense resistor, drive current to the output stage is diverted by the shunting transistor, and the load current is limited to approximately 1A. During this short transition period, the output driver is driven in a linear fashion. During lamp warmup, the filament resistance increases to its maximum value, the output driver goes into saturation and applies full supply voltage to the lamp.

Inductive Load Driver

Bifilar (unipolar) stepper motors can be driven directly. The internal flyback diodes prevent damage to the output transistors by suppressing the high voltage spikes which occur when turning OFF an inductive load.

Fault Conditions

In the event of a shorted load, shorted winding, or stalled motor, the load current will attempt to increase. As described above, the drive current to the output stage is diverted (limiting the load current to about 1A), causing the output stage to go linear. As the junction temperature of the output stage increases, the thermal limit circuit will become operational, further decreasing the drive current. The load current (junction temperature) is then a function of ambient temperature, state of remaining drivers, supply voltage, and load resistance. If the fault condition is corrected, the output driver will return to its normal saturated condition.

Trademarks

* indicates a trademark of GE Intelligent Platforms, Inc. and/or its affiliates. All other trademarks are the property of their respective owners.

VMIVME-2120 64-bit High Voltage Digital Output with Built-in-Test

1. Electronic Switch Option (Open-Collector with Pull-Up Resistor)

Output Voltage	RP Min	IOH Max	IOH	IOL Max	Absolute Max Output Voltage
5V	270 Ω	18.5mA	9.3mA at Vout = 2.5V	600mA	6V
12V	1.5 k Ω	8.0mA	4.0mA at Vout = 6V	600mA	14V
24V	6.8 k Ω	3.5mA	1.8mA at Vout = 12V	600mA	30V
48V	27 k Ω	1.8mA	0.9mA at Vout = 24V	600mA	55V

External Power Supply Requirements

VOEXT MAX Current at RP = MIN

VOEXT	Supply Max	Absolute Max VOEXT
5	1.25A	6V
12	.55A	14V
24	0.25A	30V
48	0.13A	55V

2. TTL Option (Open-Collector with Pull-Up Resistor)

Parameter	Conditions	Min	Max	Unit
VOH	IOH = 400 μ A	4.7V	—	V
VOL	IOH = 4.1mA IOH = 300mA	2.7V	—	V 0.7V

3. Open-Collector Option (No Pull-Up Resistors Installed)

IOL	VOL Typ	VOL Max
300mA	0.20V	0.7V
600mA	0.55V	1.5V



GE Intelligent Platforms Information Centers

Americas:
1 800 322 3616 or 1 256 880 0444

Asia Pacific:
86 10 6561 1561

Europe, Middle East and Africa:
Germany +49 821 5034-0
UK +44 1327 359444

Additional Resources

For more information, please visit the
GE Intelligent Platforms Embedded Systems
web site at:

www.ge-ip.com