

# T1 CSU/DSU ASE

## With DSX-1, Drop-and-Insert, and Modem

### Key features

- Inband management capabilities
- Multi-Protocol or IP Transport software
- Service Level Agreement (SLA) metrics
- Drop-and-Insert capabilities through DSX port
- Internal modem
- Voice over IP (VoIP) analysis capability
- Application analysis capability
- LMI spoofing
- LAN management port
- Power loss detection
- Realtime events

The Visual UpTime® Select™ T1 CSU/DSU ASE is deployed on a T1 access line at the demarcation point between the provider network and customer premises. It supports full and fractional (FT1) T1 networks and provides connectivity through V.35 and additional digital cross connect signal (DSX-1) interfaces.

The ASE supports Multi-Protocol software for deployment in standard frame relay or HDLC networks and IP Transport software for deployment in networks that use IP switching.

The ASE's "drop-and-insert" feature provides a secondary DSX-1 port that can connect to a Private Branch Exchange at a customer's site. T1 Timeslots can be segmented for a PBX on the same circuit carrying data traffic (see figure). The ASE's internal modem lets users establish a telephone connection to either the ASE's administrative interface or a pass-through connection via the serial port.

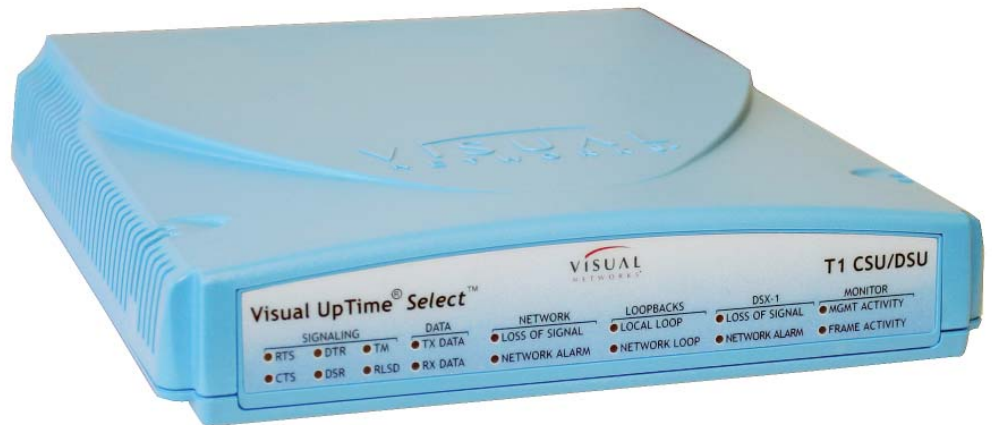

T1 CSU/DSU model 807-0112 front view



T1 CSU/DSU model 807-0112 rear view

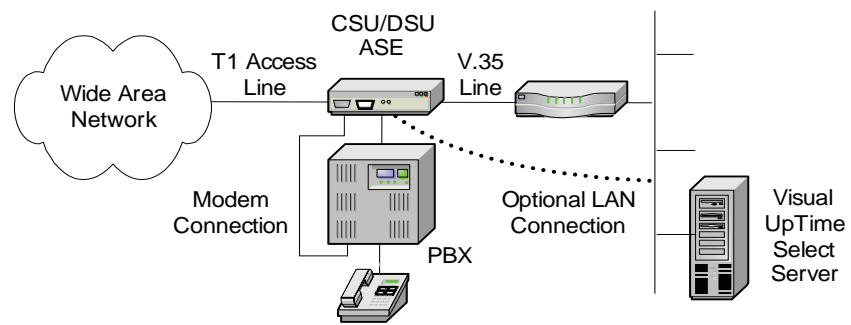

T1 CSU/DSU model 807-0112 position on network



T1 CSU/DSU ASE specifications		
<b>General</b>	Dimensions	8.16" (20.7 cm) x 9.0" (22.8 cm) x 1.62"(4.1 cm) Plastic case with internal power supply.
	Weight	2.10 lbs.
	Data Rate	1.544 Mbps synchronous
	Timing Mode	Derived externally from the T1 network or DSX-1 interface, or internally from the ASE.
<b>Environment</b>	Operating Temperature	0° to +40°C (+32° to +104° F)
	Storage Temperature	-20° to +55°C (-4° to +131° F)
	Clearance Requirement	Minimum of 3" (7.62 cm) space on sides.
	Operating/Storage Humidity	10% to 90%, noncondensing
<b>Power Requirements</b>	Input	100 to 120 VAC
	Frequency	50/60 Hz
	Input Current Rating	0.5 amps
<b>T1 Network Interface</b>	Line Rate	1.544 Mbps ±50 bps synchronous
	Line Format	AMI or B9ZS line coding
	Framing	ESF or D4 framing formats
	ESF FDL	ANSI T1.403, AT&T TR54016, Both, or None
	Input Signal	0dB to -36dB
	Output Signal	0, -7.5dB, -15dB, -22.5dB LBO
	Pulse Density	AT&T 62411
	Connector	8-pin modular jack—USOC: RJ48C
	Timing	Loop, DSX-1, or Internal
	Channel Selection	1 to 24 channels in any combination
	<b>Network DTE Interface (Data Port)</b>	Configuration
Data and Clock Leads		ITU-T V.35
Signaling Leads		EIA RS-232 (ITU-T V.28)
Data Rates		56 kbps x N or 64 kbps x N (N = 1 through 24)
HDLC Inversion		Selectable V.35 data inversion
Transmit Timing Basis		Network selected-source timing
Receive Timing Basis		SCT, inverted SCT, SCTE
Receive Line Data Not Valid		RLSD, CTS
Connector		Female 34-pin V.35 connector
<b>DSX-1 Interface</b>	Line Rate	1.544 Mbps ±50 bps
	Line Format	AMI or B8ZS
	Framing	ESF or D4 (SF)
	Input Signal	-1dB to -11dB
	Line Equalization	0 ft, 133 ft, 266 ft, 399 ft, 533 ft, 655 ft
	Connector	RJ-45
	Channel Selection	1 to 24 channels in any combination
<b>Serial Port Interface</b>	Specifications	19200 or 9600 bps baud rate, 8 data bits no parity, 1 stop bit, EIA RS-232 DTE electrical format, RJ-45 connector
<b>Ethernet 10/100BaseT Interface</b>	Bite Rate	10 or 100 Mbps
	Connector	8-pin modular jack: RJ-48
<b>Modem</b>	Specifications	RJ11 connector, FCC Part 68 and IC-CS03 standards, compliance in US and Canada

## What are ASEs?

ASEs (Analysis Service Elements) are data collection and network performance monitoring hardware devices placed on a wide area network (WAN) or Local Area Network (LAN) as part of the Visual UpTime Select system, which offers in-depth, real-time, and historical visibility into the performance of your applications infrastructure. In the system, data gathered by ASEs is stored in the Visual UpTime Select server and displayed and analyzed from the Visual UpTime Select Web client. As a service level management tool, ASEs indicate when services are being met, provide warnings when services start to degrade, and send alerts when services are not met.

## Hardware Warranties

Enhanced Gold, Bronze, and International Gold ASE hardware warranty service programs are available to help you maximize your investment in Visual UpTime Select. For more detailed warranty information, visit: [www.flukenetworks.com/visualcustomercare](http://www.flukenetworks.com/visualcustomercare)

## Ordering Information

For more details, please contact your Visual UpTime Select authorized reseller or Fluke Networks Sales at (800) 240-4010 or (301) 296-2300.

### NETWORK SUPERVISION

Fluke Networks  
P.O. Box 777, Everett, WA USA 98206-0777

Fluke Networks operates in more than 50 countries worldwide. To find your local office contact details, go to [www.flukenetworks.com/contact](http://www.flukenetworks.com/contact).

©2006 Fluke Corporation. All rights reserved.  
Printed in U.S.A. 2/2006 2643363 D-ENG-N Rev A