

New!



Features

- Ideal radar and software radio interface solution
- Supports Xilinx Virtex-6 LXT and SXT FPGAs
- One-channel mode with 3.6 GHz, 12-bit A/D
- Two-channel mode with 1.8 GHz, 12-bit A/Ds
- 2 GB of DDR3 SDRAM
- Sync bus for multiboard synchronization
- LVDS connections to the Virtex-6 FPGA for custom I/O
- 3U VPX form factor provides a compact, rugged platform
- Compatible with several VITA standards including: VITA-46, VITA-48 and VITA-65 (OpenVPX™ System Specification)
- Ruggedized and conduction-cooled versions available

General Information

Model 53640 is a member of the Cobalt® family of high performance XMC modules based on the Xilinx Virtex-6 FPGA. A high-speed data converter, it is suitable for connection to HF or IF ports of a communications or radar system. Its built-in data capture features offer an ideal turnkey solution as well as a platform for developing and deploying custom FPGA processing IP.

The 53640 includes a 3.6 GHz, 12-bit A/D converter and four banks of memory. It features built-in support for PCI Express over the 3U VPX backplane.

The Cobalt Architecture

The Pentek Cobalt architecture features a Virtex-6 FPGA. All of the board's data and control paths are accessible by the FPGA, enabling factory-installed functions including data multiplexing, channel selection, data packing, gating, triggering and memory control. The Cobalt architecture organizes the FPGA as a container for data processing applications where each function exists as an intellectual property (IP) module.

Each member of the Cobalt family is delivered with factory-installed applications ideally matched to the board's analog interfaces. The 53640 factory-installed functions include an A/D acquisition IP module. In addition, IP modules for DDR3 memories, a controller for all data clocking and synchronization functions, a test signal generator and a PCIe interface complete the factory-

installed functions and enable the 53640 to operate as a complete turnkey solution, without the need to develop any FPGA IP.

Extendable IP Design

For applications that require specialized functions, users can install their own custom IP for data processing. Pentek GateFlow® FPGA Design Kits include all of the factory installed modules as documented source code. Developers can integrate their own IP with the Pentek factory-installed functions or use the GateFlow Design Kit to completely replace the Pentek IP with their own.

Xilinx Virtex-6 FPGA

The Virtex-6 FPGA can be populated with a variety of different FPGAs to match the specific requirements of the processing task. Supported FPGAs include: LX130T, LX240T, LX365T, SX315T, or SX475T. The SXT parts feature up to 2016 DSP48E1 slices and are ideal for modulation/demodulation, encoding/decoding, encryption/decryption, and channelization of the signals between transmission and reception. For applications not requiring large DSP resources, one of the lower-cost LXT FPGAs can be installed.

Option -104 provides 20 pairs of LVDS connections between the FPGA and the VPX P2 connector for custom I/O.

Option -105 provides dual 4X gigabit links between the FPGA and the VPX P1 connector to support serial protocols. ➤

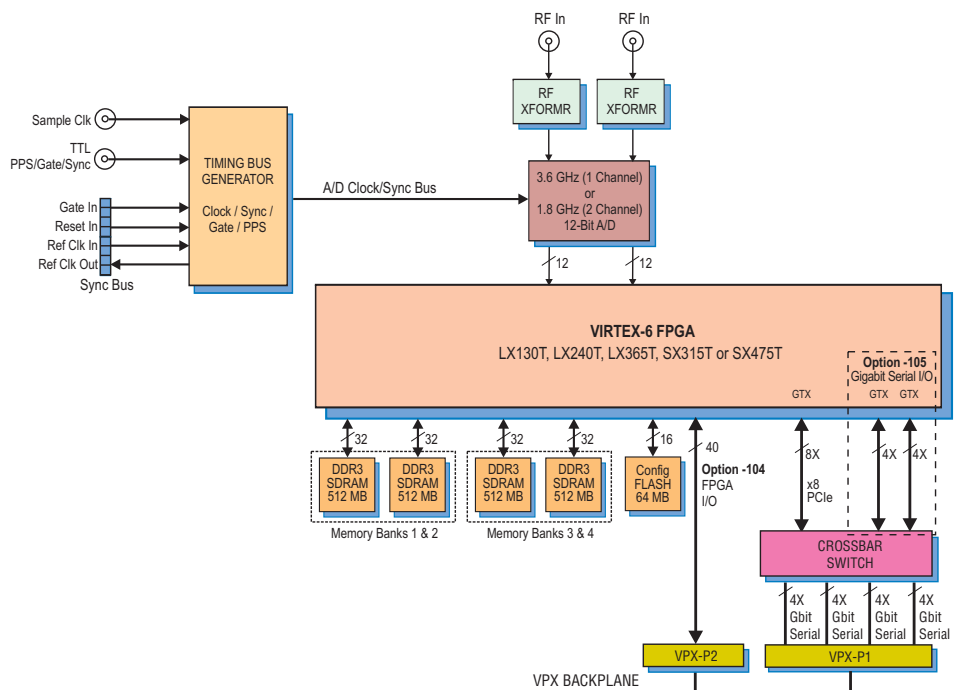

► **A/D Converter Stage**

The front end accepts analog HF or IF inputs on a pair of front panel SSMC connectors with transformer coupling into a National Semiconductor ADC12D1800 12-bit A/D. The converter operates in single-channel interleaved mode with a sampling rate of 3.6 GHz and an input bandwidth of 1.75 GHz; or, in dual-channel mode with a sampling rate of 1.8 GHz and input bandwidth of 2.8 GHz.

The ADC12D1800 provides a programmable 15-bit gain adjustment allowing the 53640 to have a full scale input range of +2 dBm to +4 dBm. A built-in AutoSync feature supports A/D synchronization across multiple boards.

The A/D digital outputs are delivered into the Virtex-6 FPGA for signal processing, data capture or for routing to other module resources.

Clocking and Synchronization

The 53640 accepts a 1.8 GHz dual-edge sample clock via a front panel SSMC connector. A second front panel SSMC accepts a TTL signal that can function as Gate, PPS or Sync.

A front panel multi-pin sync bus connector allows multiple boards to be

synchronized, ideal for larger multichannel systems. The sync bus includes gate, reset and in and out reference clock signals. Multiple 53640s can be synchronized using the Cobalt high speed sync board to drive the sync bus.

Memory Resources

The 53640 architecture supports four independent memory banks of DDR3 SDRAM. Each bank is 512 MB deep and is an integral part of the board's DMA and data capture capabilities. Built-in memory functions include an A/D data transient capture mode for taking snapshots of data for transfer to a host computer.

In addition to the factory-installed functions, custom user-installed IP within the FPGA can take advantage of the memories for many other purposes.

PCI Express Interface

The Model 53640 includes an industry standard interface fully compliant with PCI Express Gen. 1 & 2 bus specifications. Supporting PCIe links of x4 or x8, the interface includes multiple DMA controllers for efficient transfers to and from the board. ►

A/D Acquisition IP Module

The 53640 features an A/D Acquisition IP Module for easy capture and data moving. The IP module can receive data from the A/D, or a test signal generator. The IP module has associated memory banks for buffering data in FIFO mode or for storing data in transient capture mode. In single-channel mode, all four banks are used to store the single-channel of input data. In dual-channel mode, memory banks 1 and 2 store data from input channel 1 and memory banks 3 and 4 store data from input channel 2. In both modes, continuous, full-rate transient capture of 12-bit data is supported.

The memory banks are supported with a DMA engine for moving A/D data through the PCIe interface. This powerful linked-list DMA engine is capable of a unique Acquisition Gate Driven mode. In this mode, the length of a transfer performed by a link definition need not be known prior to data acquisition; rather, it is governed by the length of the acquisition gate. This is extremely useful in applications where an external gate drives acquisition and the exact length of that gate is not known or is likely to vary.

For each transfer, the DMA engine can automatically construct metadata packets containing a sample-accurate time stamp, and data length information. These actions simplify the host processor's job of identifying and executing on the data.

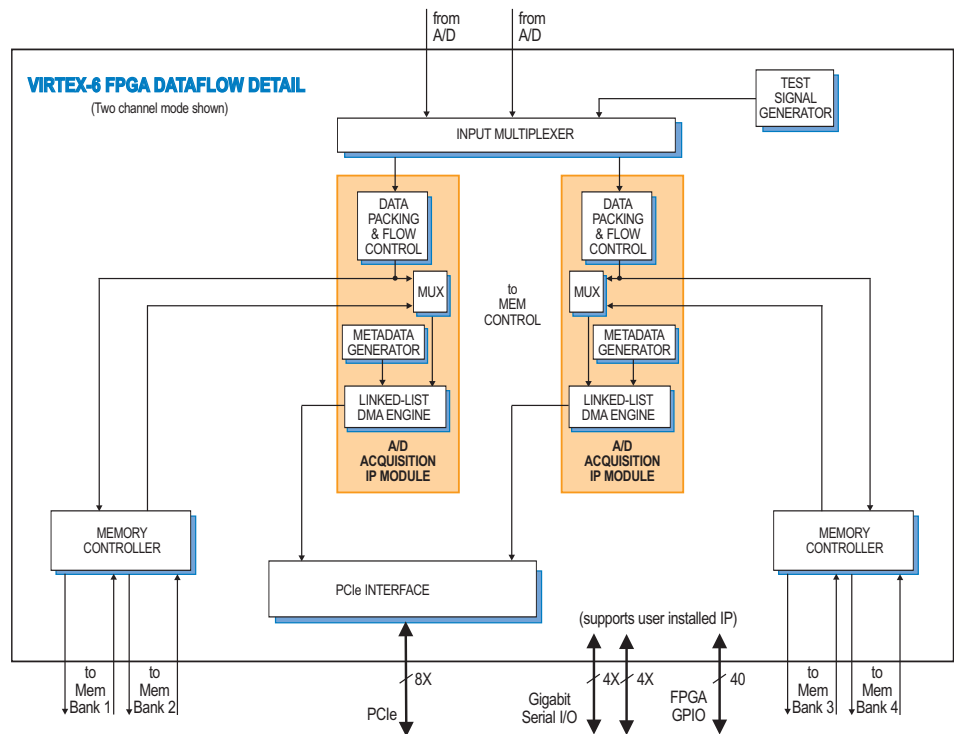

► Fabric-Transparent Crossbar Switch

The 53640 features a unique high-speed switching configuration. A fabric-transparent crossbar switch bridges numerous interfaces and components on the board using gigabit serial data paths with no latency.

Programmable signal input equalization and output pre-emphasis settings enable optimization. Data paths can be selected as single (1X) lanes, or groups of four lanes (4X).

Specifications

Front Panel Analog Signal Inputs

Input Type: Transformer-coupled, front panel female SSMC connectors

A/D Converter

Type: National Semiconductor ADC12D1800

Sampling Rate: Single-channel mode: 500 MHz to 3.6 GHz; dual-channel mode: 150 MHz to 1.8 GHz

Resolution: 12 bits

Input Bandwidth: single-channel mode: 1.75 GHz; dual-channel mode: 2.8 GHz

Full Scale Input: +2 dBm to +4 dBm, programmable

Sample Clock Sources: Front panel SSMC connector

Sync Bus: Multi-pin connectors, bus includes gate, reset and in and out ref clock

External Trigger Input

Type: Front panel female SSMC connector, TTL

Function: Programmable functions include: trigger, gate, sync and PPS

Field Programmable Gate Array

Standard: Xilinx Virtex-6 XC6VLX130T-2

Optional: Xilinx Virtex-6 XC6VLX240T-2, XC6VLX365T-2, XC6V SX315T-2, or XC6V SX475T-2

Custom I/O

Option -104: Provides 20 pairs of LVDS connections between the FPGA and the VPX P2 connector for custom I/O

Option -105: Provides one 8X or two 4X gigabit links between the FPGA and the VPX P1 connector to support serial protocols

Memory: Four 512 MB DDR3 SDRAM memory banks, 400 MHz DDR

PCI-Express Interface

PCI Express Bus: Gen. 1 or Gen. 2: x4 or x8

Environmental

Operating Temp: 0° to 50° C

Storage Temp: -20° to 90° C

Relative Humidity: 0 to 95%, non-cond.

Size: 3.937 in. x 6.717 in. (100 mm x 170.6 mm).

Ordering Information

Model Description

53640 1-Ch. 3.6 GHz or 2-Ch. 1.8 GHz, 12-bit A/D, Virtex-6 FPGA - 3U VPX

Options:

-002* -2 FPGA speed grade
 -062 XC6VLX240T
 -063 XC6VLX365T
 -064 XC6V SX315T
 -065 XC6V SX475T
 -104 LVDS FPGA I/O to VPX P2
 -105 Gigabit serial FPGA I/O to VPX P1
 -155* Two 512 MB DDR3 SDRAM Memory Banks (Banks 1 and 2)
 -165* Two 512 MB DDR3 SDRAM Memory Banks (Banks 3 and 4)

* these options always included

Contact Pentek for availability of rugged and conduction-cooled versions