

# A simple single-phase DC drive in a NEMA 4 enclosure for 1/4-5 HP regenerative or non-regenerative applications



**With MinPak Plus drives you get the standard features you need and the options and modification kits to meet your specific application requirements now or in the future. What's more, you get them from stock.**

MinPak Plus drives feature proven electronic components, which significantly improve drive functions, reliability and overall performance. These include custom Large Scale Integrated (LSI) circuits and a modular power cube that is doubly protected by a circuit breaker and MOV surge suppressor. A relay prevents uncontrolled restarts after power outages.

A variety of modification kits allow you to tailor these drives to your specific application requirements. They can be installed quickly by your Reliance Electric authorized distributor, your own personnel or at the factory.

## STANDARD FEATURES

- Compact, protected enclosure is standard
- UL certified NEMA 4/12 drive design keeps out dust, oil and liquids for maximum drive reliability
- FDA approved enclosure
- Application versatility with optional, plug-in kits
- Easy installation and service
- 50/60 Hz for worldwide application
- Enclosures can be wall mounted vertically or horizontally for installation flexibility
- Fully regenerative, four-quadrant models provide contactorless reversing as well as hold-back torque capability
- Drive is easily convertible to chassis mount for fast, space-saving installation in other equipment or cabinets

- PowerMatched with Reliance Electric DC motors for optimum performance
- Field supply for motor shunt field (2-5 HP)
- Adjustable minimum and maximum speed, acceleration rate, deceleration rate, current limit and IR compensation
- Full-wave, full-control conversion for smooth, efficient operation and high performance
- Power semi-conductors are contained in easily replaceable power cubes to speed service and maintenance
- Built-in surge suppressor protects semi-conductors from line transients for higher reliability
- Circuit breaker eliminates fuse replacement for reduced service and maintenance requirements
- Relay in control circuit prevents automatic restarting after power outage
- Isolated voltage and current feedbacks for improved drive reliability and versatility
- Current limit control protects the drive and driven machine from damaging current or torque levels for improved reliability
- Motor armature contactor disconnects power to the drive motor
- Armature loop DC circuit breaker protects equipment against inverting faults (regenerative drives only)

## AVAILABLE OPTIONS

- Remote Operator Adapter Kit for buffering and filtering of external signals when drive is operated by remote control.
- Dynamic Braking Kit
- Reversing Contactor Kit (Non-regenerative drives)
- Automatic Reversing Kit (Non-regenerative drives only)
- Double Pole Circuit Breaker Kit allows removal of all voltages from control circuits (Standard on regenerative drives)

## MORE OPTIONS

- Tachometer Feedback Kit allows speed regulation to 0.5% with 95% load change with specified tachometer (Standard on regenerative drives)
- Voltage Follower Kit allows the drive to follow an external DC voltage signal
- Instrument Interface/Preset Speed Kit for applications where drive speed is controlled by a process controller over a speed range, or when an adjustable preset speed is desired
- Field Supply Kit for applications requiring the use of a wound field DC motor (Standard on 2 through 5 HP drives)
- Test Meter Adapter Kit for measuring drive and regulator signal voltages with a voltmeter
- Auxiliary Contact Kit
- Torque Taper Kit for winder applications (Non-regenerative drives only)
- Variety of local or remote operation stations available

## ENGINEERING DATA

### Service Conditions

- Elevation: Up to 3300 feet (1000 meters)
- Ambient Temperatures:
  - Enclosed Models: 32° F to 104° F (0° C to 40° C)
  - Chassis Models: 32° F to 131° F (0° C to 55° C)
- Atmosphere: Non-condensing relative humidity 5% to 95%
- AC Line Voltage Variation: +10% of rated voltage
- AC Frequency: 48 to 62 Hz

### Application Data

- Service Factor: 1.0
- Maximum Load: 150% for 1 minute
- Speed Regulation (95% load change):
- Voltage Feedback: 1-2%
- Tachometer Feedback: 1% or 0.5% \*
- Speed Range
- Voltage Feedback: 20:1
- Tachometer Feedback: 30:1

### Adjustments

- Maximum Speed (Percent of rated): 50 to 100%
- Minimum Speed (Percent of rated): 10 to 50%
- Current Limit (Percent of rated): 10 to 150%
- IR Drop Compensation: 0 to 12%
- Acceleration Rate: 0.5 to 30 seconds linear
- Deceleration Rate: 0.5 to 30 seconds linear

\*Depending on tachometer used.

### Drive Ratings

| Motor HP | 115 VAC Input                       |           |                     |                               |  |   |
|----------|-------------------------------------|-----------|---------------------|-------------------------------|--|---|
|          | 230 VAC Input                       |           |                     |                               |  |   |
|          | Rated AC Line (Amps) <sup>(1)</sup> | Input KVA | DC Armature Voltage | Rated Armature Current (Amps) | Available Field Voltage <sup>(2)</sup> | Available Field Current (Amps) <sup>(2)</sup> |
| 1/4      | 3.5                                 | 0.4       | 90                  | 2.5                           | 100                                    | 3   |
|          | -                                   | -         | -                   | -                             | -                                      | -   |
| 1/3      | 5.2                                 | 0.6       | 90                  | 3.7                           | 100                                    | 3   |
|          | -                                   | -         | -                   | -                             | -                                      | -   |
| 1/2      | 7                                   | 0.81      | 90                  | 5                             | 100                                    | 3   |
|          | 3.5                                 | 0.81      | 180                 | 2.5                           | 200                                    | 3   |
| 3/4      | 10.5                                | 1.2       | 90                  | 7.5                           | 100                                    | 3   |
|          | 5.2                                 | 1.2       | 180                 | 3.7                           | 200                                    | 3   |
| 1        | -                                   | -         | -                   | -                             | -                                      | -   |
|          | 7                                   | 1.61      | 180                 | 5                             | 200                                    | 3   |
| 1-1/2    | -                                   | -         | -                   | -                             | -                                      | -   |
|          | 10.5                                | 2.42      | 180                 | 7.5                           | 200                                    | 3   |
| 2        | -                                   | -         | -                   | -                             | -                                      | -   |
|          | 14                                  | 3.22      | 180                 | 10                            | 200                                    | 3   |
| 3        | -                                   | -         | -                   | -                             | -                                      | -   |
|          | 21                                  | 4.83      | 180                 | 15                            | 200                                    | 3   |
| 5        | -                                   | -         | -                   | -                             | -                                      | -   |
|          | 35                                  | 8.05      | 180                 | 25                            | 200                                    | 3   |

(1) Includes Motor Field Current

(2) Stated with optional Field Supply Kit. Standard on 2, 3 and 5 HP models

## SINGLE-PHASE MINPAK PLUS DRIVES

Ordering instructions for NEMA 4/12 enclosed drives

1. Select model number and price drives from selection chart below.
2. Select operator controls as follows:
  - For local controls select M/N 14C201-14C208 from page D-143 and add **\$145 x VS-3DC** discount if supplied loose or **\$220 x VS-3DC** installed.
  - For remote controls specify M/N 14C220 (remote adapter kit) and M/N 14C200 lank panel) and add **\$155 x VS-3DC** discount if supplied loose, or **\$235 x VS-3DC** mounted.
  - For model number and price selection of remote operator stations see page D-185.
3. Select and price additional kit options from pages D-141 through D-145.



### Drive Selection Chart

| HP          | Drive Rating     |                   |          | Non-regenerative Drive |              |            |              | Regenerative Drive |                |            |              |
|-------------|------------------|-------------------|----------|------------------------|--------------|------------|--------------|--------------------|----------------|------------|--------------|
|             | AC Input (Volts) | DC Output (Volts) |          | Cabinet                |              | Chassis(2) |              | Cabinet            |                | Chassis(2) |              |
|             |                  | 50/60 Hz          | Armature | Field                  | Model Number | List       | Model Number | List               | Model Number   | List       | Model Number |
| 1/4-3/4     | 115              | 90                | (1)      | * 14C10                | <b>\$850</b> | * 14C20    | (2)          | * 14C30            | <b>\$1,410</b> | 14C40      | (2)          |
| 1/2 - 1-1/2 | 230              | 180               | (1)      | * 14C11                | <b>875</b>   | * 14C21    | (2)          | * 14C31            | <b>1,410</b>   | 14C41      | (2)          |
| 2-3         | 230              | 180               | 100/200  | * 14C12                | <b>900</b>   | * 14C22    | (2)          | * 14C32            | <b>1,575</b>   | 14C42      | (2)          |
| 5           | 230              | 180               | 100/200  | * 14C13                | <b>1,350</b> | * 14C23    | (2)          | * 14C33            | <b>1,790</b>   | 14C43      | (2)          |

(1) If a wound field motor is used with the drive also order field supply kit 14C228 for Non-regenerative or 14C238 for Regenerative MinPak Plus, add \$65 (unmounted) or \$140 (mounted) x VS-3DC discount. Provides 50 or 100 VDC for 115 VAC input drives and 100 or 200 VDC for 230 VAC input drives.

(2) Chassis models are discontinued. Specify cabinet model and a remote adapter kit (Model 14C220) and remove enclosure cover to convert to chassis drive.

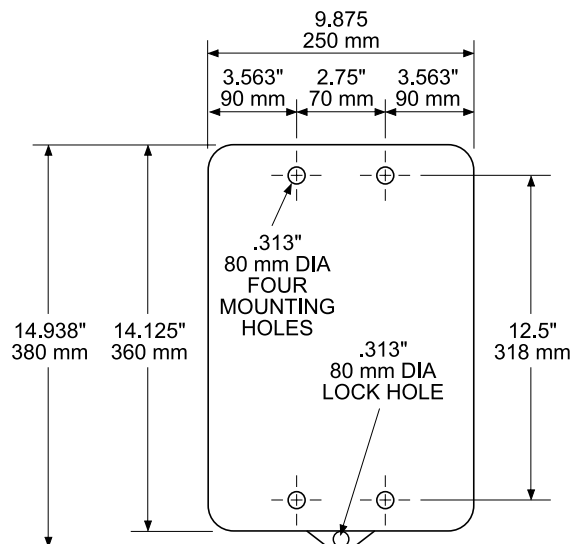

\* Normally carried in stock

# A versatile, reliable single-phase chassis DC drive for non-regenerative (1/4-5 HP) and regenerative (1/4 - 7-1/2 HP) applications

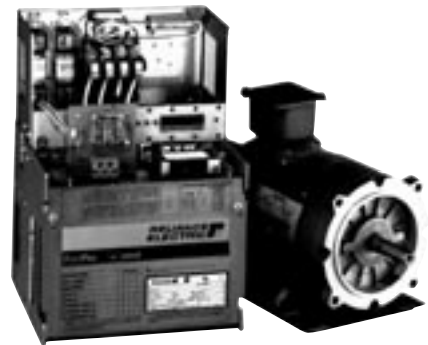

With FlexPak Plus DC drives you get the standard features you need and the options and modification kits to meet your specific application variables.

FlexPak Plus Drives feature proven electronic components, which significantly improve drive functions, reliability and overall performance. These include custom Large Scale Integrated (LSI) circuits and a modular Power Cube that's doubly protected by AC line fuses and a MOV surge suppressor. A relay prevents uncontrolled restarts after power outages.

FlexPak Plus drives are available immediately from the largest stock of adjustable speed drives in the industry. A variety of modification kits to tailor these drives to your specific application requirements can be installed quickly by your Reliance Electric Authorized Distributor, or your own personnel or at the factory.

## STANDARD FEATURES

- Compact, open-chassis design
- Application versatility with optional kit selection. Kits plug into controller quickly and easily.
- Easy installation and service
- 50/60 Hz for worldwide application
- Full-wave, full-control conversion for smooth, efficient operation and high performance
- Isolated voltage and current feedbacks for drive reliability and versatility
- Fully regenerative, four-quadrant models provide contactorless reversing as well as hold-back torque capability through 7-1/2 HP
- PowerMatched with Reliance Electric DC motors for optimum performance
- Field supply for motor shunt field (2 - 7-1/2 HP)
- Minimum and maximum speed, acceleration rate, deceleration rate, current limit and IR compensation are easily adjustable for increased application flexibility

- Power semi-conductors are contained in easily replaceable power cubes to speed service and maintenance
- Built-in surge suppressor helps protect semi-conductors from line transients for higher reliability
- Relay in control circuit prevents automatic restarting after power outage
- Current limit control protects the drive and driven machine from damaging current or torque levels for improved reliability
- Motor armature contactor disconnects power to the drive motor
- Armature loop DC circuit breaker protects equipment against inverting faults (regenerative controllers only)
- Auxiliary panel provides fused AC line protection and motor armature contactor to disconnect power to the drive motor
- Remote Operator Adapter Kit for buffering and filtering of external signals when drive is operated by remote control

## AVAILABLE OPTIONS

- Dynamic Braking Kit
- Tachometer Feedback Kit allows speed regulation to 0.5% with 95% load change with specified tachometer. (Standard on regenerative drives)
- Reversing Contactor Kit (Non-regenerative drives)
- Automatic Reversing Kit (Non-regenerative controllers only)
- Voltage Follower Kit allows the drive to follow an external DC voltage signal
- Instrument Interface/Preset Speed Kit for applications where drive speed is controlled by a process controller over a speed range, or when an adjustable preset speed is desired

## MORE OPTIONS

- Field Supply Kit for applications requiring the use of a wound field DC motor. (Standard on 2-7.5 HP drives)
- Test Meter Adapter Kit for measuring drive and regulator signal voltages with a voltmeter.
- Auxiliary Contact Kit
- Torque Taper Kit for winder applications. (Non-regenerative drives only)
- Separate NEMA rated types 1, 3R, 4, 4X and 12 operator control stations available for remote operation of the drive (Refer to page D-169 for selection and pricing information).

## ENGINEERING DATA

### Drive Ratings

| Motor HP | 115 VAC Input                  |           |                        |                                     |                                   |  |
|----------|--------------------------------|-----------|------------------------|-------------------------------------|-----------------------------------|--|
|          | 230 VAC Input                  |           |                        |                                     |                                   |  |
|          | Rated AC Line<br>(Amps)<br>(1) | Input KVA | DC Armature<br>Voltage | Rated Armature<br>Current<br>(Amps) | Available Field<br>Voltage<br>(2) | Available Field<br>Current (Amps)<br>(2) |
| 1/4      | 3.5                            | 0.4       | 90                     | 2.5                                 | 100                               | 3  |
|          | -                              | -         | -                      | -                                   | -                                 | -  |
| 1/3      | 5.2                            | 0.6       | 90                     | 3.7                                 | 100                               | 3  |
|          | -                              | -         | -                      | -                                   | -                                 | -  |
| 1/2      | 7                              | 0.81      | 90                     | 5                                   | 100                               | 3  |
|          | 3.5                            | 0.81      | 180                    | 2.5                                 | 200                               | 3  |
| 3/4      | 10.5                           | 1.2       | 90                     | 7.5                                 | 100                               | 3  |
|          | 5.2                            | 1.2       | 180                    | 3.7                                 | 200                               | 3  |
| 1        | -                              | -         | -                      | -                                   | -                                 | -  |
|          | 7                              | 1.61      | 180                    | 5                                   | 200                               | 3  |
| 1.5      | -                              | -         | -                      | -                                   | -                                 | -  |
|          | 10.5                           | 2.42      | 180                    | 7.5                                 | 200                               | 3  |
| 2        | -                              | -         | -                      | -                                   | -                                 | -  |
|          | 14                             | 3.22      | 180                    | 10                                  | 200                               | 3  |
| 3        | -                              | -         | -                      | -                                   | -                                 | -  |
|          | 21                             | 4.83      | 180                    | 15                                  | 200                               | 3  |
| 5        | -                              | -         | -                      | -                                   | -                                 | -  |
|          | 35                             | 8.05      | 180                    | 25                                  | 200                               | 3  |
| 7.5      | -                              | -         | -                      | -                                   | -                                 | -  |
|          | 48                             | 11.04     | 180                    | 36                                  | 200                               | 3  |

(1) Includes Motor Field Current

(2) Stated with optional Field Supply Kit

Standard on 2 - 7-1/2 HP models

### Service Conditions

- Elevation: Up to 3300 feet(1000 meters)
- Ambient Temperatures: 32°F to 131°F (0°C to 55°C)
- Atmosphere: Non-condensing relative humidity 5% to 95%
- AC Line Voltage Variation: +10% of rated voltage
- AC Frequency: 48 to 62 Hz

### Application Data

- Service Factor: 1.0
- Maximum Load: 150% for 1 minute
- Speed Regulation (95% load change):  
Voltage Feedback: 1-2%
- Tachometer Feedback: 1% or 0.5%\*
- Speed Range
- Voltage Feedback: 20:1
- Tachometer Feedback: 30:1

## ADJUSTMENTS

- Maximum Speed (Percent of rated):  
50 to 100%
- Minimum Speed (Percent of rated):  
10 to 50%
- Current Limit (Percent of rated):  
10 to 150%
- IR Drop Compensation: 0 to 12%
- Acceleration Rate:  
0.5 to 30 seconds linear
- Deceleration Rate:  
0.5 to 30 seconds linear

\*Depending on tachometer used

# SINGLE-PHASE FLEXPAC PLUS DRIVES

## Ordering instructions for chassis drives

1. Select model number and price drive from selection chart below.
2. Select model number and price remote operator controls from page D-185.
3. Select and price kit options from pages D-152 through D-158.



## Drive Selection Chart

| HP          | AC Input (volts)<br>50/60 Hz | Drive Rating      |         | Non-regenerative Drive <sup>(2)</sup> |       | Regenerative Drive <sup>(2)</sup> |         |
|-------------|------------------------------|-------------------|---------|---------------------------------------|-------|-----------------------------------|---------|
|             |                              | DC Output (Volts) |         | Chassis with Auxiliary Panel          |       | Chassis with Auxiliary Panel      |         |
|             |                              | Armature          | Field   | Model Number                          | List  | Model Number                      | List    |
| 1/4-3/4     | 115                          | 90                | (1)     | * 14C101                              | \$990 | * 14C106                          | \$1,415 |
| 1/2 - 1-1/2 | 230                          | 180               | (1)     | * 14C102                              | 995   | * 14C107                          | 1,415   |
| 2-3         | 230                          | 180               | 100/200 | * 14C103                              | 1025  | * 14C108                          | 1,635   |
| 5           | 230                          | 180               | 100/200 | * 14C104                              | 1,435 | * 14C109                          | 1,695   |
| 7-1/2       | 230                          | 180               | 100/200 | -                                     | -     | * 14C111                          | 2,535   |

(1) If a wound field motor is used also order field supply kit 14C237 and add \$65 List (unmounted) or \$140 List (mounted).

(2) Includes a model 14C220 remote operator adapter kit, installed.

## DIMENSIONS

NON-REGENERATIVE DRIVE

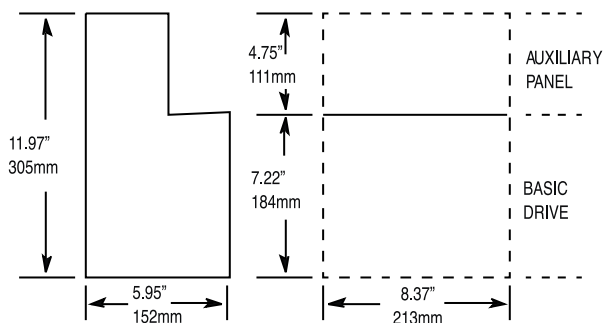

REGENERATIVE DRIVE

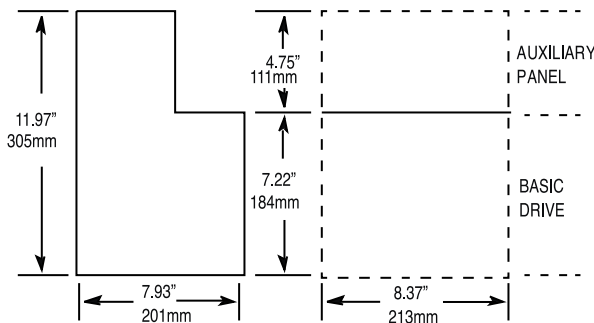

\* Normally carried in stock

## MinPak Plus PRODUCT PUBLICATIONS

### Non-Regenerative Drives

Data Sheet, 1/4-5 HP, 1-Phase: D-2625  
 Instruction Manual containing wiring diagrams and dimensions for drive and kits, 1/4-5 HP, 1-Phase: D-3838

### Regenerative Drives

Data Sheet: D-2625  
 Instruction manual containing wiring diagrams and dimensions for controller and kits: D-3899

## FlexPak Plus PRODUCT PUBLICATIONS

### Non-Regenerative Drives

Data Sheet, Single-Phase: D-2652  
 Instruction Manual containing wiring diagrams and dimensions for drive and kits, 1/4-5 HP, Single-Phase: D-3900

### Regenerative Drives

Data Sheet: D-2652  
 Instruction manual containing wiring diagrams and dimensions for drive and kits: D-3901

## INSTRUCTION MANUALS FOR KITS

| Kit Name                    | Model Number  | I/M     | Single-Phase          |                        |                   |                    |
|-----------------------------|---------------|---------|-----------------------|------------------------|-------------------|--------------------|
|                             |               |         | MinPak Plus Non-Regen | FlexPak Plus Non-Regen | MinPak Plus Regen | FlexPak Plus Regen |
| Auxiliary "M" Contact       | 14C219        | D2-3383 | √                     | √                      | √                 | √                  |
| Dancer Follower Kit         | 14C230        | D-3966  | √                     | √                      | √                 | √                  |
| Dynamic Braking             | 14C214-14C216 | D2-3378 | √                     | √                      | √                 | √                  |
| Field Supply Kit            | 14C228        | D2-3380 | √                     |                        |                   |                    |
| Field Supply Kit            | 14C238        | D2-3381 |                       |                        | √                 |                    |
| Field Supply Kit            | 14C237        | D2-3382 |                       | √                      |                   | √                  |
| Inst. Interface Kit         | 14C222        | D-3967  | √                     | √                      | √                 | √                  |
| Remote Operator Adapter Kit | 14C220        | D-3979  | √                     |                        | √                 |                    |
| Test Meter Adapter Kit      | 14C225        | D-3970  | √                     | √                      | √                 | √                  |
| Voltage Follower Kit        | 14C223        | D-3971  | √                     | √                      | √                 | √                  |
| Automatic Reversing Kit     | 14C226        | D2-3384 | √                     | √                      |                   |                    |
| Double Pole Disconnect      | 14C210-14C213 | D2-3385 | √                     |                        |                   |                    |
| Reversing Contactor Kit     | 14C217-14C218 | D2-3377 | √                     |                        |                   |                    |
| Reversing Contactor Kit     | 14C293        | D2-3293 |                       | √                      |                   |                    |
| Tach Feedback Kit           | 14C221        | D-3969  | √                     | √                      |                   |                    |
| Torque Taper Kit            | 14C224        | D2-3386 | √                     | √                      |                   |                    |
| Local Operator Control      | 14C200-14C208 | D-3977  | √                     |                        | √                 |                    |
| Accessory Mounting Bracket  | 14C209        | D2-3379 | √                     |                        |                   |                    |

## MODIFICATION KITS FOR NON-REGENERATIVE AND REGENERATIVE DRIVES

The following modification kits are easily installed inside MinPak Plus or FlexPak Plus drives, either in a cabinet or a chassis configuration. It is essential that the operator's control selected offer the same features as the modification kit used.

| Description                                  | Page         | HP, Phase               | MinPak Plus              | FlexPak Plus     |
|--|--------------|-------------------------|--------------------------|------------------|
|  |              |                         | Kit Model <sup>(1)</sup> |                  |
| Auxiliary M Contact Kit                      | on this page | 1/4-5, 1-Phase          | 14C219                   | 14C219           |
| Auxiliary Mounting Bracket                   | on this page | 1/4-5, 1-Phase          | 14C209                   | N/A              |
| Dancer Follower Kit                          | on this page | All                     | 14C230                   | 14C230           |
| Dynamic Braking (DB) Kit                     | on this page | 1/4-5, 1-Phase          | 14C214-<br>14C216        | 14C214<br>14C216 |
| Field Supply Kit                             | on this page | 1/4 - 1-1/2,<br>1-Phase | 14C228<br>14C238         | 14C237           |
| Instrument Interface/<br>Preset Speed Kit    | D-143        | All                     | 14C222                   | 14C222           |
| Local Operator Control<br>Stations           | D-143        | All                     | 14C201-<br>14C208        | N/A              |
| Remote Operator Adapter Kit                  | D-143        | All                     | 14C220                   | Std.             |
| Test Meter Adapter Kit                       | D-143        | All                     | 14C225                   | 14C225           |
| Voltage/Tachometer-Generator<br>Follower Kit | D-143        | All                     | 14C223                   | 14C223           |

(1) Three-phase kits have been discontinued.

**AUXILIARY M CONTACT KIT** provides a contact which indicates the state of the M contactor - either open or closed. This kit contains a form C contact [1-N.O. (normally open) and 1-N.C. (normally closed) with a common terminal].

Auxiliary M Contact Kit for all 1/4-7.5 HP single-phase MinPak Plus/FlexPak Plus drives. If this kit is installed in a 1/4-.75 HP Model 14C10/14C20 or 1/2-1.5 HP Model 14C11/14C21 MinPak Plus, it will also be necessary to order Auxiliary Mounting Bracket Model 14C209.

**Kit Model \* 14C219 . . . . . \$80 List**  
**Factory Installed: . . . . . \$155 List**

**AUXILIARY MOUNTING BRACKET** provides a convenient means to mount one or two kits on 1/4 - 1-1/2 HP MinPak Plus drives (14C10 and 14C11) and (14C20 and 14C21): Auxiliary M Contact Kit (14C219) and Automatic Reversing Kit (14C226). This kit is supplied as standard in 2-5 HP single-phase controllers. (Models 14C12 and 14C13).

**Kit Model \* 14C209 . . . . . \$40 List**  
**Factory Installed . . . . . \$115 List**

**DANCER FOLLOWER KIT** allows the MinPak Plus/FlexPak Plus drive to be controlled automatically in response to a speed reference generated by a line speed signal and trimmed by a dancer potentiometer. The kit will accept a line speed input signal of 0-4 VDC to 0-10 VDC to obtain maximum speed. The input impedance is approximately 25k ohms. The dancer potentiometer should be 5k ohms and the optional dancer position potentiometer should be 25k ohms. The dancer potentiometer and the dancer position potentiometer are not included in this kit. Applications include web or strip process lines where a drive must closely follow or maintain the position of a dancer and where the system has 3 seconds or more of storage.

**Kit Model \* 14C230 . . . . . \$145 List**  
**Factory Installed . . . . . \$220 List**

**DYNAMIC BRAKING (DB) KIT** reduces the stopping time of the motor when the STOP button is depressed. Under normal operation, the motor will coast-to-rest. If a Dynamic Braking Kit has been added, when the STOP button is depressed, the motor operates as a generator, and the rotating mechanical energy is turned into electrical energy which is dissipated as heat in the dynamic braking resistor.

**NOTE:** Dynamic braking is not a holding brake, and will not keep a motor from turning. See selection chart below. Mounts on top of MinPak Plus and separate mount for FlexPak Plus.

| Drive Rating                       | MinPak Plus & FlexPak Plus         |          |                        |
|------------------------------------|------------------------------------|----------|------------------------|
|                                    | Dynamic Braking Kit <sup>(1)</sup> |          |                        |
|                                    | Model                              | Kit List | Factory Installed List |
| 1/4-.5 HP @ 115 VAC, 1-Phase       | * 14C214                           | \$43     | \$118                  |
| 2-3 HP @ 230 VAC, 1-Phase          |                                    |          |                        |
| 3/4 HP @ 115 VAC, 1-Phase          | * 14C215                           | 43       | 118                    |
| 1/2, 1-1/2 HP @ 230 VAC<br>1-Phase | * 14C216                           | 43       | 118                    |
| 5 HP @ 230 VAC, 1-Phase            |                                    |          |                        |

(1) Three-phase kits have been discontinued.

**FIELD SUPPLY KIT** provides full-wave field excitation for shunt-wound DC motors. It may be optionally added to drives 1/4 through 1-1/2 HP. (An appropriate field supply is standard for 2 through 40 HP MinPak Plus/FlexPak Plus drives.) The kit has a 3 amp capacity and supplies 50 or 100 VDC when installed in the 115 V drives. When installed in 230 V drives, the kit supplies 100 or 200 VDC.

**Kit Model \* 14C228 Non-Regen. MinPak Plus . . . . . \$65 List**  
**Kit Model \* 14C238 Regen. MinPak Plus . . . . . \$65 List**  
**Kit Model \* 14C237 All FlexPak Plus . . . . . \$65 List**  
**Factory Installed . . . . . \$140 List**

\* Normally carried in stock



**INSTRUMENT INTERFACE/PRESET SPEED KIT** enables a MinPak Plus/FlexPak Plus to operate in one of two modes: (1) Automatically follow a milliamp signal from a process controller. (2) Operate at an internally adjusted preset speed or at the speed set by the main speed setting potentiometer. As a process control follower, the kit will accept a 0-5, 1-5, 4-20, or 10-50 mA, grounded or ungrounded signal. Even though the input signal may only vary over a 5:1 range, the kit can be adjusted to give a greater operating speed range, such as 20:1, depending upon the potentiometer settings on the kit. Should it be desirable to easily select whether the drive speed follows the process controller or have the speed determined manually, order an Operator's Control Panel with an AUTOMATIC-MANUAL selector switch. In the AUTOMATIC position, the speed will follow the process controller. In the MANUAL position, the drive speed is determined by the main speed potentiometer setting. To utilize the preset speed function, install the 14C222 Kit, reconnect one jumper and install a control panel with the AUTOMATIC-MANUAL selector switch. In the AUTOMATIC setting, the drive speed will be determined by the setting of the potentiometer on the kit. In MANUAL mode, the main speed potentiometer determines the drive speed.

**Kit Model \* 14C222** ..... \$120 List  
**Factory Installed** ..... \$195 List

**REMOTE OPERATOR ADAPTER KIT** provides convenient terminals, plus buffering and filtering of sensitive signals when a remote operator station with a MinPak Plus is used. The buffering and filtering improves drive reliability and performance when using a remote station. This kit is not required when a local operator's panel is used with an enclosed MinPak Plus or with a Chassis MinPak Plus/FlexPak Plus drives. Also, add the Blank Plate (Model 14C200) with NEMA 4 Single-Phase MinPak Plus.

**Kit Model \* 14C220** ..... \$75 List  
**Factory Installed** ..... \$150 List  
**Blank Plate Model \* 14C200** ..... \$80 List  
**Factory Installed** ..... \$155 List

**REMOTE OPERATOR'S CONTROL STATIONS** - For Remote Operator's Control Station specification and pricing. Refer to page D-185.

**TEST METER ADAPTER KIT** provides a convenient means to measure and monitor MinPak Plus/FlexPak Plus regulator voltages. It acts as an interface between the regulator module and a user's voltmeter, which should have a minimum sensitivity of 20k ohms per volt.

**Kit Model \* 14C225** ..... \$100 List  
**Factory Installed** ..... \$175 List

**VOLTAGE/TACHOMETER-GENERATOR FOLLOWER KIT** enables the speed of the MinPak Plus/FlexPak Plus to be controlled automatically by a speed reference voltage from the DC tachometer-generator connected to an entirely separate machine. Thus, the speed of one motor will follow the speed of a master motor or machine. The kit will accept an input signal of 25 to 250 VDC to obtain maximum speed. The minimum permissible input voltage is 25 VDC to obtain maximum speed. The maximum permissible input voltage is 250 VDC. The input impedance is approximately 80k ohms. This Kit can also be used with an AUTOMATIC-MANUAL operators control panel.

**Kit Model \* 14C223** ..... \$100 List  
**Factory Installed** ..... \$175 List

## Local Operator's Control Panels For MinPak Plus Drives

| Description   | Functions Provided |                   |                    |                  |                          |                           | Model    | List Kit | Factory Installed List |
|---|--------------------|-------------------|--------------------|------------------|--------------------------|---------------------------|----------|----------|------------------------|
|   | Start/Stop         | Speed Setting Pot | Torque Setting Pot | Run/Jog Selector | Forward/Reverse Selector | Automatic Manual Selector |          |          |                        |
| Basic   | Yes                | Yes               | No                 | Yes              | No                       | No                        | * 14C201 | \$145    | \$220                  |
| Basic Plus Reversing <sup>(1)</sup>   | Yes                | Yes               | No                 | Yes              | Yes                      | No                        | * 14C202 | 145      | 220                    |
| Basic Plus Automatic/Manual <sup>(2)</sup>  | Yes                | Yes               | No                 | Yes              | No                       | Yes                       | * 14C203 | 145      | 220                    |
| Basic Plus Reversing and Automatic/Manual <sup>(1) (2)</sup>                            | Yes                | Yes               | No                 | Yes              | Yes                      | Yes                       | * 14C204 | 145      | 220                    |
| Basic Plus Torque Control   | Yes                | Yes               | Yes                | Yes              | No                       | No                        | * 14C205 | 145      | 220                    |
| Basic Plus Reversing and Torque Control <sup>(1)</sup>                                  | Yes                | Yes               | Yes                | Yes              | Yes                      | No                        | * 14C206 | 145      | 220                    |
| Basic Plus Torque Control and Automatic/Manual <sup>(2)</sup>                           | Yes                | Yes               | Yes                | Yes              | No                       | Yes                       | * 14C207 | 145      | 220                    |
| Basic Plus Reversing, Torque <sup>(1)</sup> Control and Automatic/Manual <sup>(2)</sup> | Yes                | Yes               | Yes                | Yes              | Yes                      | Yes                       | * 14C208 | 145      | 220                    |

(1) Add Contactor Reversing kit if non-regenerative drive

(2) Add one of the Follower kits: Instrument Interface Model Number 14C222, Voltage Follower Model Number 14C223 or Dancer Follower Model Number 14C230.

\* Normally carried in stock

## ADDITIONAL MODIFICATION KITS FOR NON-REGENERATIVE CONTROLLERS

In addition to the modifications on pages D-142 through D-143, the following are available on non-regenerative drives:

| Description                      | Page         | HP, Phase      | MinPak Plus   | FlexPak Plus |
|----------------------------------|--------------|----------------|---------------|--------------|
|                                  |              |                | Kit Model     |              |
| Automatic Reversing Kit          | D-143        | 1/4-5, 1-Phase | 14C226        | 14C226       |
| Double-Pole Input Disconnect Kit | on this page | 1/4-5, 1-Phase | 14C210-14C213 | N/A          |
| Reversing Contactor Kit          | D-145        | 1/4-3, 1-Phase | 14C217        | 14C293       |
|                                  |              | 1/4-5, 1-Phase | 14C218        | 14C293       |
| Tachometer Feedback Kit          | D-145        | All            | 14C221        | 14C221       |
| Torque Taper Kit                 | D-145        | 1/4-5, 1-Phase | 14C224        | 14C224       |

## ADDITIONAL MODIFICATION KITS FOR NON-REGENERATIVE DRIVES

**AUTOMATIC REVERSING KIT** offers an automatic reverse direction capability for single-phase MinPak Plus/FlexPak Plus drives. The Automatic Reversing Kit allows the drive to sequence off one armature contactor and then immediately sequence on the other drive contactor. The control can be either an external switch, such as a limit switch, or manual with the FORWARD-REVERSE selector switch. Dynamic braking should not be used with this kit.

This Kit also requires installing a Reversing contactor Kit (page D-145) Also, an Auxiliary Mounting Bracket (Model Number 14C209) for 1/4 - 1-1/2 HP MinPak Plus drive is required. See page D-142 for selection and pricing.

**NOTE:** For high cyclic duty applications, several reversals each minute, it is advisable to use a Regenerative drive which offers solid-state reversing and eliminates contactor operations for each reversal.

**Single-phase Regenerative Drives only**  
**Kit Model Number \* 14C226 . . . . . \$115 List**  
**Factory Installed . . . . . \$190 List**

**DOUBLE-POLE INPUT DISCONNECT KIT** replaces the existing single pole breaker in the 1/4-5 HP single-phase MinPak Plus drive. The double-pole device, which opens both sides of the AC line, is sometimes required by local codes, and offers a higher degree of protection since all power is removed from the control circuits. Interrupting capacity is in symmetrical RMS amps.

| Drive       |              | Double-pole Input Disconnect Kit |                |          |                        |
|-------------|--------------|----------------------------------|----------------|----------|------------------------|
| Rating (HP) | Model Number | Model Number                     | Interrupt Cap. | Kit List | Factory Installed List |
| 1/4-3/4     | 14C10/14C20  | 14C210                           | 1000           | \$85     | \$160                  |
| 1/2 - 1-1/2 | 14C11/14C21  | 14C211                           | 5000           | 85       | 160                    |
| 2-3         | 14C12/14C22  | 14C212                           | 5000           | 110      | 185                    |
| 5           | 14C13/14C23  | 14C213                           | 5000           | 175      | 250                    |

\* Normally carried in stock

# MinPak Plus FlexPak Plus DC Drives

**REVERSING CONTACTOR KIT** offers a convenient method to change the direction of motor rotation. The drive is supplied with a single motor contactor which offers unidirectional operation. By adding this Reversing Contactor Kit, the operator can select the direction of rotation by simply depressing the FOR or REV selector switch.

**NOTE:** When ordering this Reversing Kit, it is also necessary to select an operator's control with forward-reverse capability. If automatic reversing is required see Automatic Reversing Kit, page D-144.

## MinPak Plus

| Drive Rating      | Reversing Contactor Kit Model | Kit List <sup>(1)(2)</sup> | Factory Installed List |
|-------------------|-------------------------------|----------------------------|------------------------|
| 1/4-3 HP, 1-Phase | * 14C217                      | \$100                      | \$175                  |
| 5 HP, 1-Phase     | * 14C218                      | 130                        | 205                    |

- (1) Factory installation of these kits is recommended.
- (2) Three-phase kits have been discontinued.

## FlexPak Plus

| Drive Rating      | Reversing Contactor Kit Model | Kit List <sup>(1)</sup> | Factory Installed List |
|-------------------|-------------------------------|-------------------------|------------------------|
| 1/4-3 HP, 1-Phase | * 14C293                      | \$200                   | \$275                  |

- (1) Factory installation of these kits is recommended.

**TACHOMETER FEEDBACK KIT** interfaces between tachometer-generator and the MinPak Plus/FlexPak Plus regulator when speed regulation is used. This kit will accept either an AC or DC tachometer-generator with a maximum output voltage of 175 volts.

Advantage Of Speed Regulation: Normal voltage regulation using IR drop compensation provides 1-2% speed regulation with a 95% load change. However, changes in other variables (temperature, frequency and voltage) can cause significantly greater speed changes, sometimes as much as 15%.

For improved speed regulation, add a motor-mounted tachometer. Feedback from this tachometer will give 1% speed regulation with a 95% load change, and regulation due to other variables will be held to 2% of motor base speed. In addition, speed regulation of .5% is obtainable by using a high performance tachometer-generator (BC-42 or equivalent).

**NOTE:** Similar kit included and mounted on all regenerative MinPak Plus/FlexPak Plus drives as standard.

**Kit Model \* 14C221** ..... \$100 List  
**Factory Installed** ..... \$175 List

**TORQUE TAPER KIT** allows fine adjustment of the slope and break point of drive speed-torque curve.

It is ideal for simple center-driven winders which require nearly constant tension when operating in the voltage control range only. This requires the motor current (torque) limit to increase as the motor speed decreases.

**NOTE:** This kit is only available on the non-regenerative single-phase MinPak Plus/FlexPak Plus drives.

**Kit Model \* 14C224** ..... \$150 List  
**Factory Installed** ..... \$225 List

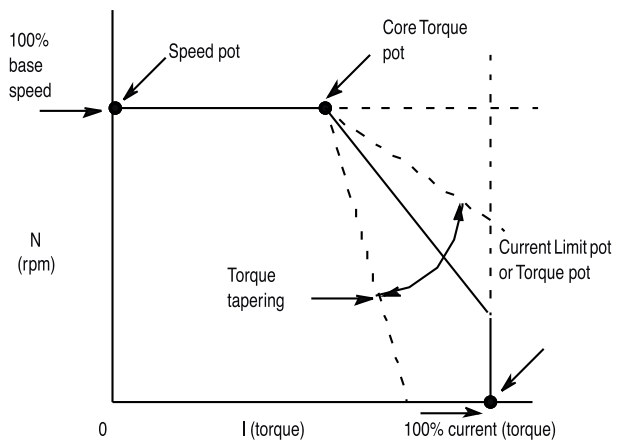

Drive Speed-Torque Curve

\* Normally carried in stock

# NOTES

Introduction

AC Drives

Analog DC Drives

Digital DC Drives

Options & Accessories

Product Demonstrators  
and Training