

AHP-1152

15" XGA Touch Panel Computer With Intel® Atom™ D510 1.66 GHz Processor

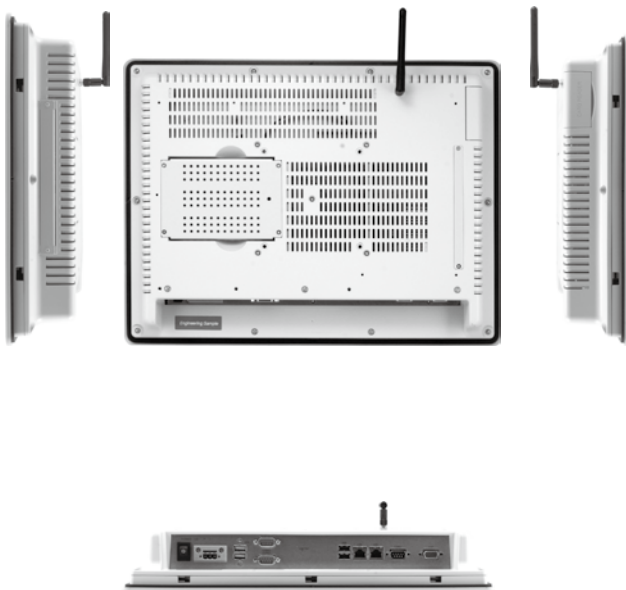

Features

- Onboard Intel® Atom™ D510 1.66GHz
- 15" 250 Nits XGA CCFL Backlight
- 15" 800 Nits XGA LED Backlight (Optional)
- Fanless Operation
- Dual Mini Card For 3G/ WiFi Card
- Slim Design
- RF ID/ WiFi (Optional)



Specifications

System	
Processor	Intel® Atom™ D510 ,1.66 GHz
System Memory	DDR2 SODIMM, Up to 2 GB
LCD/CRT Controller	Integrated in Processor, shared memory up to 224MB
Ethernet	10/100/1000Base-TX, RJ-45 x 2
I/O Port	USB 2.0 x 4, RS-232 x 2, RS-232/422/485 x 1, LAN x 2, VGA x 1
Storage Disk Drive	2.5" SATA Hard Disk Driver /CompactFlash™ Slot (Internal)
Expansion Slot	Mini card x 2
OS support	Windows® CE 6.0, Windows® XP Embedded, Windows® XP, Windows® 7, Windows® Embedded Standard 7, Linux Fedora
Mechanical	
Construction	IP-65 certified Plastic front panel Plastic Gray panel
Color	PMS 5425C +Gray
Mounting	VESA 75/100
Dimension	16"(W) x 12.2"(H) x 2.6"(D) (407mm x 310.5mm x 65mm)
Carton Dimension	20.67"(W) x 18.31"(H) x 9.1"(D) (525mm x 465mm x 230mm)
Gross Weight	11.9 lb (5.4 kg)
Net Weight	9.7 lb (4.4 kg)
Environmental	
Operating Temperature	32°F ~ 122°F(0°C ~ 50°C)
Storage Temperature	-4°F ~ 140°F(-20°C ~ 60°C)
Storage Humidity	5%~90% @ 40°C; non-condensing
Vibration	3 g rms/ 5~ 500Hz/ operation – With HDD
Shock	20 G peak acceleration (11 msec. duration)
EMC	CE /FCC class A
Power Supply	
DC input	DC 12V
LCD	
Display type	15" TFT-LCD
Max Resolution	1024 x 768
Max. Colors	262K colors
Luminance	250 cd/m ² / 800 cd/m ²
Viewing Angle	170°(H), 160°(V) / 160°(H), 140°(V)
Back Light	CCFL /LED
Back Light MTBF (hours)	30,000/ 60,000
Touchscreen	
Type	5-wire, Analog Resistive
Resolution	2048x2048
Light Transmission	>80%
Life time	35 Million activations

AHP-1152

Dimension

Unit: mm

Cutout Size: 394mm x 297.5mm

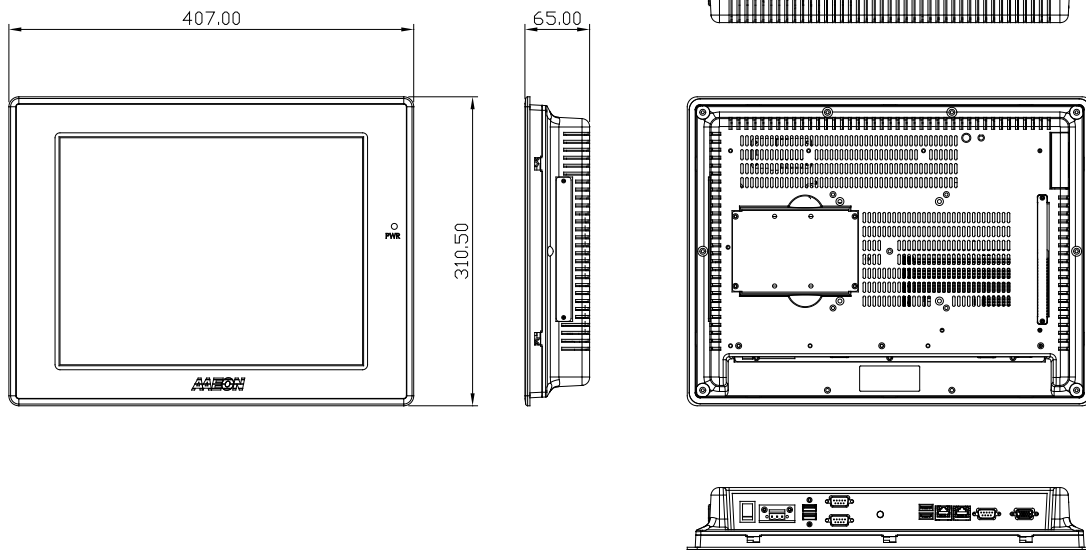

Ordering Information

- **TF-AHP-1152HTT-A1-1000**
HMI Panel PC, Intel® Atom™ D510 1.66GHz, 15" TFT 250 nits, Fanless, DC 12V, R-TS, 1 G RAM
- **TF-AHP-1152STT-A1-1000**
HMI Panel PC, Intel® Atom™ D510 1.66GHz, 15" TFT 800 nits, Fanless, DC 12V, R-TS, 1 G RAM

Optional Accessories

- **ARM-DR075-0**
DIN Rail Kit with VESA 75mm Standards
- **ARM-WK075-0**
Wallmount Kit for VESA 75/100mm Standard Screw Holes
- **STAND-8150B0**
Desktop Stand with VESA 100mm Standard
- **1702031830**
Power Cord (US Type)
- **1702031831**
Power Cord (European Type)
- **1757908401**
12V 84W Power Adapter
- **WLAN Kit, WiFi 802.11 b/g, and Bluetooth v2.0 + EDR**
- **RF-ID Kit**

AHP-1122

12.1" XGA Touch Panel Computer with Intel® Atom™ D510 1.66 GHz Processor

01

AHP Series - Industrial HMI Touch Panel Solutions

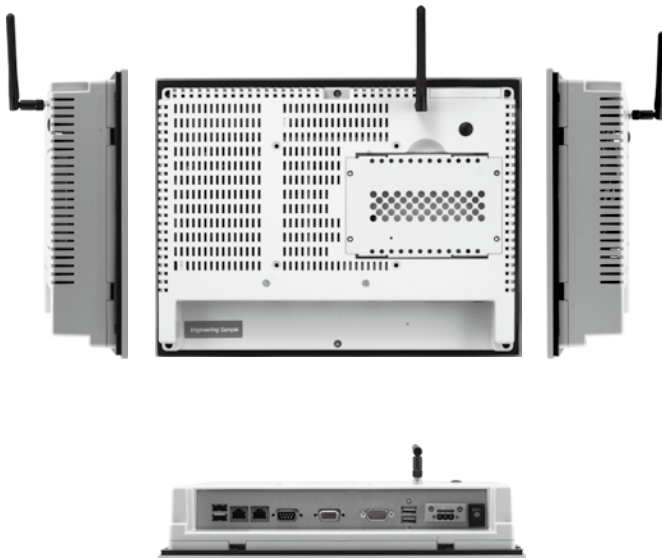
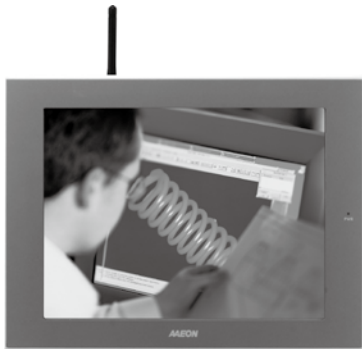

Features

- Onboard Intel® Atom™ D510 1.66GHz
- 12.1" 500 Nits XGA LED Backlight
- 12.1" 1000 Nits XGA LED Backlight
- Fanless Operation
- Dual Mini Card For 3G/WiFi Card
- Slim Design
- RF ID / WiFi (Optional)

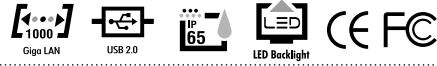

Specifications

System	
Processor	Intel® Atom™ D510 ,1.66 GHz
System Memory	DDR2 SODIMM, Up to 2 GB
LCD/CRT Controller	Integrated in Processor, shared memory up to 224MB
Ethernet	10/100/1000Base-TX, RJ-45 x 2
I/O Port	USB 2.0 x 4, RS-232 x 1, RS-232/422/485 x 1, LAN x 2, VGA x 1
Storage Disk Drive	2.5" SATA Hard Disk Driver /CompactFlash™ Slot (Internal)
Expansion Slot	Mini card x 2
OS support	Windows® CE 6.0, Windows® XP Embedded, Windows® XP, Windows® 7, Windows® Embedded Standard 7, Linux Fedora
Mechanical	
Construction	IP-65 certified Plastic front panel Plastic back panel
Color	PMS 5425C + Gray
Mounting	VESA 75
Dimension	12.5"(W) x 9.6"(H) x 2.5"(D)(317mm x 243mm x 64mm)
Carton Dimension	16.6"(W) x 7.7"(H) x 15.9"(D) (422mm x 196mm x 404mm)
Gross Weight	9.3 lb (4.2 kg)
Net Weight	7 lb (3.2 kg)
Environmental	
Operating Temperature	32°F ~ 122°F (0°C ~ 50°C)
Storage Temperature	-4°F ~ 140°F (-20°C ~ 60°C)
Storage Humidity	5%~90% @ 40°C; non-condensing
Vibration	3 g rms/ 5~ 500Hz/ operation – With HDD
Shock	20 G peak acceleration (11 msec. duration)
EMC	CE /FCC class A
Power Supply	
DC input	DC 12V
LCD	
Display type	12.1" TFT-LCD
Max Resolution	1024 x 768
Max. Colors	262K colors
Luminance	500 cd/m ² / 1000 cd/m ²
Viewing Angle	160°(H), 160°(V)/ 160°(H), 140°(V)
Back Light	LED
Back Light MTBF (hours)	50,000/ 60,000
Touchscreen	
Type	5-wire, Analog Resistive
Resolution	2048x2048
Light Transmission	>80%
Life time	35 Million activations

AHP-1122

Dimension

Unit: mm

Cutout Size: 303mm x 229mm

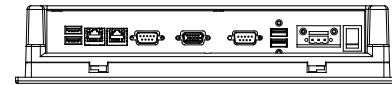
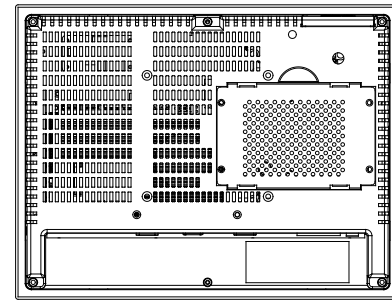
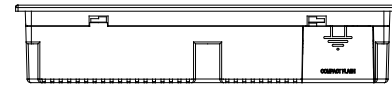
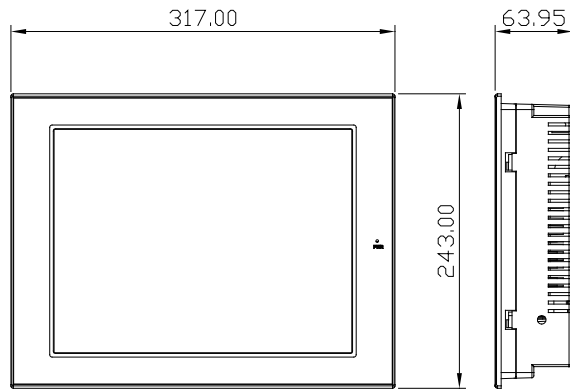

Ordering Information

- **TF-AHP-1122HTT-A1-1000**
HMI Panel PC, Intel® Atom™ D510 1.66GHz, 12.1" TFT 500 nits, Fanless, DC 12V, R-TS, 1 G RAM
- **TF-AHP-1122STT-A1-1000**
HMI Panel PC, Intel® Atom™ D510 1.66GHz, 12.1" TFT 1000 nits, Fanless, DC 12V, R-TS, 1 G RAM

Optional Accessories

- **ARM-DR075-0**
DIN Rail Kit with VESA 75mm Standards
- **ARM-WK075-0**
Wallmount Kit for VESA 75/100mm Standard Screw Holes
- **STAND-8150B0**
Desktop Stand with VESA 100mm Standard
- **1702031830**
Power Cord (US Type)
- **1702031831**
Power Cord (European Type)
- **1757908401**
12V 84W Power Adapter
- **WLAN Kit, WiFi 802.11 b/g, and Bluetooth v2.0 + EDR**
- **RF-ID Kit**

AHP-1081

8.4" SVGA LED LCD With Intel® Atom™ N270 1.6 GHz Processor



Features

- Intel® Atom™ N270 1.6GHz Onboard
- 8.4" 450 Nits SVGA LED Backlight
- Fanless Operation
- IP-65 Front Bezel
- Slim Design: 50 mm
- RFID/ WiFi (Optional)



Specifications

System	
Processor	Intel® Atom™ N270 ,1.6 GHz
System Memory	DDR2 SODIMM, up to 2GB
LCD/CRT Controller	Integrated in Processor, shared memory up to 224MB
Ethernet	10/100/1000Base-TX, RJ-45 x 2
I/O Port	USB 2.0 x 2, RS-232 x 1, RS-232/422/485 x 1, LAN x 2, VGA x 1
Storage Disk Drive	2.5" SATA Hard Disk Driver /CompactFlash™ Slot (Internal)
Expansion Slot	Mini-PCI x 1
OS support	WinCE 6.0, Window XP Embedded, Window XP, Window 7, Window Embedded Standard 7, Linux Fedora
Mechanical	
Construction	IP-65 certified Plastic front panel, Aluminum back panel
Color	Front Panel: Gray, Back panel: Light Gray
Mounting	VESA 75
Dimension	9.65" x 7.2" x 1.97" (245mm x 183mm x50mm)
Gross Weight	4.4 lb (2 Kg)
Net Weight	3.3 lb (1.5 Kg)
Environmental	
Operating Temperature	32°F ~ 122°F (0°C ~ 50°C)
Storage Temperature	-4°F ~ 158°F (-20°C ~ 70°C)
Storage Humidity	5%~90% @40°C, non-condensing
Vibration	1 g rms/ 5~ 500Hz/ operation – With HDD
Shock	20 G peak acceleration (11 msec. duration)
EMC	CE /FCC class A
Power Supply	
DC input	DC 12V
LCD	
Display type	8.4" TFT-LCD
Max Resolution	800 x 600
Max. Colors	16.2M colors
Luminance	450 cd/m ²
Viewing Angle	160°(H), 140°(V)
Back Light	LED
Back Light MTBF (hours)	50,000
Touchscreen	
Type	5-wire, Analog Resistive
Resolution	2048x2048
Light Transmission	>80%
Life time	35 Million activations

AHP-1081

Dimension

Unit: mm

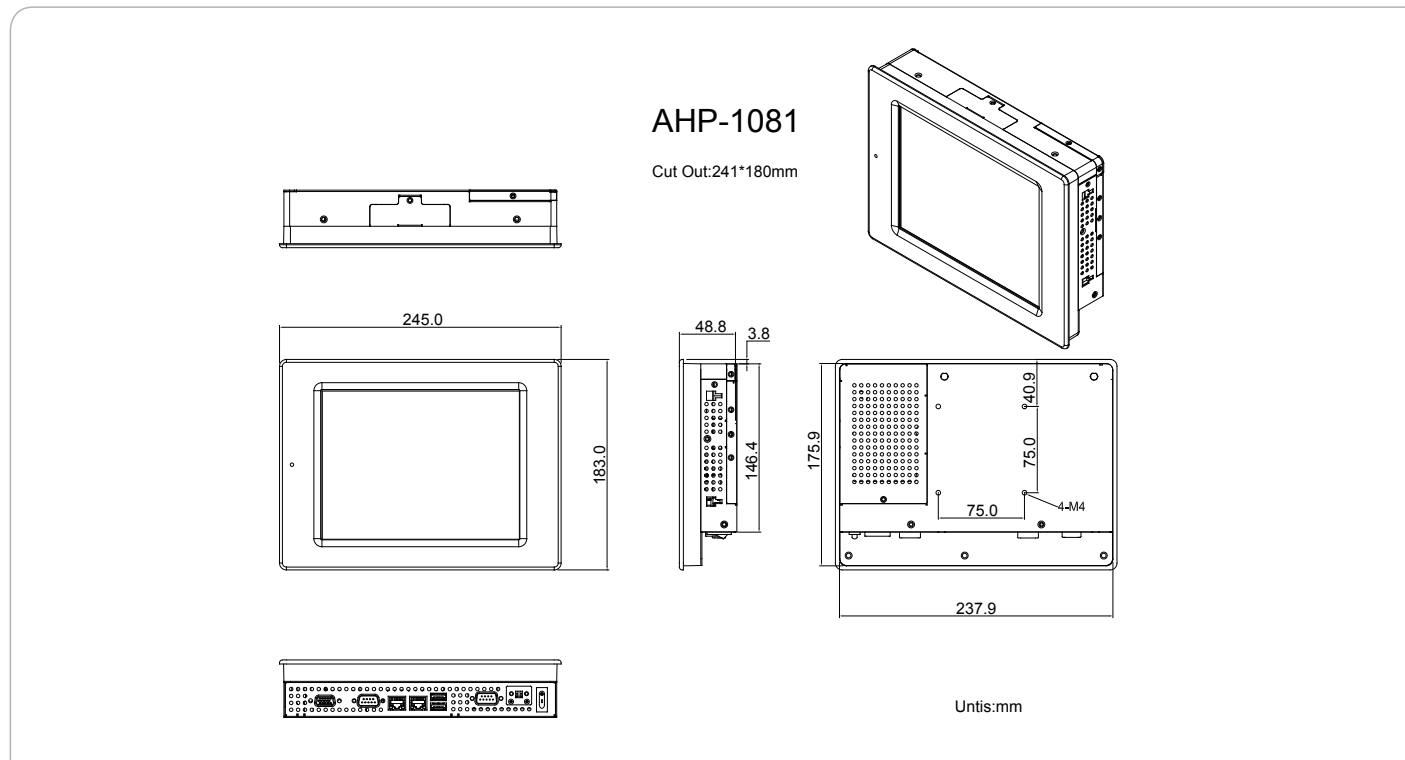

Ordering Information

• TF-AHP-1081HTT-A1-1000

HMI Panel PC, Intel® Atom™ N270 1.6GHz, 8. 4" LCD with 450nits Backlight, DC 12V, 5-wire R-TS, 1G RAM

Optional Accessories

- **ARM-DR075-0**
DIN Rail Kit with VESA 75mm Standards
- **ARM-WK075-0**
Wallmount Kit for VESA 75/100mm Standard Screw Holes
- **1757904005**
12V 40W Power Adapter
- **1702031830**
Power Cord (US Type)
- **1702031831**
Power Cord (European Type)
- **9741850R00**
Wireless LAN Kit. IEEE 802.11b/g.
- **GSM/GPS Kit**
- **RF-ID Kit**

AHP-1070

7" WVGA LED LC With TI OMAP 600 MHz Processor

01

AHP Series - Industrial HMI Touch Panel Solutions



Features

- Onboard TI OMAP 600MHz
- 7" 300 Nits WVGA LED Backlight
- Fanless Operation
- 256MB Flash ROM, 128MB DDR
- Slim Design: 45 mm
- WiFi And 3G/GPS (Optional)

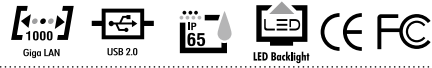

Specifications

System	
Processor	TI OMAP 600 MHz
System Memory	LP DDR 128 MB RAM
LCD/CRT Controller	Integrated in TI Processor
Ethernet	10/100Base-TX,RJ-45 x 1
I/O Port	RS-232 x 1,RS-232/422/485 x 1, USB 2.0 x 2, USB client x 1, LAN x 1, VGA out x 1
Storage Disk Drive	256 MB NAND FLASH on board /SD card x 1 Expansion
Expansion Slot	Mini card x 2 (USB interface only)
OS support	Windows® CE 6.0, Linux (AAEON image available soon)
Mechanical	
Construction	IP-65, NEMA 4 rugged protection, plastic front bezel
Color	Bezel: Patone 5425C, Rear cover: RAL 7040
Mounting	VESA 75
Dimension	8.8(W)x 6.14(H)x 1.77(D) (225mm x156mm x 45mm)
Carton Dimension	11.4(W)x 7.48(H)x 9(D) (290mm x190mm x 230mm)
Gross Weight	4.41 lb (2 kg)
Net Weight	1.54 lb (0.7 kg)
Environmental	
Operating Temperature	32°F ~ 122°F (0°C ~ 50°C)
Storage Temperature	-4°F ~ 140°F (-20°C ~ 60°C)
Storage Humidity	5%~90% @ 40°C; non-condensing
Vibration	3g rms/ 5~ 500Hz/ operation – With SD
Shock	20 G peak acceleration (11 msec. duration)
EMC	CE /FCC class A
Power Supply	
DC input	DC 12V
LCD	
Display type	7" TFT-LCD
Max Resolution	800 x 480
Max. Colors	262K colors
Luminance	300 cd/m ²
Viewing Angle	140°(H), 120°(V)
Back Light	LED
Back Light MTBF (hours)	30,000
Touchscreen	
Type	4-wire, Analog Resistive
Resolution	2048x2048
Light Transmission	>80%
Life time	10 Million activations

AHP-1070

Dimension

Unit: mm

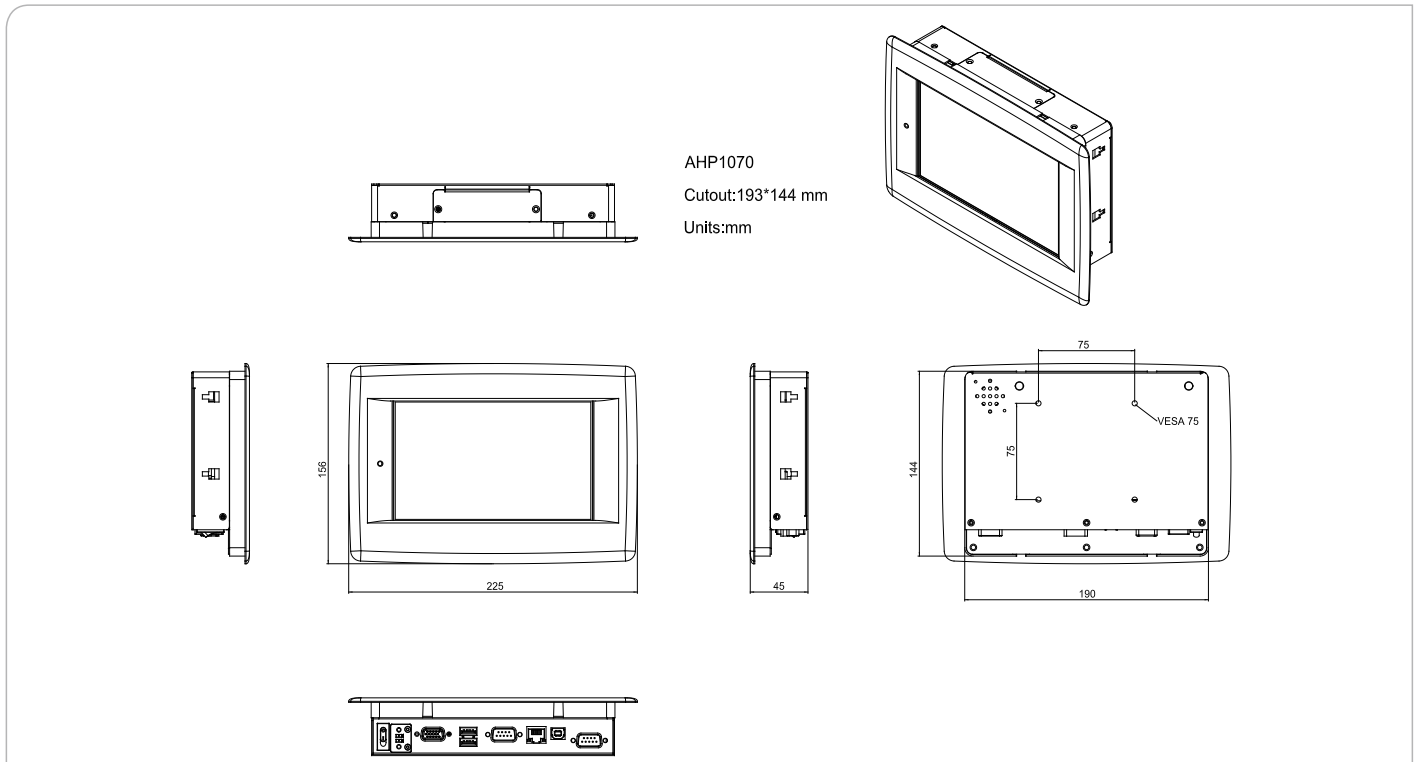

AHP1070
Cutout:193*144 mm
Units:mm

Ordering Information

- **TF-AHP-1070HTT-A1-1010**
HMI Panel PC, TI OMAP 600MHz, 7" LCD with 300nits B/L ,R-TS, 256MB ROM ,128 MB RAM ,WINCE 6.0

Optional Accessories

- **AARM-DR075-0**
DIN Rail Kit with VESA 75mm Standards
- **ARM-WK075-0**
Wallmount Kit for VESA 75/100mm Standard Screw Holes
- **1757904005**
12V 40W Power Adapter
- **1702031830**
Power Cord (US Type)
- **1702031831**
Power Cord (European Type)
- **1757904005**
12V 40W Power Adapter
- **3G/GPS Kit**
- **WLAN Kit ,IEEE802.11 b/g**

ARM-DR075-0

DIN Rail Kit For AOP-8060 (VESA 75/100)

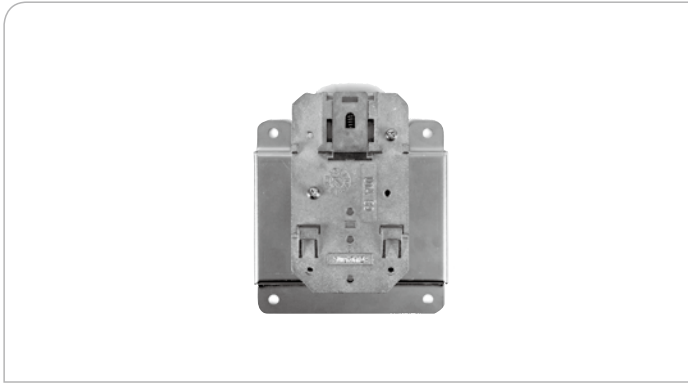

Ordering Information

- **ARM-DR075-0**
DIN Rail Kit with VESA 75/100mm Standard

STAND-8150B0

Desktop Stand For AOP-9150/ 9120/ 8120/ 8150, OPD-212A/ 215A/ 215E (VESA 100)



Ordering Information

- **STAND-8150B0**
VESA 100mm Standard Desktop Stand, Dark Blue Color

Dimension

Unit: mm

