

Main Features

- ◆ Low Power COM Express CPU Module
- ◆ Onboard Intel® Atom™ Dual Core D510 1.66GHz Processor
- ◆ Intel® ICH8M Chipset
- ◆ Support DDR2 667 and 800 SO-DIMM up to 2GB
- ◆ Intel® PCI Express GbE 82574L
- ◆ Support 3 x SATA, 1 x IDE, 8 x USB2.0 for fast peripherals
- ◆ Micro COM Express Type II supports up to 5 Express lanes, 32 bit PCI interface and one IDE and Gigabit LAN

Product Overview

ICES 252 is a COM Express module that features Intel® Atom™ D510 1.66GHz and ICH8M in small foot print. ICES 252 provides outstanding performance in the combination of high computing power and low thermal dissipation.

ICES 252 supports DDR2 667 SO-DIMM memory up to 2GB, and supports 3 x SATA, 1 x IDE, 8 x USB2.0 for fast peripherals.

ICES 252 is type 2 COM Express Module support up to 5 Express lanes, 32 bit PCI interface and one IDE and Gigabit LAN.

Specifications

CPU Support

- ◆ Onboard Intel® Atom™ Dual Core D510 1.66GHz Processor

Chipset

- ◆ Intel® ICH8M chipsets

Main Memory

- ◆ Support one un-buffered non-ECC DDR2 SO-DIMM 667 and 800 up to 2GB

BIOS

- ◆ AMI System BIOS
- ◆ SPI ROM
- ◆ Plug & Play support
- ◆ Advanced Power Management and Advanced Configuration & Power Interface support

Display

- ◆ Intel® D510 integrated graphics solution with dynamic video memory allocation
- ◆ Analog monitor with pixel resolution up to 2048 x 1536 @60Hz
- ◆ Support Single channel for 18 bit
- ◆ LFP (local flat panel) LVDS interface

On-board LAN

- ◆ Intel® PCI Express GbE 82574L x 1
- ◆ Support PXE LAN boot function
- ◆ Support Wake on LAN function

Other Interfaces

- ◆ One 3pin fan connector (90 degree, 12V)

Storage

- ◆ 3 x SATA
- ◆ 1 x IDE

Interface

- ◆ Reset signal
- ◆ 8 GPIO lines (GPI 0-3 and GPO0-3), CMOS Level (0/3.3V)
- ◆ I2C Interface/SMBus Interface
- ◆ USB 2.0 x 8
- ◆ PATA

Extension

- ◆ One 32-bit PCI V2.3 interface
- ◆ One PCI express: 5 Lanes (via dip switch for 5 x 1 or 1 x 1+ 1 x 4)

Block Diagram

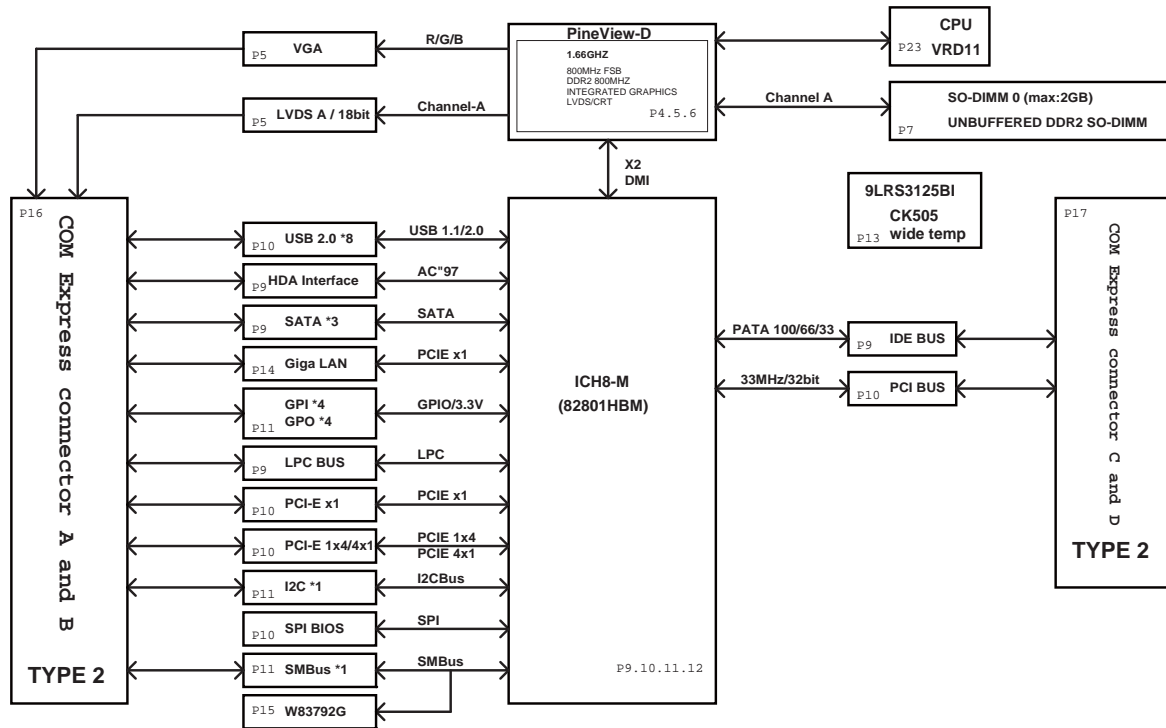

Other Interfaces

- One 3pin fan connector (Reserved, 90 degree, 12V)

COM Express Connector

- AB connector
VGA/LVDS/8 x USB/HD Audio interface/2 x SATA/LAN/GPIO(3.3V)/LPC bus/
1 x PCIe x4/1 x PCIe x1/SMBus/I2C/SPI BIOS
- CD connector, IDE, PCI

Power Requirements

- +12Vdc, 3.3V battery, +5Vsb power input
- Support both AT and ATX power supply mode

Power Management

- ACPI 2.0 compliant with battery support. Also supports Suspend to RAM (S3)

System Monitor

- Monitoring of 4 voltages, 2 temperatures and 1 fan Speed
- 4 voltage (For +5V, +12V, Vcore, +3.3V)
- 2 Temperatures (CPU and one external Temperature Sensor)

Carrier Board

- ICEB 8050
- ICEB 9030-MR

Dimensions

- 95mm (W) x 95mm (L)

Environment

- Operating temperature: -20°C to 60°C
- Storage temperature: -20°C to 85°C
- Relative humidity:
10% to 97% (operating, non-condensing)
5% to 97% (non-operating, non-condensing)

Certifications

- CE approval
- FCC Class A

Ordering Information

- **ICES 252 (P/N: 10K00025200X0)**

Micro COM Express Type II Module Atom™ D510 1.66GHz COM Express Module