

# Thermo-cooler Series HRG



## How to Order

HRG 010 - A - [ ]

Cooling capacity

010	-A	Cooling capacity 9.0/9.5 kW (50/60 Hz)
	-W	Cooling capacity 10.0/11.0 kW (50/60 Hz)
015	-A	Cooling capacity 13.0/14.5 kW (50/60 Hz)
	-W	Cooling capacity 14.5/16.5 kW (50/60 Hz)

Option

Nil	None
A	With casters
B	With earth leakage breaker
C	With communications function (RS485)

\* Refer to page 21 for the specifications of each option.

Cooling method

A	Air-cooled refrigeration
W	Water-cooled refrigeration

## Specifications

### HRG010, 015

Model		HRG010		HRG015	
Cooling method		Air-cooled refrigeration	Water-cooled refrigeration	Air-cooled refrigeration	Water-cooled refrigeration
Refrigerant		R407C (HFC)			
Control method		Compressor ON/OFF control			
Ambient temperature/humidity <sup>Note 1)</sup>		Temperature: -5 to 40°C, Humidity: 30 to 70%RH			
Circulating fluid system	Circulating fluid <sup>Note 2)</sup>	Clear water, Deionized water, 15% ethylene glycol aqueous solution			
	Temperature range setting <sup>Note 1)</sup> (°C)	5 to 35			
	Cooling capacity <sup>Note 3)</sup> (50/60 Hz) (kW)	9.0/9.5 (at 20°C)	10.0/11.0 (at 20°C)	13.0/14.5 (at 20°C)	14.5/16.5 (at 20°C)
	Heating capacity <sup>Note 4)</sup> (kW)	—	—	—	—
	Temperature stability <sup>Note 5)</sup> (°C)	±1.0			
	Pump capacity <sup>Note 6)</sup> (50/60 Hz) (MPa)	0.29/0.33 (at 37/49 L/min, total lifting height 25/25 m)		0.28/0.31 (at 42/53 L/min, total lifting height 25/25 m)	
	Rated flow <sup>Note 7)</sup> (50/60 Hz) (L/min)	37/49		42/53	
	Tank capacity (L)	40		60	
	Port size	Rc3/4			
	Wetted parts material	Stainless steel, Brass, PVC, Nylon 12, Polyurethane, Copper brazing (Heat exchanger)		Stainless steel, Brass, PVC, Nylon 12, Polyurethane, Copper brazing (Heat exchanger)	
Facility water system	Temperature range (°C)	—	5 to 32	—	5 to 32
	Pressure range (MPa)	—	0.3 to 0.5	—	0.3 to 0.5
	Required flow rate <sup>Note 8)</sup> (50/60 Hz) (L/min)	—	33/34	—	38/40
	Port size	—	Rc1/2	—	Rc3/4
	Wetted parts material	Stainless steel, Brass, Synthetic rubber, Copper brazing (Heat exchanger)			
	Power supply	3-phase 200 VAC 50 Hz, 3-phase 200 to 220 VAC 60 Hz Allowable voltage fluctuation ±10%			
	Applicable earth leakage breaker capacity <sup>Note 9)</sup> (A)	40		60	
	Rated operating current (50/60 Hz) (A)	14/16	12/12.5	21/22	18/19
Electrical system	Rated power consumption (50/60 Hz) (kW)	4.0/5.0	3.2/3.8	5.5/6.7	4.7/5.8
	Remote operation signal input	Remote startup with 8 mA input at 24 VDC, shutdown at 0 VDC			
	Operation signal output	Relay contact output (switch closed when operating, switch open when stopped, switch open when shut down)			
	Alarm stop signal output	Relay contact output (switch closed when alarm is turned off, switch open when alarm is turned on, switch closed when shut down)			
	Alarm	Refer to page 19.			
	Weight <sup>Note 10)</sup> (kg)	205	200	230	220

Note 1) It should have no condensation.

During seasons or in locations where the ambient temperature is likely to fall below freezing point, please use ethylene glycol aqueous solution.

Note 2) If clear water is used, please use water that conforms to Water Quality Standards of the Japan Refrigeration and Air Conditioning Industrial Association (JRA GL-02-1994 cooling water system - circulating type - make-up water). If deionized water is used, supply water with electrical conductivity of 1 μS/cm or more (or electrical resistivity of 1 MΩ·cm or less).

If ethylene glycol aqueous solution is used, maintain the concentration at 15%.

Note 3) ① Ambient temperature: 32°C, Facility water temperature: 25°C (water-cooled refrigeration), ② Circulating fluid temperature: 20°C, ③ Circulating fluid flow rate: Values at rated circulating fluid flow rate.

Note 4) Thermo-cooler specifications do not have heating capability.

Note 5) Value with a stable load without turbulence in the operating conditions. It may be out of this range depending on operating conditions.

Note 6) The capacity at the Thermo-cooler outlet when the circulating fluid temperature is 20°C.

Note 7) Required flow rate for cooling capacity or maintaining the temperature stability.

When used below the rated flow, open the standard by-pass valve and maintain a circulating fluid flow rate equivalent to the rated flow.

Also, use the individually sold, "By-pass Piping Set" (Refer to pages 22 through to 25).

Note 8) Required flow rate when a load for the cooling capacity is applied at a facility water temperature of 32°C.

Note 9) Purchase an earth leakage breaker with current sensitivity of 30 mA separately. (A product with an optional earth leakage breaker (option B) is also available. Refer to "How to Order".)

Note 10) Weight in the dry state without circulating fluids

**Cooling Capacity**

**HRG010-A**

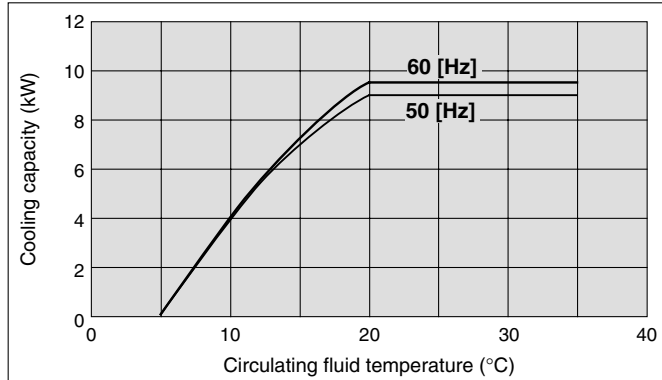

**HRG010-W**

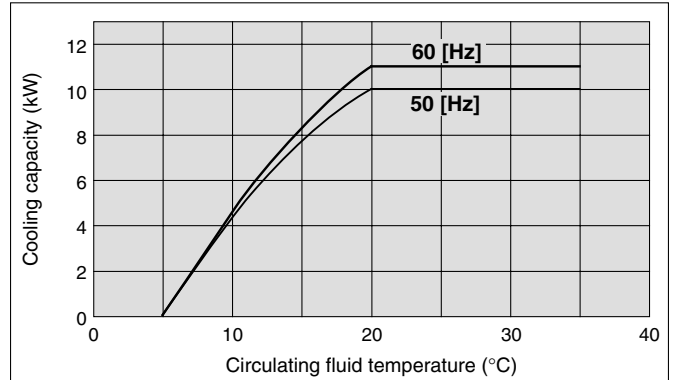

**HRG015-A**

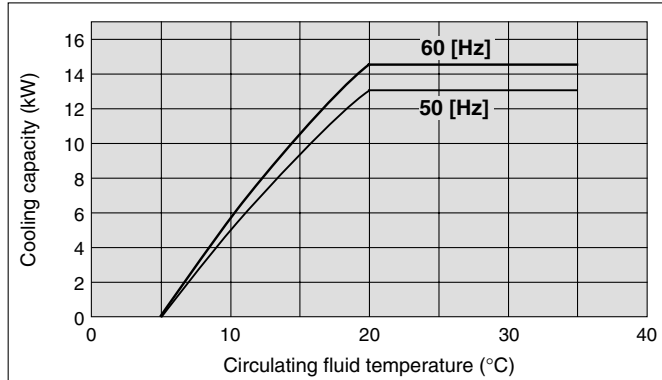

**HRG015-W**

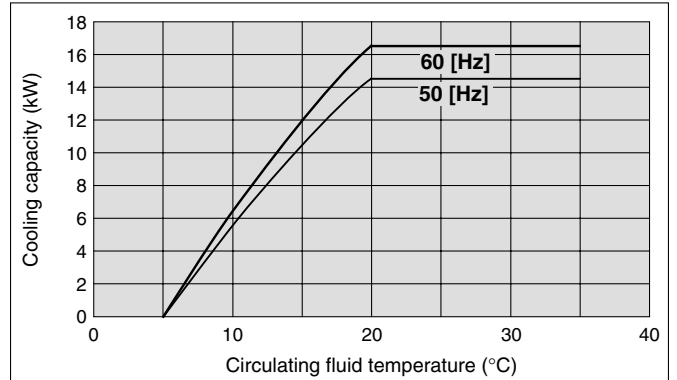

**Pump Capacity**

**HRG010-A, HRG010-W**

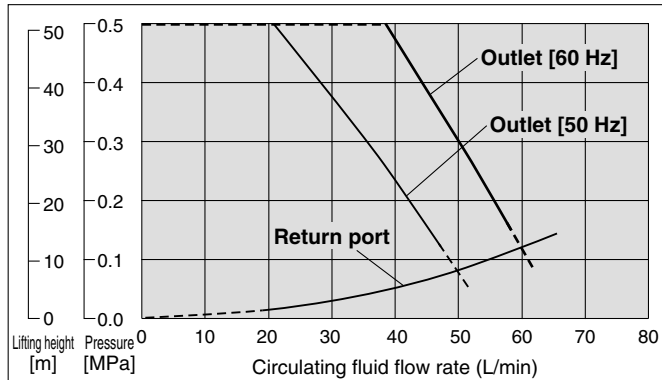

**HRG015-A, HRG015-W**

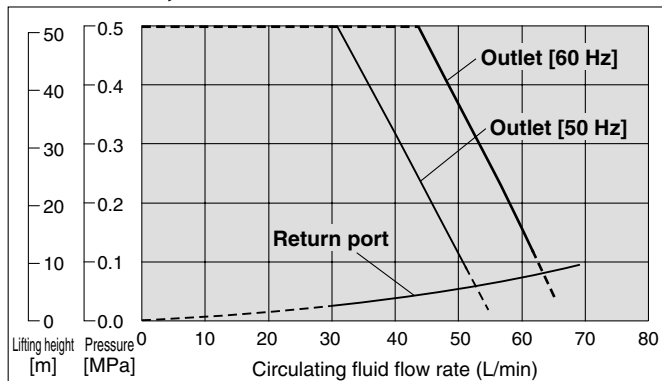

\* For all common models, temperature stability will decline in the flow rate range where circulating fluid is deduced (dotted line). Also, in this range, the circulating fluid outlet pressure will exceed the maximum operating pressure (0.5 MPa) (HRG010 to HRG015).

**Facility Water Required Flow Rate**

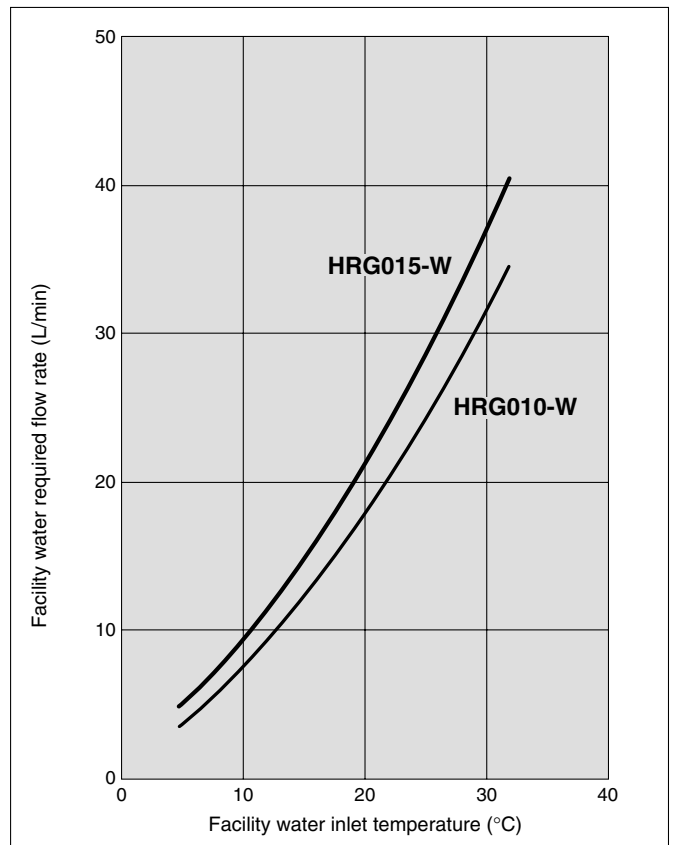

\* This is the required flow rate of facility water at the rated cooling capacity and circulating fluid flow, operating at 60 Hz, when the facility water inlet temperature is between 5°C and 32°C.

HRG  
HRS  
HRZ  
HRZD  
HRW  
HEC  
HEB  
HED  
Technical Data  
Related Products

# Series HRG

## Dimensions: Air-Cooled Refrigeration

### HRG010-A (-A)

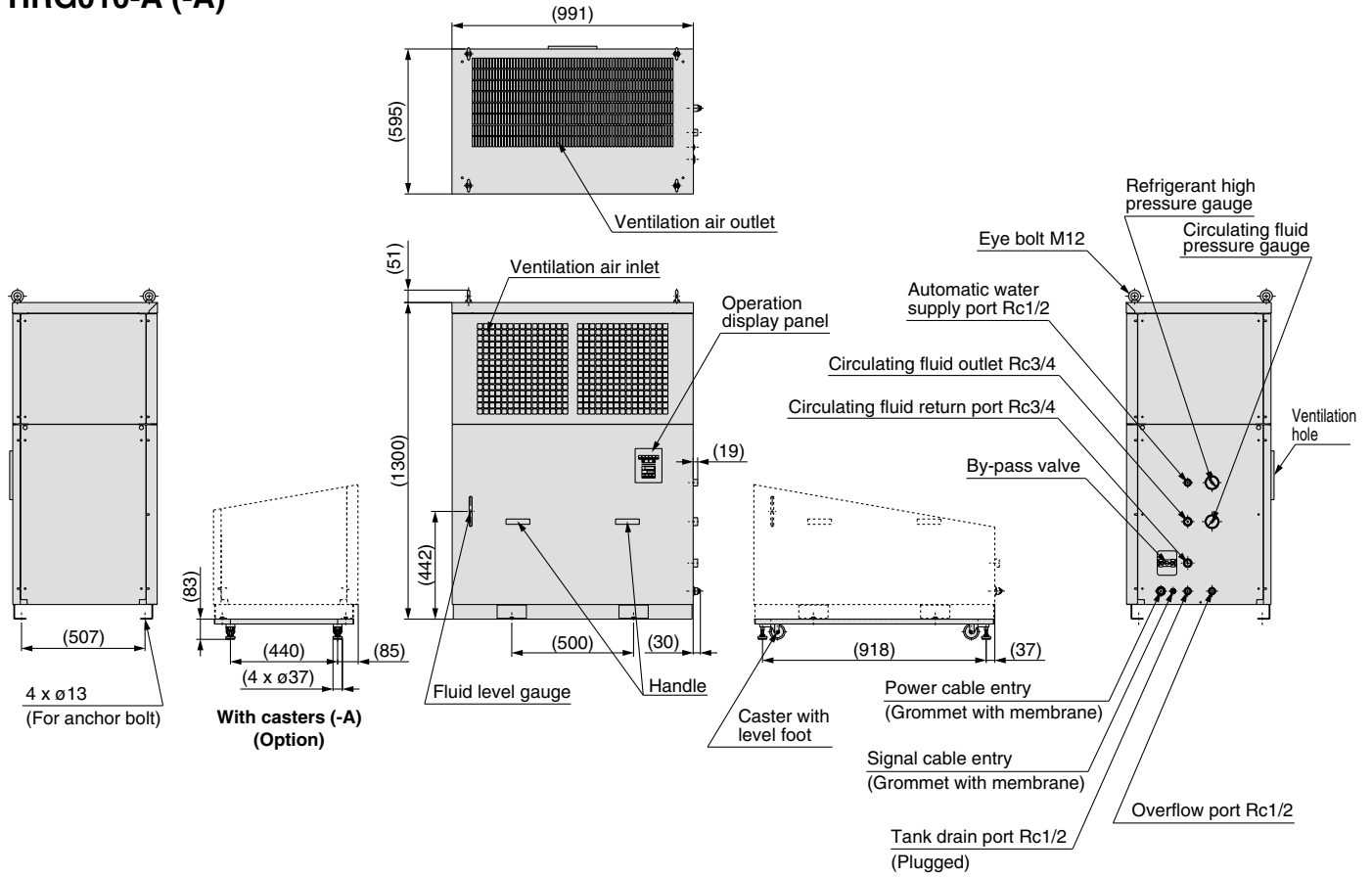

### HRG015-A (-A)

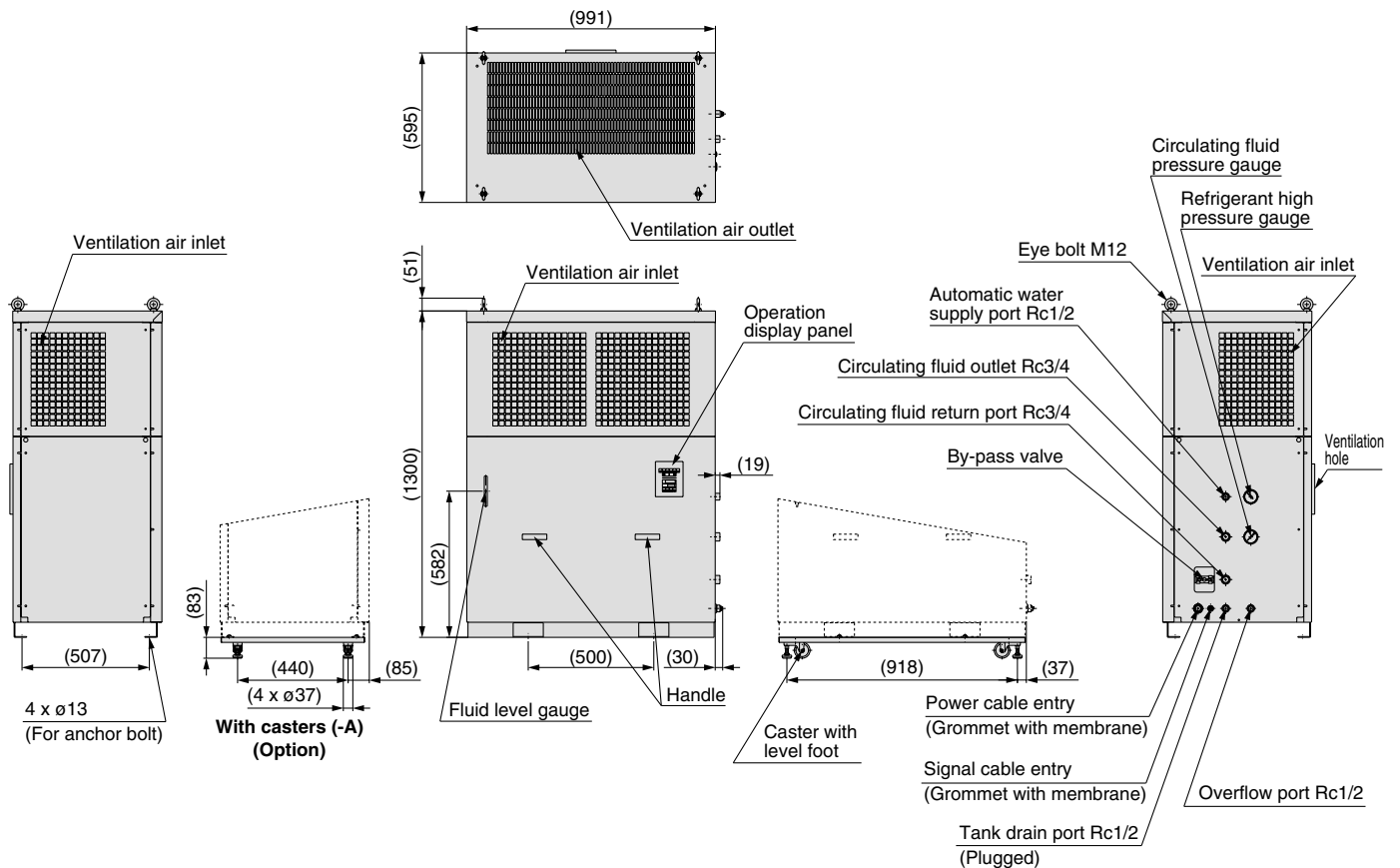

**Dimensions: Water-Cooled Refrigeration**

**HRG010-W (-A)**

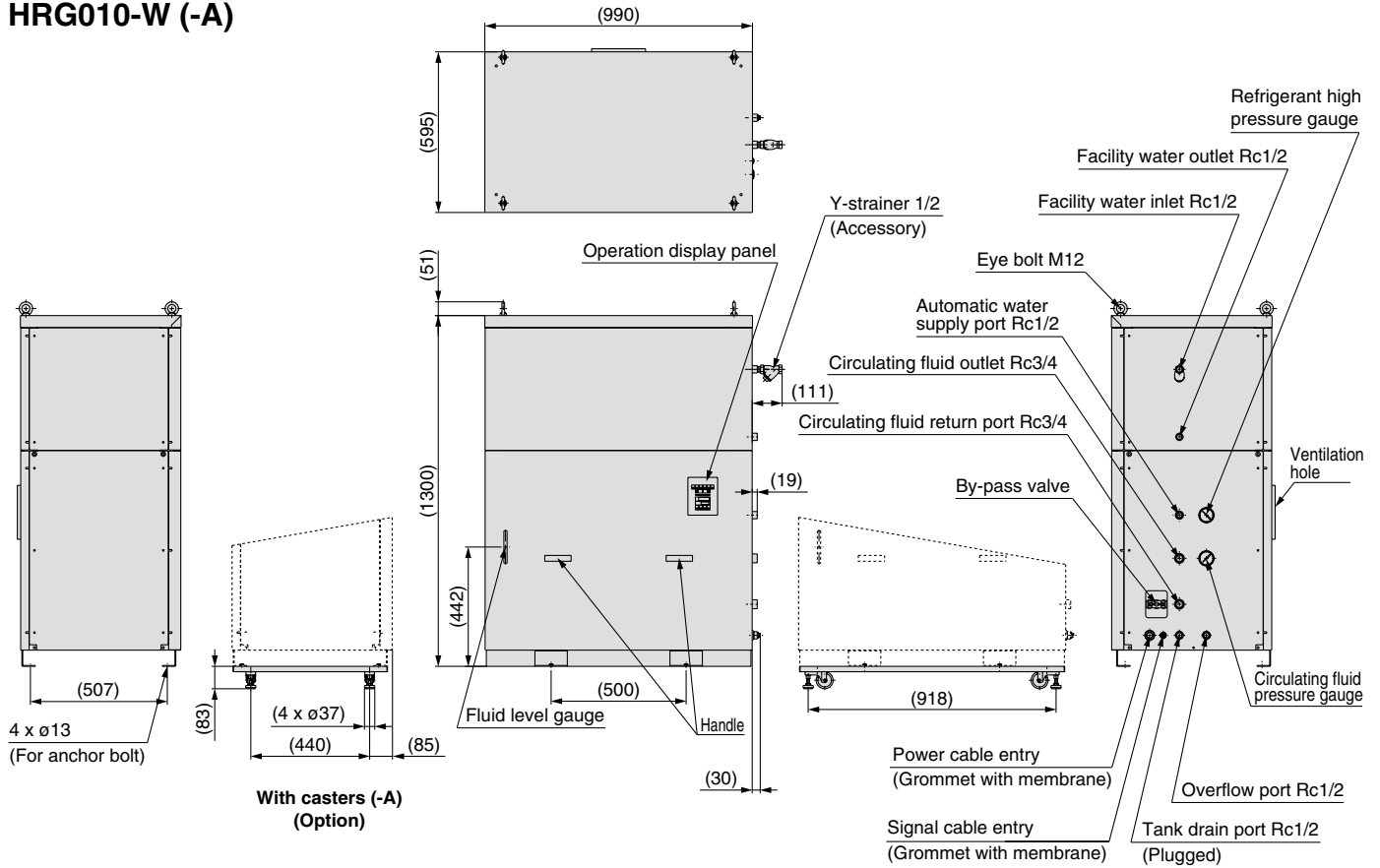

**HRG015-W (-A)**

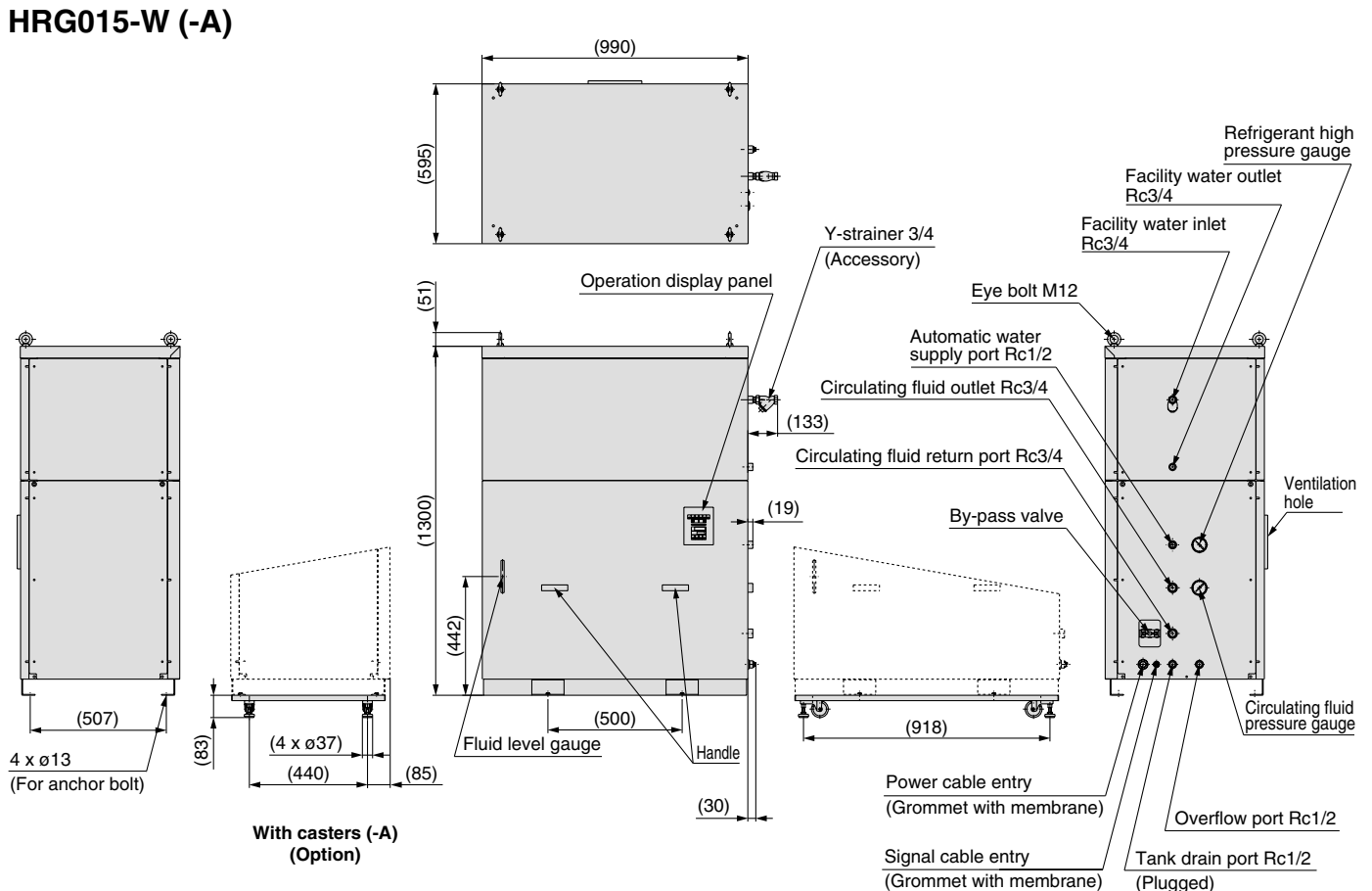

HRG
HRS
HRZ
HRZD
HRW
HEC
HEB
HED
Technical Data
Related Products

# Series HRG

## Piping Connection and Installation Dimensions

### HRG010, HRG015

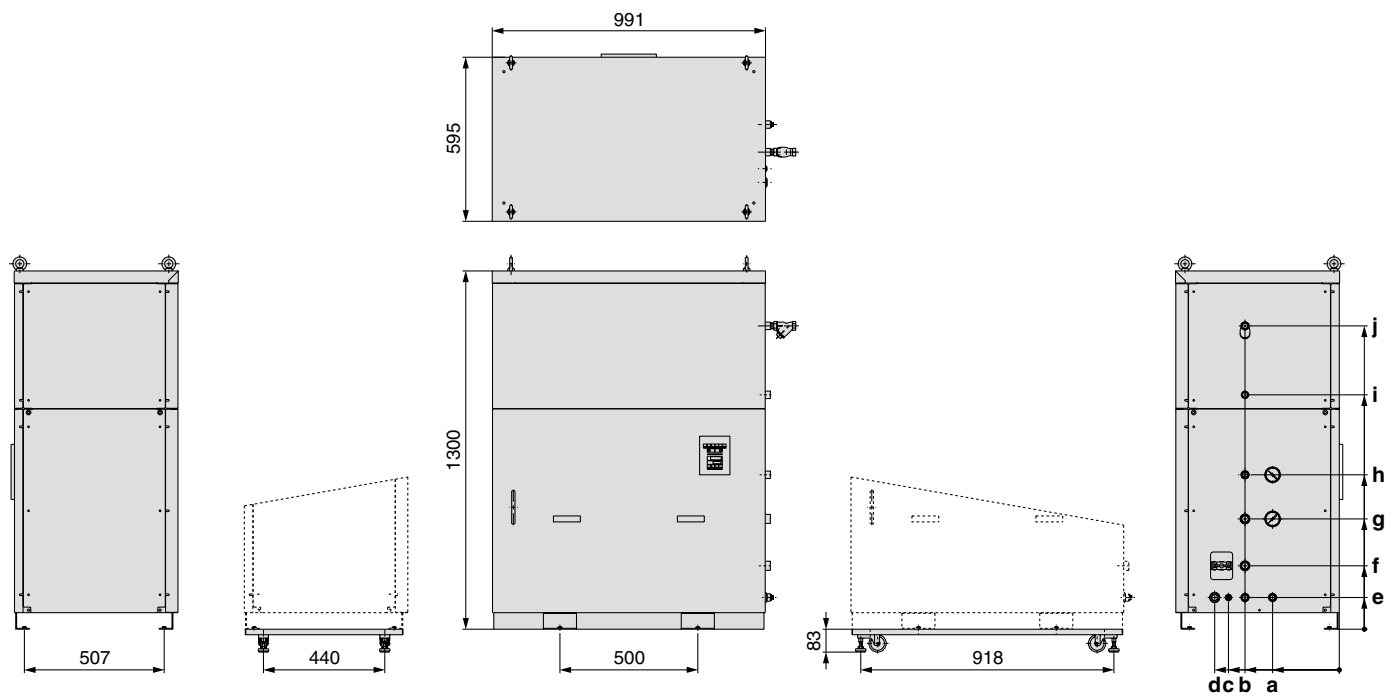

\* Example figure: HRG010-W

Model	a	b	c	d	e	f	g	h	i	j
HRG010-A	242	342	402	452	115	230	400	560	—	—
HRG010-W	242	342	402	452	115	230	400	560	850	1100
HRG015-A	242	342	402	452	115	230	400	560	—	—
HRG015-W	242	342	402	452	115	230	400	560	850	1100

(mm)

## Operation Display Panel

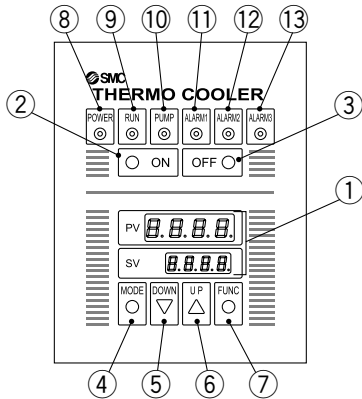

No.	Description	Function	
		HRG010, HRG015	
①	7-segment display screen	PV	Displays the current temperature of the circulating fluid outlet.
		SV	Displays the set temperature of the circulating fluid outlet.
②	[ON] switch	Starts the operation.	
③	[OFF] switch	Stops the operation.	
④	[MODE] key <sup>Note 1)</sup>	Changes the display between the temperature and control value <sup>Note 1)</sup> .	
⑤	[DOWN] key	Reduces the set temperature of the circulating fluid outlet.	
⑥	[UP] key	Increases the set temperature of the circulating fluid outlet.	
⑦	[FUNC] key <sup>Note 2)</sup>	Activates functions <sup>Note 2)</sup> that have been set.	
⑧	[POWER] indicator	Lights up when the power is being supplied to the unit.	
⑨	[RUN] indicator	Lights up when the unit is running.	
⑩	[PUMP] indicator	Lights up when the pump is running independently, or when the main unit is running.	
⑪	[ALARM] indicator, [ALARM1] indicator	Lights up when ALARM 1 is active.	
⑫	[ALARM2] indicator	Lights up when ALARM 2 is active.	
⑬	[ALARM3] indicator	Lights up when ALARM 3 is active.	

Note 1) All control values used in normal operation are displayed, but are locked and cannot be changed. It is not necessary to unlock these values except during maintenance.

Note 2) However, functions are not set. Pressing this key will have no effect.

## Alarm/Alarm Indicators and Explanation

The 6 basic temperature controller alarms are displayed on the operation display panel with alarm indicators (red LED). Operation stops if an alarm is active, assuring safety. When the source of the problem has been eliminated, the equipment must be restarted.

### Explanation of Alarms

Indicator	Alarm	Operation status	Main reason
<sup>Note 3)</sup> [ALARM1]	Prevention of reverse electrical current to the pump and compressor	Stop	Power supply to this unit is incorrect.
	Low level of fluid in tank	Stop	Level switch activated because fluid level in tank fell below LOW.
	Interrupted or abnormal facility water supply <sup>Note 1)</sup>	Stop	Pressure switch activated because inadequate heat dissipation caused refrigerant pressure to rise.
<sup>Note 4)</sup> [ALARM2]	Circulating fluid temperature abnormally high	Stop	Temperature sensor activated because circulating fluid temperature became too high.
	Overload of pump	Stop	Circulation pump overload relay activated.
<sup>Note 5)</sup> [ALARM3]	Overheating of fan motor <sup>Note 2)</sup>	Stop	Fan motor thermostat activated.
	Overload of compressor	Stop	Compressor overload relay activated.

Note 1) Only for water-cooled refrigeration (HRG□□□-W)

Note 2) Only for air-cooled refrigeration (HRG□□□-A)

Note 3) ALARM 1 lights up when power supply is turned on but operation has not commenced due to abnormal installation status: incorrect installation or inadequate preparation.

Note 4) ALARM 2 lights up if a water delivery circuit error occurs after operation has begun.

Note 5) ALARM 3 lights up if a refrigeration circuit error occurs after operation has begun.

## Contact Input/Output Function

The Thermo-cooler is equipped with terminals that allow remote start/stop, and enable output of an operation signal or abnormal status stop signal. These should be used for synchronizing startup and shutdown with your other equipment, or when adding new patrol lights or buzzers. However, the contact output volume is limited, so please add patrol lights and/or buzzers for special relays (for amplification) if they are necessary.

Item	Specifications	
	HRG010	HRG015
Connector type	M3 terminal block	
Remote operation signal input	Signal type	DC voltage input
	Input voltage range	24 VDC $\pm$ 5 V
	Input current	0.5 to 8 mA
	Terminal number <small>Note)</small>	24 (24 VDC), 25 (24 VCOM)
Alarm stop signal output	Signal type	Non-voltage contact output
	Contact capacity	250 VAC, 1 A (Resistance load)
	Terminal number <small>Note)</small>	28, 29
Operation signal output	Signal type	Non-voltage contact output
	Contact capacity	250 VAC, 1 A (Resistance load)
	Terminal number <small>Note)</small>	30, 31
Circuit diagram	<p>Note) For terminal numbers shown in the diagram, please refer to the terminal numbers for each type of signal listed in the table.</p>	

### Input/output signal connection location

Remove the front panel and connect a signal cable to the terminal block inside the electrical component enclosure.

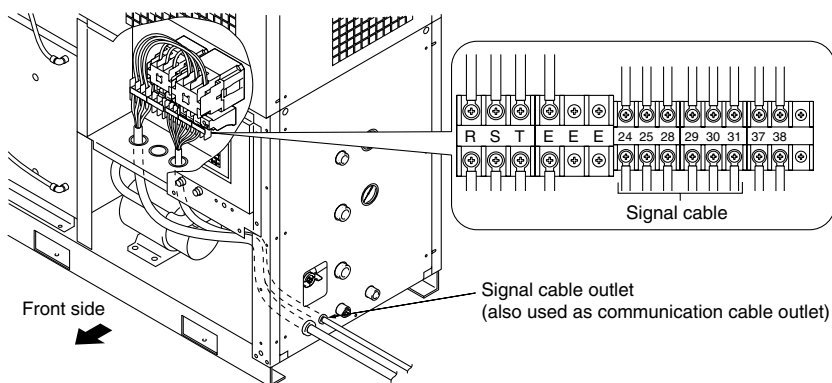

### Other Features

- Automatic water supply function (Built-in ball tap)**  
 The tank contains a built-in ball tap for water supply valve.  
 By installing a water supply connection, you can automatically keep the water level at its rated position (halfway between HI and LOW).
- Modified product with remote operation signal**  
 Remote operation is possible with a contact input. No need for DC power supply.  
\* HRG010, 015-□-□-X106
- Anti-freezing function**  
 This function detects the circulating fluid temperature. If the temperature approaches freezing point, e.g. in winter at night, the pump operates automatically and the heat generated by the pump warms the circulating fluid, preventing freezing.

# Series HRG Options

Note) Options have to be selected when ordering the Thermo-cooler. It is not possible to add them after purchasing the unit.

## A Option symbol With Casters

HRG  -  -A  
● With casters

The casters allow easy movement when delivering the equipment for installation or when altering the production area. A level foot may be used instead of a brake.

Applicable model	HRG010-□-A		HRG015-□-A	
Level foot height adjustment range (mm)	0 to 15			
Product weight (kg)	220	215	245	235
Product height (mm)	1383			

### Caster mounting location

Rotating casters with level foot at the four corners are attached to the caster bases.

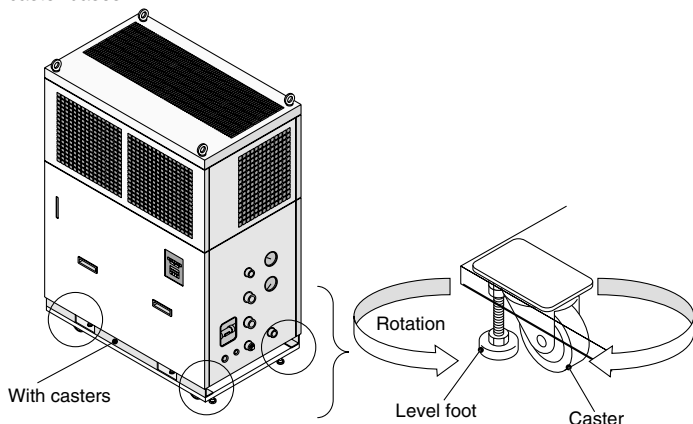

## B Option symbol With Earth Leakage Breaker

HRG  -  -B  
● With earth leakage breaker

In the event of a short circuit, overcurrent or overheating, the earth leakage breaker will automatically shut off the power supply. The power supply can be switched on or off easily from the main unit.

Applicable model	HRG010-□-B		HRG015-□-B	
Pole number	3			
Rated current sensitivity (mA)	30			
Rated shutdown current (A)	40		60	
Short circuit display method	Mechanical button			

### Breaker mounting location

Remove the front panel. The breaker is mounted inside the electrical component enclosure.

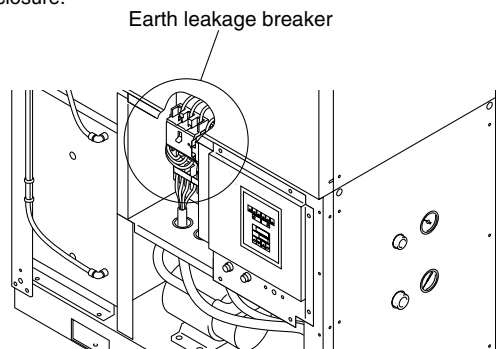

## C Option symbol With Communications Function (RS-485)

HRG  -  -C  
● With communications function (RS-485)

With a host PC programmed in accordance with your manufacturing processor method, the communications function allows you to set (write) or monitor (read) the circulating fluid temperature.

<Writing>

Circulating fluid temperature setting (SV)

<Readout>

Circulating fluid present temperature (PV)

Circulating fluid temperature setting (SV)

Applicable model	HRG010-□-C		HRG015-□-C	
Connector no.	37 (TRD+), 38 (TRD-)			
Connector type (on this product side)	M3 terminal block			
Standards	EIA RS-485 compliant			
Protocol	Special protocol: For details, refer to the Communications Specifications document.			

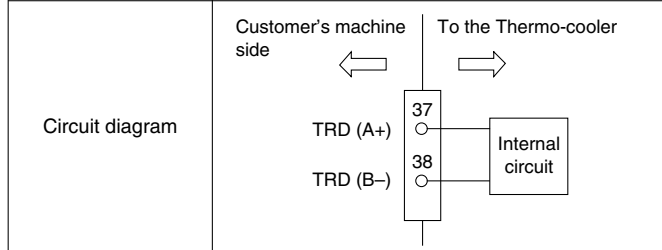

### Communication connection location

Remove the front panel, and connect your communication cable to the terminal block mounted inside the electrical component enclosure.

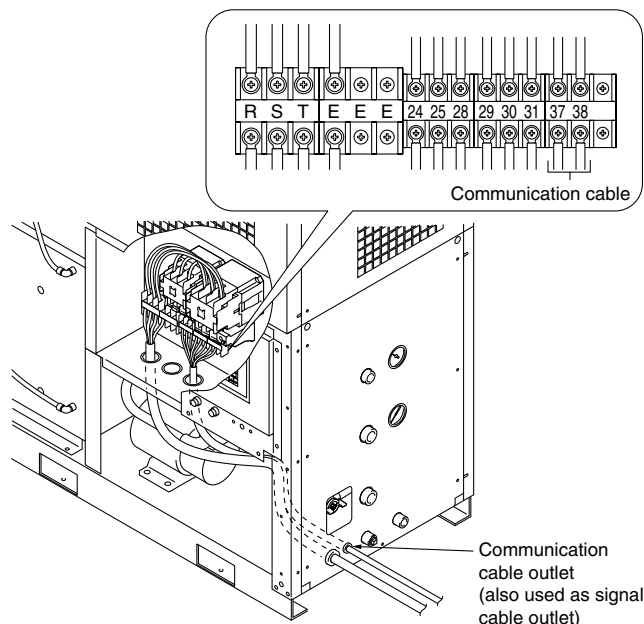

HRG

HRS

HRZ

HRZD

HRW

HEC

HEB

HED

Technical  
Data





Related  
Products



# Series HRG Optional Accessories

Note) Please order separately.  
Necessary to be fitted by  
the customer.

## Specifications

Description	Description	Specifications	Applicable Thermo-cooler
<b>Dustproof filter set</b> 	For preventing a decline in the performance of air-cooled refrigerated Thermo-coolers, even in a dusty atmosphere.	Maximum ambient temperature 40°C	HRG010-A□ to 015-A
<b>By-pass piping set</b> 	For preventing the pump from overloading at low flow rates when the maximum Thermo-cooler operating pressure of 0.5 MPa is exceeded.	Circulating fluid temperature range 5°C to 35°C	HRG010-A□ to 015-A HRG010-W□ to 015-W
<b>Separately installed power transformer</b> 	Power supply and voltage for those other than the standard.	Maximum ambient temperature 40°C (Relative humidity 85% or less)	HRG010-A□ to 015-A HRG010-W□ to 015-W
<b>Foundation bolt set</b> 	For fixing the Thermo-cooler to the foundation. Easy to use – just drive in the core rod.	Stainless steel	HRG010-A□ to 015-A HRG010-W□ to 015-W
<b>Piping adapter</b> 	For converting the thread type used in the connection port of the Thermo-cooler.	Copper alloy	HRG010-A□ to 015-A HRG010-W□ to 015-W

## How to Order

### [Dustproof filter set]

**HRG – FL**

#### • Applicable Thermo-cooler

Symbol	Applicable Thermo-cooler	Quantity per set
<b>010</b>	HRG010-A	1
<b>015</b>	HRG015-A	(Large) 1 (Small) 2

Note) Refer to page 23 for dimensions and page 25 for mounting.

### [By-pass piping set]

**HRG – BP**

#### • Applicable Thermo-cooler

Symbol	Applicable Thermo-cooler	Set pressure (Blow pressure)
<b>010</b>	HRG010-□	0.31 [MPa]
<b>015</b>	HRG015-□	0.32 [MPa]

Note) Refer to page 23 for dimensions and pages 25 for mounting and flow-rate characteristics.

### [Separately installed power transformer]

**IDF – TR**  –

#### • Volume

Symbol	Applicable Thermo-cooler	Volume
<b>14000</b>	HRG010-□	14 kVA
<b>18000</b>	HRG015-□	18 kVA

#### • Power supply voltage

Symbol	Inlet voltage	Outlet voltage	Type
<b>8</b>	220, 240, 380, 400, 415, 440 VAC (50/60 Hz)	200 VAC (50/60 Hz)	3-phase double

Note) Refer to page 24 for dimensions.

### [Foundation bolt set]

**IDF – AB**

#### • Size

Symbol	Applicable Thermo-cooler	Material	Quantity per set
<b>501</b>	HRG010-□ HRG015-□	Stainless steel	4

Note) Refer to page 24 for dimensions.

### [Piping adapter]

**IDF – AP**

#### • Size

Symbol	Applicable Thermo-cooler	Thread type and port size Male side <b>A</b> Female side <b>B</b>	Material	Quantity per set
<b>603</b>	HRG010-□ HRG015-□	R3/4 NPT3/4	Copper alloy	2

Note) Refer to page 24 for dimensions. Specify the quantity of units necessary for use with your piping system.

**Dimensions**

[Dustproof filter set]

**HRG-FL010**

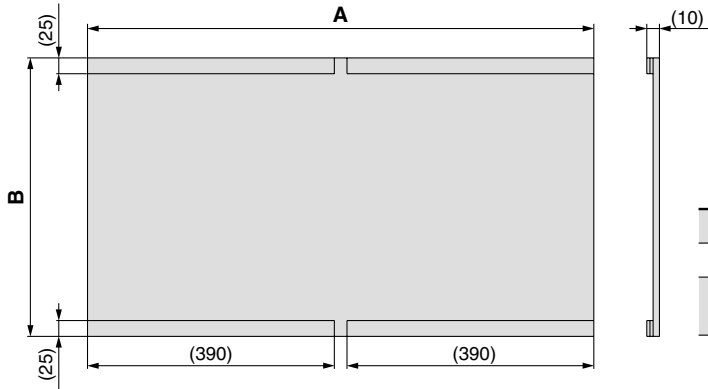

Part no.	A	B	C	Quantity per 1 set
<b>HRG-FL010</b>	880	440	10	1
<b>HRG-FL015</b>	(Large) 880 (Small) 330	(Large) 440 (Small) 440	(Large) 10 (Small) 10	(Large) 1 (Small) 2

(mm)

**HRG-FL015**

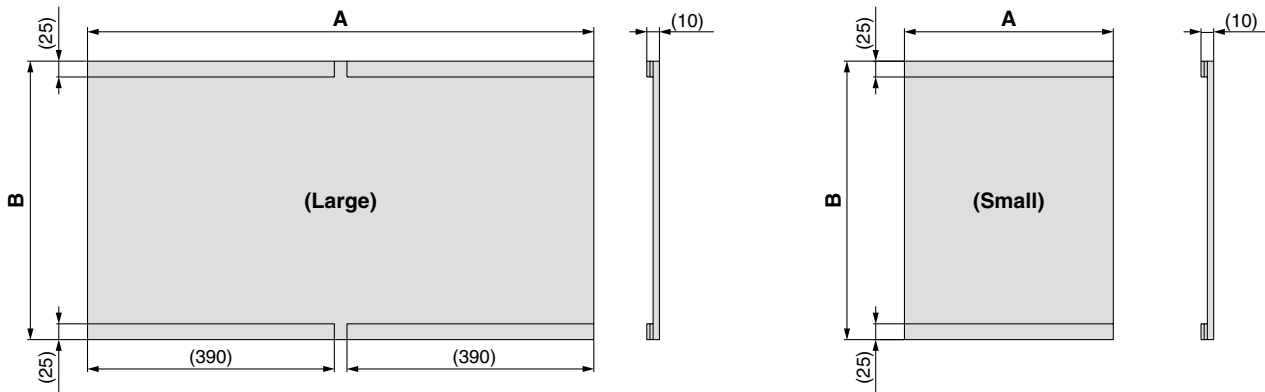

[By-pass piping set]

**HRG-BP010**

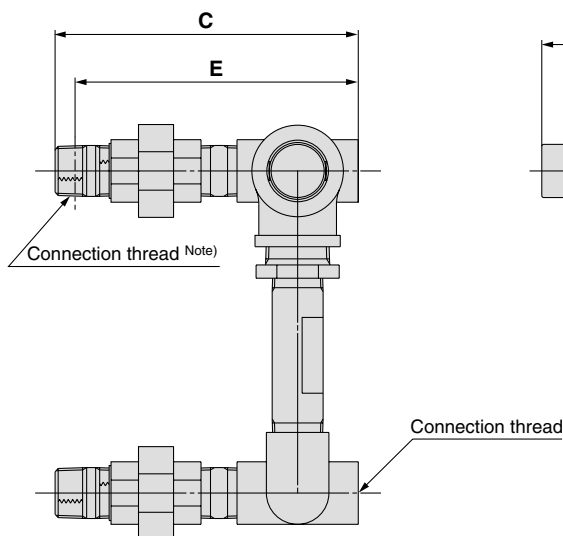

**HRG-BP015**

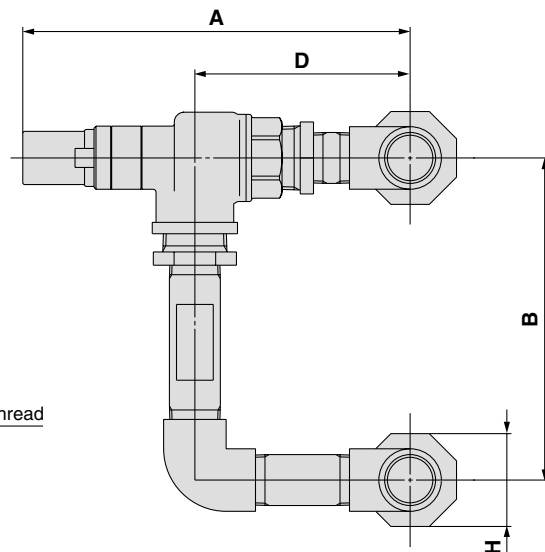

Part no.	Connection thread R, Rc	A	B	C	D	E	H (Width across flats)	Weight (kg)
<b>HRG-BP010</b>	3/4	206	170	150	114	138	49	2.6
<b>HRG-BP015</b>	3/4	236	170	150	122	138	49	3.2

(mm)

Note) The connection thread of the nipple comes with PTFE seal tape.

<b>HRG</b>
<b>HRS</b>
<b>HRZ</b>
<b>HRZD</b>
<b>HRW</b>
<b>HEC</b>
<b>HEB</b>
<b>HED</b>
<b>Technical Data</b>
<b>Related Products</b>

# Series HRG

## Dimensions

[Separately installed power transformer]

### Specifications

Transformer part no.	Applicable Thermo-cooler	Volume	Type	Inlet voltage	Outlet voltage
<b>IDF-TR14000-8</b>	HRG010-□	14 kVA	3-phase double	220, 240, 380, 400, 415, 440 VAC (50/60 Hz)	200 VAC (50/60 Hz)
<b>IDF-TR18000-8</b>	HRG015-□	18 kVA			

### IDF-TR-□-8

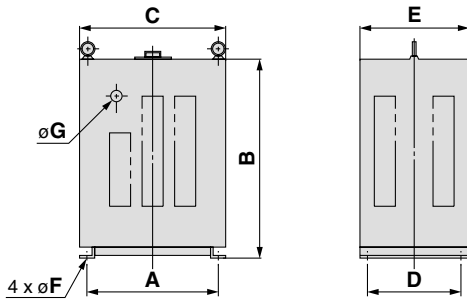

Transformer part no.	A	B	C	D	E	F	G	Weight (kg)
<b>IDF-TR14000-8</b>	400	650	450	300	350	13	40	152
<b>IDF-TR18000-8</b>	400	650	450	300	350	13	40	179

### [Foundation bolt set]

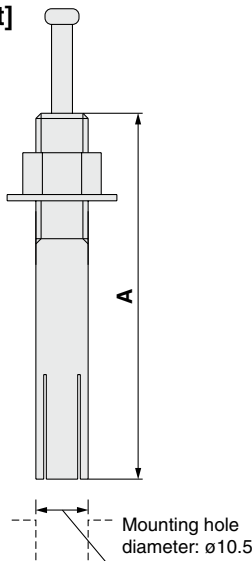

Part no.	Applicable Thermo-cooler	Nominal thread size	A	Quantity per set
<b>IDF-AB501</b>	HRG010-□ HRG015-□	M10	70	4

### [Piping adapter]

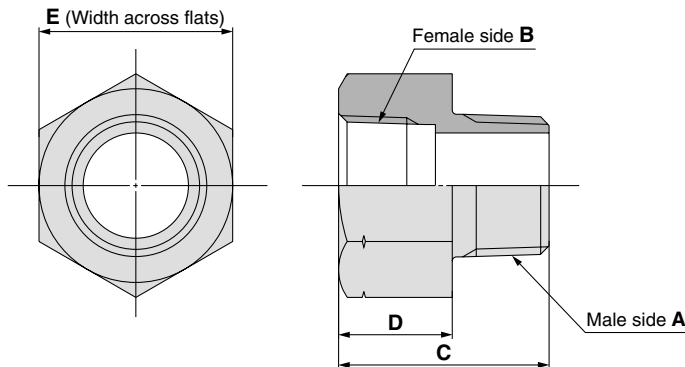

Part no.	Applicable Thermo-cooler	Thread type and port size		C	D	E	Quantity per set
		Male side A	Female side B				
<b>IDF-AP603</b>	HRG010-□ HRG015-□	R3/4	NPT3/4	43	23	32	2

## Mounting Example

Note) Please order separately. Necessary to be fitted by the customer.

### [Dustproof filter set]

- ① This dustproof filter is secured with hook-and-loop tape. This is sewed onto the male side of the surface fastener, and has adhesive tape backing for fixing to the female side.
- ② Remove the paper covering of the adhesive tape and affix the loop tape to the external panel of the ventilation hole on the Thermo-cooler.
- ③ Simply press the hook tape on to the loop tape to mount the dustproof filter.

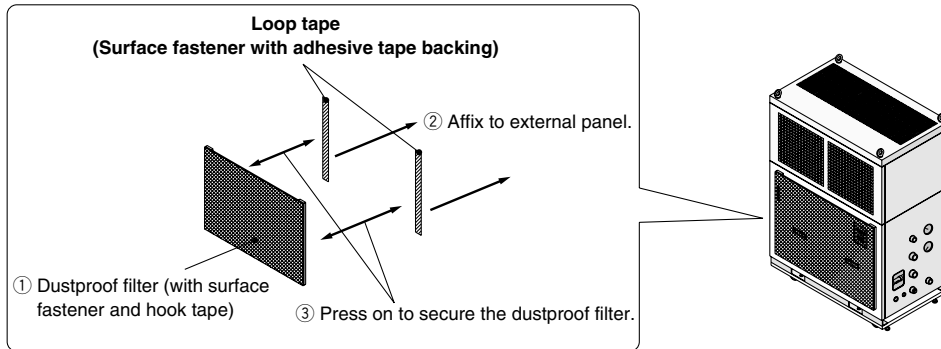

### [By-pass piping set]

- ① This set consists of a body with assembly of relief valve and union (female), along with a nipple, union (male) and union seal.
- ② To mount, screw the union (male) and nipple onto the circulating fluid outlet and circulating fluid return port of the Thermo-cooler.
- ③ Next, place the union seal between the union (male) and union (female) of the body, and gently tighten screw on tentatively (manually), in the appropriate mounting direction for the model used (refer to Operation Manual), paying attention to the direction of flow of the body (relief valve).
- ④ Finally, tightly fasten the union (female) of the body to the union (male) tightly. Note)

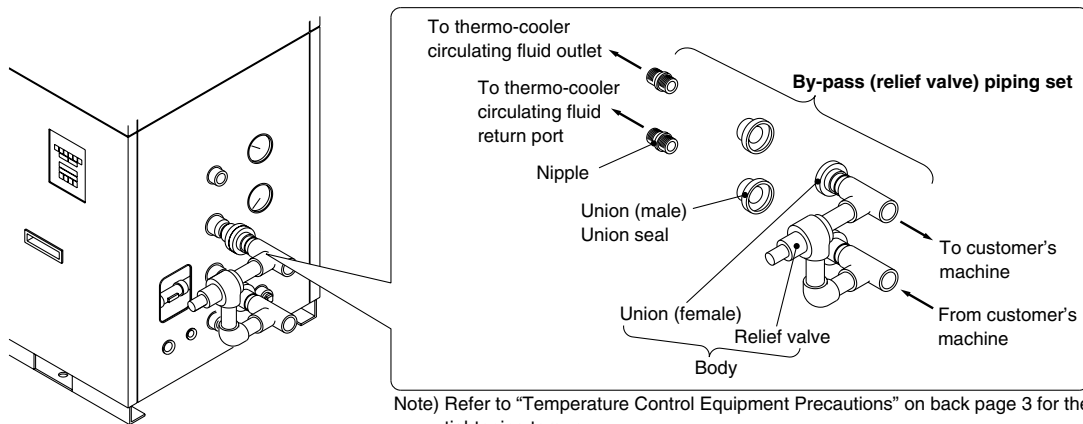

Note) Refer to "Temperature Control Equipment Precautions" on back page 3 for the nipple tightening torque.  
Refer to "Series HRG, Specific Product Precautions" on page 28 for the female union tightening torque.

### [Pump capacity for each Thermo-cooler after mounting the by-pass piping set]

#### HRG010-□ (After mounting HRG-BP010)

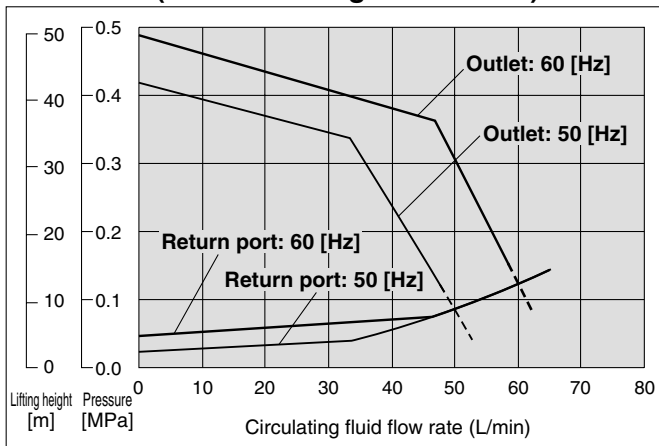

#### HRG015-□ (After mounting HRG-BP015)

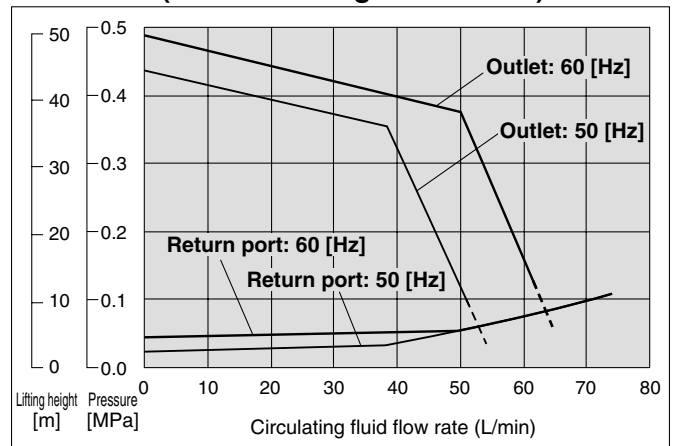



# Series HRG Specific Product Precautions 1

Be sure to read this before handling.

Refer to back page 1 for Safety Instructions and back pages 2 to 5 for Temperature Control Equipment Precautions.

## Design

### Warning

#### 1. This catalog shows the specifications of a single unit.

1. Confirm the specifications of the single unit (contents of this catalog) and thoroughly consider the adaptability between the customer's system and this unit.
2. Although the protection circuit as a single unit is installed, prepare a drain pan, water leakage sensor, discharge air facility, and emergency stop equipment, depending on the customer's operating condition. Also, the customer is requested to carry out the safety design for the whole system.

#### 2. When attempting to cool areas that are open to the atmosphere (tanks, pipes), plan your piping system accordingly.

When cooling open-air external tanks, arrange the piping so that there are coil pipes for cooling inside the tanks, and to carry back the entire flow volume of circulating fluid that is released.

## Selection

### Warning

#### 1. Model selection

For selecting a model of Thermo-cooler, it is required to know the heat generation amount of a customer's machine.

Obtain the heat generation amount, referring to the model selection example on pages 8 and 9 before selecting a model.

#### 2. Indication of model number

Select the cooling method and temperature stability depending on the customer's application.

## Handling

### Warning

#### 1. Thoroughly read the Operation Manual.

Read the Operation Manual completely before operation, and keep this manual available whenever necessary.

## Operating Environment/Storage Environment

### Warning

#### 1. Do not use in the following environment because it will lead to a breakdown.

1. Environment like written in "Temperature Control Equipment Precautions".
2. Locations where spatter will adhere to when welding.
3. Locations where it is likely that the leakage of flammable gas may occur.
4. Locations having a large quantity of dust.

If it is necessary to use the unit in an environment where there is a risk of the fin portion of the air-cooled condenser becoming clogged, please use the dustproof filter set (sold separately).

#### 2. Install in an environment where the unit will not come into direct contact with rain or snow.

(HRG010/015)

These models are built to rainproof enclosure IPx3, but are not completely waterproof to rain, etc. (as with IPx4 or higher).

To prolong the lifespan of this equipment, we recommend installation under an awning or other shelter.

## Operating Environment/Storage Environment

### Warning

#### 3. Conduct ventilation and cooling to discharge heat.

(Air-cooled refrigeration)

The heat which is cooled down through air-cooled condenser is discharged. When using in a room which is shut tightly, ambient temperature will exceed the specification range stipulated in this catalog, which will activate the safety detector and stop the operation.

In order to avoid this situation, discharge the heat outside of a room by ventilation or cooling facilities.

## Circulating Fluid

### Caution

#### 1. Avoid oil or other foreign objects entering the circulating fluid.

#### 2. Use an ethylene glycol aqueous solution that does not contain additives such as preservatives.

#### 3. When using ethylene glycol aqueous solution, maintain a maximum concentration of 15%.

Overly high concentrations can overload the pump, and cause safety protection devices to commence operation, stopping the operation of the unit.

Low concentrations, however, can lead to freezing at cold temperatures and cause the Thermo-cooler to break down.

#### 4. When using clear water as a circulating fluid, use water that conforms to the appropriate water quality standards.

Use water that conforms to the standards shown in the table below (including water used for dilution of ethylene glycol aqueous solution).

### Clear Water (as Circulating Fluid) Quality Standards

The Japan Refrigeration and Air Conditioning Industry Association

JRA GL-02-1994 "Cooling water system – Circulation type – Make-up water"

	Item	Unit	Standard value	Influence	
				Corrosion	Scale generation
Standard item	pH (at 25°C)	—	6.0 to 8.0	○	○
	Electrical conductivity (25°C)	[μS/cm]	100* to 300*	○	○
	Chloride ion (Cl <sup>-</sup> )	[mg/L]	50 or less	○	
	Sulfuric acid ion (SO <sub>4</sub> <sup>2-</sup> )	[mg/L]	50 or less	○	
	Acid consumption amount (at pH4.8)	[mg/L]	50 or less		○
	Total hardness	[mg/L]	70 or less		○
	Calcium hardness (CaCO <sub>3</sub> )	[mg/L]	50 or less		○
Reference item	Ionic state silica (SiO <sub>2</sub> )	[mg/L]	30 or less		○
	Iron (Fe)	[mg/L]	0.3 or less	○	○
	Copper (Cu)	[mg/L]	0.1 or less	○	
	Sulfide ion (S <sub>2</sub> <sup>-</sup> )	[mg/L]	Should not be detected.	○	
	Ammonium ion (NH <sub>4</sub> <sup>+</sup> )	[mg/L]	0.1 or less	○	
	Residual chlorine (Cl)	[mg/L]	0.3 or less	○	
	Free carbon (CO <sub>2</sub> )	[mg/L]	4.0 or less	○	

\* In the case of [MΩ·cm], it will be 0.003 to 0.01.

○: Factors that have an effect on corrosion or scale generation.

• Even if the water quality standards are met, complete prevention of corrosion is not guaranteed.

#### 5. It is possible to use or supply the unit with deionized water, but it is not possible to maintain specific resistance.

When using deionized water, make sure to supply water with an electrical conductivity of 1 μS/cm or more. (In case of electrical resistivity, it should be 1 MΩ·cm or less.) However, it is not possible to maintain electrolyte concentration, as elements of the parts coming into contact with fluid may dissolve.



# Series HRG Specific Product Precautions 2

Be sure to read this before handling.

Refer to back page 1 for Safety Instructions and back pages 2 to 5 for Temperature Control Equipment Precautions.

## Transportation/Transfer/Movement

### Warning

#### 1. Transportation by forklift

1. A licensed driver should drive the forklift.
2. The proper place to insert the tines of the forklift differs depending on the model of cooler. Check the Operation Manual to confirm, and be sure to drive the fork in far enough for it to come out the other side.
3. Be careful not to bump the fork to the cover panel or piping ports.

#### 2. Hanging transportation

1. Crane manipulation and slinging work should be done by an eligible person.
2. Do not grip the piping on the right side or the handles of the panel.
3. When hanging by the eye bolts, be sure to use a 4-point hanging method. For the hanging angle, use caution regarding the position of the center of gravity and hold it within 60°.

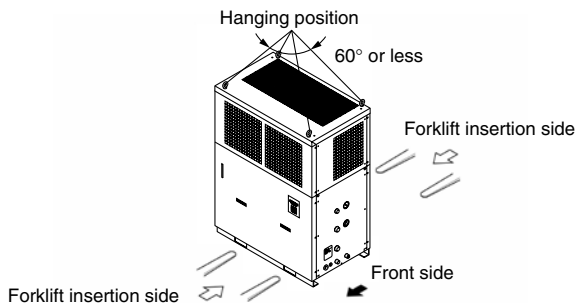

#### (When using optional casters HRG□□□□-□-**A**)

#### 1. Transportation by casters

1. This product is heavy and should be moved by at least two people.
2. Do not grip the piping port on the right side or the handles of the panel.
3. When transporting using a forklift, be sure not to let it hit the casters or adjusters, and drive the fork all the way through until it comes out the other side.

## Mounting/Installation

### Warning

1. Do not place heavy objects on top of this propiping, or step on it.  
The external panel can be deformed and danger can result.

2. Do not directly touch the edge of the external panel when removing and installing it.  
It may cause injury. Be sure to wear protective gloves.

(When using optional casters HRG□□□□-□-**A**)

3. Lower the level foot and do not move.

Be sure to lower all four level foot to the level of the floor.

### Caution

1. Install on a rigid floor which can withstand this product's weight.

2. Secure with bolts, anchor bolts, etc.

Fasteners such as bolts or anchor bolts should be tighten with the recommended torque shown below.

#### Fixing Thread Tightening Torque

Connection thread	Applicable tightening torque N·m
M5	3
M6	5.2
M8	12.5
M10	24.5
M12	42

#### (When using optional accessories/dustproof filter set)

1. Use the attached surface fastener (with adhesive tape) to affix the dustproof filter to the panel of the Thermo-cooler.

2. Mounting the filter will create a certain amount of resistance to ventilation that will reduce the volume of airflow.

For this reason, be sure to keep the ambient temperature at 40°C or less.

3. Depending on the installation height of the Thermo-cooler and/or the cooled substrates, circulating fluid may overflow from the tank lid or overflow outlet.

In particular, avoid overflow from the lid of the built-in tank by installing with a height difference of 10 m or less.

Be sure to pipe the overflow outlet to a wastewater collection pit, etc.

HRG

HRS

HRZ

HRZD

HRW

HEC

HEB

HED

Technical  
Data

Related  
Products



# Series HRG Specific Product Precautions 3

Be sure to read this before handling.

Refer to back page 1 for Safety Instructions and back pages 2 to 5 for Temperature Control Equipment Precautions.

## Piping

### ⚠ Caution

1. Regarding the circulating fluid pipings, consider carefully the suitability for shutoff pressure, temperature and circulating fluid.

If the operating performance is not sufficient, the pipings may burst during operation.

2. For the circulating fluid pipings, use clean pipings which have no dust, piping debris or other foreign objects inside the pipings, and blow with air prior to undertaking any piping works.

If piping debris or other foreign objects remain inside the circulating fluid circuit, it can result in blockage, insufficient cooling or damage to the pump impeller.

3. Select the piping port size which can exceed the rated flow.

For the rated flow, refer to the pump capacity table.

4. When tightening at the circulating fluid inlets and outlets, tank drain port or overflow outlet of this product, use a pipe wrench to clamp the connection ports.

5. For the circulating fluid piping connection, install a drain pan and wastewater collection pit just in case the circulating fluid may leak.

6. While cleaning the inside of the tank, attach a valve to the tank drain outlet to drain the circulating fluid (clear water).

7. This product series consists of circulating fluid temperature controllers with built-in tanks.

Do not install equipment on your system side such as pumps that forcibly return the circulating fluid to the unit. Also, if you attach an external tank that is open to the air, it may become impossible to circulate the circulating fluid. Proceed with caution.

#### (Water-cooled refrigeration HRG□□□-W-□)

1. When tightening at the facility water inlets and outlets of this product, use a pipe wrench to clamp the connection ports.

2. Install by-pass piping.

This product has a built-in water control valve, so when the refrigeration circuit is stopped, facility water does not flow out in order to save energy.

For this reason, by-pass piping is necessary for conducting maintenance of your facility water equipment, so be sure to install it.

3. When tightening at the water supply ports of this product, use a pipe wrench to clamp these ports.

This product has a built-in ball (float) tap. If you attach it to the faucet of a sink, etc. it will automatically supply water to the rated fluid level of the tank (halfway between HIGH and LOW.)

4. Supply water at a pressure of 0.5 MPa or less.

If the water supply pressure is too high, the pipes may burst during use. Proceed with caution.

(When using optional accessories/by-pass piping set)

1. In order to prevent foreign objects from entering during shipment, a polyethylene cap is attached to the inlets and outlets.

Remove these caps before piping.

2. Pay attention to the flow direction of the relief valve.

Refer to the mounting example shown in the separate operating manual for the by-pass piping set when mounting.

3. Tighten to the applicable torque shown below when tightening the cap nut (female) of the union.

#### Union (Female) Tightening Torque

Nominal size	Applicable tightening torque N·m
Rc1/2	64 to 125
Rc3/4	106 to 208

## Electrical Wiring

### ⚠ Warning

1. Never change the set value of the safety instrument.

If the set value is changed, it will likely cause a breakdown or cause the product to catch on fire.

2. Before wiring, be sure to cut the power supply.

Never perform any job while the product is energized.

3. When connecting the power, confirm the phase sequence (R, S, T) of the three-phase AC power supply.

An incorrect phase sequence will cause the anti-reversal safety protection device to be activated, and the unit will fail to operate. If this occurs, switch the two wires to the correct phase sequence.

4. Secure the cable so that its force, etc. is not applied to the terminal connector parts.

When the connection or attachment is incomplete, it will likely lead to an electrical shock, a fire, etc.

5. Grounding should never be connected to a water line, gas line or lightning rod.

6. Multiple wiring is dangerous because it will lead to heat generation or cause a fire.

### ⚠ Caution

1. Power supply, signal cable and connecting terminal should be prepared by the customer.

2. In the event of wiring the signal for operation/stop commands (remote control), use caution regarding the correct polarity (+, -) of 24 VDC.

(When using the HRG□□□-□-C with optional communications function)

1. Communication cables and adapters should be prepared by the customer.

Prepare parts that conform to the connector specifications of your host computer.

2. Pay attention to the polarity (TRD+, TRD-) when connecting communication cables.



# Series HRG Specific Product Precautions 4

Be sure to read this before handling.

Refer to back page 1 for Safety Instructions and back pages 2 to 5 for Temperature Control Equipment Precautions.

## Facility Water Supply

### Warning

(Water-cooled refrigeration HRG□□□-W-□)

#### 1. Before startup, be sure to open the valve of your facility water equipment.

Prepare before startup, so that facility water can flow when the fitted water control valve (facility water control valve) opens during operation.

#### 2. Supply pressure of 0.5 MPa or less.

If the supply pressure is high, it will cause water leakage.

#### 3. Be sure to prepare your utilities so that the pressure of the Thermo-cooler facility water outlet is at 0 MPa (atmospheric pressure) or more.

If the facility water outlet pressure becomes negative, the internal facility water piping may collapse, and proper flow control of facility water will be impossible.

## Operation

### Warning

#### 1. Confirmation before operation

1. The fluid level of a tank should be within the specified range of "HIGH" and "LOW".

When exceeding the specified level, the circulating fluid will overflow.

2. Remove the air.

Conduct a trial operation, looking at the fluid level.

Since the fluid level will go down when the air is removed from a customer's piping system, supply water once again when the fluid level is reduced. When there is no reduction in the fluid level, the job of removing the air is completed.

3. Handling of by-pass valve

At the time this product is shipped from our factory, the by-pass valve is fully open.

Operation with it fully closed will cause the circulating fluid outlet pressure to increase high and it may safely stop in order to prevent the pump's operation from overloading.

When operating for the first time after installation, be sure to operate it with the by-pass valve fully open.

#### 2. Confirmation during operation

1. Adjust the by-pass valve.

Monitor the external piping, pressure gauge, or flow meter mounted on the equipment from the customer's side, in order to adjust the open angle of the by-pass valve, so that the required pressure or flow can be obtained.

2. Confirm the circulating fluid temperature.

The operating temperature range of the circulating fluid is between 5 and 35°C.

When the amount of heat generated from a customer's machine is greater than the product's capability, the circulating fluid temperature may exceed this range. Use caution regarding this matter.

#### 3. Emergency stop method

• When an abnormality is confirmed, stop the equipment immediately.

After pushing the (OFF) switch, be sure to turn off the power supply breaker.

(When using optional accessories/by-pass piping set)

#### 1. Do not adjust or change the preset pressure.

When persons other than experts carry out adjustments, leakage can occur from the shaft seal of the adjustment screw. Proceed with caution.

## Operation

### Caution

#### 1. The temperature set value can be written to EEPROM, but only up to approx. 1 million times.

Especially when using communication function, save data with STOR before stoppage, and do not carry out frequent saving (STOR) of temporary setting values.

## Operation Restart Time

### Caution

#### 1. Wait five minutes or more before restarting operation after it has been stopped. If the operation is restarted within five minutes, the protection circuit may activate and the operation may not start properly.

## Protection Circuit

### Caution

#### 1. If operating in the below conditions, the protection circuit will activate and an operation may not be performed or will stop.

- Power supply voltage is not within the rated voltage range of  $\pm 10\%$ .
- The order of the 3-phase power supply, R, S, T is different.
- In case the water level inside the tank is reduced abnormally.
- Facility water is not supplied. (HRG□□□-W)
- Transfer pressure of the circulating fluid is too high.
- Circulating fluid temperature is too high.
- Compared to the cooling capacity, the heat generation amount of a customer's machine is too high.
- Ambient temperature is too high. (40°C or higher)
- Refrigerant pressure is too high.
- Ventilation hole is clogged with dust or dirt. (Especially HRG□□□-A)

## Maintenance

### Warning

#### 1. Do not operate the switch with wet hands or touch electrical parts. This will lead to an electrical shock.

#### 2. Do not splash water directly on this product for cleaning.

This will lead to an electrical shock or a fire.

#### 3. When the panel was removed for the purpose of inspection or cleaning, mount the panel after works were done.

If the panel is still open, or running the equipment with the panel removed, it may cause an injury or electric shocks.

#### 4. When cleaning the air-cooled condenser, do not touch the fin directly.

This may lead to injuries.

HRG

HRH

HRZ

HRZD

HRW

HEC

HEB

HED

Technical Data

Related Products





# Series HRG Specific Product Precautions 5

Be sure to read this before handling.

Refer to back page 1 for Safety Instructions and back pages 2 to 5 for Temperature Control Equipment Precautions.

## Maintenance

### Caution

#### <Periodical inspection every one month>

##### (Air-cooled refrigeration HRG□□□-A-□)

###### 1. Clean the ventilation hole.

If the fin portion of the air-cooled condenser becomes clogged with dust or debris, a decline in cooling performance can result. In order to avoid deforming or damaging the fin, clean it with a long-haired brush or air gun.

#### (When using optional accessories/dustproof filter set)

###### 1. Clean the dustproof filter.

To prevent dirt or clogging of the dustproof filter from leading to a decline in heat-releasing performance of the air-cooled condenser, clean or wash it regularly.

###### 2. Remove the filter from the Thermo-cooler before cleaning it.

Do not directly splash water on the filter to clean it while it is still attached to the Thermo-cooler. This can lead to electric shock or fires in the main unit of the Thermo-cooler.

#### <Periodical inspection every three months>

###### 1. Inspect the circulating fluid.

- When using clear water or deionized water
  - Replacement of clear water or deionized water  
Failure to replace the clear water or deionized water can lead to the development of bacteria or algae. Replace it regularly depending on your usage conditions.
  - Tank cleaning  
Consider whether dirt, slime or foreign objects may be present in the circulating fluid inside the tank, and carry out regular cleanings of the tank.
- When using ethylene glycol aqueous solution  
Use a concentration measurement device to confirm that the concentration does not exceed 15%.  
Dilute or add as needed to adjust the concentration.

###### 2. Check the water quality of facility water.

Regarding the water quality standards for facility water, refer to "Temperature Control Equipment Precautions".

#### <Periodical inspection every six months>

###### 1. Inspect the circulating fluid.

- Remove the panel and inspect if there is abnormal leakage from the pump's mechanical seal.
- Leakage amount of a mechanical seal  
Leakage of the mechanical seal cannot be completely avoided due to its construction (rotating machine). Although this amount of leakage is stipulated as 3 (cc/h) or less (reference value) according to the JIS standard, replace the mechanical seal when the amount of leakage is 0.3 (cc/h) or greater.  
Also, as a guide for periodically replacement, the operation hours is 6000 to 8000 hours. (normally 1 year)<sup>Note)</sup>

Note) In placing an order of mechanical seal set (service parts), inform us of the complete model number and the production lot number of the product in use.

#### <Periodical inspection during the winter season>

###### 1. Keep the pump operating.

- Keep the power supply running (POWER light on, RUN light off), and fully open the valves in the circulating fluid piping.

If the circulating fluid temperature falls below 3°C, the pump will start operating automatically. The heat generated by the pump operation will warm up the circulating fluid. When the temperature rises above 5°C, the pump will stop automatically. Consequently, the circulating fluid temperature is kept between 3°C and 5°C to avoid being frozen.

###### 2. Make water-removal arrangements beforehand.

In extremely cold weather conditions, the heat generated by the pump as described above may not be enough to prevent freezing.

If you expect these kind of conditions, remove the circulating fluid (especially clear water or deionized water) beforehand.

###### 3. Consult a professional.

For additional methods to prevent freezing (such as commercially available tape heaters, etc.), consult a professional for advice.