

Prepared		Product Specifications AN7580	Ref No.	A-1
Checked			Total Page	8
Approved			Page No.	1

Structure	Silicon Monolithic Bipolar IC
Appearance	SIL-12 Pins Plastic Package (FP-12S Power Type With Fin)
Application	Audio
Function	25W (6Ω) x 2ch BTL Power Amplifier Built-in Standby and Muting Features Incorporating Various Protection Circuits

Absolute Maximum Ratings					
No.	Item	Symbol	Ratings	Unit	Note
1	Storage Temperature	Tstg	-55 ~ +150	° C	
2	Operating Ambient Temperature	Topr	-25 ~ +75	° C	
3	Operating Ambient Pressure	Popr	1.013x10 ⁵ ±0.61x10 ⁵	Pa	
4	Operating Constant Acceleration	Gopr	9,810	m / s ²	
5	Operating Shock	Sopr	4,900	m / s ²	
6	Power Supply Voltage	Vcc	24	V	1
7	Power Supply Current	Icc	8.0	A	
8	Power Dissipation	PD	37.5	W	2

Operating Supply Voltage Range	Vcc	8.0 V ~ 20.0 V
--------------------------------	-----	----------------

Note: 1) Without input signal, Vcc is up to 27V
2) Ta = 75°C with infinite heatsink

Eff. Date	Eff. Date	Eff. Date	Eff. Date	
09-JUL-2001				

Prepared		Product Specifications AN7580	Ref No.	B-1
Checked			Total Page	8
Approved			Page No.	2

No.	Item	Symbol	Test Cct.	Condition	Limit			Unit	Note
					Min	Typ	Max		
1	Quiescent Circuit Current	I _{cq}	1	V _{in} =0mV	-	150	300	mA	
2	Output Noise Voltage	V _{no}	1	V _{in} =0mV, R _g =20kΩ	-	0.27	0.5	mV _{rms}	1
3	Voltage Gain	G _{vc}	1	V _{in} =20mV	38	40	42	dB	
4	Total Harmonic Distortion	THD	1	V _{in} =20mV	-	0.07	0.4	%	2
5	Maximum Output Power 1	P _{o1}	1	THD=10%	12	15	-	W	
6	Maximum Output Power 2	P _{o2}	1	V _{CC} =18V, R _L =6Ω, THD=10%	21.5	25	-	W	
7	Channel Balance	CB	1	V _{in} =20mV	-1	0	1	dB	
8	Channel Crosstalk	CT	1	V _{in} =20mV, R _g =20kΩ	55	70	-	dB	2
9	Output Offset Voltage	V _{off}	1	R _g =20kΩ	-350	0	350	mV	
10	Ripple Rejection	RR	1	V _r =1V _{rms} , f _r =120Hz, R _g =20kΩ	50	60	-	dB	1
11	Standby Current	I _{STB}	1	V _{in} =0mV	-	1	10	μA	
12	Muting Effects	MT	1	V _{in} =20mV	70	80	-	dB	2

Note : 1) With a filter band 20Hz ~20kHz (12 dB/OCT) used.

2) With a filter band 400Hz ~30kHz used.

Eff. Date	Eff. Date	Eff. Date	Eff. Date
09-JUL-2001			

Prepared		Product Specifications AN7580	Ref No.	C-1
Checked			Total Page	8
Approved			Page No.	3

Description of Test Circuits and Test Methods
[Test Circuit 1]

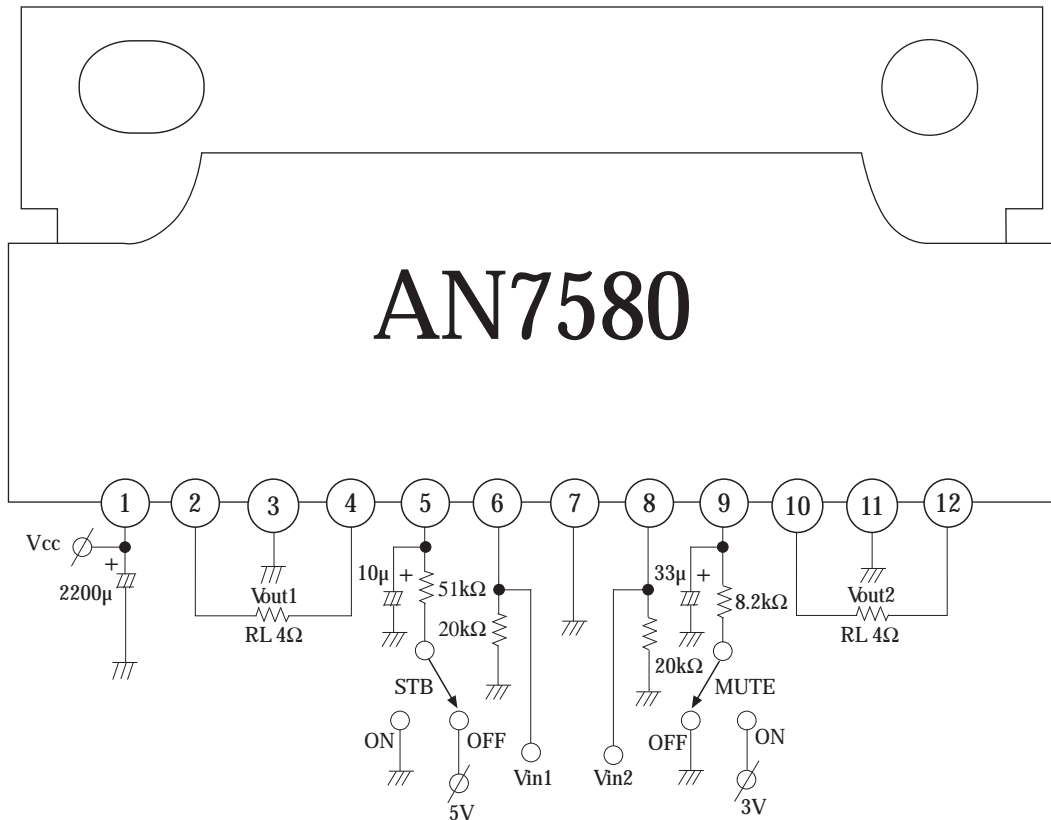

Note : * STB 'OFF' means 5V.
MUTE 'OFF' means 0V.

Eff. Date	Eff. Date	Eff. Date	Eff. Date
09-JUL-2001			

Prepared		Product Specifications AN7580	Ref No.	D-1
Checked			Total Page	8
Approved			Page No.	4

Circuit Function Block Diagram

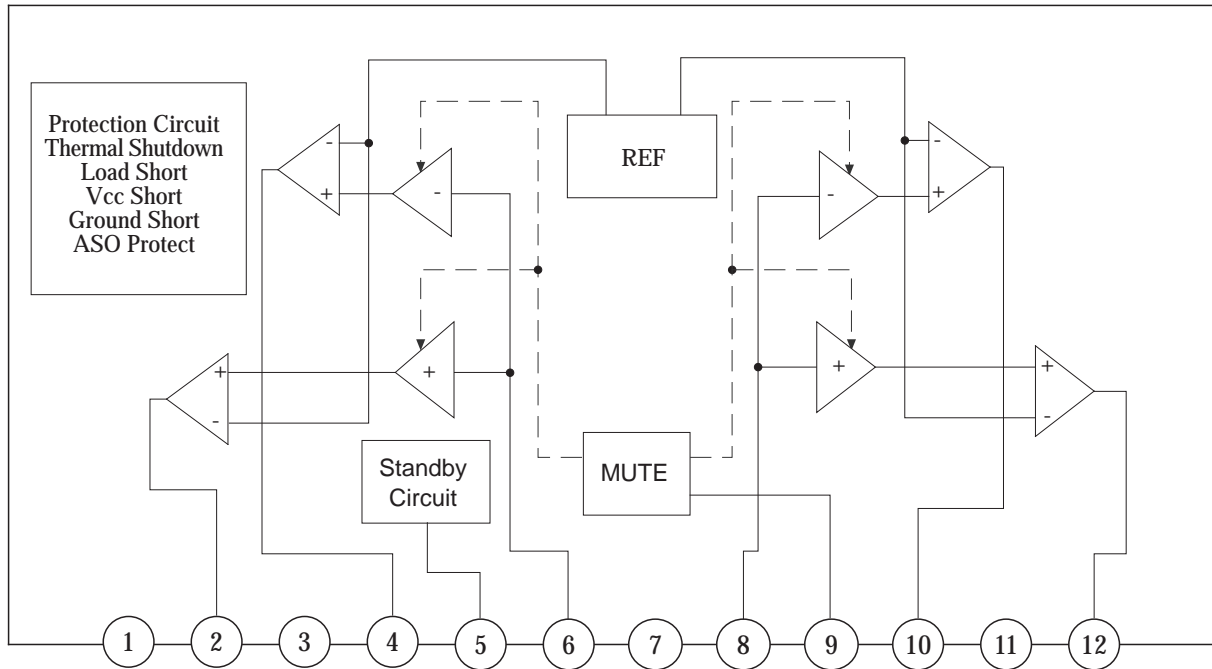

Pin Descriptions

Pin No.	Pin Descriptions	Pin No.	Pin Descriptions
1	Vcc	7	Pre GND
2	Ch1 +ve Phase Output	8	Ch2 Input
3	Ch1 Output GND	9	Mute
4	Ch1 -ve Phase Output	10	Ch2 -ve Phase Output
5	Standby	11	Ch2 Output GND
6	Ch1 Input	12	Ch2 +ve Phase Output

Eff. Date	Eff. Date	Eff. Date	Eff. Date
09-JUL-2001			

Prepared		Product Specifications AN7580	Ref No.	E
Checked			Total Page	8
Approved			Page No.	5

Package Name	FP-12S
--------------	--------

Unit : mm

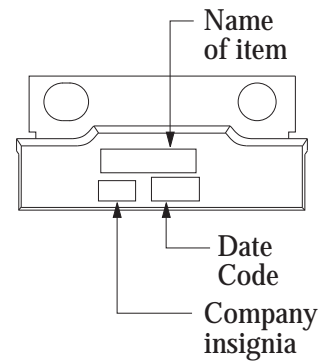
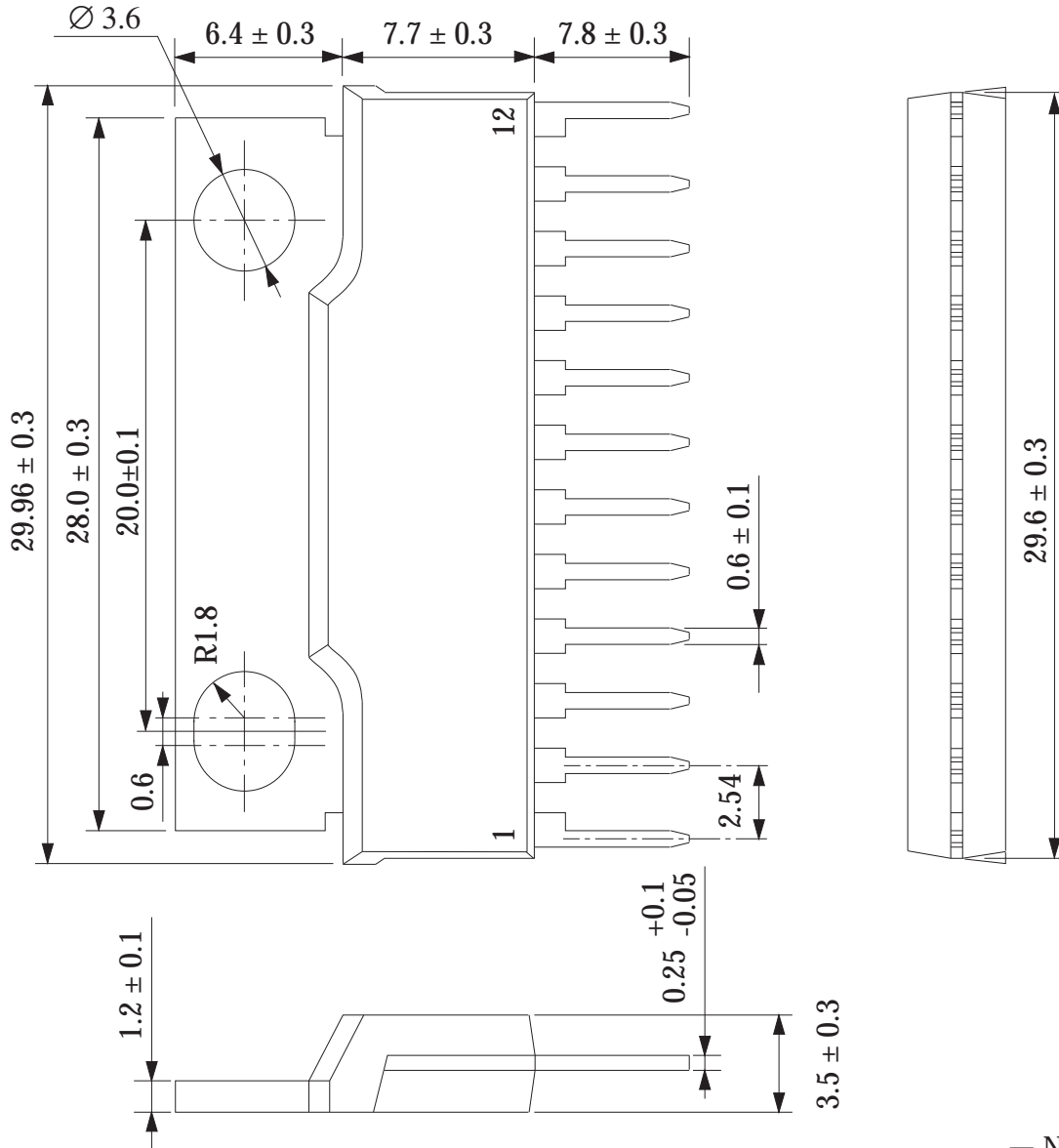

Eff. Date	Eff. Date	Eff. Date	Eff. Date
09-JUL-2001			

Prepared		Product Specifications AN7580	Ref No.	F-1
Checked			Total Page	8
Approved			Page No.	6

(Structure Description)

Chip surface passivation	SiN,	PSG,	Others ()	①	
Lead frame material	Fe group,	Cu group,	Others ()	②, ⑥	
Inner lead surface process	Ag plating,	Au plating,	Others ()	②	
Outer lead surface process	Solder plating,	Solder dip,	Others ()	⑥	
Chip mounting method	Ag paste,	Au-Si alloy,	Solder,	Others ()	③
Wire bonding method	Thermalsonic bonding,		Others ()	④	
Wire material, Diameter	Au,	Diameter 38 μm	Others ()	④	
Mold material	Epoxy,		Others ()	⑤	
Molding method	Transfer mold,	Multiplunger mold,	Others ()	⑤	
Fin material	Cu Group		Others ()	⑦	

Package FP-12S

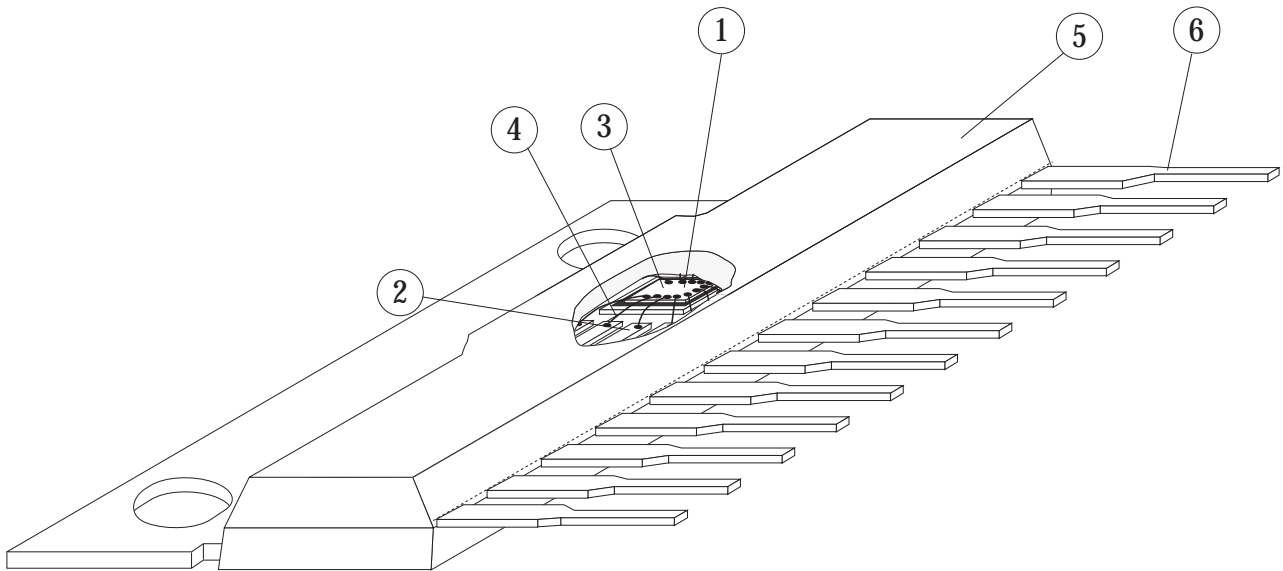

Eff. Date	Eff. Date	Eff. Date	Eff. Date	
09-JUL-2001				

Application Circuit

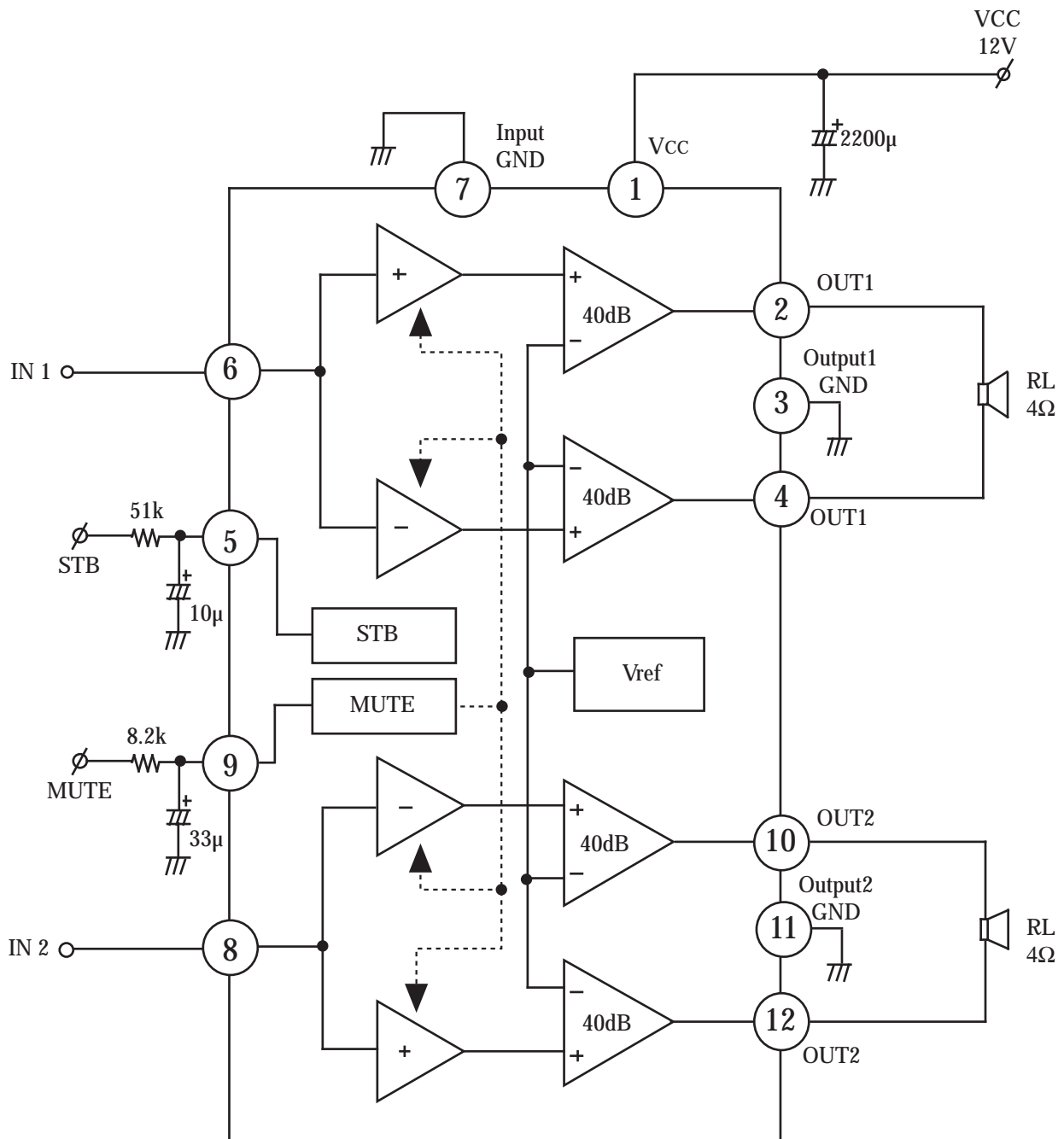

STB 'OFF'	5V
STB 'ON'	0V
Mute 'OFF'	0V
Mute 'ON'	3V

Eff. Date

Eff. Date

Eff. Date

Eff. Date

09-JUL-2001

Prepared		Product Specifications AN7580	Ref No.	G-2
Checked			Total Page	8
Approved			Page No.	8

PD - Ta Curves

- (1) $T_c = T_a$, 62.5W ($\theta_{j-c} = 2\text{ }^\circ\text{C/W}$)
 (2) 20.83W ($\theta_f = 4.0\text{ }^\circ\text{C/W}$)
 With a 100cm² X 3mm Al heat sink (black colour coated)
 or a 200cm² X 2mm Al heat sink (not lacquered)
- (3) 15.63W ($\theta_f = 6.0\text{ }^\circ\text{C/W}$)
 With a 100cm² X 2mm Al heat sink (not lacquered)
- (4) 3.0W at $T_a = 25^\circ\text{C}$ ($\theta_{j-a} = 42^\circ\text{C/W}$)
 Without heat sink

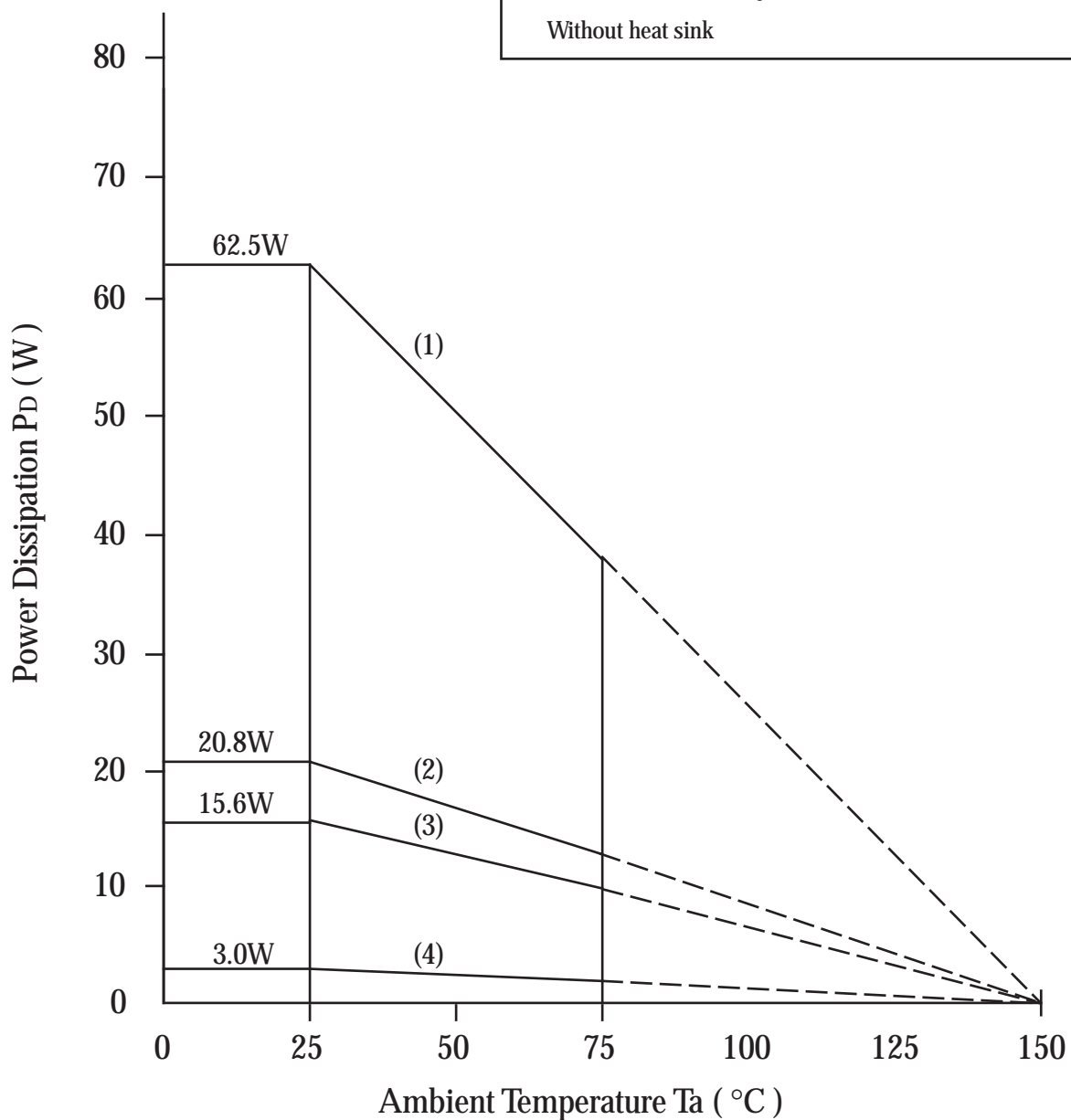

Eff. Date	Eff. Date	Eff. Date	Eff. Date
09-JUL-2001			