

**Space-saving Dual Output Signal Conditioners  
Mini-MW Series**

**CT TRANSMITTER**

(RMS sensing)

**Functions & Features**

- Converts alternating current from a current transformer into a standard process signal
- Minimum ripple
- Rerouted input signal does not pass through the base socket in order to protect it from melting caused by rush current of a motor
- CT Protector provided for open-circuit protection
- CE marking
- UL approval

**Typical Applications**

- Centralized monitoring and control of motors, pumps or heaters by DCS
- Monitoring power line and power supply current

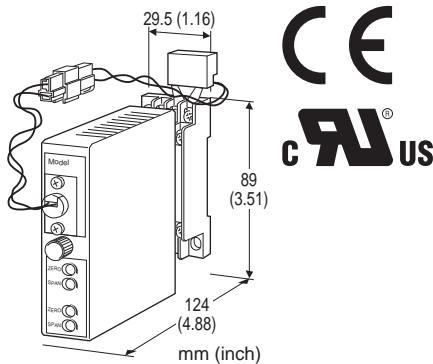

**MODEL: W2CE-[1][2][3]-[4][5]**

**ORDERING INFORMATION**

- Code number: W2CE-[1][2][3]-[4][5]
- Specify a code from below for each [1] through [5].  
(e.g. W2CE-5AA-M2/CE/Q)
- Special output ranges (For codes Z & 0)
  - Specify the specification for option code 'Q.'
- (e.g. /C01/S01)
- Note: If one of the outputs should be a current range, specify it for the Output 1 to allow a greater load.

**[1] INPUT**

**Current**

- 1: 0 - 1 A AC
- 5: 0 - 5 A AC

**[2] OUTPUT 1**

**Current**

- A: 4 - 20 mA DC (Load resistance 750 Ω max.)
- B: 2 - 10 mA DC (Load resistance 1500 Ω max.)
- C: 1 - 5 mA DC (Load resistance 3000 Ω max.)
- D: 0 - 20 mA DC (Load resistance 750 Ω max.)
- E: 0 - 16 mA DC (Load resistance 900 Ω max.)
- F: 0 - 10 mA DC (Load resistance 1500 Ω max.)
- G: 0 - 1 mA DC (Load resistance 15 kΩ max.)
- Z: Specify current (See OUTPUT SPECIFICATIONS)

**Voltage**

- 1: 0 - 10 mV DC (Load resistance 10 kΩ min.)
- 2: 0 - 100 mV DC (Load resistance 100 kΩ min.)
- 3: 0 - 1 V DC (Load resistance 1000 Ω min.)
- 4: 0 - 10 V DC (Load resistance 10 kΩ min.)
- 5: 0 - 5 V DC (Load resistance 5000 Ω min.)
- 6: 1 - 5 V DC (Load resistance 5000 Ω min.)
- 4W: -10 - +10 V DC (Load resistance 10 kΩ min.)
- 5W: -5 - +5 V DC (Load resistance 5000 Ω min.)
- 0: Specify voltage (See OUTPUT SPECIFICATIONS)

**[3] OUTPUT 2**

Y: None

**Current**

- A: 4 - 20 mA DC (Load resistance 350 Ω max.)
- B: 2 - 10 mA DC (Load resistance 700 Ω max.)
- C: 1 - 5 mA DC (Load resistance 1400 Ω max.)
- D: 0 - 20 mA DC (Load resistance 350 Ω max.)
- E: 0 - 16 mA DC (Load resistance 430 Ω max.)
- F: 0 - 10 mA DC (Load resistance 700 Ω max.)
- G: 0 - 1 mA DC (Load resistance 7000 Ω max.)
- Z: Specify current (See OUTPUT SPECIFICATIONS)

**Voltage**

Same range availability as Output 1

**[4] POWER INPUT**

**AC Power**

- M2: 100 - 240 V AC (Operational voltage range 85 - 264 V, 47 - 66 Hz)
- (90 - 264 V for UL)

**DC Power**

- R: 24 V DC (Operational voltage range 24 V ±10 %, ripple 10 %p-p max.)
- R2: 11 - 27 V DC (Operational voltage range 11 - 27 V, ripple 10 %p-p max.) (Select 'N' for 'Standards & Approvals' code.)
- P: 110 V DC (Operational voltage range 85 - 150 V, ripple 10 %p-p max.) (110 V ±10 % for UL)

**[5] OPTIONS (multiple selections)****Standards & Approvals (must be specified)**

/N: Without CE or UL

/CE: CE marking

/UL: UL approval, CE marking

**Other Options**

blank: none

/Q: Option other than the above (specify the specification)

(UL not available)

**SPECIFICATIONS OF OPTION: Q (multiple selections)****COATING (For the detail, refer to M-System's web site.)**

/C01: Silicone coating

/C02: Polyurethane coating

/C03: Rubber coating

**TERMINAL SCREW MATERIAL**

/S01: Stainless steel

**GENERAL SPECIFICATIONS****Construction:** Plug-in**Connection:** M3 screw terminals (torque 0.8 N·m)**Housing material:** Flame-resistant resin (black)**Isolation:** Input to output 1 to output 2 to power**Input waveform****RMS sensing:** Up to 15 % of 3rd harmonic content**Overrange output:** 0 to 120 % at 1 - 5 V**Zero adjustment:** -5 to +5 % (front)**Span adjustment:** 95 to 105 % (front)**INPUT SPECIFICATIONS****Frequency:** 50 or 60 Hz**Input burden:**

≤ 0.1 VA (input 0 - 1 A)

≤ 0.5 VA (input 0 - 5 A)

**Overload capacity:** 500 % of rating for 5 sec., 120 % continuous**Operational range:** 0 - 120 % of rating**OUTPUT SPECIFICATIONS**■ **DC Current:** 0 - 20 mA DC**Minimum span:** 1 mA**Offset:** Max. 1.5 times span**Load resistance:** Output drive 15 V max. for Output 1;

7 V max. for Output 2

■ **DC Voltage:** -10 - +12 V DC (up to 10 V for Output 2)**Minimum span:** 5 mV**Offset:** Max. 1.5 times span**Load resistance:** Output drive 1 mA max.; at ≥ 0.5 V**INSTALLATION****Power Consumption**•**AC:**

Approx. 4 VA at 100 V

Approx. 5 VA at 200 V

Approx. 6 VA at 240 V

•**DC:** Approx. 3 W**Operating temperature:** -5 to +55°C (23 to 131°F)**Operating humidity:** 30 to 90 %RH (non-condensing)**Mounting:** Surface or DIN rail**Weight:** 200 g (0.44 lbs)**PERFORMANCE in percentage of span****Accuracy:** ±0.3 %**Temp. coefficient:** ±0.015 %/°C (±0.008 %/°F)**Response time:** ≤ 0.5 sec. (0 - 90 %)**Ripple:** 0.5 %p-p max. (100/120 Hz)**Line voltage effect:** ±0.1 % over voltage range**Insulation resistance:** ≥ 100 MΩ with 500 V DC**Dielectric strength:** 2000 V AC @1 minute (input to output 1 to output 2 to power to ground)**STANDARDS & APPROVALS****CE conformity:**

EMC Directive (2004/108/EC)

EMI EN 61000-6-4: 2007

EMS EN 61000-6-2: 2005

Low Voltage Directive (2006/95/EC)

EN 61010-1: 2001

Installation Category II

Pollution Degree 2

Input or output 1 or output 2 to power input:

Reinforced insulation (300 V)

Input to output 1 to output 2: Basic insulation (300 V)

**Approval:**

UL/C-UL nonincendive Class I, Division 2,

Groups A, B, C, and D hazardous locations

(UL 1604:2004, CAN/CSA-C22.2 No.213:1987)

UL/C-UL general safety requirements

(UL 61010B-1:2003, CAN/CSA-C22.2 No.61010-1:1992)

## EXTERNAL DIMENSIONS & TERMINAL ASSIGNMENTS unit: mm (inch)

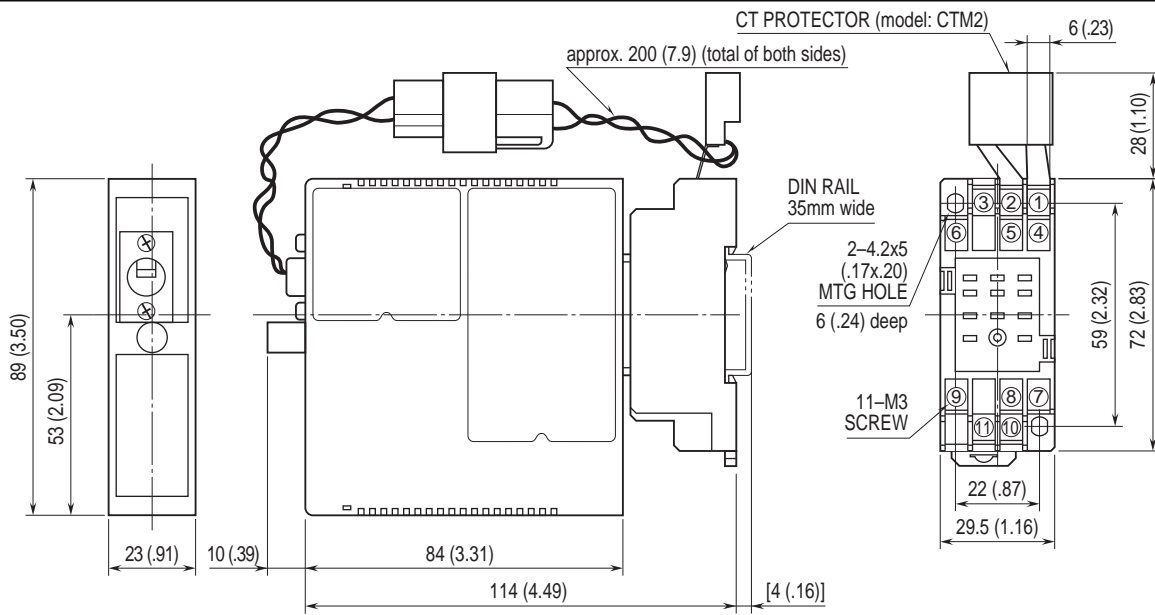

## SCHEMATIC CIRCUITRY & CONNECTION DIAGRAM

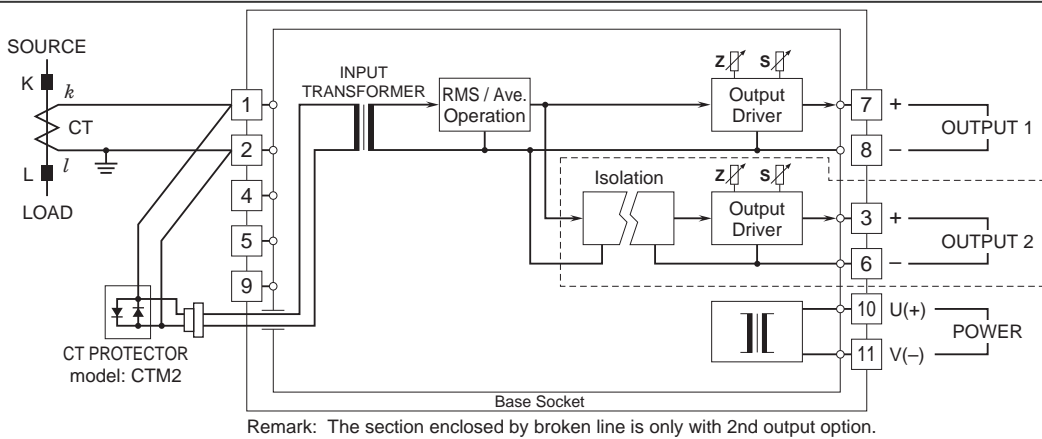

Specifications are subject to change without notice.