



## Modbus/RS-485



## 913/914MB Multi-Channel Analog Input Modules

### DC Current, DC Voltage or AC Current Input

### Limit Alarms or Discrete Outputs

#### Models

913MB: 4 current input channels  
914MB: 4 voltage input channels

#### Input Ranges

0 to 20mA DC,  
±10V DC,  
0 to 20A AC (with 5020-350 sensor)

#### Output

Four output channels:  
Open-drain MOSFETs (1A DC loads)  
0 to 35V DC

#### Network Communication

Modbus-RTU high-speed RS-485

#### Power Requirement

10 to 36V DC,  
24V AC

#### Approvals

CE marked. UL, cUL listed  
Class I; Division 2; Groups A, B, C, D.

## DC Current/Voltage Input Module

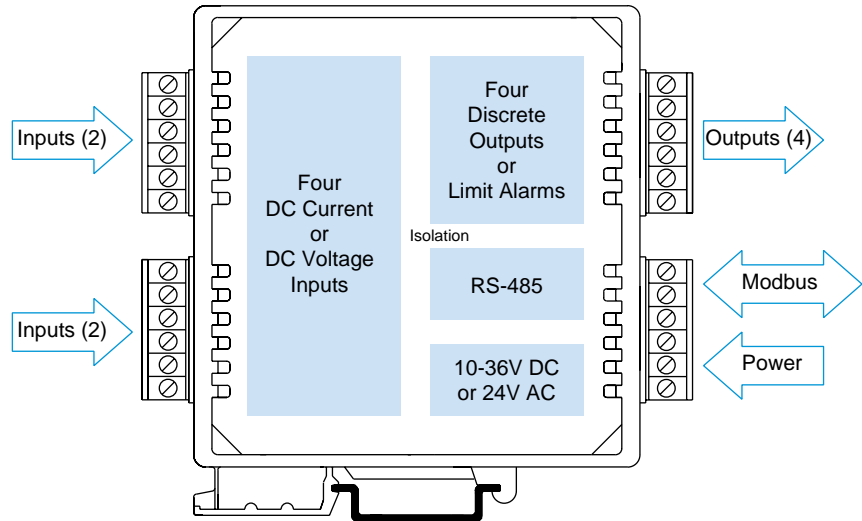

### Description

This signal conditioner is a four-channel analog input module with four discrete outputs. It provides isolation between input, output, power, and network circuits. Network communication adheres to the industry-standard RS-485 Modbus RTU protocol. AC and DC power sources are supported with nonpolarized, diode-coupled terminals.

The inputs accommodate wide DC voltage or current ranges. Flexible discrete outputs operate as alarms or on/off controllers. As limit alarms, each discrete output can be configured with high and/or low setpoints exclusively tied to an analog input channel. Alarm trips function without host communication enabling low-cost stand-alone alarms, as well as local backup for the primary control system. Otherwise, on/off control is based on commands issued by the host system.

Combining flexible transmitter functions, mixed signal I/O, alarm support, and a network interface in a single package, makes this instrument extremely powerful. Multi-channel design adds cost-efficiency and allows high-density mounting. Plus, safe, rugged construction makes these modules reliable for use in both control room and distributed field I/O applications. Custom module configurations are also possible (consult factory for details).

### Special Features

- Standard Modbus RTU protocol with high-speed RS-485 communication (up to 115K bps)
- 16-bit sigma-delta A/D yields 0.1% of range resolution and accuracy
- Four inputs in a single inch-wide module reduces system costs and saves panel space
- Four discrete outputs enable local limit alarms or host-controlled on/off switching
- Heavy-duty 1A solid-state relays provide dependable on/off control of industrial devices
- Self-calibration lowers maintenance costs by reducing periodic manual calibration checks
- Watchdog timers provide a configurable failsafe output state for use when host I/O communication is lost
- Four-way isolation eliminates potential ground loops between power, input, output, and network circuitry
- Self-diagnostics monitor microcontroller activity to detect operational failures (lock-up) and execute a reset to restore communication

#### AC Current Sensor Model 5020-350



For 913MB. Order separately (one per channel).



## Performance

### General Input

**Resolution**  
0.005% or 1 part in 20,000.

**Noise Rejection**  
Normal mode: 40dB @ 60Hz, typical.  
Common mode: 140dB @ 60Hz, typical.

**Input Filter Bandwidth**  
-3dB at 3Hz, typical.

**Input Conversion Rate**  
180ms per channel.

### Current Input (913MB)

**DC Current Input Ranges**  
Range user-configured. Range selected applies to all channels.

0 to 1mA, 0 to 20mA, 4 to 20mA,  
0 to 11.17mA (for use with 5020-350 AC sensor).

**DC Current Input Resistance**  
49.9 ohms.

**DC Current Input Accuracy**  
±0.1% of input range.

### Voltage Input (914MB)

**DC Voltage Input Ranges**  
Range user-configured. Range selected applies to all channels.

±10V, ±5V, ±2.5V, ±1.25V,  
±625mV, ±313mV, ±156mV, ±78mV

**Input Impedance**  
110.5K ohms.

**DC Voltage Input Accuracy**  
±0.1% of input range.

### Discrete Output

**Output Type**  
Four independent open drain MOSFET switches with a common return that operate as low-side switches.

**Output Voltage Range**  
0 to 35V DC.  
External voltage source required.

**Output Current Range**  
0 to 1A DC continuous for each output.

**Output OFF Leakage Current**  
50µA maximum.

**Output ON Resistance**  
0.15 ohms maximum.

**Output Response Time**  
4.1ms typical, from receipt of command to gate transition of the output MOSFET.

**Operation**  
Digital outputs are set to their OFF state following a software or power-on reset. Outputs can optionally be set to user-defined states following a watchdog timeout. Watchdog timeout output control takes precedence over limit alarm control. Alarm control takes precedence over host control.

### Communication

**Supported Modbus Commands**  
The command/response protocol for communicating with this module adheres to the Modbus/RTU standard for the following Modbus Functions.

- Read Coil (Output) Status
- Read Holding Registers
- Read Input Registers
- Force Single Coil (Output)
- Preset Single Register
- Force Multiple Coils (Output)
- Preset Multiple Registers
- Report Slave ID
- Reset Slave

### LED Indicators

LEDs indicate power, status, and discrete level/alarm.

### Power and Isolation

**Power Requirements**  
10 to 36V DC or 22 to 26V AC.

#### Supply Current

Supply	Current Draw
10V DC	125mA maximum
24V DC	50mA maximum
24V AC	100mA rms maximum

#### Isolation

1500V AC for 60 seconds or 250V AC continuous. 4-way isolation between input, network, power, and discrete I/O circuits. Inputs are isolated channel-to-channel for common mode voltage to ±4V DC.

## Ordering Information

### Models

913MB-0900  
914MB-0900  
DC current (913MB) or voltage (914MB) input module

### Accessories

900C-SIP  
Configuration Software Interface Package (includes software CD-ROM for Windows, RS-232/485 converter, and RS-485/three-wire cable)

5034-225  
USB-to-RS232 adapter. See page 41 for more info.

5025-350  
AC current sensor for 913MB. One for each channel.

TBK-B02  
Optional terminal block kit, barrier strip style, 4 pcs.

TBK-S02  
Optional terminal block kit, spring clamp style, 4 pcs.

PS5R-D24  
Power supply (24V DC, 2.1A).  
See Power Supplies on page 183.

For more information on software, network hardware, and mounting accessories, please see Pages 39-41.

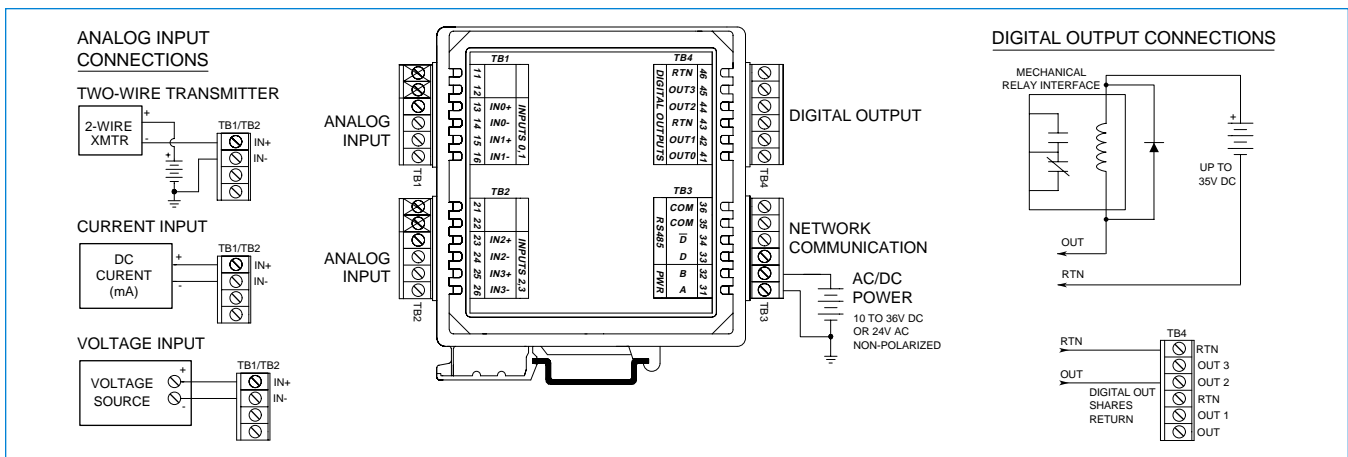



## ■ Accessories

### ■ Configuration Tools

Acromag provides a full set of tools to help you get your modules set up and ready to install.

#### Software Interface Package

See Page 39 for more information.

Includes the following:

- Configuration Software Utility
- Instruction manuals
- Serial port converter
- Interface cable

### ■ Network Devices

Everything you need to drive your network is available from Acromag: isolators, converters, signal boosters, and power sources.

Universal 50W Power Supply (Page 39)

Isolated RS-232/485 Converter (Page 40)

Isolated RS-485 Network Repeater (Page 40)

### ■ Mounting Hardware

Installation is a snap with Acromag accessories.

DIN RAIL Bars (Page 39)

19" Rack-Mount Kit (Page 39)

## ■ General Module Specifications

### ■ Communication Interface

#### Network Communication

Modbus-RTU protocol, RS485 (3-Wire). Standard Protocol implementation as defined under "Modicon Modbus Reference Guide" PI-MBUS-300 Rev. J. Reference: <http://public.modicon.com>. Search on: PI-MBUS-300 for technical publication.

#### Baud Rate

2400, 4800, 9600, 14.4k, 19.2k, 28.8k, 38.4k, 57.6k, 76.8k, or 115.2k baud. Default 9600 baud.

#### Module Addressing

0 to 247, selectable. Default address 247.

#### Network Distance

4000 feet without network repeater.

#### Nodes

Supports up to 32 modules without the use of a network repeater.

#### Parity

Odd, even, or none. Default setting none.

#### Stop Bits

One with parity, one or two with no parity. Default setting is two stop bits with no parity.

#### Watchdog Timer (Hardware)

A hardware watchdog timer is built into each module to perform a reset if the microcontroller fails to return from an operation in a timely manner or "locks up".

#### Watchdog Timer (Network Communication)

All modules have a communication watchdog timer function. The watchdog timer is configurable for timeout periods of up to 18 hours. This timer function monitors I/O communications with the host controller. In the event of lost communications, output ports optionally reset to a user-defined state or level. The watchdog timer restarts with a read/write to an I/O channel.

### ■ Environmental

#### Ambient Temperature

Operation: -25°C to +70°C (-13°F to +158°F). Storage: -40°C to +85°C (-40°F to +185°F).

#### Relative Humidity

5 to 95% non-condensing.

#### Radiated Field Interference Immunity (RFI)

Complies with EN61000-4-3 Level 2 and EN50082-1 (3V/M, 80 to 1000MHz AM and 900MHz keyed).

#### Electrical Fast Transient Immunity (EFT)

EN61000-4-4 Level 1 and EN50082-1 (0.5KV power, signal lines).

#### Electrostatic Discharge (ESD) Immunity

EN61000-4-2 Level 3 and EN50082-1 (8KV/4KV air/direct discharge).

#### Surge Immunity

EN61000-4-5 (0.5KV) and EN50082-1.

#### Radiated Emissions

Meets EN50081-1 for Class B equipment.

#### Approvals

CE marked. UL listed for US and Canada. Class I; Division 2; Groups A, B, C, D.

### ■ Enclosure/Physical

#### Enclosure

Self-extinguishing NYLON type 6.6 polyamide thermoplastic UL94 V-2, color beige; general purpose NEMA Type 1 enclosure.

#### Connectors (Removable Terminal Blocks)

Wire Range: AWG #12-24, stranded or solid copper.

#### Dimensions

1.05W x 4.68H x 4.35D inches  
26.7W x 118.9H x 110.5D mm.

#### DIN Rail Mounting

DIN rail mount, Type EN50022; "T" rail (35mm).

#### Shipping Weight

1 pound (0.45 Kg) packed.

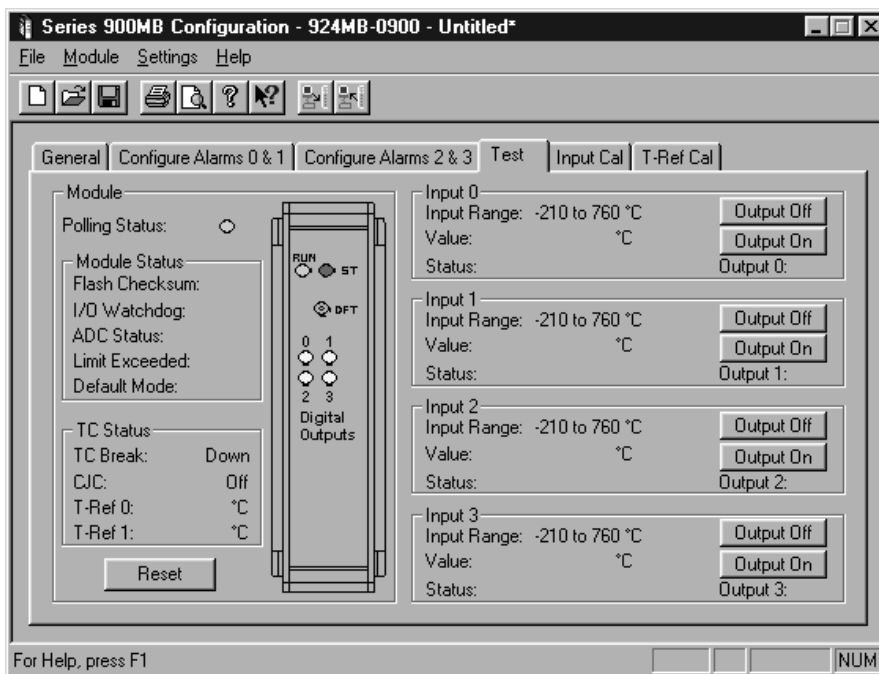

A test page simplifies diagnostics with a live visual display of the module's input and output values.



## 900MB Series Technical Diagrams

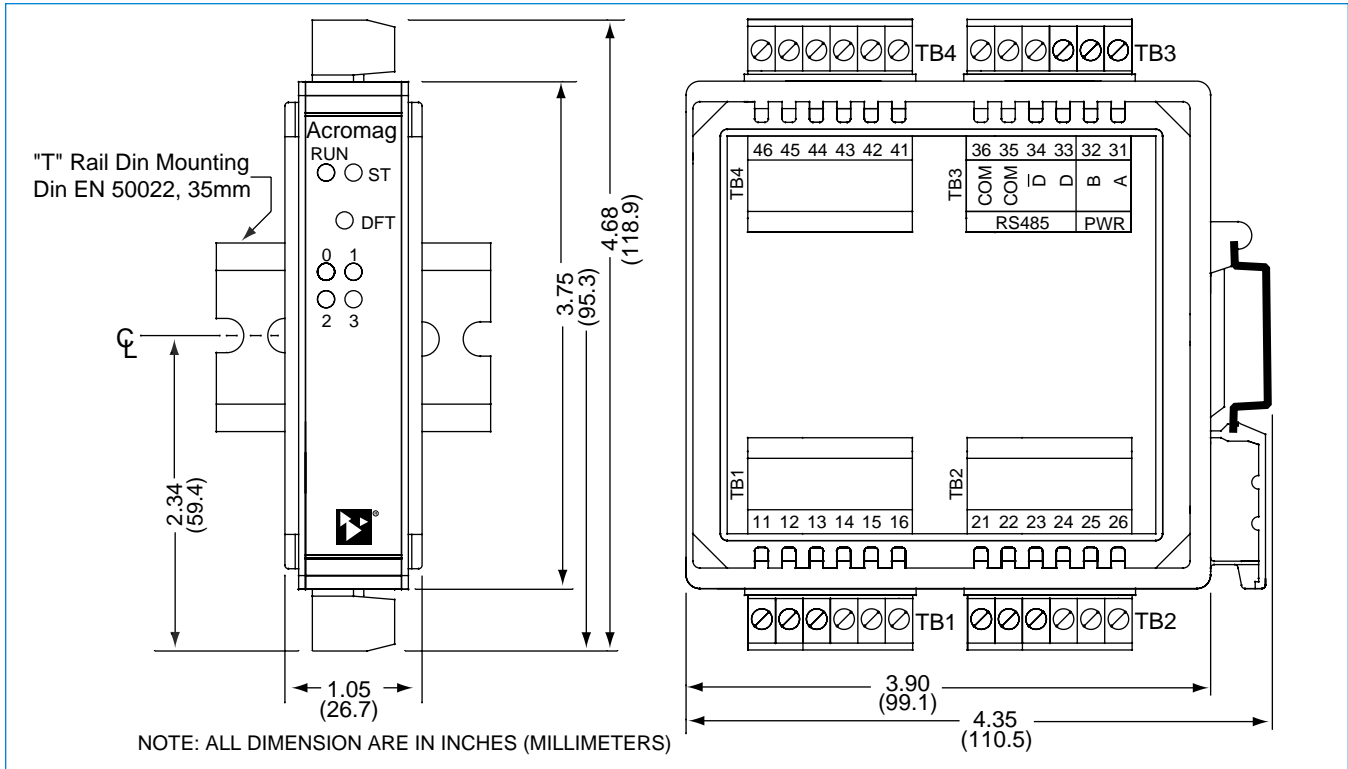

PERSONAL COMPUTER  
W/ WINDOWS 95/98 OR NT



INSTALL MODBUS  
CONFIGURATION  
SOFTWARE

RS-232 SERIAL  
PORT CONNECTOR  
AT BACK OF PC

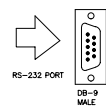

CONNECT THE RS-232  
SIDE OF CONVERTER  
TO THE PC

RS-232 TO RS-485 CONVERTER  
MODEL 5034-214

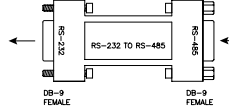

CONNECT THE RS-485  
SIDE OF CONVERTER  
TO THE CABLE

CABLE 5034-202

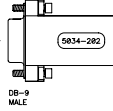

CAUTION: DO NOT CONNECT THE  
CABLE DIRECTLY TO THE PC WITHOUT  
THE CONVERTER, OR DAMAGE TO  
THE MODULE MAY RESULT.

### 900C-SIP COMMUNICATION CONNECTIONS

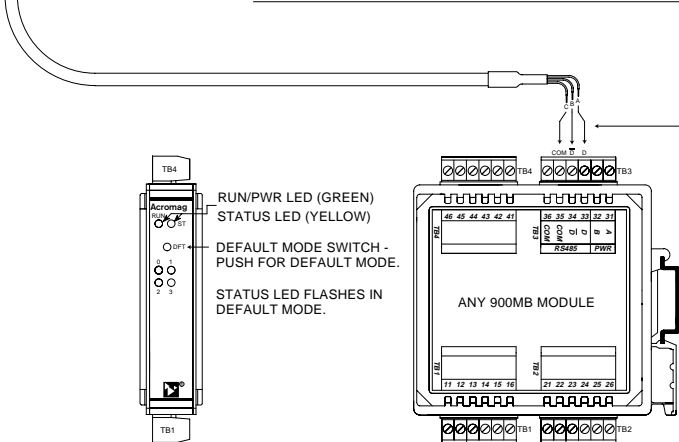

CONNECT WIRES AS SHOWN

WIRE	COLOR	RS-485
A	RED	D
B	BLACK	D̄
C	GREEN	COM

REFER TO THE USER'S MANUAL  
THAT CAME WITH YOUR MODULE  
TO COMPLETE THE MODULE'S  
POWER AND I/O CONNECTIONS

### USB-to-RS232 Adapter



Model 5034-225  
USB-to-RS232 adapter  
Length: 3.15 in (8.0 cm)  
Height: 0.80 in (2.03 cm)  
Width: 1.75 in (4.44 cm)  
Weight: 1.6 oz (45.36 g)



## Configuration Kit

Software Interface Package  
Model No. 900C-SIP

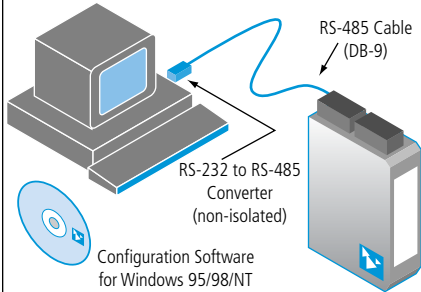

## Software Interface Package

This package includes Windows® Configuration Software, an RS-232-to-485 Serial Port Converter, and an RS-485 Signal Cable. These components provide everything you need to set up a Series 900 I/O module from your desktop PC before installing it on the network.

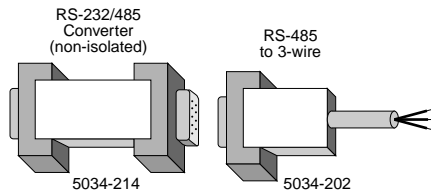

## Ordering Information

- 900C-SIP  
Software Interface Package.  
Includes Configuration Software (5034-186), Non-isolated RS-232 to RS-485 Serial Port Converter (5034-214), and RS-485 Cable (5034-202).  
Items can also be ordered separately below.
- 5034-186  
Configuration Software for Windows (95/98/ME, NT4, 2000) on CD-ROM.
- 5034-214  
Non-isolated RS-232 to RS-485 Serial Port Converter, DB-9F to DB-9F.
- 5034-202  
RS-485 to 3-wire Cable Converter, DB-9M to 3 x 12AWG RS-485 Cable, 8 ft.

## Network Power



## Universal 50W Power Supply

The PS5R-D24 is the ideal power source to drive your network.

**Input Power Requirement**  
Universal power  
85 to 264V AC,  
105 to 370V DC

**Output**  
24V DC, 2.1A (50W)

## Ordering Information

- PS5R-D24  
Universal Power Supply

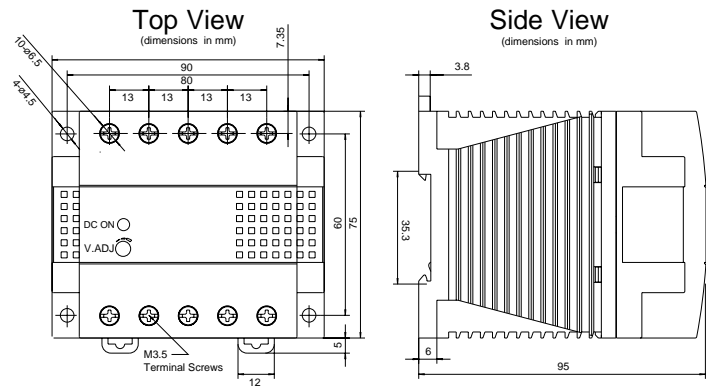

## Mounting Hardware

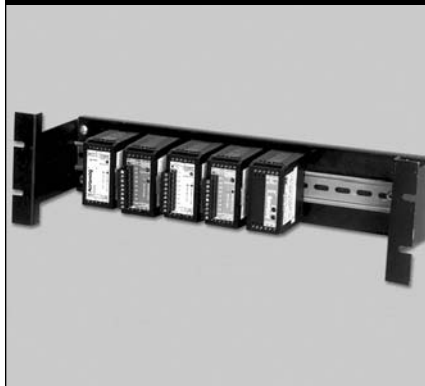

## DIN-Rail Mounting

For your convenience, Acromag offers several mounting accessories to simplify your system installation. Our 19" rack-mount kit provides a clean solution for mounting your I/O modules and a power supply. Or you can buy precut DIN rail strips for mounting on any flat surface.

## Ordering Information

- 20RM-16-DIN  
19" rack-mount kit with DIN rail.
- DIN RAIL 3.0  
DIN RAIL 16.7  
DIN rail strip, Type T, 3 inches (75mm) or 16.7 inches (425mm)

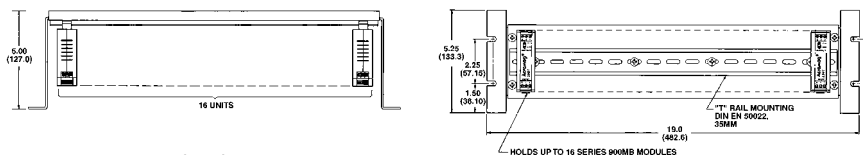

Dimensions in inches (mm).



## RS-232 to RS-485



## 4SCC-TTM x Isolated Signal Converter

This unit provides an isolated interface between the host PC's RS-232 port and RS-485 Modbus network devices. Signal conversion is bidirectional with operation that is transparent to all devices. The RS-485 network supports up to 32 devices (including the 4SCC-TTM Converter) across 4000 foot distances. Installation of additional network devices or extending the distance requires the 4SCR-TTM Network Repeater.

### Specifications

**Baud Rates**  
Switch-selectable from 300 to 38.4K baud.

**Duplex**  
Half duplex only.

**Network Termination Resistors**  
Two terminal blocks and 120 ohm resistors provided to terminate both ends of the RS-485 network.

**Wiring Connectors**  
Terminal blocks with screw clamps for 14-26AWG.

**Operating Temperature Range**  
-25 to 60°C (-13 to 140°F).

**Isolation**  
Withstands 1500V AC surge for 60 seconds (250V AC or 354V DC continuous).

### Ordering Information

**4SCC-TTM-1**  
Signal Converter, 115V AC (power cord included)

**4SCC-TTM-2**  
Signal Converter, 230V AC (power cord included)

**5020-924**  
Signal Cable, 8ft. long, DB-9 to three wires. Connects PC's RS-232 port to 4SCC-TTM-x.

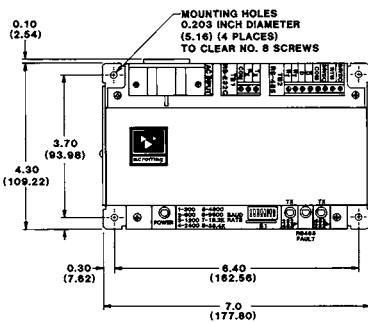

Dimensions in inches (mm).

**Shipping Weight**  
3.0 lbs. (1.4 kg) packed.

BusWorks® Modbus I/O

## RS-485 to RS-485



## 4SCR-TTM x Isolated Network Repeater

This unit isolates and boosts RS-485 signals to extend communication distances or increase the number of devices on the network. Each Repeater permits the addition of a network branch with up to 32 devices (including the 4SCR-TTM) and will transmit RS-485 signals another 4000 feet. Operation is transparent to all devices and no handshaking is required. Two terminal blocks are provided for 120 ohm resistors to terminate both ends of the network branch.

### Specifications

**Baud Rates**  
Switch-selectable from 300 to 38.4K baud.

**Duplex**  
Half duplex only.

**Network Termination Resistors**  
Two terminal blocks and 120 ohm resistors provided to terminate both ends of the RS-485 network.

**RS-485 Wiring Connectors**  
Terminal blocks with screw clamps for 14-26AWG.

**Power Wiring Connections**  
Terminal block with screw clamps for 12-18AWG.

**Operating Temperature Range**  
-25 to 60°C (-13 to 140°F).

**Isolation**  
Withstands 1500V AC surge for 60 seconds (250V AC or 354V DC continuous).

### Ordering Information

**4SCR-TTM-1**  
Signal Converter, 115V AC power

**4SCR-TTM-2**  
Signal Converter, 230V AC power

**40LC-GBW-1**  
115V AC power cord

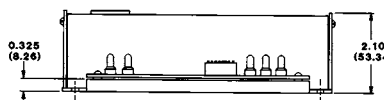
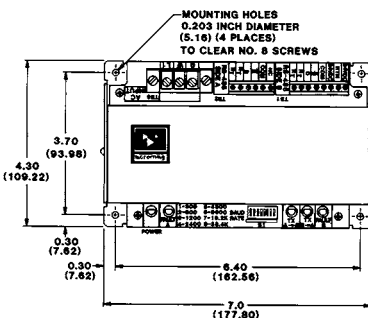

Dimensions in inches (mm).

**Shipping Weight**  
3.0 lbs. (1.4 kg) packed.



## System Connection

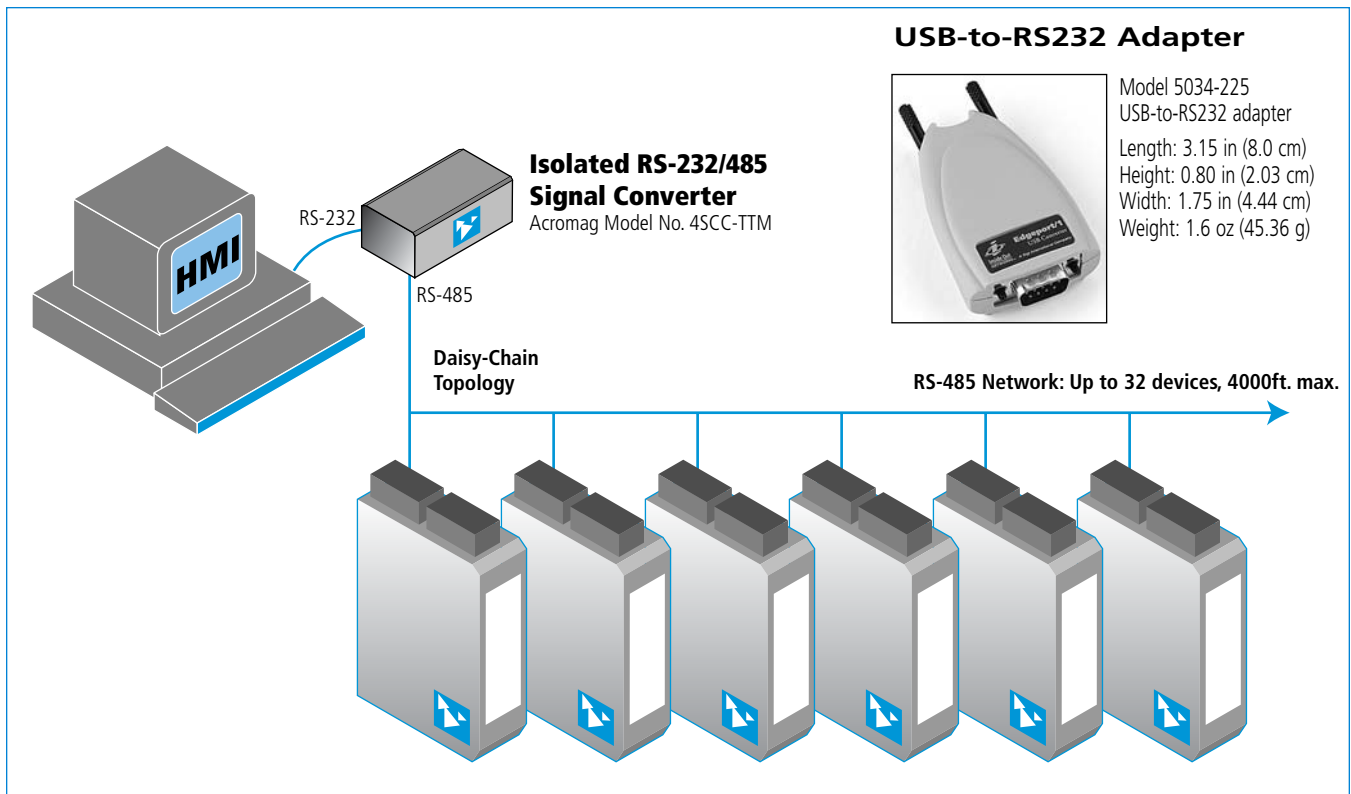

BusWorks® Modbus I/O

## Extending the Network

