

Surface Mount Multilayer Chip Capacitors



GENERAL SPECIFICATIONS

NOTE: Electrical characteristics values - temperature at 20 ± 1 °C, pressure at 86 to 106 Kpa and humidity at 63 to 67 % unless otherwise stated

Rated Voltage U_R (DC): 10 V; 16 V; 25 V; 50 V; 100 V

Capacitance Range: 0.01 μ F to 10 μ F

Tolerance on Capacitance:

After 1000 hours; ± 20 %; - 20/+ 80%

Tan δ :

see Tests and requirements

FEATURES

- Class 3 dielectric
- Four standard sizes
- High capacitance per unit volume
- Supplied in tape on reel
- For high frequency applications
- Ni-barrier with 100 % tin terminations.

APPLICATIONS

- Consumer electronics
- Telecommunications
- Data processing
- Mobile applications

Temperature Coefficient:

+ 30/ - 80%

Insulation Resistance after 120 seconds at U_R (DC):

R_{ins} 10 G Ω minimum or 500 Ω F minimum, whichever is less

Climatic Category (IEC 68): 25/85/21

Test Voltage (DC) for 1 minute: 2.5 x U_R

Ageing: typical 7 % per time decade

DIMENSIONS in inches [millimeters]

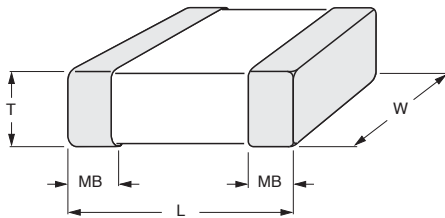

SIZE CODE	L	W	T MAX.	MB
0402	0.040 \pm 0.002 [1.0 \pm 0.05]	0.020 \pm 0.002 [0.5 \pm 0.05]	0.022 [0.55]	0.010 + 0.002/- 0.004 [0.25 + 0.05/- 0.01]
0603	0.063 \pm 0.004 [1.6 \pm 0.10]	0.030 \pm 0.004 [0.8 \pm 0.07]	0.035 [0.87]	0.015 \pm 0.006 [0.40 \pm 0.15]
0805	0.080 \pm 0.006 [2.0 \pm 0.15]	0.050 \pm 0.006 [1.25 \pm 0.15]	0.053 [1.35]	0.020 \pm 0.008 [0.50 \pm 0.20]
1206	0.125 \pm 0.006 [3.2 \pm 0.15]	0.063 \pm 0.006 [1.6 \pm 0.15]	0.069 [1.80]	0.025 \pm 0.008 [0.60 \pm 0.20]

ORDERING INFORMATION

VJ0402	V	103	M	X	Q	C	W1BC
SIZE CODE	DIELECTRIC	CAPACITANCE	TOLERANCE	TERMINATION	VOLTAGE	PACKAGING	TECHNOLOGY
0402 0603 0805 1206	V = Y5V	two significant digits followed by the number of zeros: 103 = 10000	M = ± 20 % Z = - 20/+ 80 %	X = Ni-Barrier	Q = 10 V J = 16 V X = 25 V A = 50 V B = 100 V	C = 7 inch reel/paper P = 13 inch reel/paper T = 7 inch reel/blister R = 13 inch reel/blister	



Class 3 Y5V 10/16/25/50/100 V

Surface Mount Multilayer Chip Capacitors Vishay BCcomponents

SELECTION CHART FOR 10/16/25/50 AND 100 V																					
DIELECTRIC		Y5V																			
EIA CAP	SIZE	0402					0603					0805					1206				
CODE	VDC W	10V	16V	25V	50V	100V	10V	16V	25V	50V	100V	10V	16V	25V	50V	100V	10V	16V	25V	50V	100V
102	1000 pF																				
122	1200																				
152	1500																				
182	1800																				
222	2200																				
272	2700																				
332	3300																				
392	3900																				
472	4700																				
562	5600																				
682	6800																				
822	8200																				
103	0.01 μ F	N	N	N	N		S	S	S	S		A	A	A	A	B	B	B	B	B	B
123	0.012	N	N	N	N		S	S	S	S		A	A	A	A		B	B	B	B	
153	0.015	N	N	N	N		S	S	S	S		A	A	A	A	B	B	B	B	B	B
183	0.018	N	N	N	N		S	S	S	S		A	A	A	A		B	B	B	B	
223	0.022	N	N	N	N		S	S	S	S		A	A	A	A	B	B	B	B	B	B
273	0.027	N	N	N	N		S	S	S	S		A	A	A	A		B	B	B	B	
333	0.033	N	N	N	N		S	S	S	S		A	A	A	A	B	B	B	B	B	B
393	0.039	N	N	N			S	S	S	S		A	A	A	A		B	B	B	B	
473	0.047	N	N	N			S	S	S	S		A	A	A	A	B	B	B	B	B	B
563	0.056	N	N				S	S	S	S		A	A	A	A		B	B	B	B	
683	0.068	N	N				S	S	S	S		A	A	A	A	B	B	B	B	B	B
823	0.082	N	N				S	S	S	S		A	A	A	A		B	B	B	B	
104	0.1 μ F	N	N				S	S	S	S		A	A	A	A	B	B	B	B	B	B
154	0.15	N					S	S	S	S		A	A	A	A		B	B	B	B	C
224	0.22	N					S	S	S			A	A	A	A		B	B	B	B	C
334	0.33						S	S	S			B	B	B	B		B	B	B	B	
474	0.47						S	S				B	B	B			B	B	B	B	
684	0.68						S					B	B	D			B	B	B	B	
105	1 μ F						S					B	B	D			C	C	C	C	
155	1.5											D	D				C	C	C		
225	2.2											D	D				C	C	C		
335	3.3											D					D	D	D		
475	4.7											D					D	D			
685	6.8																D				
106	10 μ F																D				
226	22 μ F																				



PACKAGING QUANTITIES				
THICKNESS CLASSIFICATION (mm)	AMOUNT PER REEL			
	Δ180 mm; 7 inch			
	0402	0603	0805	1206
A = 0.6 ± 0.1	-	-	Paper 4 Kp/Reel	-
B = 0.8 ± 0.1	-	-	Paper 4 Kp/Reel	Paper 4 Kp/Reel
C = 0.95 ± 0.1	-	-	-	Plastic 3 Kp/Reel
D = 1.25 ± 0.1	-	-	Plastic 3 Kp/Reel	Plastic 3 Kp/Reel
G = 1.60 ± 0.2	-	-	-	Plastic 2 Kp/Reel
S = 0.8 ± 0.07	-	Paper 4 Kp/Reel	-	-
N = 0.50 ± 0.05	Paper 10 Kp/Reel	-	-	-
K = 2.00 ± 0.2	-	-	-	-
M = 2.5 ± 0.30	-	-	-	-

PACKAGING QUANTITIES				
THICKNESS CLASSIFICATION (mm)	AMOUNT PER REEL			
	Δ330 mm; 13 inch			
	0402	0603	0805	1206
A = 0.6 ± 0.1	-	-	Paper 15 Kp/Reel	-
B = 0.8 ± 0.1	-	-	Paper 15 Kp/Reel	Paper 15 Kp/Reel
C = 0.95 ± 0.1	-	-	-	Plastic 10 Kp/Reel
D = 1.25 ± 0.1	-	-	Plastic 10 Kp/Reel	Plastic 10 Kp/Reel
G = 1.60 ± 0.2	-	-	-	-
S = 0.8 ± 0.07	-	Paper 15 Kp/Reel	-	-
N = 0.50 ± 0.05	Paper 50 Kp/Reel	-	-	-
K = 2.00 ± 0.2	-	-	-	-
M = 2.5 ± 0.30	-	-	-	-

COVER TAPE (POLYESTER - ANTISTATIC)

PROPERTIES OF COVER TAPE	
PARAMETER	WIDTH
Breaking force	≥ 10.7 N
Elongation at break	≥ 63 %
Surface resistance	< 10 ¹⁰ Ω /sq.
Softening point	71 ± 5 °C
Thickness	62 μm

CARRIER TAPE (POLYCARBONATE)

PROPERTIES OF CARRIER TAPE	
PARAMETER	WIDTH
Thickness	190 to 280 μm
Tensile strength at break	> 60 N /mm ²
Elongation at break	100 to 150 %
Surface resistance	> 10 ¹² Ω /sq.

PAPER TAPE SPECIFICATIONS

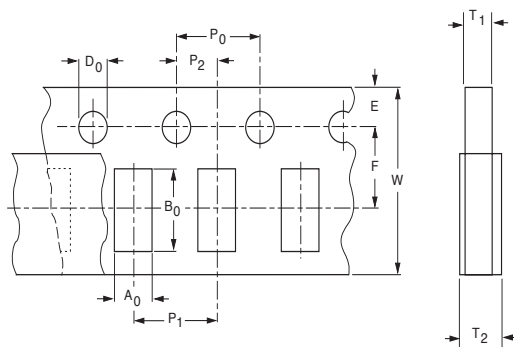

DIMENSIONS OF PAPER TAPE in millimeters								
SYMBOL	PRODUCT SIZE CODE							
	0402		0603		0805		1206	
	SIZE	TOL.	SIZE	TOL.	SIZE	TOL.	SIZE	TOL.
A ₀	0.62	±0.05	1.02	±0.05	1.50	±0.10	2.00	±0.15
B ₀	1.12	±0.05	1.82	±0.05	2.30	±0.10	3.50	±0.15
W	8.00	±0.10	8.00	±0.10	8.00	±0.10	8.00	±0.10
E	1.75	±0.10	1.75	±0.10	1.75	±0.10	1.75	±0.10
F	3.50	±0.05	3.50	±0.05	3.50	±0.05	3.50	±0.05
D ₀	1.55	±0.05	1.55	±0.05	1.55	±0.05	1.55	±0.05
P ₀	4.00	±0.10	4.00	±0.10	4.00	±0.10	4.00	±0.10
P ₁	2.00	±0.05	4.00	±0.10	4.00	±0.10	4.00	±0.10
P ₂	2.00	±0.05	2.00	±0.05	2.00	±0.05	2.00	±0.05



BLISTER TAPE SPECIFICATIONS

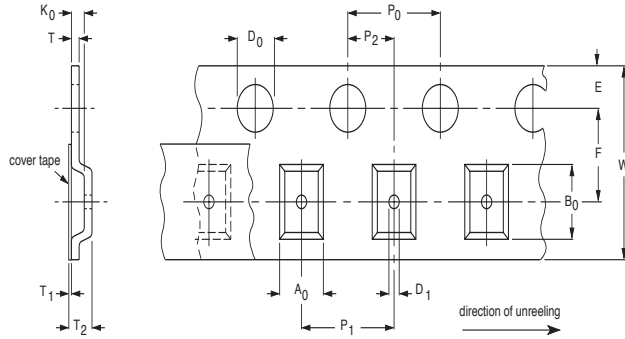

DIMENSIONS OF BLISTER TAPE in millimeters			
DIMENSION	PRODUCT		TOLERANCE
	0805	1206	
A_0	< 1.55	< 2.00	-
B_0	< 2.45	< 3.60	-
W	8.00	8.00	± 0.20
E	1.75	1.75	± 0.10
F	3.50	3.50	± 0.05
D_0	1.50	1.50	+ 0.10/ - 0
D_1	1.00	1.00	± 0.10
P_0	4.00	4.00	± 0.05
P_1	4.00	4.00	± 0.10
P_2	2.00	2.00	± 0.05

REEL SPECIFICATIONS

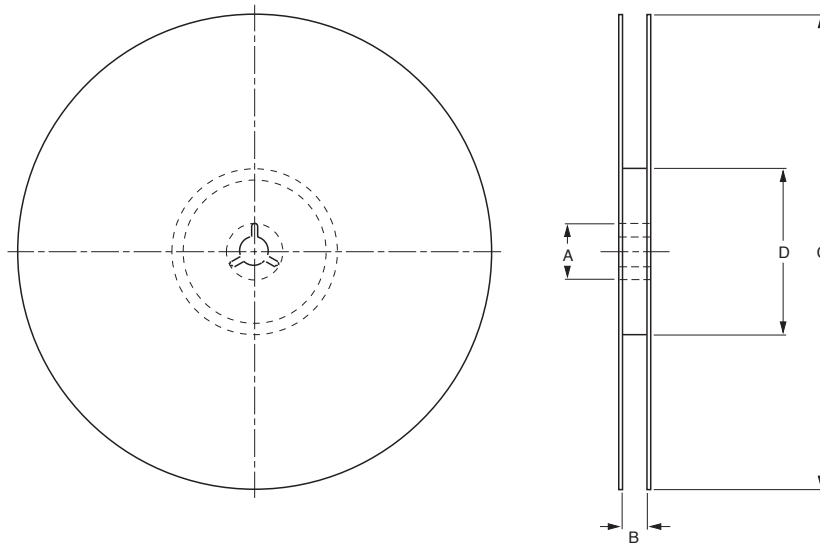

	REEL DIMENSIONS AND TAPE WIDTH in millimeters	
	$\varnothing 180$ mm; 7 inch	$\varnothing 330$ mm; 13 inch
A	13.0 ± 1.0	13.0 ± 0.5
B	9.0 ± 1.0	9.0 ± 0.5
C	178.0 ± 1.0	330.0 ± 1.0
D	60.5 ± 1.0	100.0 ± 1.0

METHOD OF MOUNTING AND DIMENSIONS OF SOLDER LANDS

For normal use the capacitors may be mounted on printed-circuit boards or ceramic substrates by applying wave soldering and reflow soldering.

An improper combination of soldering, substrate and chip size can lead to a damaging of the component. The risk increases with the chip size and with temperature fluctuations (> 100 °C) Therefore, it is advised to use the smallest possible size and follow the dimensional recommendations given.



SOLDERING GRAPHS

IR REFLOW WITH SnAgCu SOLDER

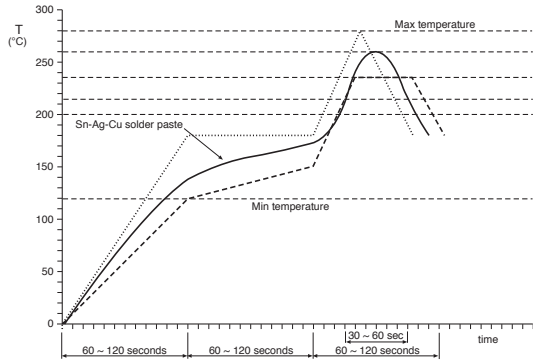

IR REFLOW WITH SnPb SOLDER

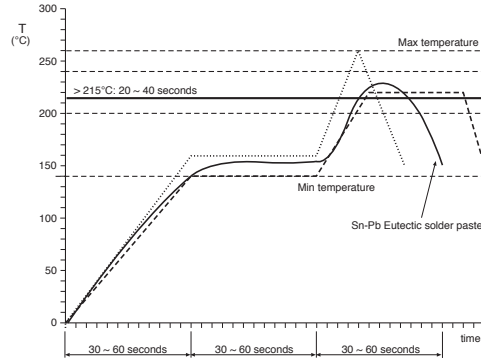

WAVE SOLDERING

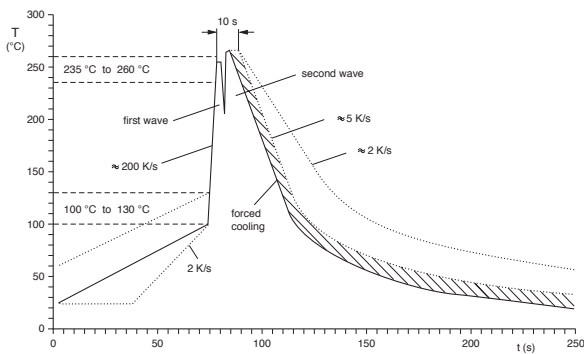

REFLOW SOLDERING

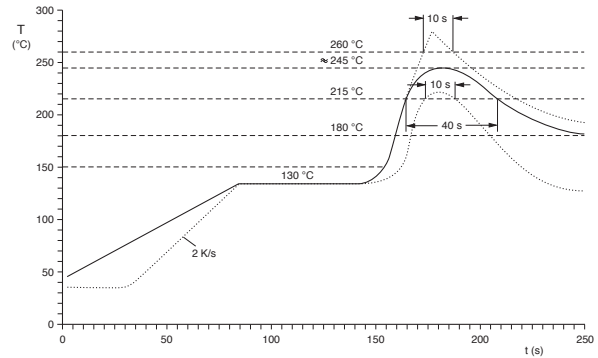

RECOMMENDED DIMENSIONS OF SOLDER LANDS in millimeters

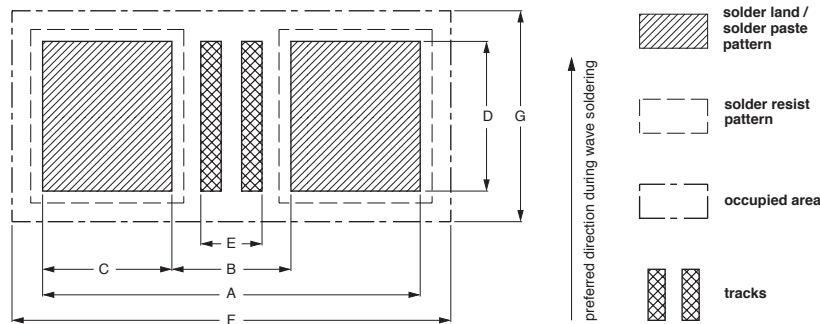



REFLOW SOLDERING									
SIZE CODE	FOOTPRINT DIMENSIONS in mm							PROCESSING REMARKS	PLACEMENT ACCURACY
	A	B	C	D	E	F	G		
0402	1.50	0.50	0.50	0.50	0.10	1.75	0.95	IR or hot plate soldering	± 0.15
0603	2.30	0.70	0.80	0.80	0.20	2.55	1.40		± 0.25
0805	2.80	1.00	0.90	1.30	0.40	3.08	1.85		± 0.25
1206	4.00	2.20	0.90	1.60	1.60	4.25	2.25		± 0.25

WAVE SOLDERING									
SIZE CODE	FOOTPRINT DIMENSIONS in mm							PROPOSED NUMBER AND DIMENSIONS OF DUMMY TRACKS (mm)	PLACEMENT ACCURACY (mm)
	A	B	C	D	E	F	G		
0603	2.40	1.00	0.70	0.80	0.20	3.10	1.90	1 x (0.2 x 0.8)	± 0.10
0805	3.20	1.40	0.90	1.30	0.36	4.10	2.50	1 x (0.3 x 1.3)	± 0.15
1206	4.80	2.30	1.25	1.70	1.25	5.90	3.20	3 x (0.25 x 1.7)	± 0.25

TEST CONDITIONS IN STATIC SOLDER BATH	
PARAMETER	DESCRIPTION
SOLDERABILITY	
95 % covered with smooth and bright solder coating	CECC requirement: 235 ± 5 °C for 2 ± 0.5 seconds IEC requirement: 215 ± 3 °C for 3 ± 0.3 seconds
RESISTANCE TO LEACHING	
10 % of the metallization of the edges of the head face may be missing (inner electrodes are not visible)	260 ± 5 °C for 30 ± 1 second

TESTS AND REQUIREMENTS

TESTS PROCEDURES AND REQUIREMENTS		
TEST	PROCEDURE	REQUIREMENTS
Visual and mechanical		no visible damage dimensions in accordance with specification
Capacitance	C ≤ 10 μF; 1.0 ± 0.2 Vrms; 1 kHz ± 10 % C > 10 μF; 0.5 ± 0.2 Vrms; 120 kHz ± 20 %	shall not exceed the limits given in the detailed specification
Dissipation factor	C ≤ 10 μF; 1.0 ± 0.2 Vrms; 1 kHz ± 10 % C > 10 μF; 0.5 ± 0.2 Vrms; 120 kHz ± 20 %	DF: ≤ 5.0 %: 50 V, 25 V (except 0603 ≥ 0.1 μF; 0805 ≥ 0.33 μF; 1206 ≥ 0.1 μF, ≤ 7.0 %) ≤ 7.0 % (C < 1.0 μF, 16 V); ≤ 9.0 % (C ≥ 1.0 μF, 16 V); ≤ 12.5 % (10 V)
Dielectric strength	250 % of rated voltage for 1 to 5 seconds, charge and discharge current less than 50 mA	no visible damage or flash-over during test
Insulation resistance	at U _R (DC) for maximum 120 seconds	10 GΩ minimum or 500 ΩF minimum, whichever is less
Temperature coefficient	with no electrical load: – 25 to 85 °C at T _{amb} = 20 °C	within + 30/– 80%
Bending test	the middle part of the substrate shall be pressurized by means of the pressurizing rod at a rate of about 1 mm per second until the deflection becomes 1 mm and then the pressure shall be maintained for 5 ± 1 second; measurement after 48 ± 4 hours at room temperature	no visible damage ΔC/C: ≤ ± 30 % this capacitance change means the change of capacitance under specified flexure of substrate from the capacitance measured before the test



TESTS PROCEDURES AND REQUIREMENTS		
TEST	PROCEDURE	REQUIREMENTS
Solderability	230 ± 5 °C for 2 ± 0.5 seconds; Solder: SN63A	95 % minimum coverage of entire metallized area
Resistance to soldering heat	Solder temperature: 260 ± 5 °C Dipping time: 10 ± 1 seconds Solder: SN63A Before initial measurement: Perform 150 + 0/- 10 °C for 1 hour and then set for 48 ± 4 hours at room temperature. Preheating: 120 to 150 °C for 1 minute before immerse the capacitor in a eutectic solder. Measurement to be made after 48 ± 4 hours at room temperature	no visible damage $\Delta C/C: \leq \pm 20 \%$ DF, R_{ins} and dielectric strength to meet initial requirements
Temperature cycle	Test temperature – 55 to 85 °C: – 55 °C – 3/+ 0 °C for 30 ± 3 minutes; Room temperature for 2 to 3 minutes; X5R: 85 °C + 3/- 0 °C for 30 ± 3 minutes; Room temperature for 2 to 3 minutes Measurement to be made after 48 ± 4 hours at room temperature	no visible damage $\Delta C/C: \leq \pm 20 \%$ DF, R_{ins} and dielectric strength to meet initial requirements
Humidity test (damp heat steady state)	Test temperature: 40 ± 2 °C Humidity: 90 to 95 % RH Test time: 500 + 24/- 0 hours Measurement to be made after 48 ± 4 hours at room temperature	$\Delta C/C: \leq \pm 30 \%$ DF: $\leq 7.5 \% U_R$ (DC): ≥ 50 V, 25 V (except 0603 $\geq 0.1 \mu F$; 0805 $\geq 0.33 \mu F$; 1206 $\geq 1 \mu F, \leq 10 \%$) $\leq 10 \%$ (C < 1.0 μF , 16 V); $\leq 12.5 \%$ (C $\geq 1.0 \mu F$, 16 V; 0402 $\geq 0.068 \mu F$) $\leq 15 \%$ (10 V) R_{ins} : 1 G Ω minimum or 50 ΩF minimum, whichever is less
Humidity load (damp heat)	Test temperature: 40 ± 2 °C Humidity: 90 to 95 % RH Test time: 500 + 24/- 0 hours To apply voltage: rated voltage Measurement to be made after 48 ± 2 hours at room temperature	no visual damage $\Delta C/C: \pm 30 \%$ DF: $\leq 7.5 \% U_R$ (DC): ≥ 50 V, 25 V (except 0603 $\geq 0.1 \mu F$; 0805 $\geq 0.33 \mu F$; 1206 $\geq 1 \mu F, \leq 10 \%$) $\leq 10 \%$ (C < 1.0 μF , 16 V); $\leq 12.5 \%$ (C $\geq 1.0 \mu F$, 16 V; 0402 $\geq 0.068 \mu F$) $\leq 15 \%$ (10 V) R_{ins} : 500 M Ω minimum or 25 ΩF minimum, whichever is less
Adhesive strength of termination	Pressurizing force 5 N (\leq 0603) and 10 N ($>$ 0603) Test time 10 ± 1 second	no visible damage
Vibration resistance	Vibration frequency: 10 to 55 Hz/minute; Total amplitude: 1.5 mm Test time: 6 hours (2 hours each in 3 mutually perpendicular directions)	no visible damage or removal of the terminations
High temperature load (endurance)	Test temperature 85 ± 3 °C; To apply voltage: 200 % of rated voltage Test time: 1000 + 24/- 0 hours; Measurement after 48 ± 4 hours at room temperature	no visual damage $\Delta C/C: \leq \pm 30 \%$ DF: $\leq 7.5 \% U_R$ (DC): ≥ 50 V, 25 V (except 0603 $\geq 0.1 \mu F$; 0805 $\geq 0.33 \mu F$; 1206 $\geq 0.1 \mu F, \leq 10 \%$) $\leq 10 \%$ (C < 1.0 μF , 16 V); $\leq 12.5 \%$ (C $\geq 1.0 \mu F$, 16 V; 0402 $\geq 0.068 \mu F$) $\leq 15 \%$ (10 V) R_{ins} : 1 G Ω minimum. or 50 ΩF minimum, whichever is less