

**Space-saving Dual Output Signal Conditioners
Mini-MW Series**

THERMOCOUPLE TRANSMITTER

Functions & Features

- Accepts direct input from a thermocouple and provides a standard process signal
- 5-segment linearization
- Burnout
- High-accuracy cold junction compensation
- Fast response type available
- CE marking
- UL approval

Typical Applications

- High-accuracy cold junction compensation benefits narrow span measurements
- 0.1 μ A burnout sensing enables long distance transmission with minimum offset drifts
- Electric furnace (isolation ensured even when 200 V AC power for heater leaks through furnace wall)
- No burnout type can connect to a single T/C in parallel with a recorder

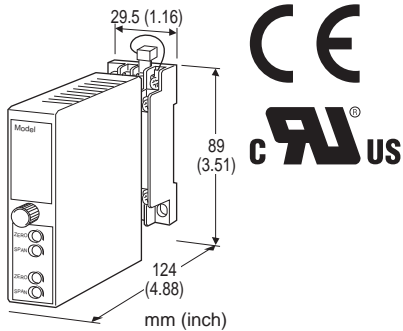

MODEL: W2TS-[1][2][3]-[4][5]

ORDERING INFORMATION

- Code number: W2TS-[1][2][3]-[4][5]
- Specify a code from below for each [1] through [5]. (e.g. W2TS-2A6-M2/BL/CE/Q)
- Temperature range (e.g. 0 - 800°C)
- Special output ranges (For codes Z & 0)
- Specify the specification for option code 'Q.' (e.g. /C01/V01)

Note: If one of the outputs should be a current range, specify it for the Output 1 to allow a greater load.

[1] INPUT THERMOCOUPLE

- 1: (PR) (Usable Range 0 to 1760°C, 32 to 3200°F)
- 2: K (CA) (Usable range -270 to +1370°C, -454 to +2498°F)
- 3: E (CRC) (Usable range -270 to +1000°C, -454 to +1832°F)
- 4: J (IC) (Usable range -210 to +1200°C, -346 to +2192°F)
- 5: T (CC) (Usable range -270 to +400°C, -454 to +752°F)
- 6: B (RH) (Usable range 0 to 1820°C, 32 to 3308°F)
- 7: R (Usable range -50 to +1760°C, -58 to +3200°F)
- 8: S (Usable range -50 to +1760°C, -58 to +3200°F)
- N: N (Usable range -270 to +1300°C, -454 to +2372°F)
- 0: Specify

[2] OUTPUT 1

Current

- A: 4 - 20 mA DC (Load resistance 750 Ω max.)
- B: 2 - 10 mA DC (Load resistance 1500 Ω max.)
- C: 1 - 5 mA DC (Load resistance 3000 Ω max.)
- D: 0 - 20 mA DC (Load resistance 750 Ω max.)
- E: 0 - 16 mA DC (Load resistance 900 Ω max.)
- F: 0 - 10 mA DC (Load resistance 1500 Ω max.)
- G: 0 - 1 mA DC (Load resistance 15 k Ω max.)
- Z: Specify current (See OUTPUT SPECIFICATIONS)

Voltage

- 1: 0 - 10 mV DC (Load resistance 10 k Ω min.)
- 2: 0 - 100 mV DC (Load resistance 100 k Ω min.)
- 3: 0 - 1 V DC (Load resistance 1000 Ω min.)
- 4: 0 - 10 V DC (Load resistance 10 k Ω min.)
- 5: 0 - 5 V DC (Load resistance 5000 Ω min.)
- 6: 1 - 5 V DC (Load resistance 5000 Ω min.)
- 0: Specify voltage (See OUTPUT SPECIFICATIONS)

[3] OUTPUT 2

Y: None

Current

- A: 4 - 20 mA DC (Load resistance 350 Ω max.)
- B: 2 - 10 mA DC (Load resistance 700 Ω max.)
- C: 1 - 5 mA DC (Load resistance 1400 Ω max.)
- D: 0 - 20 mA DC (Load resistance 350 Ω max.)
- E: 0 - 16 mA DC (Load resistance 430 Ω max.)
- F: 0 - 10 mA DC (Load resistance 700 Ω max.)
- G: 0 - 1 mA DC (Load resistance 7000 Ω max.)
- Z: Specify current (See OUTPUT SPECIFICATIONS)

Voltage

Same range availability as Output 1

[4] POWER INPUT

AC Power

- M2: 100 - 240 V AC (Operational voltage range 85 - 264 V, 47 - 66 Hz)
- (90 - 264 V for UL)

DC Power

R: 24 V DC
(Operational voltage range 24 V \pm 10 %, ripple 10 %p-p max.)
R2: 11 - 27 V DC
(Operational voltage range 11 - 27 V, ripple 10 %p-p max.)
(Select '/N' for 'Standards & Approvals' code.)
P: 110 V DC
(Operational voltage range 85 - 150 V, ripple 10 %p-p max.)
(110 V \pm 10 % for UL)

[5] OPTIONS (multiple selections)

Response Time (0 - 90 %)

blank: Standard (\leq 0.5 sec.)

/K: Fast Response (Approx. 25 msec.)

Burnout

blank: Upscale burnout

/BL: Downscale burnout

/BN: No burnout

Standards & Approvals (must be specified)

/N: Without CE or UL

/CE: CE marking

/UL: UL approval, CE marking

Other Options

blank: none

/Q: Option other than the above (specify the specification)

(UL not available)

SPECIFICATIONS OF OPTION: Q (multiple selections)

COATING (For the detail, refer to M-System's web site.)

/C01: Silicone coating

/C02: Polyurethane coating

/C03: Rubber coating

ADJUSTMENT

/V01: Multi-turn fine adjustment

TERMINAL SCREW MATERIAL

/S01: Stainless steel

GENERAL SPECIFICATIONS

Construction: Plug-in

Connection: M3 screw terminals (torque 0.8 N·m)

Housing material: Flame-resistant resin (black)

Isolation: Input to output 1 to output 2 to power

Overrange output: Approx. -10 to +120 % at 1 - 5 V

Zero adjustment: -5 to +5 % (front)

Span adjustment: 95 to 105 % (front)

Burnout: Upscale standard; downscale or no burnout optional

Linearization: Standard

Cold junction compensation: CJC sensor attached to the input terminals

INPUT SPECIFICATIONS

Minimum span: 3 mV

Offset: Max. 1.5 times span

Input resistance: 30 k Ω min.

Burnout sensing: 0.1 μ A

MIN. span (in °C)

(PR): min. span 370°C

K (CA): min. span 75°C

E (CRC): min. span 50°C

J (IC): min. span 60°C

T (CC): min. span 75°C

B (RH): min. span 780°C

R: min. span 360°C

S: min. span 380°C

N: min. span 110°C

MIN. span (in °F)

(PR): min. span 670°F

K (CA): min. span 140°F

E (CRC): min. span 90°F

J (IC): min. span 110°F

T (CC): min. span 140°F

B (RH): min. span 1410°F

R: min. span 650°F

S: min. span 690°F

N: min. span 200°F

Remark: The described accuracy may be partially not satisfied when the temperature ranges below 0°C. Consult factory.

OUTPUT SPECIFICATIONS

■ **DC Current:** 0 - 20 mA DC

Minimum span: 1 mA

Offset: Max. 1.5 times span

Load resistance: Output drive 15 V max. for Output 1;

7 V max. for Output 2

■ **DC Voltage:** -10 - +12 V DC (up to 10 V for Output 2)

Minimum span: 5 mV

Offset: Max. 1.5 times span

Load resistance: Output drive 1 mA max.; at \geq 0.5 V

INSTALLATION

Power Consumption

• **AC Power input:**

Approx. 4 VA at 100 V

Approx. 5 VA at 200 V

Approx. 6 VA at 240 V

• **DC power input:** Approx. 3 W

Operating temperature: -5 to +55°C (23 to 131°F)

Operating humidity: 30 to 90 %RH (non-condensing)

Mounting: Surface or DIN rail

Weight: 200 g (0.44 lbs)

PERFORMANCE in percentage of span

Accuracy: $\pm 0.4\%$ (at over 400°C or 750°F for R, S and PR;
over 770°C or 1420°F for B)

Cold junction compensation error

(at 25°C $\pm 10^\circ\text{C}$ or 77°F $\pm 18^\circ\text{F}$)

K, E, J, T & N: $\pm 0.5^\circ\text{C}$ or $\pm 0.9^\circ\text{F}$

S, R & PR: $\pm 1^\circ\text{C}$ or $\pm 1.8^\circ\text{F}$

Temp. coefficient: $\pm 0.015\%/^\circ\text{C}$ ($\pm 0.008\%/^\circ\text{F}$)

(at over 770°C or 1420°F for B)

Burnout response: ≤ 10 sec.

Line voltage effect: $\pm 0.1\%$ over voltage range

Insulation resistance: $\geq 100\text{ M}\Omega$ with 500 V DC

Dielectric strength: 2000 V AC @1 minute (input to output
1 to output 2 to power to ground)

STANDARDS & APPROVALS

CE conformity:

EMC Directive (2004/108/EC)

EMI EN 61000-6-4: 2007

EMS EN 61000-6-2: 2005

Low Voltage Directive (2006/95/EC)

EN 61010-1: 2001

Installation Category II

Pollution Degree 2

Input or output 1 or output 2 to power input:

Reinforced insulation (300 V)

Input to output 1 to output 2: Basic insulation (300 V)

Approval:

UL/C-UL nonincendive Class I, Division 2,

Groups A, B, C, and D hazardous locations

(UL 1604:2004, CAN/CSA-C22.2 No.213:1987)

UL/C-UL general safety requirements

(UL 61010B-1:2003, CAN/CSA-C22.2 No.61010-1:1992)

DIMENSIONS unit: mm (inch)

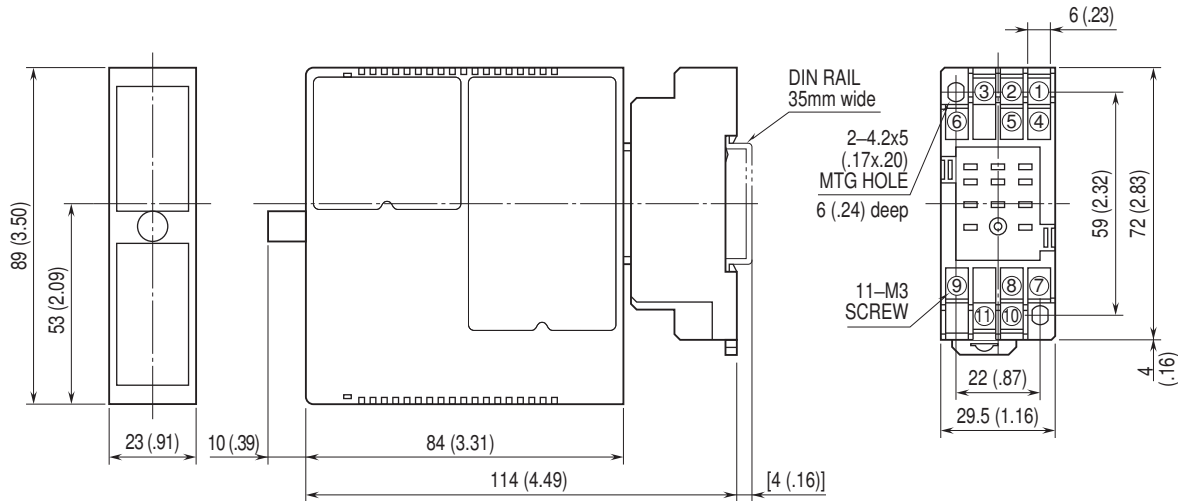

When mounting, no extra space is needed between units.

TERMINAL ASSIGNMENTS unit: mm (inch)

CJC SENSOR
(model: CJM)

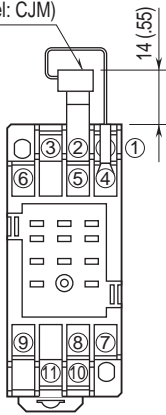

SCHEMATIC CIRCUITRY & CONNECTION DIAGRAM

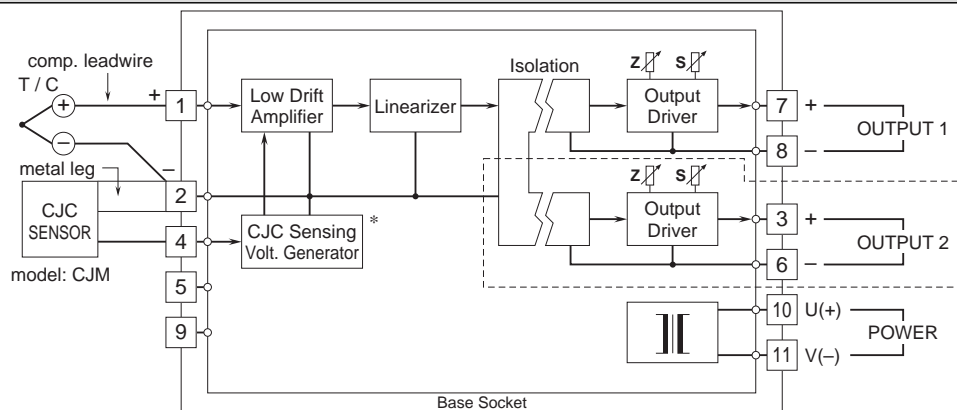

*Deleted with B thermocouple.

Remark: The section enclosed by broken line is only with 2nd output option.



Specifications are subject to change without notice.