

F7 - 3U/6U CompactPCI/PXI Pentium III SBC

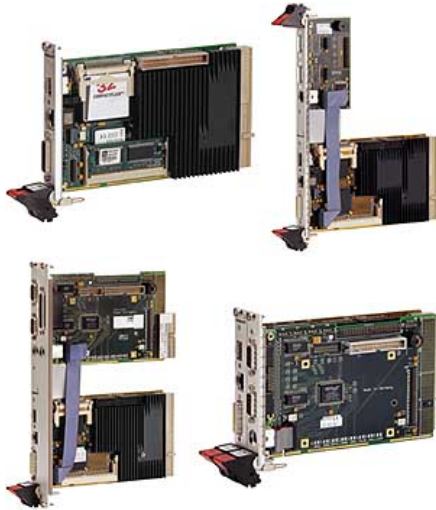

- ◆ Celeron/Pentium III 733/850MHz
- ◆ 1-slot 32-bit CompactPCI system master
- ◆ PXI system controller
(Peripheral-slot version on request)
- ◆ 256MB DRAM, CompactFlash
- ◆ Graphics controller/digital video output
- ◆ 10/100Base-TX Fast Ethernet
- ◆ USB
- ◆ 2 COMs, IDE, floppy, parallel keyboard/mouse
via extension card
- ◆ On-board hard disk via extension card
- ◆ Extension kit for 6U systems

Equipped with a Celeron or Pentium III processor, the F7 is a powerful 3U CPU board based on Socket 370. It is a perfect match as a system-slot card for any CompactPCI system, with the system slot being placed either left or right in the enclosure.

A peripheral-slot version of the F7 is available on request.

For 6U CompactPCI and PXI systems the F7 is available with a special mounting kit including a 6U front panel. The board is provided with the i810/i810E chip set, which contains an embedded graphics controller. The DVI interface allows for attachment of both advanced and legacy flat-panel displays and CRT monitors. The onboard USB port is a universal interface to a variety

of peripheral devices (such as keyboard, mouse, printer, modem, or video camera). For high-speed networking, the F7 features a 10/100Mbit/s Fast Ethernet interface. All connections mentioned above are conveniently available at the card's front panel. For mass storage, the F7 provides enhanced EIDE features, suitable for any EIDE hard disk and CD-ROM drive. An onboard CompactFlash slot allows use of silicon disks. The jumperless board can be used with a front-side bus clock of up to 133MHz. Equipped with a PCI-bridge chip, the F7 offers a full CompactPCI interface for reliable system expansion. Last but not least, the F7's General Software BIOS was especially designed for embedded system applications.

Technical Data

CompactPCI Bus

- 3U CompactPCI CPU board rev. 3.0 compliant
- 32-bit CompactPCI system slot functionality with 7 possible external loads due to PCI-to-PCI bridge
- PCI-to-PCI bridge
- Single-slot solution
- V(I/O): +5V (+3.3V on request)

CPU

- Celeron or Pentium III
- 100MHz host frequency
- Socket 370

Graphics

- Integrated VGA graphics controller and TFT support
 - Connection at front panel
 - Maximum resolution: 1600 x 1200, 8-bit color

Memory

- 32..256MB DRAM
 - One 144-pin SO-DIMM socket for 1Mx64 to 32Mx64 synchronous DRAM modules
 - 100MHz memory bus frequency
- CompactFlash interface
 - Type I and Type II
 - True IDE

Interfaces

- Full-duplex 10/100Mbps/s PCI Ethernet controller
 - 82559(ER) controller
 - 10/100Base-T RJ45 interface at front panel
 - Two display LEDs in RJ45 connector to signal LAN Link and Activity status
 - Supports network boot
- USB (Universal Serial Bus) interface
 - Conforming to Open HCI 1.0a
 - At front panel
 - Data throughput up to 12Mbits/s

PXI

- Two trigger lines compliant with PXI Specification

Mass Storage

- Fast IDE ports
 - One IDE hard-disk/CD-ROM port via 40-pin ribbon cable connector U-DMA66
 - One IDE port for local CompactFlash

I/O Extension

- 4/8HP I/O extension board F7E for standard interfaces at front panel

- For expansion of F7 as a 2-slot 3U, or 1- or 2-slot 6U solution using a special mounting kit
- COM1/COM2 serial (9-pin D-Sub)
- Keyboard/mouse (PS/2)
- LPT parallel (25-pin D-Sub) (only with 8HP I/O extension board)
- U-DMA66 via 44-pin connector
- Floppy disk connection via 34-pin connector
- Connection to F7 via 40-pin IDE and 26-pin LPC connectors
- I/O extension card AD52
 - For expansion of F7 as a 6U solution using a special mounting kit
 - Two serial interfaces (9-pin D-Sub), as RS232 COM1/COM2 or via serial interface adapters for flexible configuration as RS232..TTY
 - Keyboard/mouse (PS/2)
 - LPT parallel (26-pin connector)
 - Connection to F7 via 26-pin LPC connector

Miscellaneous

- Battery-backed real-time clock
- Integrated hardware monitor
- Reset button with "alive" LED at front panel
- Stand-alone operation possible with suitable MEN adapter

Electrical Specifications

- Supply voltage/power consumption:
 - +5V (4.85V..5.25V), 7A (PIII-850MHz), 5.1A (Celeron 600MHz), 6A (Celeron 733MHz)
 - +3.3V (3.2V..3.4V), 3.5A
 - F7E: +5V (4.85V..5.25V), 1.75A max. (+80°C)
- MTBF: 65,500h @ 50°C

Mechanical Specifications

- Dimensions: conforming to CompactPCI specification for 3U boards
- Weight:
 - F7: 324g
 - F7E I/O extension board (4HP): 138g (without hard disk)
 - F7 and AD52 with 6U front panel: 428g

Environmental Specifications

- Temperature range (operation):
 - 0..+60°C or -40..+85°C (depending on processor)
 - Airflow: min. 10m³/h
- Temperature range (storage): -40..+85°C
- Relative humidity (operation): max. 95% non-condensing
- Relative humidity (storage): max. 95% non-condensing
- Altitude: -300m to + 3,000m
- Shock: 15g/0.33ms, 6g/6ms
- Vibration: 1g/5..2,000Hz

Technical Data

Safety

- PCB manufactured with a flammability rating of 94V-0 by UL recognized manufacturers

EMC

- Tested according to EN 55022 / 1999-05 (radio disturbance) and EN 55024 / 1999-05 (immunity) with regard to CE conformity

Software Support

- General Software Embedded BIOS for industrial applications
- Windows NT, Windows 2000/XP, Embedded Windows
- Linux (on request)
- VxWorks
- QNX (on request)
- RTX (on request)

Diagram

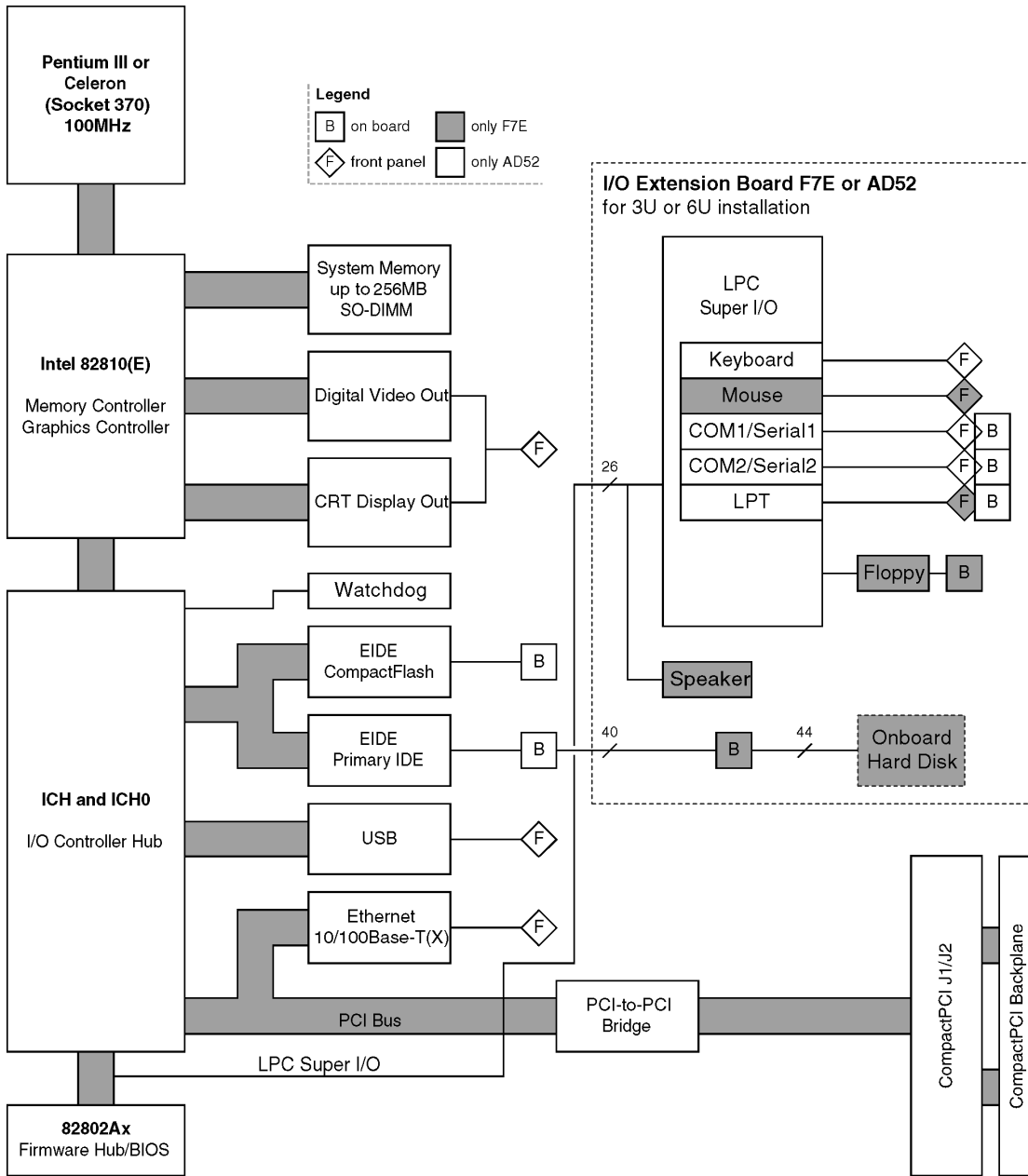

Related Products

Standard Hardware

02F007E00	F7E, I/O extension for F7, keyboard, mouse, serial, parallel, floppy, 3U/8HP (F7 system slot right), 0..+60°C
02F007E01	F7E, I/O extension for F7, keyboard, mouse, serial, parallel, floppy, 3U/8HP (F7 system slot right), -40..+85°C
02F007E02	F7E, I/O extension for F7, keyboard/mouse, 2x serial, floppy, 3U/4HP (F7 system slot right or left), 0..+60°C
02F007E03	F7E, I/O extension for F7, keyboard/mouse, 2x serial, floppy, 3U/4HP (F7 system slot right or left), -40..+85°C
02F007-00	F7, CompactPCI 3U, single-board computer, Celeron 733MHz incl. passive heat sink, 0MB DRAM, 100Mbit Ethernet, DVI graphics, 0..+60°C
02F007-01	F7, CompactPCI 3U, single-board computer, Celeron 733MHz incl. passive heat sink, 64MB DRAM, 100Mbit Ethernet, DVI graphics, -40..+85°C
02F007-02	F7, CompactPCI 3U, single-board computer, Pentium III 850MHz, 0MB DRAM, 100Mbit Ethernet, DVI graphics, 0..+60°C

Please refer to our 3U CompactPCI compare chart for a selection of further single-board computers with different processors and on-board functionality.

Systems & Card Cages

Disk drives for basic systems are delivered as requested. Different rack sizes, power supplies and backplanes on request.

0701-0009	Abk13.10.04 - nur intern; Preis wird nicht erhBuy:offen feexistierende Kunden Last Delivery:offen feexistierende Kunden Name: B.Schmitz Grund: Ersatz-Standardsystem 0701-0021 kann falle 3U-Karten verwendet werden -----CompactPCI 19" 3U rack-mount enclosure, 3U 7-slot CompactPCI backplane, ATX power supply
0701-0018	CompactPCI 19" 4U/84HP rack-mount enclosure for 3U cards (vertical), 8-slot 3U CompactPCI backplane, system slot right, no rear I/O, space for hard-disk drive, floppy drive, 300W ATX power supply wide range 100..240VAC on front, 1U fan tray included

Accessories

05A000-10	Keyboard/mouse Y-cable 0.1m, 6-pin Mini DIN plug to two 6-pin Mini DIN receptacles
-----------	--

Related Products

05F007E00	Hard disk 2.5" installation kit for F7E
05F007N03	Stand-alone adapter for F7 and F7N
05F007-02	DVI-to-VGA cable, DVI plug to 15-pin HD-Sub plug, 2m, -40..+85°C
05F007-03	Adapter, DVI analog plug to VGA 15-pin HD-Sub receptacle, -20..+85°C
05F007-04	6U mounting kit for assembly of F7 + AD52-00/..-01
05F007-05	6U 1Slot mounting kit for assembly of F7 + F7E
05F007-07	6U mounting kit for assembly of F7 + AD52-02/03
0501-0001	DVI-I to DVI-D and VGA Y-adapter cable (for example for D4, F7/N, F8, F9, P17)
You can download the data sheet for hard disk 0710-0012 from MEN's website.	
0710-0009	IDE hard disk 2.5", 9.5mm, 20GB; for mounting on-board (harddisk mounting kit may be additionally required)
0710-0012	Industrial IDE hard disk 2,5", 40GB, 24 hours/7 days, 0..+60°C; for on-board mounting (hard disk mounting kit may be required additionally)
0751-0006	CompactFlash card, 512MB, Type I, 0..+60°C
0751-0007	CompactFlash card, 512MB, Type I, -40..+85°C
0751-0008	CompactFlash card, 64MB, Type I, 0..+60°C
0751-0009	CompactFlash card, 128MB, Type I, 0..+60°C
0751-0012	CompactFlash card, 256MB, Type I, 0..+60°C
0751-0013	Compact Flash card, 64MB, -40..+85°C
0751-0014	Compact Flash card, 128MB, -40..+85°C
0751-0018	CompactFlash card, 256MB, Type I, -40..+85°C
0752-0060	256MB DRAM 0..+60°C for 02F007-02
0752-0066	128MB DRAM 0..+60°C for 02F007-00
0752-0075	64MB DRAM -40..+85°C for 02F007-01
0752-0091	256MB DRAM 0..+60°C for 02F007-00
0752-0098	128MB DRAM -40..+85°C for 02F007-01
0752-0124	256MB DRAM -40..+85°C for 02F007-01
08AD52-00	AD52, adapter for F7: 2x RS232, keyboard/mouse, temperature range: 0..+60°C
08AD52-01	AD52, adapter for F7: 2x RS232, keyboard/mouse, temperature range: -40..+85°C
08AD52-02	AD52, adapter for F7: 2x SA-adapter slots, keyboard/mouse, temperature range: 0..+60°C

Related Products

08AD52-03	AD52, adapter for F7: 2x SA-adapter slots, keyboard/mouse, temperature range: -40..+85°C
08SA01-00	Serial interface adapter, RS232, not optically isolated, 0..+60°C
08SA02-00	Serial interface adapter, RS422/485, half duplex, optically isolated, 0..+60°C
08SA02-01	Serial interface adapter, RS422/485, full duplex, optically isolated, 0..+60°C
08SA02-07	Serial interface adapter, RS422/485, full duplex, optically isolated, temperature range: -40..+85°C
08SA03-00	Serial interface adapter, RS232, optically isolated, 0..+60°C
08SA03-01	Serial interface adapter, RS232, optically isolated, -40..+85°C
08SA04-00	Serial interface adapter, TTY, optically isolated, 0..+60°C

For more functions realized with SA adapters, see the listing on MEN's website. You can also view our SA adapter compare chart for a quick overview of different functions. Please contact sales to make sure that these SA adapters can be used in the board configuration you are looking for.

Software

10F007N61	VxWorks 5.5 / Tornado 2.2 BSP for MEN F7N/F7
10F007-70	

This MEN board is designed to work in a Microsoft Windows environment. For additional Windows driver packages provided or recommended by MEN please refer to the ordering numbers below.

This board is an MEN product running Sysgo's ELinOS Embedded Linux. Sysgo provides full support for MEN hardware. Please contact www.sysgo.de.

QNX software for this MEN board is available from QNX (www.qnx.com). For QNX BSP and driver support provided by MEN please refer to the ordering numbers below.

This board is an MEN product running Linux. For Linux BSP and driver support provided by MEN please refer to the ordering numbers below.

To use MDIS4 low-level drivers, you also need one of the MDIS4 system packages available for Windows, Linux, VxWorks, QNX, RTX or OS-9 (MDIS4 = MEN Driver Interface System).

13Z011-06	MDIS4/2004 low-level driver sources for F7/F7N/D4/EM02 watchdog
13Z011-70	MDIS4/2004 Windows NT4/W2K driver for F7/F7N/D4/EM02 watchdog
14F007-00	BIOS for F7

Documentation

Related Products

20APPN001	Application Note: Using MEN +5V CompactPCI Boards with +3.3V V(I/O)
20F007-00	F7 user manual

For the most up-to-date ordering information and direct links to other data sheets and downloads, see the F7 online data sheet under www.men.de. --> [Click here!](#)

Germany

MEN Mikro Elektronik GmbH
Neuwieder Straße 5-7
90411 Nuremberg
Phone +49-911-99 33 5-0
Fax +49-911-99 33 5-901
E-mail info@men.de
www.men.de

France

MEN Mikro Elektronik SA
18, rue René Cassin
ZA de la Châtelaine
74240 Gaillard
Phone +33 (0) 450-955-312
Fax +33 (0) 450-955-211
E-mail info@men-france.fr
www.men-france.fr

UK

MEN Micro Ltd
Whitehall, 75 School Lane
Hartford, Northwich
Cheshire UK, CW8 1PF
Phone +44 (0) 1477-549-185
Fax +44 (0) 1477-549-178
E-mail info@menmicro.co.uk
www.menmicro.co.uk

USA

MEN Micro, Inc.
PO Box 4160
Lago Vista, TX 78645-4160
Phone (512) 267-8883
Fax (512) 267-8803
E-mail sales@menmicro.com
www.menmicro.com

The date of issue stated in this data sheet refers to the Technical Data only. Changes in ordering information given herein do not affect the date of issue. All brand or product names are trademarks or registered trademarks of their respective holders.

Information in this document has been carefully checked and is believed to be accurate as of the date of publication; however, no responsibility is assumed for inaccuracies. MEN Mikro Elektronik accepts no liability for consequential or incidental damages arising from the use of its products and reserves the right to make changes on the products herein without notice to improve reliability, function or design. MEN Mikro Elektronik does not assume any liability arising out of the application or use of the products described in this document.

The products of MEN Mikro Elektronik are not suited for use in nuclear reactors and for application in medical appliances used for therapeutical purposes. Application of MEN's products in such plants is only possible after the user has precisely specified the operation environment and after MEN Mikro Elektronik has consequently adapted and released the product.

Copyright © 2004 MEN Mikro Elektronik GmbH. All rights reserved.