

2600 SERIES - INSTRUCTION SHEET

The 2600 Series manual preset interval timer is a panel mount design.

MODEL	TIME RANGE	VOLTS	Hz
2605-00	15 min.	120	60
2606-00	30 min.	120	60
2607-00	60 min.	120	60
2608-00	6 hr.	120	60
2609-00	12 hr.	120	60
2610-00	24 hr.	120	60
2607-20	60 min.	208-240	60
2609-20	12 hr.	208-240	60
2610-20	24 hr.	208-240	60

TO PANEL MOUNT 2600 SERIES TIMER



Place timer dial in desired position on panel and mark location of 3 mounting holes and shaft hole. Drill 3/8" dia. center shaft hole and 3 mounting holes 1/4" dia.

Insert timer from back through panel. Position timer dial and insert 3 mounting screws supplied.

Install knob and tighten screw against flat side of shaft. Make certain dial rotates freely. Turn pointer to zero. Switch should click to OFF position.

The HOLD position is a timer feature that allows a load to remain "ON" indefinitely or until manually turned "OFF" by moving pointer to zero position.

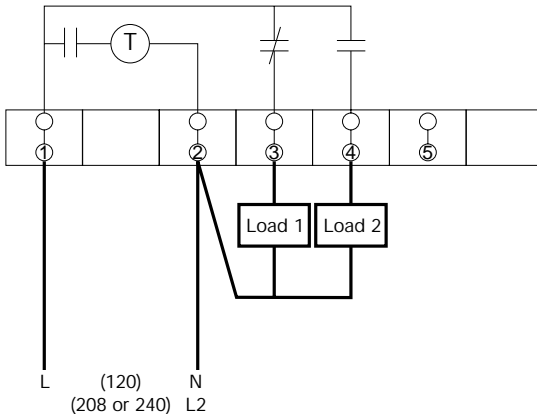

Basic Wiring Diagram

CAUTION:

The 2600 Series Timers are not to be used to control Sun lamps, Sun Tanning Booths, or any application which could result in a personal injury due to over-exposure.



A548 Enclosure -

Available for surface mounting of 2600 series timers

PARAGON
Electrical Products

Maple Chase Company
2820 Thatcher Road
Downers Grove, Illinois 60515
Made in Mexico

An Invensys company

Telephone + 1 800 732 8400
ISO 9002 registered

110-698