

accessories

# **FRL Accessories** *and Options*



# numatics®

---

<b>FRL Accessories &amp; Options</b> .....	3-23
Digital Pressure Sensor/Digital Vacuum Sensor .....	3-6
PS180 Pressure Switches .....	7
PS181 Economy Series Pressure Switches .....	8
PS182 Pressure Switches .....	9
Reclassifiers .....	10
Tank Drain Trap .....	11
Electronic Drain Valves .....	12
Inline Filters - L Series .....	13
Micro-Filtration® Instrumentation Inline Filters .....	14-17
Miniature Manifold Regulator .....	18-19
Oxygen Concentrator Regulator .....	20-21
Gauges .....	22
Mounting Brackets .....	23



### Digital Pressure Sensor/Digital Vacuum Sensor



DPS-180N (left) and DSPG180P (right) pictured

#### Application

Numatics DPS and DVS is a line of digital pressure sensors designed for extremely accurate indication that proper system pressure is being achieved. Available for either vacuum (DVS model) or pressure (DPS model) applications, its highly visible LED display makes it easy to read in either dark or light areas. Other features include quick response (within 2.5ms or less), high repeatability (within 0.2% full scale 1 digit), easy pushbutton setup, and four output process modes which enable versatile pressure level control.

Applications include securing chip-component carriages on a suction hand, controlling of clamp forces, controlling the edge of winding film, verification of frame uniformity, and many more.

#### SPECIFICATIONS

Pressure scale:	Gauge pressure	
Rated pressure range:	Pressure sensor: 0 - 145 PSI; Vacuum sensor: 0 - 14.7 PSI	
Setting pressure range:	Pressure sensor: -0.050 to 1.000 MPa; Vacuum sensor: 5.1 to -101.3 kPa	
Pressure resistance:	Pressure sensor: 1.47 MPa; Vacuum sensor: 490 kPa	
Applicable fluid:	Non-corrosive gas	
Selectable units:	Pressure sensor: kgf/cm <sup>2</sup> , bar, PSI; Vacuum sensor: kgf/cm <sup>2</sup> , bar, PSI, mmHg, InchHg	
Supply voltage:	12 to 24V DC (+10%/-15%) Ripple P-P 10% or less	
Current consumption:	50mA or less	
Comparative output:	NPN open-collector transistor	PNP open-collector transistor
	<ul style="list-style-type: none"> <li>• Max. sink current: 100mA</li> <li>• Applied voltage: 30V DC or less</li> <li>• Residual voltage: 1V or less (@ 100mA sink current)</li> <li>• Residual voltage: 0.4V or less (@ 16mA sink current)</li> </ul>	<ul style="list-style-type: none"> <li>• Max. source current: 100mA</li> <li>• Applied voltage: 30V DC or less</li> <li>• Residual voltage: 2V or less (@ 100mA source current)</li> </ul>
Utilization category:	DC-12 or DC-13	
Output pressure mode:	Selectable with key operation - hysteresis mode, window comparator mode, dual output mode, or automatic setting mode	
Hysteresis:	1 digit (2 digits when using PSI unit, variable when using hysteresis mode)	
Repeatability:	Within ± 0.2% F.S. ± 1 digit	
Response time:	2.5 ms or less	
Short circuit protection:	Incorporated	
Analog voltage output:	Output voltage: 1 to 5V (with rated pressure gauge) Zero-point: Within 1V ± 5%F.S. Span: Within 4V ± 5% F.S. Linearity: Within ± 1% F.S. Output impedance: App. 1kW	
Display:	Red LED display, 3 1/2 digits (sampling cycle: 4 times/sec.)	
Pressure display range:	Pressure sensor: -0.050 to 1.000 MPa; Vacuum sensor: 5.1 to -101.3 kPa	
Analog bar display:	LED-bar step indication every app. 10% F.S.	
Operation indicator		
comparative output 1:	Orange LED (lights up when the comparative output 1 is activated)	
comparative output 2:	Green LED (lights up when the comparative output 2 is activated)	
Environmental resistance		
Pollution degree:	3 (Industrial environment)	
Protection:	IP40 (IEC)	
Ambient temperature:	14° to 122°F (-10° to +50° C) (No dew condensation or icing), Storage: 14° to 140°F (-10° to +60°C)	
Ambient humidity:	35-85% RH, Storage: 35-8% RH	
EMC:	Emission: EN50081-2, Immunity: EN50082-2	
Voltage withstandability:	1,000V AC for 1 minute between all terminals connected and enclosure	
Insulation resistivity:	50kW or more at 500V DC Megger between all terminals connected and enclosure	
Vibration proof:	10-150Hz freq., 0.03 inch (0.75mm) amplitude, and X,Y,& Z directions each for 2 hours (unenergized)	
Shock proof:	100m/s <sup>2</sup> acceleration (app. 10G), and X,Y,& Z directions each for three times (unenergized)	
Temperature characteristic:	Within ±1% F.S. of detection pressure at 68°F (20°C) in 14°-122°F (-10°-+50°C) temp. range	
Material:	Front case: ABS; rear case: PPS (containing glass fiber); display surface: acrylic; press. port attachment: die-cast zinc alloy	
Cable:	Oil-resistant cabtyre cable 6.5 feet (2m) long w/ 5 0.15mm <sup>2</sup> conductors	
Cable extension:	Max. extension is 328 feet (100m) overall with an equivalent cable with conductors 0.3 mm <sup>2</sup> or more	
Weight:	NPT/BSPT: 3.35 oz (95g); BSPP: 4.23 oz (120g)	



## Digital Pressure Sensor/Digital Vacuum Sensor – Model Selection

### 2 Meter Pigtail Cable

PRESSURE SENSOR (0-145PSI;0-1.000MPa)		VACUUM SENSOR (0 to -14.5PSI;0 to -101.3 kPa)	
MODEL	DESCRIPTION	MODEL	DESCRIPTION
DPS-180N	NPN (sinking) 1/8 NPTF Base	DVS-180N	NPN (sinking) 1/8 NPTF Base
DPS-180P	PNP (sourcing) 1/8 NPTF Base	DVS-180P	PNP (sourcing) 1/8 NPTF Base
DPSG180N	NPN (sinking) 1/8 BSPP Base	DVSG180N	NPN (sinking) 1/8 BSPP Base
DPSG180P	PNP (sourcing) 1/8 BSPP Base	DVSG180P	PNP (sourcing) 1/8 BSPP Base
DPSR180N	NPN (sinking) 1/8 BSPT Base	DVSR180N	NPN (sinking) 1/8 BSPT Base
DPSR180P	PNP (sourcing) 1/8 BSPT Base	DVSR180P	PNP (sourcing) 1/8 BSPT Base

\* For NPTF flatback design as shown on BSPP models add an "F" to model number (Ex: DPS-180PF)

### 8 Inch Lead, 8 mm Pico Connector

PRESSURE SENSOR (0-145PSI;0-1.000MPa)		VACUUM SENSOR (0 to -14.5PSI;0 to -101.3 kPa)	
MODEL	DESCRIPTION	MODEL	DESCRIPTION
DPS-180N-1	NPN (sinking) 1/8 NPTF Base	DVS-180N-1	NPN (sinking) 1/8 NPTF Base
DPS-180P-1	PNP (sourcing) 1/8 NPTF Base	DVS-180P-1	PNP (sourcing) 1/8 NPTF Base
DPSG180N-1	NPN (sinking) 1/8 BSPP Base	DVSG180N-1	NPN (sinking) 1/8 BSPP Base
DPSG180P-1	PNP (sourcing) 1/8 BSPP Base	DVSG180P-1	PNP (sourcing) 1/8 BSPP Base
DPSR180N-1	NPN (sinking) 1/8 BSPT Base	DVSR180N-1	NPN (sinking) 1/8 BSPT Base
DPSR180P-1	PNP (sourcing) 1/8 BSPT Base	DVSR180P-1	PNP (sourcing) 1/8 BSPT Base

\* For NPTF flatback design as shown on BSPP models add an "F" to model number (Ex: DPS-180P-1F)

### 8 Inch Lead, 12 mm Micro Connector

PRESSURE SENSOR (0-145PSI;0-1.000MPa)		VACUUM SENSOR (0 to -14.5PSI;0 to -101.3 kPa)	
MODEL	DESCRIPTION	MODEL	DESCRIPTION
DPS-180N-2	NPN (sinking) 1/8 NPTF Base	DVS-180N-2	NPN (sinking) 1/8 NPTF Base
DPS-180P-2	PNP (sourcing) 1/8 NPTF Base	DVS-180P-2	PNP (sourcing) 1/8 NPTF Base
DPSG180N-2	NPN (sinking) 1/8 BSPP Base	DVSG180N-2	NPN (sinking) 1/8 BSPP Base
DPSG180P-2	PNP (sourcing) 1/8 BSPP Base	DVSG180P-2	PNP (sourcing) 1/8 BSPP Base
DPSR180N-2	NPN (sinking) 1/8 BSPT Base	DVSR180N-2	NPN (sinking) 1/8 BSPT Base
DPSR180P-2	PNP (sourcing) 1/8 BSPT Base	DVSR180P-2	PNP (sourcing) 1/8 BSPT Base

\* For NPTF flatback design as shown on BSPP models add an "F" to model number (Ex: DPS-180P-2F)

Note: See accessories on page 5-6.

### Female Single Ended Cordset

CONNECTOR TYPE	CONNECTOR STYLE	CONNECTOR LENGTH	MODEL NUMBER
M8 Pico	Straight	2 Meters	DPS-08-02-ST
M8 Pico	Straight	5 Meters	DPS-08-05-ST
M12 Micro	Straight	2 Meters	DPS-12-02-ST
M12 Micro	Straight	5 Meters	DPS-12-05-ST



### Digital Pressure Sensor/Digital Vacuum Sensor Dimensions

#### NPTF/BSPT model

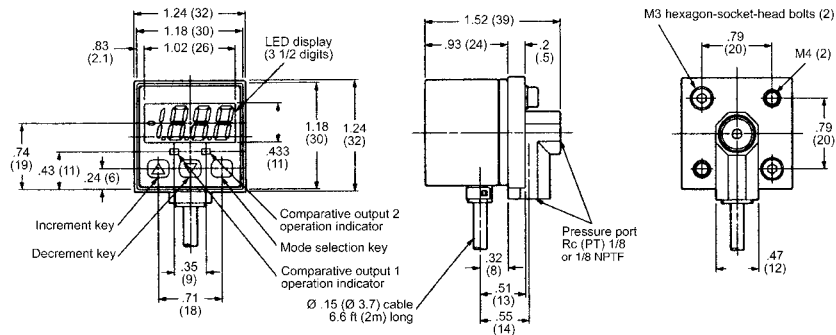

#### BSPP model

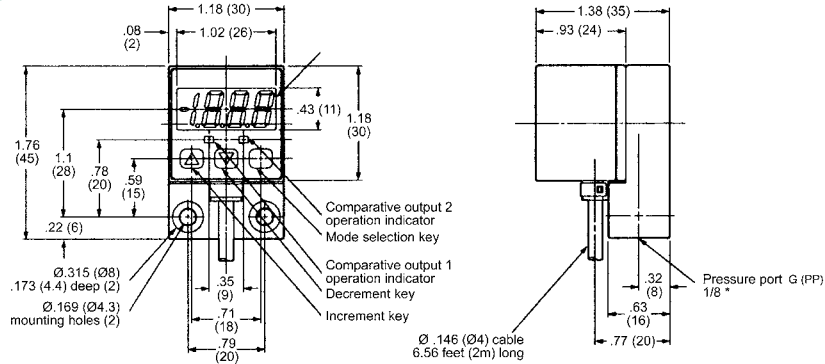

#### Mounting Bracket\* (UZU811)

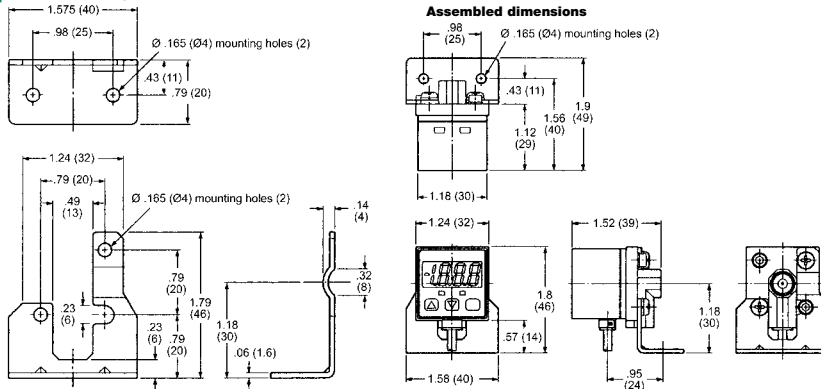

#### Panel Mounting Bracket with Protective Cover\*

(Panel mounting bracket: UZU812; Front protective cover: UZU813)

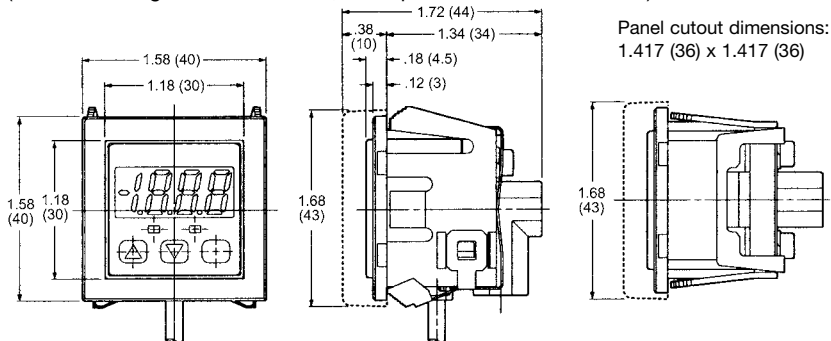

In inches (millimeters in parenthesis)



### Digital Pressure Sensor/Digital Vacuum Sensor – Options (NPTF & BSPT models only)

#### Panel Mounting Bracket and Front Protective Cover

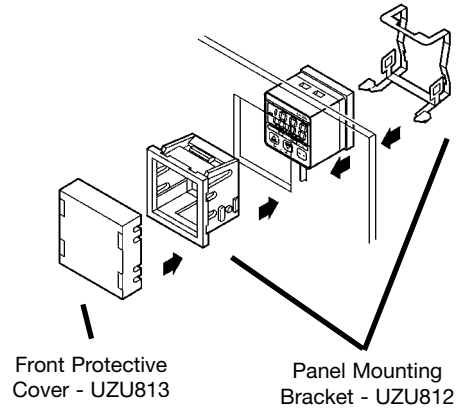

NOTE: Front protective cover used with panel mounting bracket cannot be used alone.

#### Sensor Mounting Bracket

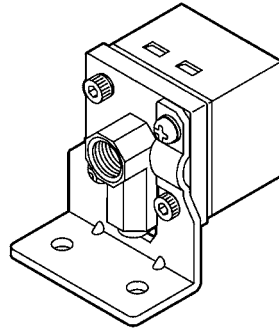

Part # UZU811  
Two M4 pan head screws and two spring washers included.





### PS180 Pressure Switches

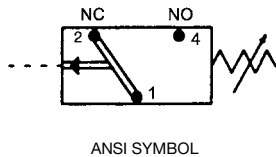

#### Application

Numatics PS180 is a line of pressure switches designed for accurate indication that proper system pressure is being achieved. Available in 1/8 or 1/4 threads, it is easily incorporated into an air system using a **FLEXIBLOK®** diverter plate of other manifold.

Featuring a rugged housing made from zinc coated steel, the PS180 is designed for industrial multi-million cycle life applications. The four pin connector plug is included and contains a key way preventing accidental misconnection. Pressure adjustment is tamper resistant, hindering unauthorized changes. It can be wired in either normally open or normally closed configurations and includes a case ground pin.

#### Specifications

Contact Rating: 4A @ 250 V AC  
 Protection: IP 65, terminals IP00  
 Maximum Operation: 200/min  
 Temperature Range: 0° F to 190° F (-15° C to 85° C)  
 Maximum Pressure: 300 PSI (20 bar)  
 Maximum Voltage: 250 V AC (200 DC)  
 Hysteresis Adjustment: 15%  
 Connector Material: polyamid  
 Diaphragm Material: Buna N  
 Housing Material: zinc plated steel

#### Dimensions in inches (millimeters in parenthesis)

##### NPTF Thread Dimensions

MODEL	A	B	C
PS180BAN01	2.5 (64)	1.0 (27)	3.1 (79)
PS180CAN01	2.5 (64)	1.0 (27)	3.1 (79)
PS180BAN02	2.5 (64)	1.0 (27)	3.1 (79)
PS180CAN02	2.5 (64)	1.0 (27)	3.1 (79)

##### BSPP Thread Dimensions

MODEL	A	B	C
PS180BAG02	2.3 (58)	1.0 (27)	2.9 (74)
PS180CAG02	2.3 (58)	1.0 (27)	2.9 (74)

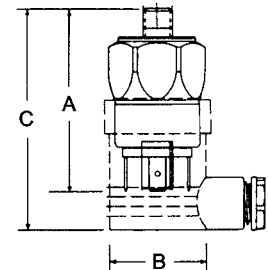

#### NPTF Thread Model Selection

NPTF	MODEL	PSIG (BAR)
1/8	PS180BAN01	4-20 (.3-1.5)
1/8	PS180CAN01	14-150 (1-10)
1/4	PS180BAN02	4-20 (.3-1.5)
1/4	PS180CAN02	14-150 (1-10)

#### BSPP Thread Model Selection

BSPP	MODEL	PSIG (BAR)
1/4	PS180BAG02	4-20 (.3-1.5)
1/4	PS180CAG02	14-150 (1-10)

Use "G" suffix for gold plated terminals (for applications below 50 mA), i.e. PS180BAN02G



## PS181 Economy Series Pressure Switches



### Application

Numatics PS181 is the most economical of the Numatics Pressure Switch line. Available in 1/8 or 1/4 NPT and BSPP threads, it is easily incorporated into an air system using a FlexiBlok diverter plate or diverter block.

Unlike the PS180 Switch, which uses a plug mount for the electrical connection, the PS181 directly connects to the body mounted terminals. Pressure adjustment is tamper resistant, hindering unauthorized changes. It can be wired in either a normally open or normally closed configuration.

### Specifications

Hysteresis Adjustment	15%
Pressure Ranges:	4 - 20, 14-150 psi
Max Pressure:	300 psi
Set Point Tolerance:	+/- 1 Psi or 5%
*Contact Rating:	4A @ 250 V AC
Diaphragm Material:	Buna N
Max Operating Cycles:	200/min
Temperature Range:	0 to 190 F (-15 to 85 C)
Maximum Voltage:	250 V AC
Sealing/Protection:	IP 65, terminals IP 00
Housing Material:	Zinc Plated Steel
Connector Material:	Polyamide

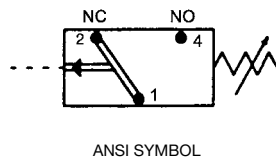

### Dimensions in inches (millimeters in parenthesis)

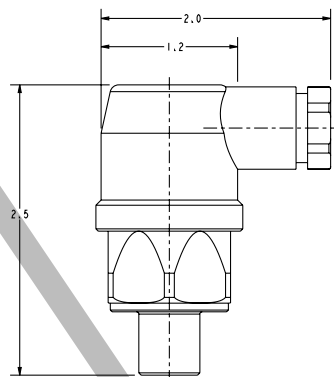

### NPTF Thread Model Selection

NPTF	MODEL	PSIG (BAR)
1/8	PS181BAN01	4-20 (0.3-1.5)
1/8	PS181CAN01	14-150 (1-10)
1/4	PS181BAN02	4-20 (0.3-1.5)
1/4	PS181CAN02	14-150 (1-10)

### BSPP Thread Model Selection

BSPP	MODEL	PSIG (BAR)
1/4	PS181BAG02	4-20 (0.3-1.5)
1/4	PS181CAG02	14-150 (1-10)

**PS181 Switch All Models No Longer Available  
Replaced By PS182 Switches Next Page**





### PS182 Pressure Switches

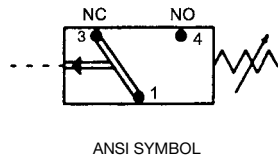

#### Application

Numatics PS182 is the most rugged of the Numatics Pressure Switches. Available in 1/8 or 1/4 NPT and BSPP threads, it is easily incorporated into an air system using a FlexiBlok diverter plate or diverter block.

The unique 12 mm, micro connector makes it simple for electrical connection. The knurled knob with tamper resistant hex screw makes it the easiest pressure adjustment on the market. It can be wired in either a normally open or normally closed configuration.

#### Specifications

Hysteresis Adjustment	10%
Pressure Ranges:	2-10, 6-30, 20-130
Max Pressure:	600 psi
Set Point Tolerance:	+/- 1 Psi or 5%
*Contact Rating:	4A
Diaphragm Material:	Buna N
Max Operating Cycles:	200/min
Temperature Range:	-40 to 250 F (-40 to 121 C)
Voltage Range:	12 V DC to 250 V AC
Sealing/Protection:	IP 65
Housing Material:	Brass
Electrical Connection:	3-Pin Micro (12 mm)

\*Comes standard with gold plated contacts.

#### Dimensions in inches (millimeters in parenthesis)

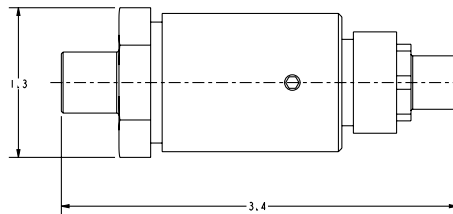

#### NPTF Thread Model Selection

NPTF	MODEL	PSIG (BAR)
1/8 NPT	PS182AAN01	2-10 (0.14-0.69)
1/8 NPT	PS182BAN01	6-30 (0.40-2.07)
1/8 NPT	PS182CAN01	20-130 (1.38-8.96)
1/4 NPT	PS182AAN02	2-10 (0.14-0.69)
1/4 NPT	PS182BAN02	6-30 (0.40-2.07)
1/4 NPT	PS182CAN02	20-130 (1.38-8.96)

#### BSPP Thread Model Selection

BSPP	MODEL	PSIG (BAR)
1/8 BSPP	PS182AAG01	2-10 (0.14-0.69)
1/8 BSPP	PS182BAG01	6-30 (0.40-2.07)
1/8 BSPP	PS182CAG01	20-130 (1.38-8.96)
1/4 BSPP	PS182AAG02	2-10 (0.14-0.69)
1/4 BSPP	PS182BAG02	6-30 (0.40-2.07)
1/4 BSPP	PS182CAG02	20-130 (1.38-8.96)

#### Female Single Ended Cordset

CONNECTOR TYPE	CONNECTOR LENGTH	MODEL NUMBER
90° Elbow	5 Meters	PS182-5-90
Straight	5 Meters	PS182-5-ST



## Numatics FRL Accessories and Options

### Reclassifiers



H40-08 pictured

#### Application

The Numatics Reclassifier is an exhaust coalescing filter/silencer. Its design removes oil mist and reduces noise from exhaust ports on pneumatic air valves, cylinders, and air control systems at extremely high flow rates.

The Numatics Reclassifier can be mounted to exhaust ports on any valve or manifold using a common exhaust base or by combining exhaust ports. Mounting it vertically fully utilizes the oil-catching sump surrounding the filter element and provides easy draining.

#### Features

- 99% oil removal efficiencies
- 25 dBA noise reduction
- high exhaust flow rates
- low differential back pressures
- top performer in automated paint systems
- 1 micron filtration
- manual or continuous drain option
- metric threads available

#### Specifications

Maximum temperature: 125° F (52° C) CV rating (30 Series): 6  
 Maximum pressure: 100 PSIG (7 bar) CV rating (40 Series): 10

#### Air Flow vs. Back Pressure

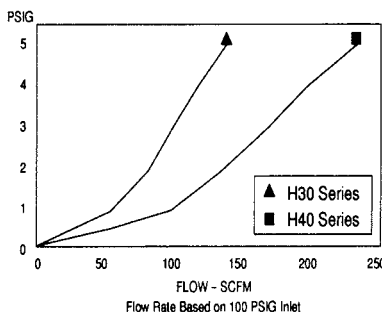

#### Air Flow vs. Sound Level

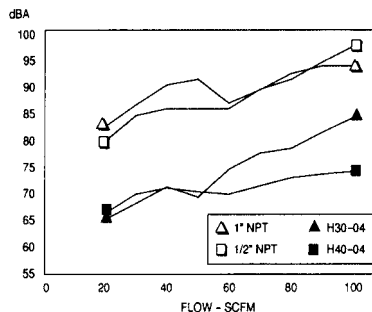

### Reclassifiers

#### ► Element Replacement Kits

includes filter element only

kit #	description
EKF30H	30 Series, 1 micron coalescer
EKF40H	40 Series, 1 micron coalescer

#### ► Bowl Replacement Kits

includes bowl and o-ring

kit #	description
BKF30	30 Series, polycarbonate bowl
BKF30C	30 Series, CircleVision™ bowl
BKF30M	30 Series, metal bowl
BKC40	40 Series, polycarbonate bowl

#### Dimensions

top dimensions = inches  
 bottom dimensions (in parenthesis) = millimeters

MODEL	A	B
H30-04	2.5 (64)	7 (178)
H30-06	2.5 (64)	7 (178)
H40-08	3.75 (95)	7.245 (184)
H40-10	3.75 (95)	7.245 (184)

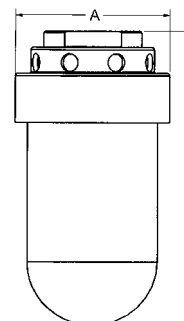

### How to Order

**H 30 - 04 M**

#### Threads

- = NPTF
- G = G Tap (BSPP)

#### Options

- C = CircleVision™ Sight Bowl
- M = Metal Bowl

#### Port Size

- 04 = 1/2
- 06 = 3/4

**H 40 - 08**

#### Port Size

- 08 = 1
- 10 = 1-1/4

#### Threads

- = NPTF
- G = G Tap (BSPP)



### Tank Drain Trap



J30-06CH pictured

#### Application

The Numatics Heavy Duty Tank Drain Trap is designed to automatically expel condensed moisture and compressor carryover liquids with a float design from compressed air systems, without the use of electricity, whenever liquids accumulate.

#### Features

- CircleVision™ bowl allows 360° view
- Heavy duty drain prevents clogging
- Pushbutton manual override

#### Specifications

Maximum Pressure: 250 PSIG (17 bar)  
 Minimum Pressure: 30 PSIG (2 bar)  
 Bowl Capacity: 8.5 oz

#### Dimensions

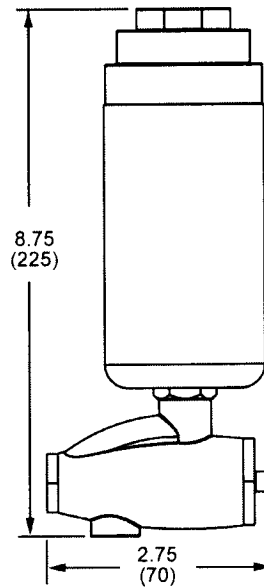

### How to Order

J 30 - 04 C H

Port Size  
 04 = 1/2  
 06 = 3/4

Threads  
 - = NPTF  
 G = G Tap (BSPP)



## Numatics FRL Accessories and Options

# NUMATICS®

### Electronic Drain Valves



EDV-04-110AC pictured

#### Application

Eliminate the manual draining of air lines with the EDV Series Electronic Drain Valve from Numatics. The EDV Series valve is designed to remove condensation from filters, receiver tanks, separators, drip legs, drain traps, and dryers in electronically controlled intervals. The EDV valve is available in 1/4, 3/8, and 1/2 sizes. The large orifice allows even the largest rust and pipe scale particles to be easily expelled. Standard model includes a 110 volt AC solenoid, 6 ft (2 m) power cord, and grounded plug. An EDV valve can be installed virtually anywhere.

#### Specifications

##### Valve

- Function: 2 way, NC, solenoid valve
- Valve Design: pilot operated diaphragm valve
- Port Sizes: 1/4, 3/8
- Orifice: 5/16" (8mm) 1.12 Cv 1/2" (12mm) 2.45 Cv
- Operating Pressure: 20-300 PSIG (1.3-20 bar)
- Solenoid: continuous duty
- Mounting: any position
- Body Material: brass

##### Timer

- Material: plastic polyamid
- Interval Timer: 1-45 min.
- 'On' Timer: .25-25 sec
- Voltage: 12-230 V AC/DC
- Frequency: 50/60 Hz
- Power Rating: 10 watt
- Enclosure: NEMA 4 / IP65
- Ambient Temp: 130° F (55° C)

##### Lights

- Left Indicator: power on
- Right Indicator: solenoid engaged

#### Dimensions

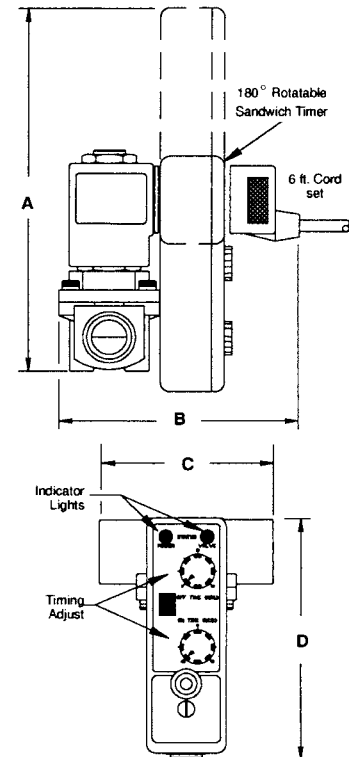

PORT SIZE	A	B	C	D
1/4,3/8	5.75 (146)	3.5 (89)	2.25 (57)	3.75 (95)
1/2	6.0 (152)	3.5 (89)	2.75 (70)	3.75 (95)

dimensions in inches (millimeters in parentheses)

### How to Order

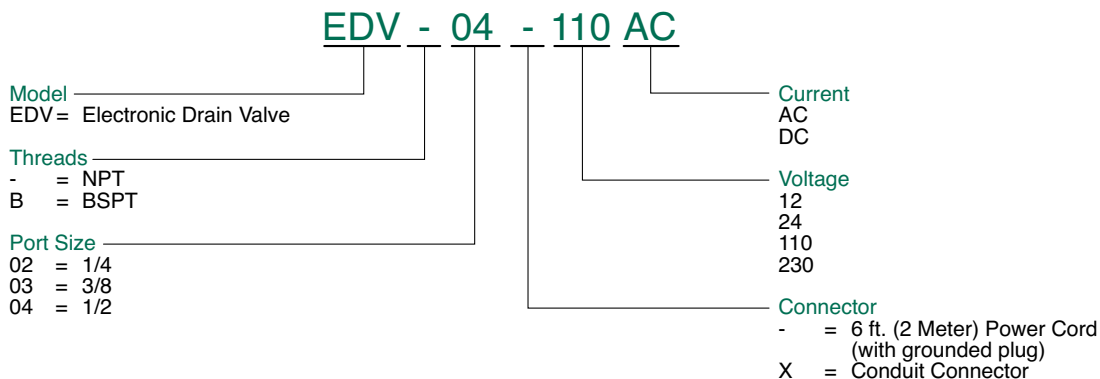



### Inline Filters

#### L Series

L Series in-line filters are designed to protect small air tools such as grinders, impact wrenches, nut runners, screwdrivers or pneumatic components. It will extend component life and reduces downtime by preventing foreign particles from entering the tool. Therefore eliminating expensive tool repair.

Its compact and lightweight anodized aluminum body can be easily installed directly inline before the tool or component.

L Series inline filters can also be used in low-pressure hydraulic applications. They can remove debris or contaminants, hence decrease tool wear and improve system efficiency. The 40-micron filter element insures minimum pressure drop and can be easily replaced or cleaned.

#### Drawings

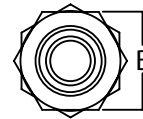
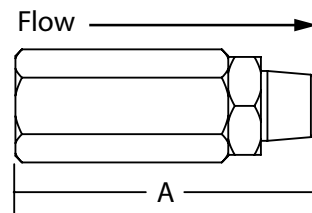

#### ANSI Symbol

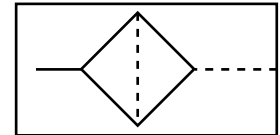

### Specifications

Model	L1MN	L2MN	L3MN	L4MN	L5MN
Port Size	1/8"	1/4"	3/8"	1/2"	3/4"
Overall Length (A)	2-3/16"	2-3/16"	2-5/16"	3-13/16"	3-7/8"
HEX (B)	3/4"	3/4"	7/8"	1-1/2"	1-1/2"
Material	Anodized Aluminum				
	Element: Sintered Bronze (40 micron standard)				
MAX Operating Pressure	300 PSI (21.1 ig./cm <sup>2</sup> )				
Operating Temperature	35~200°F (1.6~93.3°C)				

### Flow

Flow is based on 100 psi inlet and the Delta P shown below.

Model		5 PSID	4 PSID	3 PSID	2 PSID	1 PSID
L1MN	Flow SCFM	21	19	18	13	6
L2MN	Flow SCFM	37	24	20	15	10
L3MN	Flow SCFM	33	26	24	19	10
L4MN	Flow SCFM	150	95	80	50	20
L5MN	Flow SCFM	195	188	165	130	25

### Element Kits

L1, L2, L3 MN	EKL123
L4, L5 MN	EKL45



**MICRO-FILTRATION®** PL Series (Miniature Inline Series)



PLS-B pictured

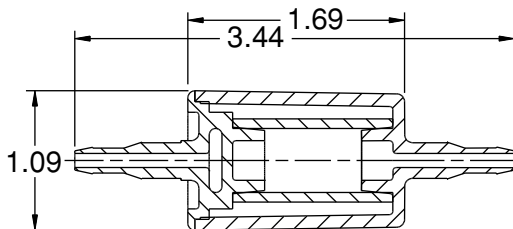

PLS-T pictured

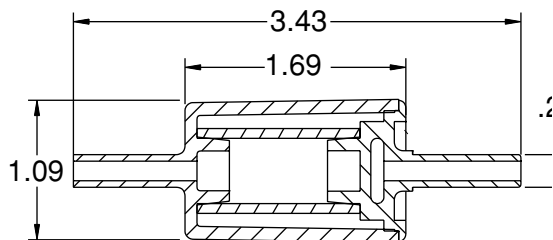

Features

- Max pressure at 125 PSI (8.6 BAR)
- Max temperature at 125°F (52° C)
- Rugged polyurethane housing with dual barbs
- Compatible with many chemicals
- Depth-loading media provides long life
- Dual barb for 1/4 and 1/8 ID soft tubing
- "D" option for indication of oil in system

Applications

- Sensor Protection
- Pneumatic Logic
- Exhaust Muffler
- Medical/ Pharmaceutical

Flow Rates for PLS-B

Pressure PSIG	10	20	40	60	80	100	125
(BAR)	(0.68)	(1.37)	(2.75)	(4.13)	(5.51)	(6.89)	(8.62)
Flow (SCFM*)	0.7	1	1.5	1.9	2.4	3	3.5

\* Based on a 1.5 psid pressure drop

Features

- Max pressure at 125 PSI (8.6 BAR)
- Max temperature at 125°F (52° C)
- Rugged nylon housing
- Straight tang for push-on fittings
- Depth-loading media provides long life

Applications

- Sensor Protection
- Pneumatic Logic
- Exhaust Muffler
- Medical/ Pharmaceutical

Flow Rates for PLS-T

Pressure PSIG	10	20	40	60	80	100	125
(BAR)	(0.68)	(1.37)	(2.75)	(4.13)	(5.51)	(6.89)	(8.62)
Flow (SCFM)	0.9	1.2	2	2.5	3.2	3.8	4.6

\* Based on a 1.5 psid pressure drop

How to Order

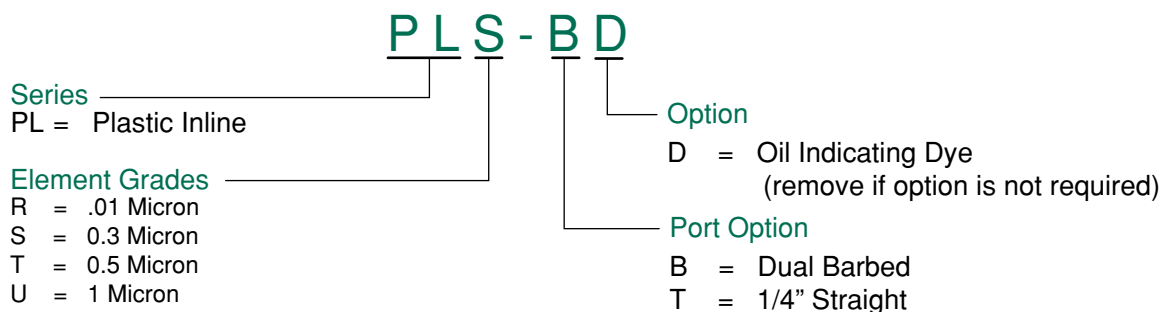





### MICRO-FILTRATION® PT Series (Miniature Inline Series)



PTS-B pictured

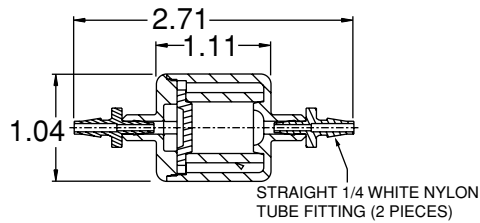

PTS-BN pictured

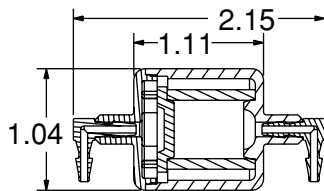

#### Features

- Max pressure at 35 PSI (2.5 BAR)
- Max temp at 125° F (52° C)
- Rugged blue tinted nylon housing
- Straight barb option
- Depth-loading media provides long life

#### Applications

- Protection of miniature pneumatic components
- Sampling devices
- Small design areas
- Exhaust muffler

#### Flow Rates for PTS-B

Pressure PSIG	5	10	20	35
(BAR)	(0.34)	(0.68)	(1.37)	(2.41)
Flow (SCFH*)	20	25	28	38

\* Based on a 1.5 psid pressure drop

#### Features

- Max pressure at 35 PSI (2.5 BAR)
- Max temp at 125° F (52° C)
- Rugged blue tinted nylon housing
- Right angle barb option
- Depth-loading media provides long life

#### Applications

- Protection of miniature pneumatic components
- Sampling devices
- Small design areas
- Exhaust muffler

#### Flow Rates for PTS-BN

Pressure PSIG	5	10	20	35
(BAR)	(0.34)	(0.68)	(1.37)	(2.41)
Flow (SCFH*)	18	23	26	35

\* Based on a 1.5 psid pressure drop

### How to Order

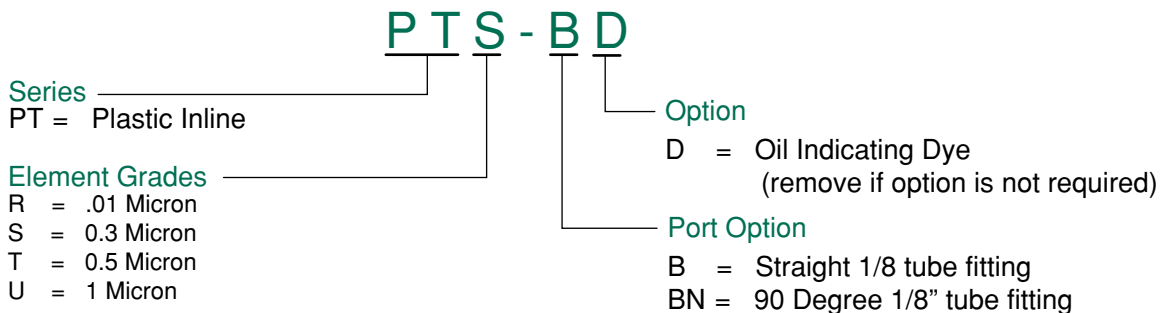



**MICRO-FILTRATION®** PHD Series



Features

- Max pressure 100 PSIG (7 BAR)
- Max temp 200°F (93°C)
- 300°F at 60 PSIG (4 BAR) (11°C)
- Rugged Polyester housing
- Brass inserts
- Inner support core which protects element from collapsing
- Spin welded seal - no adhesives or chemicals
- Thermally bonded end caps on elements
- Extended version for longer filter life

Applications

- Medical concentrators
- Intake filter
- After filter for miniature desiccant beds
- High flow pneumatic tools
- Critical instrumentation protection

Flow Rates

Pressure PSIG (BAR)	10 (0.68)	20 (1.3)	40 (2.7)	60 (4.1)	80 (5.5)	100 (6.8)
PH*-02* Flow (SCFM*)	10	12.5	17	20	21	26
PX*-02* Flow (SCFM*)	12	15	19	23	26	30

\* Based on a 1.5 psid pressure drop

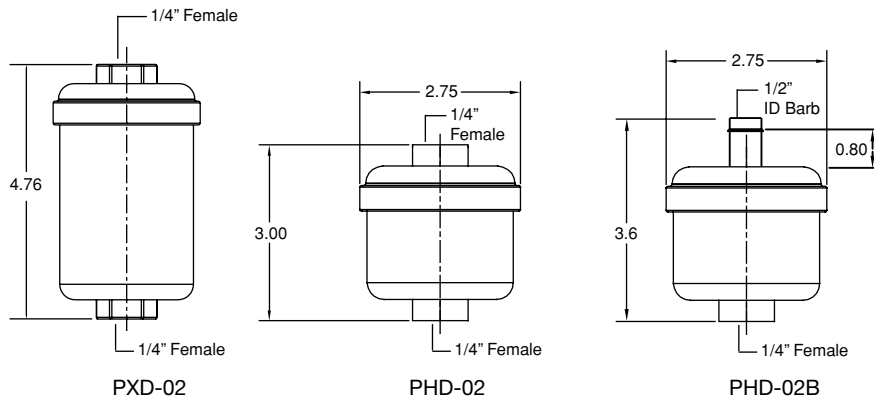

How to Order

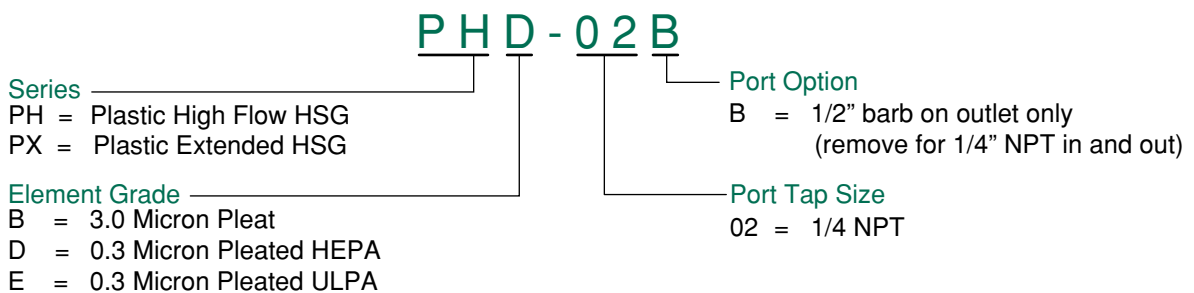



### MICRO-FILTRATION® MF Series (Miniature Inline Series)



MF05D-02 pictured

#### Features

- Aluminum construction
- Replaceable element
- Max pressure 150 PSIG (10 BAR)
- Max temp 200°F (111°C)
- Compact design
- Miniature coalescing capability

#### Applications

- Miniature air tools
- Abusive applications
- Control panels
- Outdoor applications

#### Flow Rates for MF

Pressure PSIG	10	20	40	60	80	100	150
(BAR)	(0.68)	(1.37)	(2.75)	(4.13)	(5.51)	(6.89)	(10.34)
Flow (SCFM*)	1.5	2.1	3.3	4.6	5.8	7	10

\* Based on a 1.5 psid pressure drop

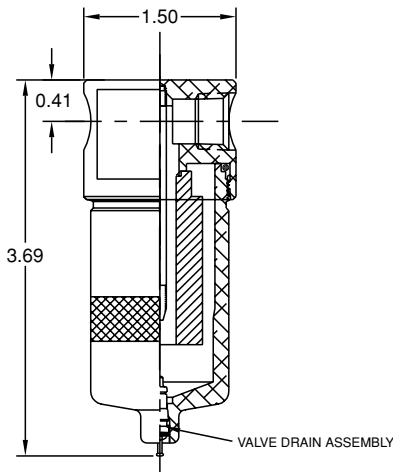

### How to Order

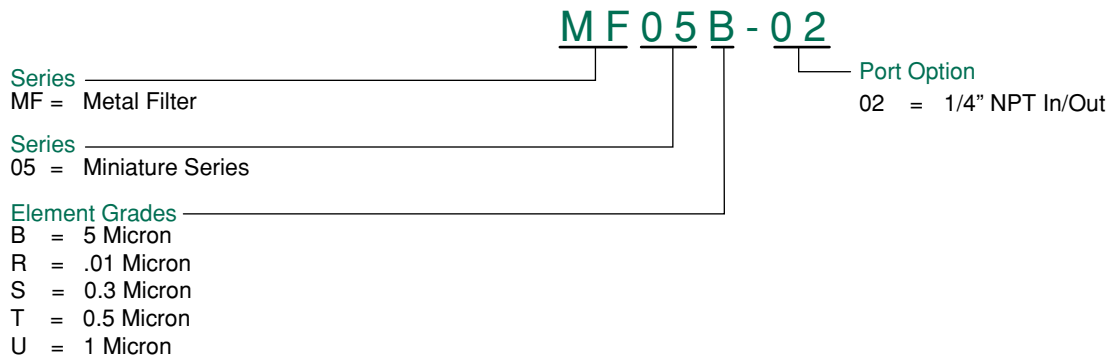



## Numatics FRL Accessories and Options

### Miniature Manifold Regulator MR02 Series



MR02R-01G pictured  
shown assembled and individually

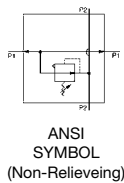
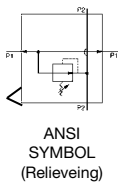

#### Application

The MR02 Series Miniature Manifold Regulator offers the flexibility necessary for many of today's applications. The MR02 Series allows several regulators to be chained together while maintaining a constant primary pressure to each regulator.

A system equipped with the Miniature Manifold Regulator can help reduce operation costs by reducing unnecessary downstream pressures and improve efficiencies by keeping them in one, convenient location for easy adjustment.

#### Features

- Can be installed as an individual or manifold unit
- Standard output pressure 0 -125 PSIG
- 3 available outlet/gauge ports (one in front, one in back, and one in the bottom)
- Integral mounting holes allow for easy panel mounting
- Connects easily without adapters or independent manifold system
- Standard 5 mm tamper resistant adjustment
- High flow capability in relation to compact size (2.7" height x 1" square)
- Relieving or non-relieving models

#### Specifications

P1 Ports: 1/8 NPTF  
 Outlet/Gauge Ports: 10-32 UNF  
 Temperature Range: 40 -120 F (4-50 C)  
 Max Inlet Pressure: 200 PSIG (14 Bar)  
 Weight: .15 lbs (68 grams)  
 \*\*SCFM w/100 PSI inlet set @ 75: 5 scfm  
 \*\*SCFM w/100 PSI inlet set @ 60: 4 scfm  
 \*\*SCFM w/100 PSI inlet set @ 40: 3 scfm  
 Body material: Aluminum

\*\* based on a 25% pressure drop from set

#### Optional Accessories

ITEM	PART NO.
23mm Gauge "G" Option	NG23-M
10-32 - 1/8 NPTF Adapter	134-034
10-32 - 1/8 O.D Barb Fitting	134-236
10-32 - 1/4 O.D Barb Fitting	134-234

Each Regulator includes an R02K assembly kit which includes (1) 10-32 pipe plug, (1) 1/8 pipe plug, (1) P1 port o-ring, (2) connector screws

### How to Order

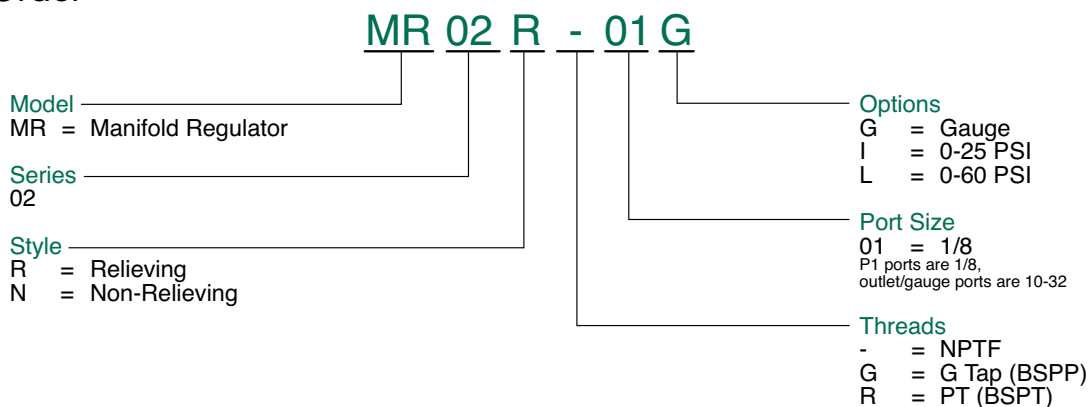



### Miniature Manifold Regulator

MR02 Series

#### Product Cross Section

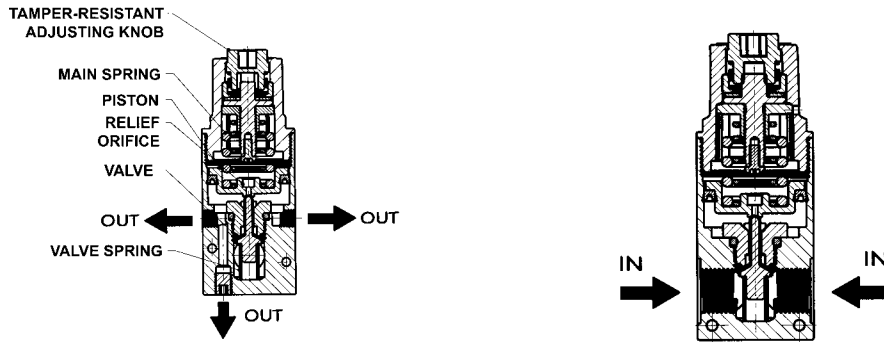

#### Dimensions

TOP



BOTTOM

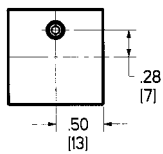

FRONT

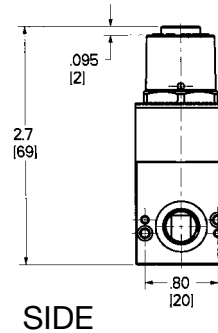
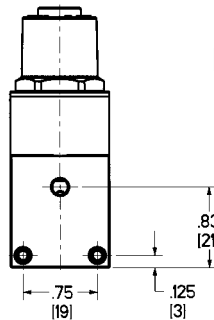

#### Flow Ratings

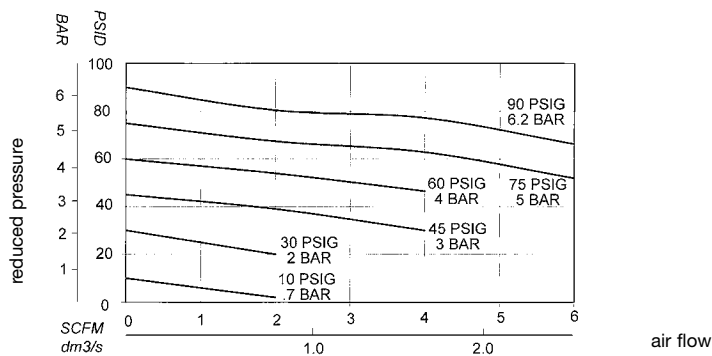



## Numatics FRL Accessories and Options

# NUMATICS®

### Oxygen Concentrator Regulator



#### Application

The 03 series specialty miniature regulator is designed for applications requiring precision control at a very low cost. Used primarily in OEM applications, the 03 series can be applied in applications using air, nitrogen, oxygen, water, and other inert gases/fluids. Its lightweight all plastic design allows use in many specialty environments. This regulator has been applied successfully in many different markets including:

Oxygen: concentrators, analyzers, anesthesia

Adhesive: Applicators, metering equipment

Paint: spray systems, head control

Water service: filtration, control, aeration

Test equipment: leak test, air gauging, flow test

#### Features

- Flows accurate to 0.1 psi in low flow applications
- Four spring ranges available as a standard. 0-15 psi, 0-30 psi, 0-60 psi, 0-100psi.
- Relieving or non relieving models.
- Tamper-resistant or adjustable designs available.

- Body Design Features

#### 101 / 102 series

- Barb fitting outlet designed for use with 1/4 inch id tubing allows fast assembly.
- Threaded 1/8 supply is male eliminates extra fitting.
- Tamperproof or preset knob.

#### 201 / 202 series

- Barb fitting outlet designed for use with 1/8 inch id tubing allows fast assembly.
- Manifold inlet and outlet ports.
- Quick assembly with fixed height dimension.
- Tamperproof or preset knob.

#### Specifications

Temperature Range: 40-120F (4-50C)

Max inlet Pressure: 150 PSIG (10bar)

Weight:

SCFM with 100psi inlet set at 75 psi: 70 lpm

SCFM with 100psi inlet set at 60 psi: 50 lpm

SCFM with 100psi inlet set at 40 psi: 30 lpm

SCFM with 100psi inlet set at 10 psi: 10 lpm

Body Material: Delrin

Dimensions in inches (millimeters in parenthesis)

R03N-101

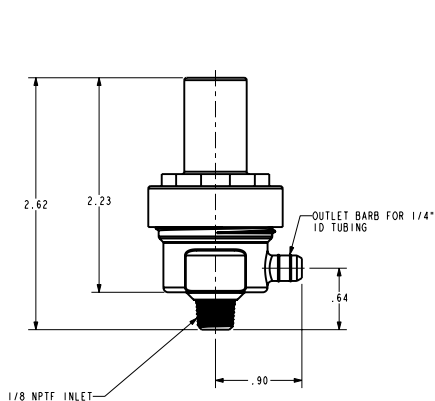

R03N-102

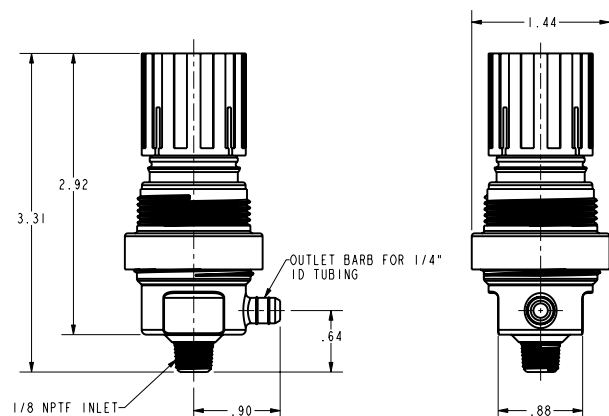





### Oxygen Concentrator Regulator

Dimensions in inches (millimeters in parenthesis)

R03N-201

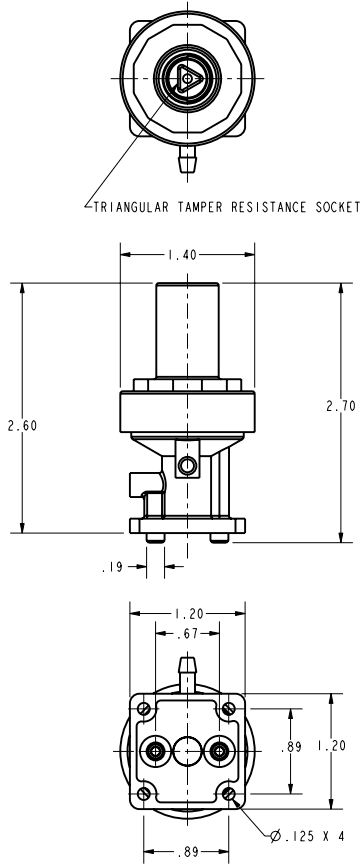

R03N-202

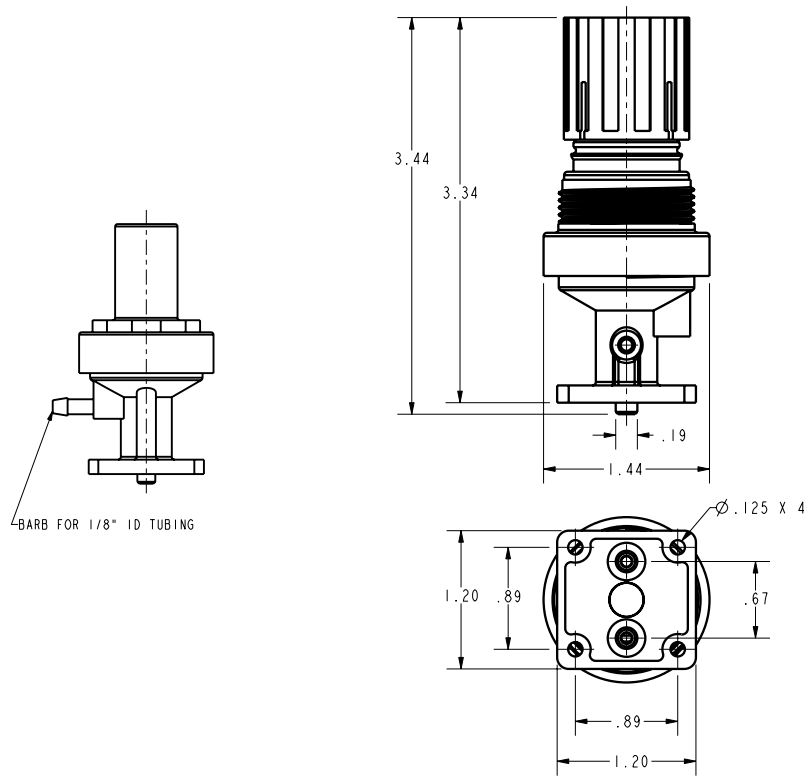

### How to Order

	<b>R03 N - 101</b>	
<b>Series</b>	_____	<b>Model</b>
Oxygen Concentrator Regulator		101/102 = 1/8 NPT Bottom Connection (barb outlet, see drawings)
<b>Style</b>	_____	201/202 = Manifold Inlet/Outlet (see drawings)
R = Relieving		
N = Non-Relieving		



## Numatics FRL Accessories and Options

### Gauges



GA300 pictured



214-194 pictured

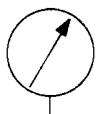

ANSI SYMBOL

### Application

Numatics gauges are widely used on compressors, filter/regulators ('piggy-backs'), water pumps, paint sprayers, and a variety of other applications for measuring the pressure of the air passing through the component.

Numatics Liquid Filled pressure gauges provide maximum service life for your pneumatic gauge applications. Each glycerine filled model is designed to prevent harmful environments or severe vibration from causing premature gauge failure.

### Features

- Utilizes a Power Flex movement with polyester segment, contributing to longer gauge life.
- ABS (Acrylonitrile, Butadiene, Styrene) casing is ideal for rugged applications and harsh environmental conditions
- Full view polycarbonate window for better dial visibility.

### Specifications

All Numatics Gauges

Sizes: 1.5", 2"

Case: Black ABS Composite

Ring: None

Window: Polycarbonate

Dial: Green, Red, and Black on White Background

Pointer: Black Aluminum

Socket: Brass

Liquid Filled Gauges

Liquid Used: Glycerine

Connection: Center Back Mount

### Available Models

#### Numatics Gauges

MODEL	FACE DIAMETER	THREAD SIZE	PRESSURE RANGE (PSIG)	PRESSURE RANGE (BAR)
GB005	2.0"	1/4 NPT	0-5	0-0.5
RB005	2.0"	1/4 BSPT	0-5	0-0.5
GB015	2.0"	1/4 NPT	0-15	0-1.0
RB015	2.0"	1/4 BSPT	0-15	0-1.0
GA030	1.5"	1/8 NPT	0-30	0-2.0
RA030	1.5"	1/8 BSPT	0-30	0-2.0
GA060	1.5"	1/8 NPT	0-60	0-4.0
RA060	1.5"	1/8 BSPT	0-60	0-4.0
GA100	1.5"	1/8 NPT	0-100	0-7.0
RA100	1.5"	1/8 BSPT	0-100	0-7.0
GA160	1.5"	1/8 NPT	0-160	0-11.0
RA160	1.5"	1/8 BSPT	0-160	0-11.0
GA300	1.5"	1/8 NPT	0-300	0-20.0
RA300	1.5"	1/8 BSPT	0-300	0-20.0
GB030	2.0"	1/4 NPT	0-30	0-2.0
RB030	2.0"	1/4 BSPT	0-30	0-2.0
GB060	2.0"	1/4 NPT	0-60	0-4.0
RB060	2.0"	1/4 BSPT	0-60	0-4.0
GB100	2.0"	1/4 NPT	0-100	0-7.0
RB100	2.0"	1/4 BSPT	0-100	0-7.0
GB160	2.0"	1/4 NPT	0-160	0-11.0
RB160	2.0"	1/4 BSPT	0-160	0-11.0
GB300	2.0"	1/4 NPT	0-300	0-20.0
RB300	2.0"	1/4 BSPT	0-300	0-20.0

#### Numatics 14 Series Manifold Regulator Gauges

MODEL	FACE DIAMETER	THREAD SIZE	PRESSURE RANGE (PSIG)	PRESSURE RANGE (BAR)
GB060A	1.5"	1/4 NPT	0-60	0-4.0
RB060A	1.5"	1/4 BSPT	0-60	0-4.0
GB160A	1.5"	1/4 NPT	0-160	0-11.0
RB160A	1.5"	1/4 BSPT	0-160	0-11.0

#### Numatics Liquid-Filled Gauges

MODEL	FACE DIAMETER	THREAD SIZE	PRESSURE RANGE (PSIG)	PRESSURE RANGE (BAR)
214-194	1.5"	1/8	0-160	0-11
214-195	2.0"	1/4	0-160	0-11
214-196	1.5"	1/8	0-60	0-4



### Mounting Brackets

#### Application

Mounting brackets are used to fix a regulator, piggy-back or **FLEXIBLOK®** assembly to a panel as an alternative to the integral mounting holes located in the 22 and 32 Series **FLEXIBLOK®** heads. They are also used as an alternative to a hard piped mounting system for the 12, 50, 70, 71, and 600 Series filter product lines.

#### Panel Mount Nuts

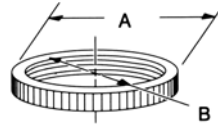

Panel mount nuts thread onto the bonnet of the regulator to secure the unit against the mounting bracket.

MODEL	SERIES	A	B	HOLE DIA.
PN10	71 Series Mini Stainless	1.38 (35)	1-3/4-18 UNS-2B	1.25 (32)
PN12	12 Series FlexiBlok	1.5 (38)	1-3/16- 16	1.25 (32)
PN22	22 Series FlexiBlok	1.5 (38)	1-1/4-16	1.31 (33)
PN32P	32 Series FlexiBlok	2.05 (52)	1-3/4-16	1.77 (45)
PN70S	70 Series Stainless Steel	2.0 (51)	1-3/4-18 UNS-2B	1.75 (44)

### Models and Dimensions

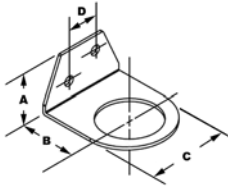

**PK12, PK22 Mounting Bracket for 12 and 22 Series FLEXIBLOK® Regulator and Piggyback**  
includes bracket and panel mount nut (see panel mount nut dimensions below)

Series	Model #	Dimensions			
		A	B	C	D
12,22	PK12 & PK22	1.05 (27)	1.19 (30)	1.75 (44)	.625 (16)

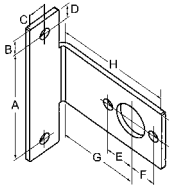

**BRK14AB Mounting Bracket for 14 Series FLEXIBLOK® Regulator and Piggyback**  
includes left and right brackets, 2 left side bolts, and 2 right side nuts (see dimensions below)

Kit #	Dimensions								
	A	B	C	D	E	F	G	H	I
BRK14AB	2.78 (71)	.35 (9)	.4 (10)	.35 (9)	.6 (15)	.6 (15)	1.8 (46)	2.62 (67)	.73 (19)

The right bracket mounts using the bolts that are included with the unit the bracket is being mounted to.

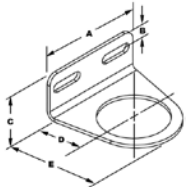

**PK32 Mounting Bracket for 32 Series FLEXIBLOK® Regulator and Piggyback**  
includes bracket and panel mount nut (see panel mount nut dimensions below)

Series	Model #	Dimensions				
		A	B	C	D	E
32	PK32	2.75 (70)	.41 (10)	1.19 (30)	1.5 (38)	2.67 (68)



**BRK22AB Mounting Bracket for 22 Series FLEXIBLOK®**  
includes left bracket, right bracket, 2 right side bolts, 2 right side nuts

Kit #	Dimensions						
	A	B	C	D	E	F	G
BRK22AB	1.57 (39)	.785 (20)	1.45 (37)	2.9 (74)	.4 (10)	3.5 (89)	1 (25)

dimensions shown for BRK22A. BRK22B is a mirror of BRK22A  
Drawing and/or dimensions subject to change

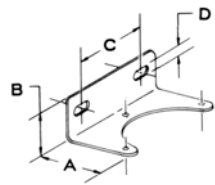

**PK50, PK50A, PK50B Mounting Bracket for 50 Series High Flow Regulator**  
includes one bracket

Port Size	Kit #	Dimensions			
		A	B	C	D
1/4 & 3/8	PK50A	2.25 (57)	1.19 (30)	1.88 (48)	.27 (7)
1/2	PK50B	2.25 (57)	1.06 (27)	1.88 (48)	.27 (7)
3/4 - 1 1/2	PK50	2.94 (75)	1.75 (44)	3.25 (83)	.33 (8)

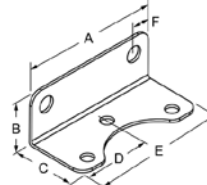

**PK88\* Mounting Bracket for R87 Series Ratio Relay Volume Booster and R88 Series High Flow Precision Regulator**  
includes one bracket

Kit #	Dimensions					
	A	B	C	D	E	F
PK88	3 (76)	1.13 (29)	1.38 (35)	1.5 (38)	3 (76)	.4 (10)

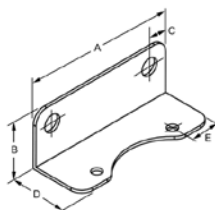

**PK89\* Mounting Bracket for 89 Series Instrument Air Regulator**  
includes one bracket

Kit #	Dimensions				
	A	B	C	D	E
PK89	3 (76)	1.13 (29)	.375 (10)	1.12 (28)	.625 (16)

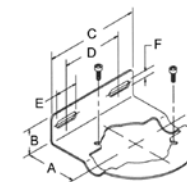

**PK610 607,610 Series High Flow Filters** includes one bracket

Kit #	Dimensions					
	A	B	C	D	E	F
PK610	2.12 (54)	1.19 (30)	3.78 (96)	2.69 (68)	.88 (22)	.27 (7)

\* See individual Precision Pneumatic Control Product pages for additional mounting bracket information (pg 71).

# NUMATICS

*World Class Supplier  
of Pneumatic Components*

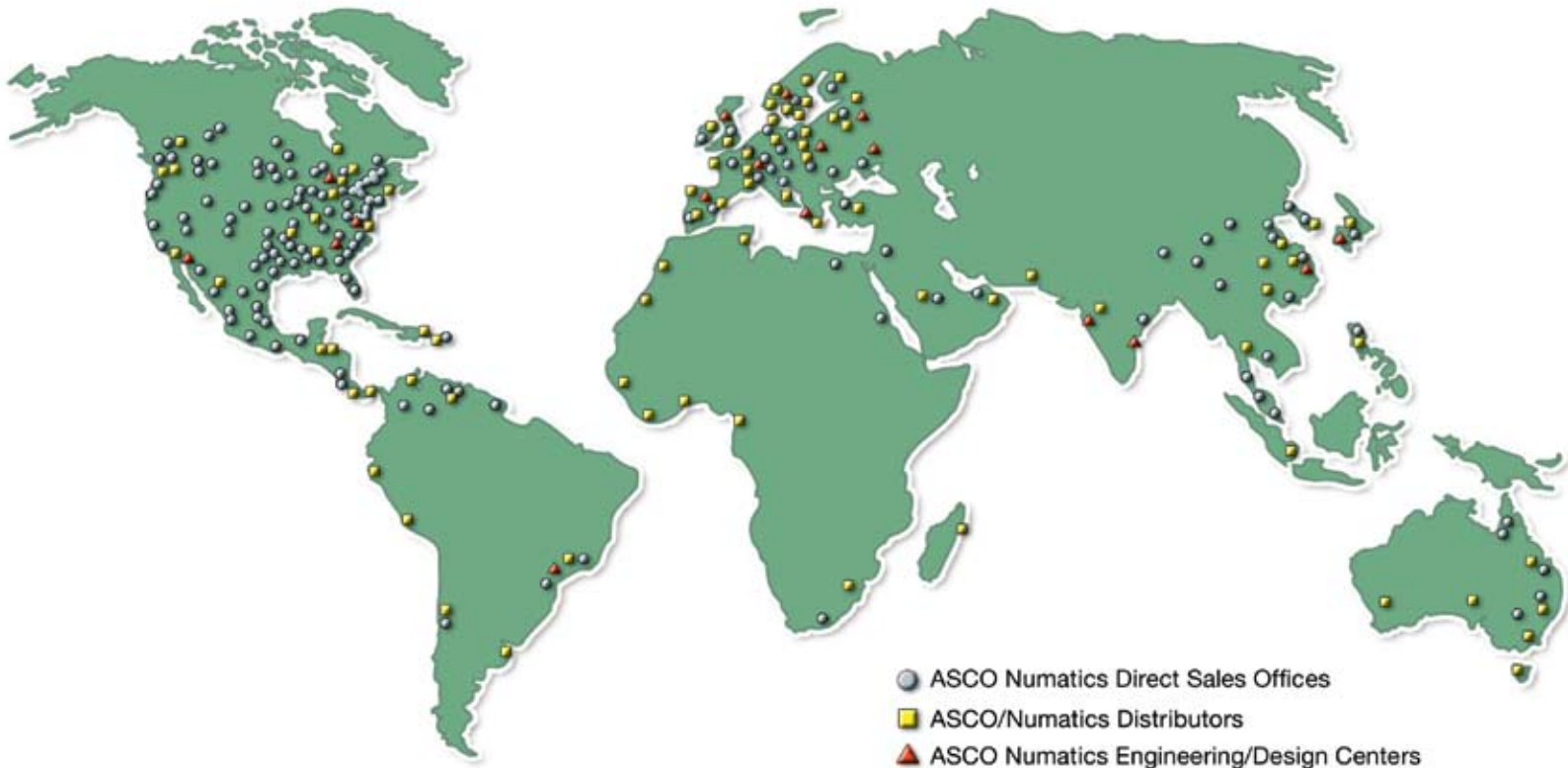

## WORLD HEADQUARTERS

### USA

#### Numatics, Incorporated

46280 Dylan Drive  
Novi, Michigan 48377

P: 1-888-Numatics  
1-888-686-2842

### Canada

#### Numatics, Ltd

P: 519-452-1777

### Mexico

#### Numatics de Mexico S.A. de C.V.

P: 52-222-284-6176

For a comprehensive listing of all Numatics production and distribution facilities worldwide, visit:

**[www.numatics.com](http://www.numatics.com)**