

# EC12

## 6U CompactPCI Celeron Single Board Computer

### Features

- Celeron 1.86 MHz processor with 2MB cache and 1066 MHz integrated memory interface
- Single slot 6U CPCI form factor
- 2 Gbytes DDR3 SDRAM with ECC (soldered components)
- PICMG® compliant
- BIOS backup Flash
- User EEPROM
- Optional onboard SATA HDD or Solid State disk
- One PMC or XMC site
- Front I/O:
  - Two Gigabit Ethernet ports
  - One USB
  - One COM 3
  - Optional via PMC or XMC
- Rear I/O:
  - Two Gigabit Ethernet ports – PICMG 2.16
  - VGA 1 & 2
  - DVI 1 and 2
  - Four SATA (3 Gb/s) interfaces
  - COM 1 and 2 ports
  - Four USB ports
  - GPIOs
  - PMC/XMC I/O signals

- 6/6 RoHS and WEEE directives compliant; UL, FCC, and CE Mark registrations
- IPMI 2.0 PICMG® 2.9
- Watchdog, temperature sensors
- OS support: Windows®, standard distribution Linux® and VxWorks.
- Customization on request

The EC12 is a single slot 6U CompactPCI® SBC with Celeron 1.86 MHz processor with 2MB cache and a 1066 MHz integrated memory interface. The assembly is fully compliant to the PICMG® specifications.

Two banks of DDR3 SDRAM components provide 2 GBytes of main memory with ECC.

The BIOS Flash is backed with a second Flash device in order to recover the BIOS in the event the primary BIOS is corrupted.

One high performance PMC or XMC slot gives the user the freedom to expand the functionality through off-the-shelf mezzanine modules.

Applications with the need for higher shock & vibration immunity benefit due to soldered memory and optional use of a Solid-State-Disk.

The EC12 is equipped with IPMI 2.0 functionality. Supported operating systems include Windows®, Linux® and VxWorks.

The upper limit of the temperature range depends on the optional population with a PMC, XMC mezzanine or a SATA hard drive.

The EC12 is designed for use in a broad range of applications such as telecom / communications, industrial control and automation, test, and measurement systems. This, combined with a customer specific assembly service, provides optimized price and performance levels.

Please contact GE Intelligent Platforms for a current list of OS versions supported on the EC12.



# EC12 6U CompactPCI Celeron Single Board Computer

## EC12 Safety and Reliability Benefits

### Soldered processor and memory

Increased immunity against shock and vibration

### BIOS Backup Flash

Fast recovery when BIOS upgrade got corrupted

Controlled via IPMI controller

Update via factory only

## Specifications

### Processor

- Celeron P4505, 1.86 GHz
- Cache: 2 MB, full speed, 2x (64K + 512K)
- 1066MHz integrated memory interface
- Fanless cooling with heat sink
- Two PCI Express x8 ports
- FDI and DMI interface to I/O Controller hub

### CompactPCI

- PICMG 2.0 R3.0 compliant CPCI local bus standard
- 64-bit PCI for up to 8 slots (33 MHz) or 5 slots (66 MHz)
- Supports both system Host and Peripheral Mode in a single assembly
- 2 mm pin and socket connectors (IEC-1076-4-101)

### I/O Controller Hub

- FDI and DMI interface to processor
- Supplies I/O interfaces/functions to front & rear
- 8 PCI Express ports
- Choice of four display channels

### Main Memory Array

- Dual channel DDR3 SDRAM array: 2 banks soldered memory components
- 144-bit wide with error correction (ECC)
- 2 GBytes

### Front Dual Gigabit Ethernet

- Twin Intel® 82574L PCI Express Ethernet controllers
- 10/100/1000BaseT auto-negotiation

### Rear Dual Gigabit Ethernet

- Twin Intel® 82574L PCI Express Ethernet controllers
- 10/100/1000BaseT auto-negotiation
- Compliant to PICMG® 2.16

### Onboard Hard Disk or SSD Drive

- Optional internal 2.5" SATA hard disk or 2.5" SATA Solid State Drive (SSD)
- Usage of SSD is recommended for high shock and vibration immunity

### PMC/XMC Extension Slot

- PMC (64-bit PCI, up to 133 in PCI-X mode) or XMC with PCI Express x8 (Gen2, 2.5 Gbit/s)
- PCI signaling is 3.3V, 5V tolerance

### SATA

- Four SATA (3 Gb/s) ports to rear I/O

### Serial I/O

- Three asynchronous 16550 compatible full duplex serial channels
- High-speed transfer up to 115.2 kbaud with 16 byte FIFOs
- Two user selectable RS-232/422/485 interfaces at rear
- COM3 RS-232 available at front via HarLink® connector

### Video/Graphics Interface

- Intel integrated 3D graphics controller
- Two VGA port plus two DVI-D ports at rear I/O
- Any two ports can be used for dual display operation
- Fully compliant support for OpenGL™ for Linux

### General Purpose I/O

- 13 GPIO (input or output) pins
- Software configurable
- Hardware Write Protection of programmable devices

### USB Ports

- One USB 2.0 connector on the front
- Four USB 2.0 channels on rear

### Keyboard and Mouse

- Via USB
- Legacy PS/2 controller emulation

### Real-time Clock

- RTC 146818 compatible
- Li-battery

### EEPROM

- 512 kbit serial EEPROMs for non-volatile user data

### Timer

- Integrated in Hub controller
- Legacy PC-AT timer
- HPET High Precision Event Timer

### Watchdog

- Integrated in Super I/O

### Temperature Sensors

- CPU die and chipset die temperature software readable in the range of -15°C to +105°C

### LED

- Front panel ACPI system Status indicator LED (red/amber/green)
- CompactPCI Hot swap (blue) on front panel

### Hot-Swap - compliant to PICMG 2.1

- Peripheral mode: full CompactPCI Hot Swap
- System Host mode: CompactPCI ENUM# event support through ACPI or legacy driver

### BIOS Features

- New AMI Aptio UEFI, in-system programmable Flash ROM
- CPU, memory and SATA auto-detection/selection
- Integrated Ethernet PXE driver
- USB mass storage support and booting capability (floppy, HDD, CDROM, and onboard Flash ROM array)
- Password protection
- Headless operation

### IPMI 2.0

- Baseboard Management Controller supporting the Intelligent Platform Management Interface (IPMI) architecture in compliance with PICMG® 2.9
- Peripheral mode and BMC mode are supported
- IPMI is an optional function

### Software

- Windows XP
- Windows 7
- Linux
- VxWorks 6.8

Front and Rear I/O (Transition Module CTM20)		
Function	Front	Rear
VGA 1		•
VGA 2		•
DVI 1 & 2		•
COM 1 & 2		•
COM 3	•	
USB 0 - 3		•
USB 4	•	
Ethernet 1,2	•	
Ethernet 3,4		•
SATA 2-5		•
GPIO		•
LEDs	•	•
PMC / XMC I/O	•	•
Power Button	•	•

# EC12 6U CompactPCI Celeron Single Board Computer

## Specifications

### Power Requirements

- +5 V, +3.3V, +12V
- -12V if required by mounted PMC/XMC module

### Power Allowances – PMC/XMC Slot

- +5 V, +3.3 V: Total power max. 7.5 W
- ±12 V: 100mA

### Power Consumption - typical operating current

- See manual.

### Environmental

- Operating Temperature\*: 0° C to +60° C @ 1.5m/s airflow
- Storage Temperature: -40° C to +85° C
- Humidity: 5 - 95% @ 40° C
- Altitude:
  - Operating: 15,000 ft. (4,5 km)
  - Storage 40,000 ft. (12 km)
- Shock & Vibration:
  - Designed to meet VITA47 class EAC1 and EAC3

### Mechanical – PICMG 2.0

- 6U, 1 slot wide, 233 mm x 160 mm x 20 mm with hard disk

### MTBF

- Prediction calculations are available in accordance with MIL-HDBK-217. Please contact GE Intelligent Platforms.

### Safety

- Designed to meet standard UL1950, CE class A, FCC-A

\*Note: Consult the User's Manual or GE Intelligent Platforms for additional detailed information on the operating temperature behavior of the module. The EC12 operating temperature range is influenced by processor type and speed, operating altitude, and the type of cooling used in the host system.

All values under typical conditions without PMC/XMC module.

## Block Diagram

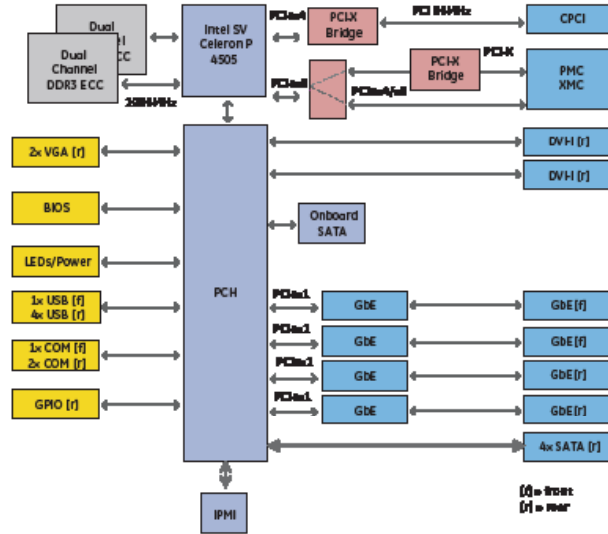

## Ordering Information

### EC12EUD200MA

6U CPCI SBC with Intel Celeron M 440 (1.86 GHz), 2 GB memory with ECC, 1x COM (front), 1x USB (front), 2x COM (rear), 4x USB (rear), 2x VGA & 2x DVI on rear, 2x GbE (rear), 2x GbE (front), 1x PMC/XMC slot, 250 GB SATA HDD, 0 to 55 °C

### YLB-CR12-01

Front I/O COM port cable appr. 200 mm. Harlink connector to serial connector

### DMS59A

DMS-59 compliant Y-cable with two DVI connections for the RTM CTM20

### CTM20A00A

6U I/O RTM with USB 2/3, onboard SATA HDD connector

### CTM20A0MA

6U I/O RTM with USB 2/3, onboard SATA HDD connector and 250 GB HDD

### CTM20A10A

6U I/O RTM with USB 2/3, COM1, VGA, eSATA3, onboard SATA HDD connector

### CTM20A20A

6U I/O RTM with USB 2/3, COM1, VGA, eSATA2/3, onboard SATA HDD connector

### EC12-BSP-VXW

VxWorks 6.8 Board Support Package

### EC12-SDK-LIN

System Development Kit for Linux (Fedora 14, RHEL 5.46 & 6.0, Suse 11.4)

### EC12-SDK-WIN

System Development Kit for Windows XP and Windows 7

For additional configurations, please contact GE Intelligent Platforms.

## About GE Intelligent Platforms

GE Intelligent Platforms, a General Electric Company (NYSE: GE), is an experienced high-performance technology company and a global provider of hardware, software, services, and expertise in automation and embedded computing. We offer a unique foundation of agile, advanced and ultra-reliable technology that provides customers a sustainable advantage in the industries they serve, including energy, water, consumer packaged goods, government and defense, and telecommunications. GE Intelligent Platforms is a worldwide company headquartered in Charlottesville, VA and is part of GE Home and Business Solutions. For more information, visit [www.ge-ip.com](http://www.ge-ip.com).

## GE Intelligent Platforms Contact Information

Americas: 1 800 433 2682 or 1 434 978 5100

Global regional phone numbers are listed by location on our web site at [www.ge-ip.com/contact](http://www.ge-ip.com/contact)

[www.ge-ip.com](http://www.ge-ip.com)

