

MOLDED CASE CIRCUIT BREAKERS

INDIVIDUAL
CATALOG
from D&C CATALOG 19th Edition
Revised

06

S series



Handle-operated type



E series



**Distribution breakers
F series**



H series



Solid-state trip type



**4-pole
S and E series**



Motor operated breakers



**LOW
VOLTAGE
EQUIPMENT
Up to 600 Volts**

D & C CATALOG DIGEST INDEX

Individual
catalog No.

LOW VOLTAGE PRODUCTS Up to 600 Volts

01 Magnetic Contactors and Starters
Thermal Overload Relays, Solid-state Contactors

02 DUO series
Manual Motor Starters and Contactors
Combination Starters

03 Industrial Relays, Industrial Control Relays
Annunciator Relay Unit, Time Delay Relays
Electronic Counters

04 Pushbuttons, Selector Switches, Pilot Lights
Rotary Switches, Cam Type Selector Switches
Panel Switches, Terminal Blocks, Testing Terminals

05 AS-Interface, Limit Switches
Proximity Switches
Photoelectric Switches

06 Molded Case Circuit Breakers

07 Earth Leakage Circuit Breakers
Earth Leakage Protective Relays

08 Circuit Protectors
Low Voltage Current-Limiting Fuses
Air Circuit Breakers

09 Measuring Instruments, Arresters, Transducers
Power Factor Controllers
Power Monitoring Equipment (F-MPC)

10 AC Power Regulators
Noise Suppression Filters
Control Power Transformers

HIGH VOLTAGE PRODUCTS Up to 36kV

11 Disconnecting Switches, Power Fuses
Air Load Break Switches
Instrument Transformers — VT, CT

12 Vacuum Circuit Breakers, Vacuum Magnetic Contactors
Protective Relays

06

Molded Case Circuit Breakers



	Page
Molded Case Circuit Breakers	
General information	06/1
Design features	06/3
Breaking capacities	06/7
Quick reference guide	
Line protection	
S series	06/10
E series	06/18
L, H series	06/22
Motor protection	
S series	06/25
E series	06/27
L, H series	06/28
UL Listed	06/29
Mounting modification	06/38
Terminal connection	06/39
Wire size and terminal	06/40
Type number nomenclature	06/42
Type number	
Line protection	
S series	06/45
E series	06/46
L, H series	06/48
Motor protection	
S series	06/49
E series	06/50
L, H series	06/50
UL Listed	06/51
Dimensions	06/52
Characteristic curves	06/79
Accessories	06/88
Internal accessories	06/90
Motor-operated breakers	06/106
Mechanical interlocking device	06/110
Operating handles	06/113
Steel enclosures	06/126
Terminal covers	06/128
Insulation barriers	06/129
Mounting modification kits	06/130
Padlocking device	06/131
Distribution breakers F series	06/132
Solid-state trip types	06/133
CCC approved	06/140

MINIMUM ORDERS

Orders amounting to **less than ¥10,000** net per order will be charged as ¥10,000 net per order plus freight and other charges.

WEIGHTS AND DIMENSIONS

Weights and dimensions appearing in this catalog are the best information available at the time of going to press.

FUJI ELECTRIC FA has a policy of continuous product improvement, and design changes may make this information out of date.

Please confirm such details before planning actual construction.

INFORMATION IN THIS CATALOG IS SUBJECT TO CHANGE WITHOUT NOTICE.

■ Description

The highest priority for the molded case circuit breakers (MCCBs) and earth leakage circuit breakers (ELCBs) employed in power distribution control systems is to provide sure, safe protection for connected equipment against short-circuits or earth leakage. Fuji Electric FA has led the industry with the α -TWIN Breakers (30 to 800AF), same-size MCCBs and ELCBs. All of these breakers meet exacting demands for quality and performance.

Now, the lineup has been further enhanced with six major concepts — international standardization, utility, technical innovation, compactness, safety and ecology — in the α -TWIN series.

• Outstanding features

α -TWIN Breakers employ a new current-limiting mechanism based on the arc-driving technique for high-speed contact opening and very short arcing time. This, and a dual-latching mechanism, enable 30AF and 225AF MCCBs to interrupt current faster at higher capacities. A special resin with excellent thermal and mechanical

properties produces a more compact molded case for higher breaking capacity.

• Standardized modular construction

Standardized dimensions ease panel design and manufacture. Models 30AF to 225AF are 60mm deep and require a panel cutout height of 52mm.

Models 400AF to 800AF are 103mm deep and require a panel cutout height of 92mm.

With standardized modular construction, α -TWIN Breakers cut panel manufacturing costs.

• A wider range of customer-mountable accessories

The range of cassette-type internal accessories has been greatly expanded for 30AF to 800AF MCCBs.

This speeds up and simplifies customer response to specification changes.

All accessories shown here can be mounted by the customer except for motor operating mechanism and plate type padlocking device.



• Conforming to international standards

The α -TWIN series conforms to IEC and EN standards, and features UL, cUL and CCC.

• Compliance with EN Standards

FUJI's MCCBs conform to the European Standards for circuit breakers (EN60947-2 = IEC60947-2). (E and S series, 30AF to 800AF only)

■ Types of MCCBs

• Line protection

For general-purpose circuit protection

This type of MCCB may be employed in both main and branch circuits. They are installed in motor control centers and distribution boards to provide protection from both overload and short-circuit currents.

The overcurrent trip mechanism of the general-purpose MCCB consists of thermal and magnetic elements.

Thermal trip action and magnetic trip action provided overcurrent protection and short-circuit protection, respectively.

For distribution boards

These MCCBs are used exclusively in branch circuits of distribution boards for lighting installations. These breaker are compact and suitable for mounting in groups. These circuit breakers are available in 50 and 100AF (Ampere Frame) types, and their breaking capacities are within the 2.5kA to 5.5kA range.

• Motor-protection

The line current ratings of MCCBs for motor protection are equal to the motor's full-load current to provided motor overload and line overcurrent protection. These MCCBs obviate the need for magnetic motor starters. Since these MCCBs control motor start-stop operation, they must be used with loads which do not require frequent switching. These MCCBs handle starting rush currents of up to 600% and enable starting times of up to two seconds.

These MCCBs are for general-purpose, 3-phase squirrel-cage induction motors with direct-on-line starting.

• Solid-state trip

These solid-state trip type MCCBs incorporate a trip device with a built-in microprocessor. Rated current levels can be selected in five to six steps, and a wide variety of tripping parameters, including long-time delay, short-time delay, and instantaneous

tripping, can be set with high precision. These MCCBs are ideal for providing selective trip protection coordination with various protective devices, such as fuses and other MCCB units. This type of MCCB also increases the reliability of the power supply.

Molded Case Circuit Breakers

General information

Models and applications

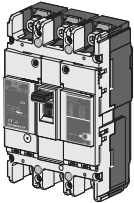
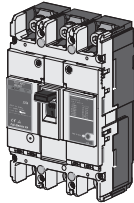
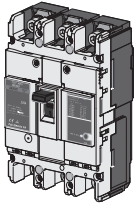
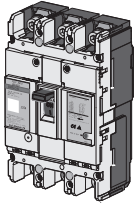
CE marking		UL approved	
Line protection		Motor protection	
S series	E series	S, E series	S-UL, E-UL series
			
Used for equipment with a capacity range of 15 to 20kVA. Satisfies EN (IEC) standards and bears CE markings.	Ideal for circuits with comparatively low short-circuit current. Satisfies EN (IEC) standards and bears CE markings. Enables the design of compact, economical control panels. The depth is 60mm for types with a capacity range of 30 to 225A.	This breaker protects motors from overload and cables from excessive current.	This breaker is UL and CSA approved. Satisfies EN (IEC) standards and bears CE markings.

Varieties of MCCBs

IEC and CE marking conformed

Frame size		30AF	50AF	60AF	100AF	225AF	400AF	600AF	800AF
Line protection	S series	SA30C□-CE	SA50C□-CE SA50RC□-CE	SA60C□-CE SA60RC□-CE	SA100C□-CE SA100RC□-CE	SA225C□-CE SA225RC□-CE	SA400C□-CE SA400RC□-CE	SA600RC□-CE	SA800RC□-CE
	E series	EA30AC□-CE	EA50AC□-CE EA50C□-CE	EA60C□-CE	EA100AC□-CE EA100C□-CE	EA225C□-CE	EA400C□-CE	EA600C□-CE	EA800C□-CE
Motor protection	S series	SA30CM□-CE	SA50CM□-CE SA50RCM□-CE	SA60CM□-CE	SA100CM□-CE SA100RCM□-CE	SA225CM□-CE SA225RCM□-CE	-	-	-
	E series	EA30ACM□-CE	EA50CM□-CE	EA60CM□-CE	EA100CM□-CE	EA225CM□-CE			

Note: Type number with "-CE" indicates the IEC and CE marking conformed model, but type number without "-CE" indicates also the same.

UL489 Listed

Frame size		30AF	50AF	60AF	100AF	225AF	400AF	600AF	800AF
UL489 Listed	SA-UL	-	SA50RCUL	-	SA100CUL SA100RCUL	SA225CUL SA225RCUL	SA400CUL SA400RCUL	SA600RCUL	SA800RCUL
	EA-UL	-	-	-	EA100CUL	-	-	-	-

JIS C8370

Frame size	30AF	50AF	60AF	100AF	225AF	400AF	600AF	800AF
S series	-	-	-	-	-	-	-	-
L series H series	-	LA50B H50C	-	H100C H100R	H225C H225R	H400C H400R	H600C H600R	H800C H800R
4-pole	-	SA54B	-	EA104B SA104R	SA204R	SA404HA	SA604H	SA804H
F series	-	F51B F52B F53B	-	F102B F103B	-	-	-	-

Note: Solid-state trip type is also available. SA1000E, 1200E, 1600E

■ Design features

Direct-Drive switching mechanism

A vertical link mechanism is used for the switching mechanism to reduce the torque of the moving contact arm, serve as a countermeasure against increased contact opening distance, and improve contact opening speed.

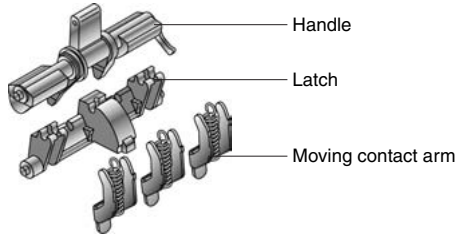

Contact opening distance/Moving contact arm torque

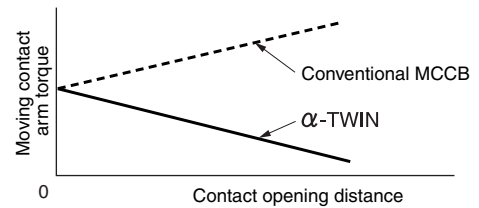

High-performance arc quenching chamber

The combination of the simple Flat Turn contact arm, blowout magnet, and arc-quenching chamber provided a unique current-limiting effect.

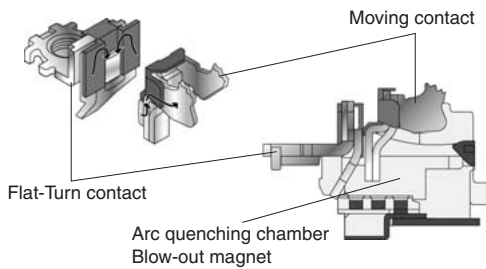

Structure of the arc-quenching chamber

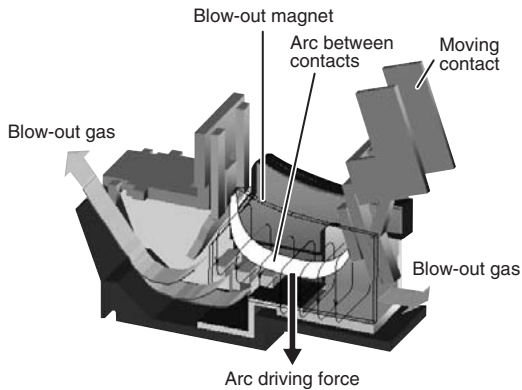

Comparison of arc voltages resulting from short-circuit current

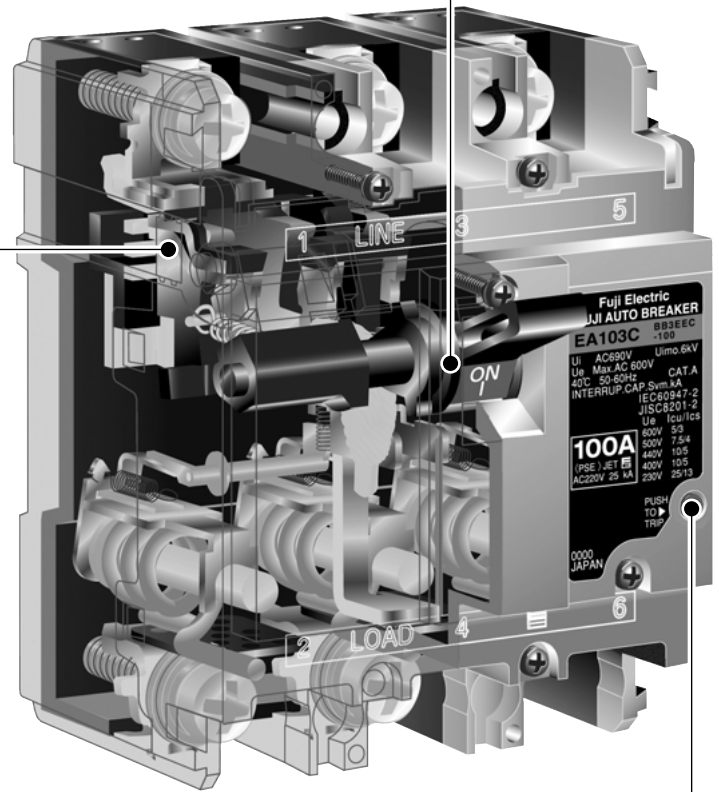
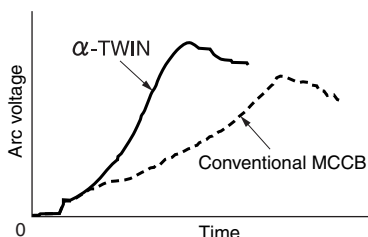

Trip button

The MCCB can be mechanically tripped externally.

Molded Case Circuit Breakers

Design features

Model configuration

Model configuration

Standardization of the main dimensions of the MCCB's has a large effect on panel design, manufacturing and appearance.

Modular construction

Standardized modular construction
30AF to 800AF α -TWIN Breakers standardized basic dimensions — panel design and cutouts are simplified for manufacturing cost savings. The number of mounting space sizes for the 30AF to 800AF S and E series models has been reduced to 5. New α -TWIN Breakers are available in two standard depths: 60 and 103mm, choose it from two front panel cutout height of 52mm or 92mm. The operating handle is at the center of the breaker and its panel cutout for eased panel design, manufacture, and mounting are easy. Terminal height above the panel of models 30AF to 225AF is standardized at 24mm to ease wiring.

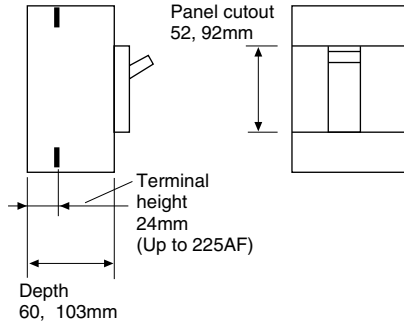

Side-by-side installation

A pole width of 25mm was selected for distribution panel breakers and economy type general-purpose breakers with frame size of 100A and smaller. Therefore, extremely rational procedures can be devised for panel machining and wiring.



Thin terminal block

The terminal block for internal accessory is now thinner (1/2 the size of conventional type). Thus, the space between breakers has been reduced to less than 1/3 that required by conventional type. (EA100AF or smaller)

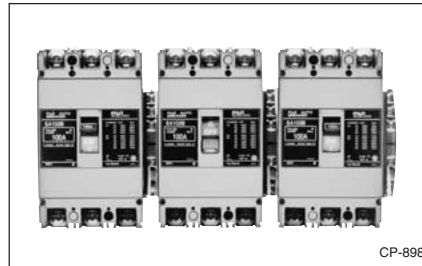

Compact and lightweight

These breakers are more compact and lightweight than those of the old series. Photos are a comparison of new EA103C breakers and old EA103B.

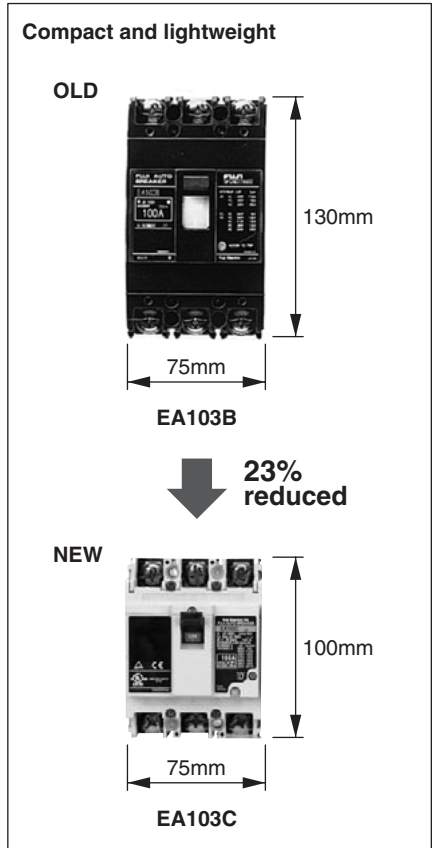

The standardization of depths reduces the number of frame sizes from 6 to 5.

Conventional series dimensions (30AF to 800AF)

						(mm)	
						60	96
EA30 EA50A EA100F	SA30B EA50B SA50B EA60B SA50R EA100B SA60B EA600B SA60R	SA100BA SA100RA	SA225BA EA225B SA225RA	SA400B EA400B SA400R	SA600R EA600B SA800R EA800B	60	130
						60	155
						60	165
						103	257
						103	275
α-TWIN series dimensions							
						60	100
SA30C EA30AC SA50C EA50AC SA50RC EA50C SA60C EA60C SA60RC EA100AC EA100C	SA103C EA103RC	SA225C EA225C SA225RC	SA400C EA400C SA400RC	SA600RC EA600C SA800RC EA800C		60	155
						60	165
						103	257
						103	275

Note : The figures show the dimensions of three-pole models

■ Front mounting front connection

4 main types of terminals are as shown in the photos. Terminal screws are self-lifting, pan-head screw, hexagonal socket head screw and flat terminal which are tighten because bolts are used.

Terminals vary according to the current capacity of each type of housing. All breaker terminals should be connected to copper crimp connectors or copper bus bars. Never connect to aluminium conductors, since overheating can be expected.

Self-lifting terminal



Screw terminal (Pan-head bolt)

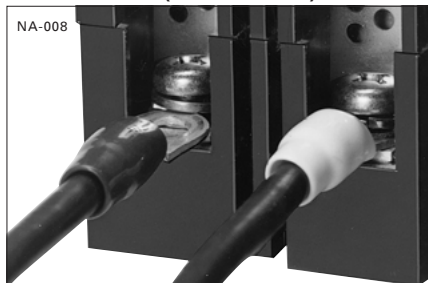

Screw terminal (Hexagonal socket head bolt)



Flat terminal

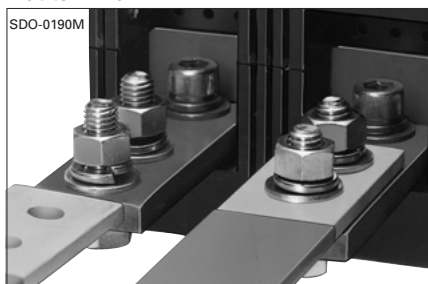

Terminal covers

Since the live conductors are exposed at the MCCB terminals there is the danger of accidental contact.

A terminal cover can be provided where necessary.

For further information refer to page 06 /128.

Short type

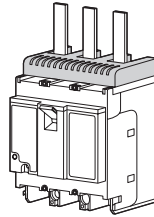

Long type

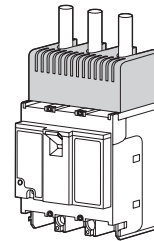

Modular design — Up to 225AF E and S series (α-TWIN series)

Since molded cases generally have common dimensions and outlines they can easily be installed on distribution boards in uniform neat groupings, with switches lined up in a row. E and S series up to 225AF are built on the modular system. For instance the depth is 60mm while the panel cutout height of 52mm. The standardization of the MCCBs and panel board allows the speed up of assembling and wiring of the panel and permits panel surface processing to be carried out in a shorter period of time.

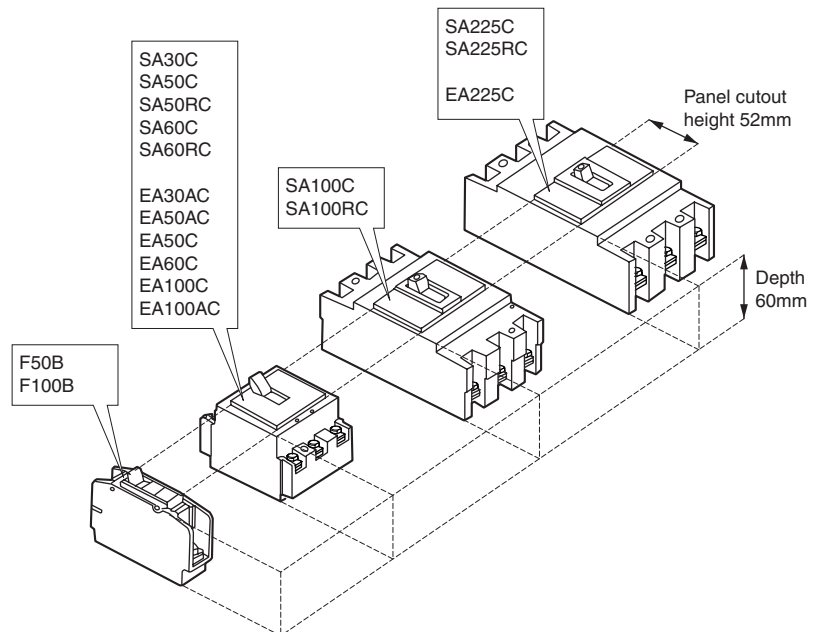

Molded Case Circuit Breakers

Design features

Accessories

■ Internal and external accessories A wider range of customer-mountable accessories

The range of cassette-type internal accessories has been greatly expanded for α -TWIN MCCBs. This speeds up and simplifies customer response to specification changes. All accessories shown here can be mounted by the customer except for motor operating mechanism and plate type padlocking device.

Wide variety of internal accessory combinations

Up to two auxiliary switches, two alarm switches, and one shunt trip device or undervoltage trip device quickly snap on or in.

Quick and easy mounting

No need to open breaker cover to mount accessories. Internal accessories easily snap into a pocket at the left of the breaker window frame.

No adjustments

Accessory mounting is quick and easy — accessories adjust automatically at the correct position when mounted.

Two ways to connect — lead wires or terminal blocks

• Lead wire types

Leads are marked with to indicate the correct terminal number of the accessory — incorrect wiring is minimized. To make wiring easy and prevent to incorrect connection, the lead wires are provided with color coated tube and marking on it.

• Terminal block types

Terminal blocks are mounted on the side of the breaker case. Blocks are only 12.5 or 19mm thick, minimizing panel mounting space. Installed lead wires are parallel to the side of the case.

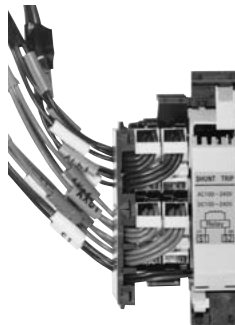

AF93-82

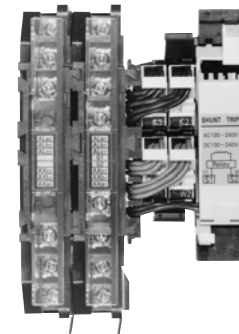

AF93-81

Alarm switch 	Auxiliary switch 	Shunt trip device 	Undervoltage trip device 	Terminal block
Terminal covers Long type Short type 	Insulation barriers Interphase barrier Earth barrier 	Motor operating mechanism 	Mechanical interlocking device 	
Steel enclosure 	Handle padlocking device Handle locking cover 	Operating handles N type V type 	Modification kits For front mounting, rear connection For plug-in mounting For flush mounting, rear connection 	

■ IEC60947-2, JIS C8201-2 / IEC and CE marking conformed

Series	Breaker ampere frame	Basic type	Pole	Rated current (A)	Insulation voltage Ui (V)	Breaking capacity (kA)[Icu/Ics]										
						IEC60947-2										JIS C8201-2 DC
						AC	230V	380V	400V	415V	440V	500V	600V	250V		
S	30	SA32C□-CE	2	3, 5, 10, 15, 20, 30	690	5/3	2.5/2	2.5/2	2.5/2	2.5/2	2.5/2	1.5/1	—	2.5/2		
	30	SA33C□-CE	3	3, 5, 10, 15, 20, 30	690	5/3	2.5/2	2.5/2	2.5/2	2.5/2	2.5/2	1.5/1	—	2.5/2		
	50	SA52C□-CE	2	5, 10, 15, 20, 30, 40, 50	690	10/5	7.5/4	7.5/4	7.5/4	7.5/4	7.5/4	5/3	2.5/2	5/3		
	50	SA53C□-CE	3	5, 10, 15, 20, 30, 40, 50	690	10/5	7.5/4	7.5/4	7.5/4	7.5/4	7.5/4	5/3	2.5/2	5/3		
	50	SA52RC□-CE	2	10, 15, 20, 30, 40, 50	690	25/13	10/5	10/5	10/5	10/5	10/5	7.5/4	5/3	5/3		
	50	SA53RC□-CE	3	10, 15, 20, 30, 40, 50	690	25/13	10/5	10/5	10/5	10/5	10/5	7.5/4	5/3	5/3		
	60	SA62C□-CE	2	60	690	10/5	7.5/4	7.5/4	7.5/4	7.5/4	7.5/4	5/3	2.5/2	5/3		
	60	SA63C□-CE	3	60	690	10/5	7.5/4	7.5/4	7.5/4	7.5/4	7.5/4	5/3	2.5/2	5/3		
	60	SA62RC□-CE	2	60	690	25/13	10/5	10/5	10/5	10/5	10/5	7.5/4	5/3	5/3		
	60	SA63RC□-CE	3	60	690	25/13	10/5	10/5	10/5	10/5	10/5	7.5/4	5/3	5/3		
	100	SA102C□-CE	2	15, 20, 30, 40, 50, 60, 75, 100	690	50/25	30/8	30/8	30/8	30/8	25/7	15/4	—	15/8		
	100	SA103C□-CE	3	15, 20, 30, 40, 50, 60, 75, 100	690	50/25	30/8	30/8	30/8	30/8	25/7	15/4	—	15/8		
	100	SA102RC□-CE	2	15, 20, 30, 40, 50, 60, 75, 100	690	100/50	50/13	50/13	50/13	50/13	50/13	30/8	—	40/20		
	100	SA103RC□-CE	3	15, 20, 30, 40, 50, 60, 75, 100	690	100/50	50/13	50/13	50/13	50/13	50/13	30/8	—	40/20		
	225	SA202C□-CE	2	125, 150, 175, 200, 225	690	50/25	30/8	30/8	30/8	30/8	25/7	15/4	—	15/8		
	225	SA203C□-CE	3	125, 150, 175, 200, 225	690	50/25	30/8	30/8	30/8	30/8	25/7	15/4	—	15/8		
	225	SA202RC□-CE	2	125, 150, 175, 200, 225	690	100/50	50/13	50/13	50/13	50/13	50/13	30/8	—	40/20		
	225	SA203RC□-CE	3	125, 150, 175, 200, 225	690	100/50	50/13	50/13	50/13	50/13	50/13	30/8	—	40/20		
	400	SA402C□-CE	2	250, 300, 350, 400	690	50/25	35/18	35/18	35/18	35/18	35/18	22/11	—	20/10		
	400	SA403C□-CE	3	250, 300, 350, 400	690	50/25	35/18	35/18	35/18	35/18	35/18	22/11	—	20/10		
	400	SA402RC□-CE	2	250, 300, 350, 400	690	85/43	50/25	50/25	50/25	50/25	50/25	35/18	30/15	40/20		
	400	SA403RC□-CE	3	250, 300, 350, 400	690	85/43	50/25	50/25	50/25	50/25	50/25	35/18	30/15	40/20		
	600	SA603RC□-CE	3	500, 600	690	85/43	50/25	50/25	50/25	50/25	50/25	35/18	30/15	40/20		
	800	SA803RC□-CE	3	700, 800	690	85/43	50/25	50/25	50/25	50/25	50/25	35/18	30/15	40/20		
	E	30	EA32AC□-CE	2	3, 5, 10, 15, 20, 30	500	2.5/2	1.5/1	1.5/1	1.5/1	1.5/1	—	—	—		
		30	EA33AC□-CE	3	3, 5, 10, 15, 20, 30	500	2.5/2	1.5/1	1.5/1	1.5/1	1.5/1	—	—	—		
		50	EA52AC□-CE	2	5, 10, 15, 20, 30, 40, 50	500	2.5/2	1.5/1	1.5/1	1.5/1	1.5/1	—	—	—		
		50	EA53AC□-CE	3	5, 10, 15, 20, 30, 40, 50	500	2.5/2	1.5/1	1.5/1	1.5/1	1.5/1	—	—	—		
50		EA52C□-CE	2	5, 10, 15, 20, 30, 40, 50	690	5/3	2.5/2	2.5/2	2.5/2	2.5/2	2.5/2	1.5/1	—	2.5/2		
50		EA53C□-CE	3	5, 10, 15, 20, 30, 40, 50	690	5/3	2.5/2	2.5/2	2.5/2	2.5/2	2.5/2	1.5/1	—	2.5/2		
60		EA62C□-CE	2	60	690	5/3	5/3	2.5/2	2.5/2	2.5/2	2.5/2	1.5/1	—	2.5/2		
60		EA63C□-CE	3	60	690	5/3	5/3	2.5/2	2.5/2	2.5/2	2.5/2	1.5/1	—	2.5/2		
100		EA103AC□-CE	3	60, 75, 100	500	5/3	1.5/1	1.5/1	—	—	—	—	—	—		
100		EA102C□-CE	2	50, 60, 75, 100	690	25/13	10/5	10/5	10/5	10/5	10/5	7.5/4	5/3	5/3		
100		EA103C□-CE	3	50, 60, 75, 100	690	25/13	10/5	10/5	10/5	10/5	10/5	7.5/4	5/3	5/3		
225		EA202C□-CE	2	125, 150, 175, 200, 225	690	35/18	18/5	18/5	18/5	18/5	15/4	10/3	—	10/5		
225		EA203C□-CE	3	125, 150, 175, 200, 225	690	35/18	18/5	18/5	18/5	18/5	15/4	10/3	—	10/5		
400		EA402C□-CE	2	250, 300, 350, 400	690	35/18	25/13	25/13	25/13	25/13	25/13	18/9	—	20/10		
400		EA403C□-CE	3	250, 300, 350, 400	690	35/18	25/13	25/13	25/13	25/13	25/13	18/9	—	20/10		
600		EA603C□-CE	3	500, 600	690	50/25	35/18	35/18	35/18	35/18	35/18	22/11	—	20/10		
800		EA803C□-CE	3	700, 800	690	50/25	35/18	35/18	35/18	35/18	35/18	22/11	—	20/10		

Note: For details of breaking capacity, see page 06/10 "Quick reference guide".

Series	Breaker ampere frame	Basic type	Pole	Rated current (A)	Insulation voltage Ui (V)	Breaking capacity (kA)[Icu/Ics]					DC 250V
						IEC60947-2					
						AC	230V	400V	440V	500V	600V
S	1000	SA1003E	3	500-600-700-800-900-1000	690	100/75	65/49	65/49	45/34	25/19	—
		SA1004E	4	500-600-700-800-900-1000	690	100/75	65/49	65/49	45/34	25/19	—
	1200	SA1203E	3	600-700-800-1000-1200	690	100/75	65/49	65/49	45/34	25/19	—
		SA1204E	4	600-700-800-1000-1200	690	100/75	65/49	65/49	45/34	25/19	—
	1600	SA1603E	3	800-900-1000-1200-1400-1600	690	125/94	85/64	85/64	65/49	45/34	—
		SA1604E	4	800-900-1000-1200-1400-1600	690	125/94	85/64	85/64	65/49	45/34	—

Molded Case Circuit Breakers

Breaking capacities

■ JIS C8370

Series	Breaker ampere frame	Basic type	Pole	Rated current (A)	Insulation voltage Ui (V)	Breaking capacity (kA)								
						AC								DC 250V
						220V	240V	380V	415V	500V	600V	660V		
H	100	H103R	3	40, 50, 60, 75, 100	660	125	125	100	85	42	35	–	40	
	225	H203R	3	125, 150, 175, 200, 225	660	125	125	100	85	42	35	–	40	

Series	Breaker ampere frame	Basic type	Pole	Rated current (A)	Insulation voltage Ui (V)	Breaking capacity (kA)								
						AC								DC 250V
						220V	240V	380V	415V	500V	600V	660V		
S	50	SA54B	4	5, 10, 15, 20, 30, 40, 50	660	10	10	7.5	7.5	5	2.5	–	–	
	100	SA104R	4	15, 20, 30, 40, 50, 60, 75, 100	660	85	85	50	45	35	25	–	–	
	225	SA204R	4	125, 150, 175, 200, 225	660	85	85	50	50	35	25	–	–	
	400	SA404HA	4	250, 300, 350, 400	660	85	85	45	45	35	30	–	–	
	600	SA604H	4	500, 600	660	85	85	45	45	35	30	–	–	
	800	SA804H	4	700, 800	660	85	85	45	45	35	30	–	–	
	1000	S1004	4	1000	660	85	85	50	50	35	30	30	–	
	1200	S1204	4	1200	660	85	85	50	50	35	30	30	–	
E	100	EA104B	4	50, 60, 75, 100	660	25	25	15	10	7.5	5	–	–	
F	50	F51B	1	15, 20, 30, 40, 50	300	2.5	3	–	3	–	–	–	–	
	50	F52B	2	15, 20, 30, 40, 50	300	5	3	–	3	–	–	–	–	
	50	F53B	3	15, 20, 30, 40, 50	300	5	3	–	–	–	–	–	–	
	100	F102B	2	60, 75, 100	300	5.5	3	–	–	–	–	–	–	
	100	F103B	3	60, 75, 100	300	5.5	3	–	–	–	–	–	–	

Molded Case Circuit Breakers

Breaking capacities

■ IEC 60947-2

Series	Breaker ampere frame	Basic type	Pole	Rated current (A)	Insulation voltage Ui (V)	Breaking capacity (kA)[Icu/lcs] IEC60947-2					
						AC 230V	400V	440V	500V	600V	DC 250V
L	50	LA53B	3	5, 10	660	100/50	60/30	50/25	42/21	–	–
H	50	H52BA	2	15, 20, 30, 40, 50	690	125/32	65/17	65/17	35/9	25/7	40/10
	50	H53BA	3	15, 20, 30, 40, 50	690	125/32	65/17	65/17	35/9	25/7	40/10
	100	H102BA	2	15, 20, 30, 40, 50, 60, 75, 100	690	125/32	65/17	65/17	35/9	25/7	40/10
	100	H103BA	3	15, 20, 30, 40, 50, 60, 75, 100	690	125/32	65/17	65/17	35/9	25/7	40/10
	225	H202BA	2	125, 150, 175, 200, 225	690	125/32	65/17	65/17	35/9	25/7	40/10
	225	H203BA	3	125, 150, 175, 200, 225	690	125/32	65/17	65/17	35/9	25/7	40/10
	400	H402B	2	250, 300, 350, 400	690	125/63	65/33	65/33	42/21	35/18	40/20
	400	H403B	3	250, 300, 350, 400	690	125/63	65/33	65/33	42/21	35/18	40/20
	400	H403R	3	250, 300, 350, 400	690	125/63	125/63	125/63	85/43	–	40/20
	600	H603B	3	500, 600	690	125/63	65/33	65/33	42/21	35/18	40/20
	600	H603R	3	500, 600	690	125/63	125/63	125/63	85/43	–	40/20
	800	H803B	3	700, 800	690	125/63	65/33	65/33	42/21	35/18	40/20
	800	H803R	3	700, 800	690	125/63	125/63	125/63	85/43	–	40/20

■ UL489 Listed

Series	Breaker ampere frame	Basic type	Pole	Rated current (A)	Insulation voltage Ui (V)	Breaking capacity (kA)[Icu/lcs] IEC60947-2 JIS C8201-2										UL489 (cUL)		
						AC		IEC60947-2						JIS C8201-2		Rated voltage (V)	Breaking capacity (kA)	
						230V	380V	400V	415V	440V	500V	600V	250V	240	480Y/277		480	
S	50	SA52RCUL	2	3, 5, 10, 15, 20, 30, 40, 50	690	25/13	10/5	10/5	10/5	10/5	7.5/4	5/3	–	240	14	–	–	
	50	SA53RCUL	3	3, 5, 10, 15, 20, 30, 40, 50	690	25/13	10/5	10/5	10/5	10/5	7.5/4	5/3	–	240	14	–	–	
	100	SA102CUL	2	15, 20, 30, 40, 50, 60, 70, 75, 80, 90, 100	690	50/25	30/8	30/8	30/8	25/7	15/4	–	15/8	240	35	–	–	
	100	SA103CUL	3	15, 20, 30, 40, 50, 60, 70, 75, 80, 90, 100	690	50/25	30/8	30/8	30/8	25/7	15/4	–	15/8	240	35	–	–	
	100	SA102RCUL	2	15, 20, 30, 40, 50, 60, 70, 75, 80, 90, 100	690	100/50	50/13	50/13	50/13	50/13	30/8	–	40/20	480Y/277	85	25	–	
	100	SA103RCUL	3	15, 20, 30, 40, 50, 60, 70, 75, 80, 90, 100	690	100/50	50/13	50/13	50/13	50/13	30/8	–	40/20	480Y/277	85	25	–	
	225	SA202CUL	2	125, 150, 175, 200, 225	690	50/25	30/8	30/8	30/8	25/7	15/4	–	15/8	240	35	–	–	
	225	SA203CUL	3	125, 150, 175, 200, 225	690	50/25	30/8	30/8	30/8	25/7	15/4	–	15/8	240	35	–	–	
	225	SA202RCUL	2	125, 150, 175, 200, 225	690	100/50	50/13	50/13	50/13	50/13	30/8	–	40/20	480Y/277	85	25	–	
	225	SA203RCUL	3	125, 150, 175, 200, 225	690	100/50	50/13	50/13	50/13	50/13	30/8	–	40/20	480Y/277	85	25	–	
	400	SA402CUL	2	250, 300, 350, 400	690	50/25	35/18	35/18	35/18	35/18	22/11	–	20/10	480	42	25	25	
	400	SA403CUL	3	250, 300, 350, 400	690	50/25	35/18	35/18	35/18	35/18	22/11	–	20/10	480	42	25	25	
	400	SA402RCUL	2	250, 300, 350, 400	690	85/43	50/25	50/25	50/25	50/25	35/18	30/15	40/20	480	85	50	50	
	400	SA403RCUL	3	250, 300, 350, 400	690	85/43	50/25	50/25	50/25	50/25	35/18	30/15	40/20	480	85	50	50	
	600	SA603RCUL	3	500, 600	690	85/43	50/25	50/25	50/25	50/25	35/18	30/15	40/20	480	85	50	50	
	800	SA803RCUL	3	700, 800	690	85/43	50/25	50/25	50/25	50/25	35/18	30/15	40/20	480	85	50	50	
	E	100	EA102CUL	2	60, 70, 75, 80, 90, 100	690	25/13	10/5	10/5	10/5	10/5	7.5/4	5/3	–	240	14	–	–
		100	EA103CUL	3	60, 70, 75, 80, 90, 100	690	25/13	10/5	10/5	10/5	10/5	7.5/4	5/3	–	240	14	–	–

Molded Case Circuit Breakers

Quick reference guide

Line protection

■ S series/2, 3-pole IEC and CE marking conformed types

Frame	30A		50A					
Pole	2	3	2	3	2	3		
Type	SA32C□-CE		SA33C□-CE	SA52C□-CE	SA53C□-CE	SA52RC□-CE	SA53RC□-CE	
Rated current (A)	3, 5, 10, 15, 20, 30		5, 10, 15, 20, 30, 40, 50		10, 15, 20, 30, 40, 50			
Rated insulation voltage (V AC)	690		690		690			
[IEC 60947-2, JIS C8201-2] (V DC)	250 *2		250 *2		250 *2			
Rated breaking capacity (kA)	600V AC	–	2.5/2		5/3			
[IEC 60947-2, JIS C8201-2] (Icu/Ics) *1	500V AC	1.5/1	5/3		7.5/4			
	440V AC	2.5/2	7.5/4		10/5			
	415V AC	2.5/2	7.5/4		10/5			
	400V AC	2.5/2	7.5/4		10/5			
	380V AC	2.5/2	7.5/4		10/5			
	230V AC	5/3	10/5		25/13			
	250V DC	2.5/2	5/3		5/3			
Rated operating voltage [UL508] (V AC)	550		600		600			
Dimensions (mm)	a	50	75	50	75	50	75	
	b	100	100	100	100	100	100	
	c	60	60	60	60	60	60	
	d	84	84	84	84	84	84	
Mass (kg) Front mounting type	0.4		0.5		0.4		0.5	
Tripping device	Hydraulic-magnetic		Hydraulic-magnetic		Hydraulic-magnetic		Hydraulic-magnetic	
Front mounting, front connection	No-mark	●	●	●	●	●	●	
Front mounting, rear connection	X	●	●	●	●	●	●	
Flush mounting, rear connection	E	●	●	●	●	●	●	
Flush mounting, top & bottom connection	Y	●	●	●	●	●	●	
Plug-in mounting	P	●	●	●	●	●	●	
IEC 35mm wide rail mounting		●	●	●	●	●	●	
Internal accessories		Page 06/88						
Alarm switch	K	BZ6KR10C	BZ6K□10C	BZ6KR10C	BZ6K□10C	BZ6KR10C	BZ6K□10C	
Alarm switch with terminal block	KA	BZ6KR10CA	BZ6K□10CA	BZ6KR10CA	BZ6K□10CA	BZ6WR10CA	BZ6K□10CA	
Auxiliary switch	W	BZ6WR10C	BZ6W□10C	BZ6WR10C	BZ6W□10C	BZ6WR10C	BZ6W□10C	
Auxiliary switch with terminal block	WA	BZ6WR10CA	BZ6W□10CA	BZ6WR10CA	BZ6W□10CA	BZ6WR10CA	BZ6W□10CA	
Undervoltage trip	R	BZ6R□10C	BZ6R□10C	BZ6R□10C	BZ6R□10C	BZ6R□10C	BZ6R□10C	
Shunt trip	F	BZ6F□10C	BZ6F□10C	BZ6F□10C	BZ6F□10C	BZ6F□10C	BZ6F□10C	
Shunt trip with terminal block	FA	BZ6F□10CA	BZ6F□10CA	BZ6F□10CA	BZ6F□10CA	BZ6F□10CA	BZ6F□10CA	
External accessories								
Motor operating mechanism	M	–	▲	–	▲	–	▲	
Handle padlocking device Cap type	Q1	–	–	–	–	–	–	
Plate type	Q2	▲	▲	▲	▲	▲	▲	
Mechanical interlocking device	M1	BZ6M110C2	BZ6M110C3	BZ6M110C2	BZ6M110C3	BZ6M110C2	BZ6M110C3	
	M2	BZ6M210C2	BZ6M210C3	BZ6M210C2	BZ6M210C3	BZ6M210C2	BZ6M210C3	
	M3	BZ6M310C2	BZ6M310C3	BZ6M310C2	BZ6M310C3	BZ6M310C2	BZ6M310C3	
Operating handle N-type	N	BZ6N10C	BZ6N10C	BZ6N10C	BZ6N10C	BZ6N10C	BZ6N10C	
Operating handle V-type	V	BZ6V10C	BZ6V10C	BZ6V10C	BZ6V10C	BZ6V10C	BZ6V10C	
Steel enclosure Direct operating	C	BZ6C10C2	BZ6C10C3	BZ6C10C2	BZ6C10C3	BZ6C10C2	BZ6C10C3	
Dustproof steel enclosure Handle operating	CV	BZ6CV10C	BZ6CV10C	BZ6CV10C	BZ6CV10C	BZ6CV10C	BZ6CV10C	
Rainproof steel enclosure Handle operating	CW	BZ6CW10C	BZ6CW10C	BZ6CW10C	BZ6CW10C	BZ6CW10C	BZ6CW10C	
Terminal cover Short	TS	BZ6TS10C2	BZ6TS10C3	BZ6TS10C2	BZ6TS10C3	BZ6TS10C2	BZ6TS10C3	
Terminal cover Long	TB	BZ6TB10C2	BZ6TB10C3	BZ6TB10C2	BZ6TB10C3	BZ6TB10C2	BZ6TB10C3	
Insulation barrier Interphase *3	B	BZ6B10C	BZ6B10C	BZ6B10C	BZ6B10C	BZ6B10C	BZ6B10C	
Insulation barrier Earth	BL	BZ6BL10C2	BZ6BL10C3	BZ6BL10C2	BZ6BL10C3	BZ6BL10C2	BZ6BL10C3	
Handle locking cover	L	BZ6L10C	BZ6L10C	BZ6L10C	BZ6L10C	BZ6L10C	BZ6L10C	
Flat terminal	S	BZ6S10C502	BZ6S10C503	BZ6S10C502	BZ6S10C503	BZ6S10C502	BZ6S10C503	

Notes: *1 Icu: Rated ultimate short-circuit breaking capacity

Ics: Rated service short-circuit breaking capacity

*2 Specify DC only when ordering circuit breakers for DC circuit.

*3 Interphase insulation barriers are standard provided for the front mounting type breakers of 50AF and over.

● Available – Not available ▲ Factory-mounted accessory

■ S series/2, 3-pole IEC and CE marking conformed types

Frame	60A			
Pole	2	3	2	3
Type	SA62C□-CE		SA63C□-CE	
Rated current (A)	60		60	
Rated insulation voltage (V AC)	690		690	
[IEC 60947-2, JIS C8201-2] (V DC)	250 *2		250 *2	
Rated breaking capacity (kA)	600V AC 2.5/2		5/3	
[IEC 60947-2, JIS C8201-2] (Icu/Ics) *1	500V AC 5/3		7.5/4	
	440V AC 7.5/4		10/5	
	415V AC 7.5/4		10/5	
	400V AC 7.5/4		10/5	
	380V AC 7.5/4		10/5	
	230V AC 10/5		25/13	
	250V DC 5/3		5/3	
Rated operating voltage [UL508] (V AC)	600		600	
Dimensions (mm)	a	50	75	50
	b	100	100	100
	c	60	60	60
	d	84	84	84
Mass (kg) Front mounting type	0.4		0.6	
Tripping device	Hydraulic-magnetic		Hydraulic-magnetic	
Front mounting, front connection	No-mark	●	●	●
Front mounting, rear connection	X	●	●	●
Flush mounting, rear connection	E	●	●	●
Flush mounting, top & bottom connection	Y	●	●	●
Plug-in mounting	P	●	●	●
IEC 35mm wide rail mounting		●	●	●
Internal accessories	Page 06/88			
Alarm switch	K	BZ6KR10C	BZ6K□10C	BZ6KR10C
Alarm switch with terminal block	KA	BZ6KR10CA	BZ6K□10CA	BZ6KR10CA
Auxiliary switch	W	BZ6WR10C	BZ6W□10C	BZ6WR10C
Auxiliary switch with terminal block	WA	BZ6WR10CA	BZ6W□10CA	BZ6WR10CA
Undervoltage trip	R	BZ6R□10C	BZ6R□10C	BZ6R□10C
Shunt trip	F	BZ6F□10C	BZ6F□10C	BZ6F□10C
Shunt trip with terminal block	FA	BZ6F□10CA	BZ6F□10CA	BZ6F□10CA
External accessories				
Motor operating mechanism	M	–	▲	–
Handle padlocking device Cap type	Q1	–	–	–
Plate type	Q2	▲	▲	▲
Mechanical interlocking device	M1	BZ6M110C2	BZ6M110C3	BZ6M110C2
	M2	BZ6M210C2	BZ6M210C3	BZ6M210C2
	M3	BZ6M310C2	BZ6M310C3	BZ6M310C2
Operating handle N-type	N	BZ6N10C	BZ6N10C	BZ6N10C
Operating handle V-type	V	BZ6V10C	BZ6V10C	BZ6V10C
Steel enclosure Direct operating	C	BZ6C10C2	BZ6C10C3	BZ6C10C2
Dustproof steel enclosure Handle operating	CV	BZ6CV10C	BZ6CV10C	BZ6CV10C
Rainproof steel enclosure Handle operating	CW	BZ6CW10C	BZ6CW10C	BZ6CW10C
Terminal cover Short	TS	BZ6TS10C2	BZ6TS10C3	BZ6TS10C2
Terminal cover Long	TB	BZ6TB10C2	BZ6TB10C3	BZ6TB10C2
Insulation barrier Interphase *3	B	BZ6B10C	BZ6B10C	BZ6B10C
Insulation barrier Earth	BL	BZ6BL10C2	BZ6BL10C3	BZ6BL10C2
Handle locking cover	L	BZ6L10C	BZ6L10C	BZ6L10C
Flat terminal	S	BZ6S10C1002	BZ6S10C1003	BZ6S10C1002

Notes: *1 Icu: Rated ultimate short-circuit breaking capacity
Ics: Rated service short-circuit breaking capacity
*2 Specify DC only when ordering circuit breakers for DC circuit.
*3 Interphase insulation barriers are standard provided for the front mounting type breakers of 50AF and over.

● Available – Not available ▲ Factory-mounted accessory

Molded Case Circuit Breakers

Quick reference guide

Line protection

■ S series/2, 3-pole IEC and CE marking conformed types

Frame	100A				225A							
Pole	2	3	2	3	2	3						
Type	SA102C□-CE		SA103C□-CE		SA102RC□-CE		SA103RC□-CE		SA202C□-CE		SA203C□-CE	
Rated current (A)	15, 20, 30, 40, 50, 60, 75, 100		15, 20, 30, 40, 50, 60, 75, 100		125, 150, 175, 200, 225							
Rated insulation voltage (V AC)	690		690		690							
[IEC 60947-2, JIS C8201-2] (V DC)	250		250		250							
Rated breaking capacity (kA)	600V AC		-		-							
[IEC 60947-2, JIS C8201-2] (Icu/Ics) *1	500V AC		15/4		30/8		15/4					
	440V AC		25/7		50/13		25/7					
	415V AC		30/8		50/13		30/8					
	400V AC		30/8		50/13		30/8					
	380V AC		30/8		50/13		30/8					
	230V AC		50/25		100/50		50/25					
	250V DC		15/8		40/20		15/8					
Rated operating voltage [UL508] (V AC)	-		-		-							
Dimensions (mm)	a	60	90	90	90	105	105					
	b	155	155	155	155	165	165					
	c	60	60	60	60	60	60					
	d	82	82	82	82	84	84					
Mass (kg) Front mounting type	0.7		1.1		1.1		1.2		1.1		1.3	
Tripping device	Thermal-magnetic		Thermal-magnetic		Thermal-magnetic		Thermal-magnetic					
Front mounting, front connection	No-mark	●	●	●	●	●	●	●	●	●	●	
Front mounting, rear connection	X	●	●	●	●	●	●	●	●	●	●	
Flush mounting, rear connection	E	●	●	●	●	●	●	●	●	●	●	
Flush mounting, top & bottom connection	Y	-	-	-	-	-	-	-	-	-	-	
Plug-in mounting	P	●	●	●	●	●	●	●	●	●	●	
IEC 35mm wide rail mounting		-	-	-	-	-	-	-	-	-	-	
Internal accessories	Page 06/88											
Alarm switch	K	BZ6K□30C	BZ6K□30C	BZ6K□30C	BZ6K□30C	BZ6K□30C	BZ6K□40C	BZ6K□40C	BZ6K□40C	BZ6K□40C	BZ6K□40C	
Alarm switch with terminal block	KA	BZ6K□30CA	BZ6K□30CA	BZ6K□30CA	BZ6K□30CA	BZ6K□30CA	BZ6W□40CA	BZ6K□40CA	BZ6K□40CA	BZ6K□40CA	BZ6K□40CA	
Auxiliary switch	W	BZ6W□30C	BZ6W□30C	BZ6W□30C	BZ6W□30C	BZ6W□30C	BZ6W□40C	BZ6W□40C	BZ6W□40C	BZ6W□40C	BZ6W□40C	
Auxiliary switch with terminal block	WA	BZ6W□30CA	BZ6W□30CA	BZ6W□30CA	BZ6W□30CA	BZ6W□30CA	BZ6W□40CA	BZ6W□40CA	BZ6W□40CA	BZ6W□40CA	BZ6W□40CA	
Undervoltage trip	R	▲	▲	▲	▲	▲	▲	▲	▲	▲	▲	
Shunt trip	F	BZ6F□30C	BZ6F□30C	BZ6F□30C	BZ6F□30C	BZ6F□30C	BZ6F□40C	BZ6F□40C	BZ6F□40C	BZ6F□40C	BZ6F□40C	
Shunt trip with terminal block	FA	BZ6F□30CA	BZ6F□30CA	BZ6F□30CA	BZ6F□30CA	BZ6F□30CA	BZ6F□40CA	BZ6F□40CA	BZ6F□40CA	BZ6F□40CA	BZ6F□40CA	
External accessories												
Motor operating mechanism	M	-	▲	▲	▲	▲	▲	▲	▲	▲	▲	
Handle padlocking device Cap type	Q1	-	-	-	-	-	-	-	-	-	-	
Plate type	Q2	-	-	-	-	-	-	-	-	-	-	
Mechanical interlocking device	M1	BZ6M130C2	BZ6M130C3	BZ6M130C3	BZ6M130C3	BZ6M130C3	BZ6M140C	BZ6M140C	BZ6M140C	BZ6M140C	BZ6M140C	
	M2	BZ-M230C-2	BZ-M230C-3	BZ-M230C-3	BZ-M230C-3	BZ-M230C-3	BZ-M240C	BZ-M240C	BZ-M240C	BZ-M240C	BZ-M240C	
	M3	BZ-M330C-2	BZ-M330C-3	BZ-M330C-3	BZ-M330C-3	BZ-M330C-3	BZ-M340C	BZ-M340C	BZ-M340C	BZ-M340C	BZ-M340C	
Operating handle N-type	N	BZ-N30C	BZ-N30C	BZ-N30C	BZ-N30C	BZ-N30C	BZ-N40C	BZ-N40C	BZ-N40C	BZ-N40C	BZ-N40C	
Operating handle V-type	V	BZ6V30C	BZ6V30C	BZ6V30C	BZ6V30C	BZ6V30C	BZ6V40C	BZ6V40C	BZ6V40C	BZ6V40C	BZ6V40C	
Steel enclosure Direct operating	C	BZ6C30C2	BZ6C30C3	BZ6C30C3	BZ6C30C3	BZ6C30C3	BZ-C40B	BZ-C40B	BZ-C40B	BZ-C40B	BZ-C40B	
Dustproof steel enclosure Handle operating	CV	BZ-CV30C	BZ-CV30C	BZ-CV30C	BZ-CV30C	BZ-CV30C	BZ-CV40C	BZ-CV40C	BZ-CV40C	BZ-CV40C	BZ-CV40C	
Rainproof steel enclosure Handle operating	CW	BZ-CW30C	BZ-CW30C	BZ-CW30C	BZ-CW30C	BZ-CW30C	BZ-CW40C	BZ-CW40C	BZ-CW40C	BZ-CW40C	BZ-CW40C	
Terminal cover Short	TS	BZ-TS30B-2	BZ-TS30B-3	BZ-TS30B-3	BZ-TS30B-3	BZ-TS30B-3	BZ-TS40B	BZ-TS40B	BZ-TS40B	BZ-TS40B	BZ-TS40B	
Terminal cover Long	TB	BZ-TB30B-2	BZ-TB30B-3	BZ-TB30B-3	BZ-TB30B-3	BZ-TB30B-3	BZ-TB40B	BZ-TB40B	BZ-TB40B	BZ-TB40B	BZ-TB40B	
Insulation barrier Interphase *2	B	BZ-B30B	BZ-B30B	BZ-B30B	BZ-B30B	BZ-B30B	BZ-B40B	BZ-B40B	BZ-B40B	BZ-B40B	BZ-B40B	
Insulation barrier Earth	BL	BZ-BL30B-2	BZ-BL35B	BZ-BL35B	BZ-BL35B	BZ-BL35B	BZ-BL40B	BZ-BL40B	BZ-BL40B	BZ-BL40B	BZ-BL40B	
Handle locking cover	L	BZ6L30C	BZ6L30C	BZ6L30C	BZ6L30C	BZ6L30C	BZ6L40C	BZ6L40C	BZ6L40C	BZ6L40C	BZ6L40C	
Flat terminal	S	BZ-S35B-1002	BZ-S35B-1003	BZ-S35B-1002	BZ-S35B-1003	BZ-S35B-1003	BZ-S50B-2252	BZ-S50B-2252	BZ-S50B-2252	BZ-S50B-2252	BZ-S50B-2252	

Notes: *1 Icu: Rated ultimate short-circuit breaking capacity

Ics: Rated service short-circuit breaking capacity

*2 Interphase insulation barriers are standard provided for the front mounting type breakers of 50AF and over.

● Available - Not available ▲ Factory-mounted accessory

■ S series/2, 3-pole IEC and CE marking conformed types

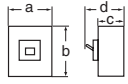
Frame	225A		400A	
Pole	2	3	2	3
Type	SA202RC□-CE		SA203RC□-CE	
Rated current (A)	125, 150, 175, 200, 225		250, 300, 350, 400	
Rated insulation voltage (V AC)	690		690	
[IEC 60947-2, JIS C8201-2] (V DC)	250		250	
Rated breaking capacity (kA)	600V AC –		–	
[IEC 60947-2, JIS C8201-2] (Icu/Ics) *1	500V AC 30/8		22/11	
	440V AC 50/13		35/18	
	415V AC 50/13		35/18	
	400V AC 50/13		35/18	
	380V AC 50/13		35/18	
	230V AC 100/50		50/25	
	250V DC 40/20		20/10	
Rated operating voltage [UL508] (V AC)	–		–	
Dimensions (mm)	a	105	105	140
	b	165	165	257
	c	60	60	103
	d	84	84	146
				
Mass (kg) Front mounting type		1.1	1.3	4.5
Tripping device		Thermal-magnetic		Thermal-magnetic
Front mounting, front connection	No-mark	●	●	●
Front mounting, rear connection	X	●	●	●
Flush mounting, rear connection	E	●	●	●
Flush mounting, top & bottom connection	Y	–	–	–
Plug-in mounting	P	●	●	●
IEC 35mm wide rail mounting		–	–	–
Internal accessories		BZ6K□40C		BZ-K70B
Alarm switch	K	BZ6K□40C	BZ6K□40C	BZ-K70B
Alarm switch with terminal block	KA	BZ6K□40CA	BZ6K□40CA	BZ-K70BA
Auxiliary switch	W	BZ6W□40C	BZ6W□40C	BZ-W70B
Auxiliary switch with terminal block	WA	BZ6W□40CA	BZ6W□40CA	BZ-W70BA
Undervoltage trip	R	▲	▲	BZ-R70B-□
Shunt trip	F	BZ6F□40C	BZ6F□40C	BZ-F70B-□
Shunt trip with terminal block	FA	BZ6F□40CA	BZ6F□40CA	BZ-F70BA-□
External accessories		▲		▲
Motor operating mechanism	M	▲	▲	▲
Handle padlocking device Cap type	Q1	–	–	▲
Plate type	Q2	–	–	▲
Mechanical interlocking device	M1	BZ6M140C	BZ6M140C	BZ-M160C
	M2	BZ-M240C	BZ-M240C	BZ-M260C
	M3	BZ-M340C	BZ-M340C	BZ-M360C
Operating handle N-type	N	BZ-N40C	BZ-N40C	BZ-N60C
Operating handle V-type	V	BZ6V40C	BZ6V40C	BZ6V60C
Steel enclosure Direct operating	C	BZ-C40B	BZ-C40B	BZ-C60B
Dustproof steel enclosure Handle operating	CV	BZ-CV40C	BZ-CV40C	BZ-CV60C
Rainproof steel enclosure Handle operating	CW	BZ-CW40C	BZ-CW40C	BZ-CW60C
Terminal cover Short	TS	BZ-TS40B	BZ-TS40B	–
Terminal cover Long	TB	BZ-TB40B	BZ-TB40B	BZ-TB60B
Insulation barrier Interphase *2	B	BZ-B40B	BZ-B40B	B-43A
Insulation barrier Earth	BL	BZ-BL40B	BZ-BL40B	–
Handle locking cover	L	BZ6L40C	BZ6L40C	BZ-L70B
Flat terminal	S	BZ-S50B-2252	BZ-S50B-2253	–

Notes: *1 Icu: Rated ultimate short-circuit breaking capacity
Ics: Rated service short-circuit breaking capacity
*2 Interphase insulation barriers are standard provided for the front mounting type breakers of 50AF and over.

● Available – Not available ▲ Factory-mounted accessory

Molded Case Circuit Breakers

Quick reference guide

Line protection

■ S series/2, 3-pole IEC and CE marking conformed types

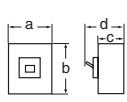
Frame	400A		600A	800A
Pole	2		3	3
Type	SA402RC□-CE		SA403RC□-CE	SA603RC□-CE
Rated current (A)	250, 300, 350, 400		500, 600	700, 800
Rated insulation voltage (V AC)	690		690	690
[IEC 60947-2, JIS C8201-2] (V DC)	250		250	250
Rated breaking capacity (kA)	600V AC	30/15	30/15	30/15
[IEC 60947-2, JIS C8201-2] (Icu/Ics) *1	500V AC	35/18	35/18	35/18
	440V AC	50/25	50/25	50/25
	415V AC	50/25	50/25	50/25
	400V AC	50/25	50/25	50/25
	380V AC	50/25	50/25	50/25
	230V AC	85/43	85/43	85/43
	250V DC	40/20	40/20	40/20
Rated operating voltage [UL508] (V AC)	-		-	-
Dimensions (mm)	a	140	140	210
	b	257	257	275
	c	103	103	103
	d	146	146	146
				
Mass (kg) Front mounting type	4.5		5	9
Tripping device	Thermal-magnetic		Thermal-magnetic	Thermal-magnetic
Front mounting, front connection	No-mark	●	●	●
Front mounting, rear connection	X	●	●	●
Flush mounting, rear connection	E	●	●	●
Flush mounting, top & bottom connection	Y	-	-	-
Plug-in mounting	P	●	●	●
IEC 35mm wide rail mounting		-	-	-
Internal accessories	Page 06/88			
Alarm switch	K	BZ-K70B	BZ-K70B	BZ-K70B
Alarm switch with terminal block	KA	BZ-K70BA	BZ-K70BA	BZ-K70BA
Auxiliary switch	W	BZ-W70B	BZ-W70B	BZ-W70B
Auxiliary switch with terminal block	WA	BZ-W70BA	BZ-W70BA	BZ-W70BA
Undervoltage trip	R	BZ-R70B-□	BZ-R70B-□	BZ-R70B-□
Shunt trip	F	BZ-F70B-□	BZ-F70B-□	BZ-F70B-□
Shunt trip with terminal block	FA	BZ-F70BA-□	BZ-F70BA-□	BZ-F70BA-□
External accessories				
Motor operating mechanism	M	▲	▲	▲
Handle padlocking device Cap type	Q1	▲	▲	▲
Plate type	Q2	▲	▲	▲
Mechanical interlocking device	M1	BZ-M160C	BZ-M160C	BZ-M170C
	M2	BZ-M260C	BZ-M260C	BZ-M270C
	M3	BZ-M360C	BZ-M360C	BZ-M370C
Operating handle N-type	N	BZ-N60C	BZ-N60C	BZ-N70C
Operating handle V-type	V	BZ6V60C	BZ6V60C	BZ6V70C
Steel enclosure Direct operating	C	BZ-C60B	BZ-C60B	BZ-C70B
Dustproof steel enclosure Handle operating	CV	BZ-CV60C	BZ-CV60C	BZ-CV70C
Rainproof steel enclosure Handle operating	CW	BZ-CW60C	BZ-CW60C	-
Terminal cover Short	TS	-	-	-
Terminal cover Long	TB	BZ-TB60B	BZ-TB60B	BZ-TB70B
Insulation barrier Interphase *2	B	B-43A	B-43A	B-43A
Insulation barrier Earth	BL	-	-	-
Handle locking cover	L	BZ-L70B	BZ-L70B	BZ-L70B
Flat terminal	S	-	-	-

Notes: *1 Icu: Rated ultimate short-circuit breaking capacity
Ics: Rated service short-circuit breaking capacity

*2 Interphase insulation barriers are standard provided for the front mounting type breakers of 50AF and over.

● Available - Not available ▲ Factory-mounted accessory

Molded Case Circuit Breakers

Quick reference guide

Line protection

■ S series/3, 4-pole IEC and CE marking conformed types

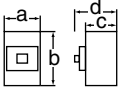
Frame		1000A		1200A		1600A		
Pole		3	4	3	4	3	4	
Type		SA1003E	SA1004E	SA1203E	SA1204E	SA1603E	SA1604E	
Rated current(A)		Adjustable 500—600—700—800 —900—1000		Adjustable 600—700—800—1000 —1200		Adjustable 800—900—1000—1200 —1400—1600		
Rated insulation voltage(V)		AC DC	690 —	690 —	690 —	690 —	690 —	
Rated breaking capacity (kA)	JIS C8370 (sym)	550V AC 460V AC 220V AC 250V DC	50 65 100 —	50 65 100 —	50 65 100 —	65 85 130 —	65 85 130 —	
	IEC 60947-2 (Icu/Ics) BS 4752 (sym)*	690V AC 660V AC 600V AC 500V AC 440V AC 400V AC 230V AC 250V DC	25/19 25/19 25/19 45/34 65/49 65/49 100/75 —	25/19 25/19 25/19 45/34 65/49 65/49 100/75 —	25/19 25/19 25/19 45/34 65/49 65/49 100/75 —	45/34 45/34 45/34 65/49 85/64 85/64 125/94 —	45/34 45/34 45/34 65/49 85/64 85/64 125/94 —	
Dimensions (mm)		a	210	280	210	280	210	280
		b	370		370		370	
		c	120		120		140	
		d	171		171		191	
Protection function	Long-time delay tripping time (s)	5-30 (at 6In) (Adjustable)						
	Short-time delay tripping current (A)	2In-10In (Adjustable)						
	Short-time delay tripping time (s)	0.1-0.3 (Adjustable)						
	Instantaneous tripping current (kA)	3.0-12 (Adjustable)		3.75-15 (Adjustable)		4.8-19.2 (Adjustable)		
	Ground fault current tripping or pre-alarm	●		●		●		
Mass(kg) Front mounting, front connection		22	28	22	28	27	35	
Tripping device		Solid-state		Solid-state		Solid-state		
Trip button		Provided		Provided		Provided		
Mounting	Front mounting, front connection	No mark	●		● Bar stud	●		
	Front mounting, rear connection	X	● Bar Stud		● Bar stud	● Bar stud		
	Flush mounting, rear connection	E	● Bar Stud		●	● Bar stud		
	Plug-in mounting	P	●		●	—		
Internal accessories	Auxiliary switch	W	●		●	●		
	Alarm switch	K	●		●	●		
	Shunt trip	F	●		●	●		
	Undervoltage trip	R	●		●	●		
External accessories	Motor operating mechanism	M	●		●	●		
	Lead-wire terminal block	—	●		●	●		

● Available — Not available

06

Molded Case Circuit Breakers

Quick reference guide

Line protection

■ S series/4-pole

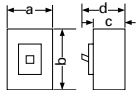
Frame		50A	100A	225A
Pole		4	4	4
Type		SA54B	SA104R	SA204R
Rated current (Amps) Ambient temp.: 40°C for general use		5, 10, 15, 20 30, 40, 50	15, 20, 30, 40 50, 60, 75, 100	125, 150, 175 200, 225
Rated insulation voltage Ui (Volts) AC		660	660	660
Rated breaking capacity (kA)	JIS C8370 sym	550V AC 460V AC 220V AC	2.5 7.5 10	35 42 85
Dimensions (mm)		a b c d	100 130 60 80	120 155 82 104
Mass (kg)	Front mounting type	0.8	1.9	2.5
Tripping device		Hydraulic-magnetic	Thermal-magnetic	Thermal-magnetic
Trip button		Provided	Provided	Provided
Front mounting, front connection	No-mark	●	●	●
Front mounting, rear connection	X	●	●	●
Flush mounting, rear connection	E	●	●	●
Flush mounting, top & bottom connection	Y	●	—	—
Plug-in mounting	P	—	—	—
Draw-out	D	—	—	—
Internal accessories				
Alarm switch	K	BZ-K23B□	BZ-K35B□	BZ-K50B
Auxiliary switch	W	BZ-W23B□	BZ-W35B□	BZ-W50B
Undervoltage trip	R	—	—	—
Shunt trip	F	BZ-F23BT □	BZ-F35BT □	BZ-F50BT □
External accessories				
Motor operating mechanism	M	—	▲	▲
Padlocking device	Q	▲	▲	▲
Mechanical interlocking device	M1	BZ-M120C-4	BZ-M135C-4	BZ-M150C-4
Operating handle N type	N	BZ-N20C	BZ-N35B	BZ-N50B
Operating handle V, G type	V, G	BZ-V20C	BZ-G35C	BZ-G50C
Steel enclosure	C	—	—	—
Steel enclosure with V type handle	CV	—	—	—
Terminal cover Short	TS	BZ-TS20B-4	—	—
Terminal cover Long	TB	BZ-TB20B-4	BZ-TB35B-4	BZ-TB45B-4
Insulation barrier Interphase	B	—	—	—
Insulation barrier Earth	BL	—	—	—

Notes: • Handlelock cover is supplied on request (sold separately)

● Available — Not available ▲ Factory-mounted accessory

■ S series/4-pole

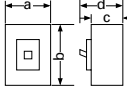
Frame		400A	600A	800A
Pole		4	4	4
Type		<i>Page 06/43</i> SA404HA	SA604H	SA804H
Rated current (Amps) Ambient temp.: 40°C for general use		250, 300 350, 400	500, 600	700, 800
Rated insulation voltage Ui (Volts) AC		660	660	660
Rated breaking capacity (kA)	JIS C8370	sym	550V AC 460V AC 220V AC	35 42 85
				35 42 85
				35 42 85
Dimensions (mm) <i>Page 06/57</i>		a	185	280
		b	257	275
		c	103	103
		d	134	149
Mass (kg)	Front mounting type	7.5	17.0	18.2
Tripping devices		Thermal-magnetic	Thermal-magnetic	Thermal-magnetic
Trip button		Provided	Provided	Provided
Front mounting, front connection	No-mark	●	●	●
	rear connection	X ●	●	●
Flush mounting, rear connection	E	●	●	●
	top & bottom connection	Y	—	—
Plug-in mounting	P	—	—	—
Draw-out	D	—	—	—
Internal accessories <i>Page 06/88</i>				
Alarm switch	K	▲	▲	▲
Auxiliary switch	W	▲	▲	▲
Undervoltage trip	R	▲	▲	▲
Shunt trip	F	▲	▲	▲
External accessories				
Motor operating mechanism	M	▲	▲	▲
Padlocking device	Q	▲	▲	▲
Mechanical interlocking device	M1	BZ-M144	BZ-M154	BZ-M154
Operating handle	N type	N	N-23A	N-41A
Operating handle	G type	G	G-22A	G-42A
Steel enclosure	C	—	—	—
Steel enclosure with G type handle	CG	—	—	—
Terminal cover	Inside panel use	A1	—	—
Terminal cover	Outside panel use	T1	—	—
Insulation barrier	Interphase	B	B-44A	B-44A
Insulation barrier	Earth	BL	—	—

Notes: *1 Specify the frequency when ordering circuit breaker for AC circuit.
Contact FUJI for DC circuit.

• Handlelock cover is supplied on request (sold separately)

● Available — Not available ▲ Factory-mounted accessory

Molded Case Circuit Breakers

Quick reference guide

Line protection

■ E series/2, 3-pole IEC and CE marking conformed types

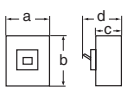
Frame	30A		50A			
Pole	2	3	2	3	2	3
Type	<i>Page 06/42</i> EA32AC□-CE EA33AC□-CE		EA52AC□-CE EA53AC□-CE		EA52C□-CE EA53C□-CE	
Rated current (A)	3, 5, 10, 15, 20, 30		5, 10, 15, 20, 30, 40, 50		5, 10, 15, 20, 30, 40, 50	
Rated insulation voltage (V AC)	500		500		690	
[IEC 60947-2, JIS C8201-2] (V DC)	-		-		250 *2	
Rated breaking capacity (kA)	600V AC	-	-	-	-	-
[IEC 60947-2, JIS C8201-2] (Icu/Ics) *1	500V AC	-	-	-	1.5/1	-
	440V AC	1.5/1	1.5/1	1.5/1	2.5/2	-
	415V AC	1.5/1	1.5/1	1.5/1	2.5/2	-
	400V AC	1.5/1	1.5/1	1.5/1	2.5/2	-
	380V AC	1.5/1	1.5/1	1.5/1	2.5/2	-
	230V AC	2.5/2	2.5/2	2.5/2	5/3	-
	250V DC	-	-	-	2.5/2	-
Rated operating voltage [UL508] (V AC)	<i>Page 06/37</i> 240		240		550	
Dimensions (mm)	a	50	75	50	75	50
	b	100	100	100	100	100
	c	60	60	60	60	60
	d	84	84	84	84	84
<i>Page 06/63</i>						
Mass (kg) Front mounting type	0.4	0.5	0.4	0.5	0.4	0.5
Tripping device	Hydraulic-magnetic		Hydraulic-magnetic		Hydraulic-magnetic	
Front mounting, front connection	No-mark	●	●	●	●	●
Front mounting, rear connection	X	●	●	●	●	●
Flush mounting, rear connection	E	●	●	●	●	●
Flush mounting, top & bottom connection	Y	●	●	●	●	●
Plug-in mounting	P	●	●	●	●	●
IEC 35mm wide rail mounting		●	●	●	●	●
Internal accessories	<i>Page 06/88</i>					
Alarm switch	K	BZ6KR10C	BZ6K□10C	BZ6KR10C	BZ6K□10C	BZ6KR10C
Alarm switch with terminal block	KA	BZ6KR10CA	BZ6K□10CA	BZ6KR10CA	BZ6K□10CA	BZ6KR10CA
Auxiliary switch	W	BZ6WR10C	BZ6W□10C	BZ6WR10C	BZ6W□10C	BZ6WR10C
Auxiliary switch with terminal block	WA	BZ6WR10CA	BZ6W□10CA	BZ6WR10CA	BZ6W□10CA	BZ6WR10CA
Undervoltage trip	R	BZ6R□10C	BZ6R□10C	BZ6R□10C	BZ6R□10C	BZ6R□10C
Shunt trip	F	BZ6F□10C	BZ6F□10C	BZ6F□10C	BZ6F□10C	BZ6F□10C
Shunt trip with terminal block	FA	BZ6F□10CA	BZ6F□10CA	BZ6F□10CA	BZ6F□10CA	BZ6F□10CA
External accessories						
Motor operating mechanism	M	-	▲	-	▲	-
Handle padlocking device Cap type	Q1	-	-	-	-	-
Plate type	Q2	▲	▲	▲	▲	▲
Mechanical interlocking device	M1	BZ6M110C2	BZ6M110C3	BZ6M110C2	BZ6M110C3	BZ6M110C2
	M2	BZ6M210C2	BZ6M210C3	BZ6M210C2	BZ6M210C3	BZ6M210C2
	M3	BZ6M310C2	BZ6M310C3	BZ6M310C2	BZ6M310C3	BZ6M310C2
Operating handle N-type	N	BZ6N10C	BZ6N10C	BZ6N10C	BZ6N10C	BZ6N10C
Operating handle V-type	V	BZ6V10C	BZ6V10C	BZ6V10C	BZ6V10C	BZ6V10C
Steel enclosure Direct operating	C	BZ6C10C2	BZ6C10C3	BZ6C10C2	BZ6C10C3	BZ6C10C2
Dustproof steel enclosure Handle operating	CV	BZ6CV10C	BZ6CV10C	BZ6CV10C	BZ6CV10C	BZ6CV10C
Rainproof steel enclosure Handle operating	CW	BZ6CW10C	BZ6CW10C	BZ6CW10C	BZ6CW10C	BZ6CW10C
Terminal cover Short	TS	BZ6TS10C2	BZ6TS10C3	BZ6TS10C2	BZ6TS10C3	BZ6TS10C2
Terminal cover Long	TB	BZ6TB10C2	BZ6TB10C3	BZ6TB10C2	BZ6TB10C3	BZ6TB10C2
Insulation barrier Interphase *3	B	BZ6B10C	BZ6B10C	BZ6B10C	BZ6B10C	BZ6B10C
Insulation barrier Earth	BL	BZ6BL10C2	BZ6BL10C3	BZ6BL10C2	BZ6BL10C3	BZ6BL10C2
Handle locking cover	L	BZ6L10C	BZ6L10C	BZ6L10C	BZ6L10C	BZ6L10C
Flat terminal	S	BZ6S10C502	BZ6S10C503	BZ6S10C502	BZ6S10C503	BZ6S10C502

Notes: *1 Icu: Rated ultimate short-circuit breaking capacity

Ics: Rated service short-circuit breaking capacity

*2 Specify DC only when ordering circuit breakers for DC circuit.

*3 Interphase insulation barriers are standard provided for the front mounting type breakers of 50AF and over. Except for EA50AC

● Available - Not available ▲ Factory-mounted accessory

■ E series/2, 3-pole IEC and CE marking conformed types

Frame	60A		100A		
Pole	2	3	3	2	3
Type	Page 06/42 EA62C□-CE		EA63C□-CE	EA103AC□-CE	EA102C□-CE EA103C□-CE
Rated current (A)	60		60, 75, 100	50, 60, 75, 100	
Rated insulation voltage (V AC)	690		500	690	
[IEC 60947-2, JIS C8201-2] (V DC)	250 *2		–	250 *2	
Rated breaking capacity (kA)	600V AC	–	–	5/3	
[IEC 60947-2, JIS C8201-2] (Icu/Ics) *1	500V AC	1.5/1	–	7.5/4	
	440V AC	2.5/2	–	10/5	
	415V AC	2.5/2	–	10/5	
	400V AC	2.5/2	1.5/1	10/5	
	380V AC	5/3	1.5/1	10/5	
	230V AC	5/3	5/3	25/13	
	250V DC	2.5/2	–	5/3	
Rated operating voltage [UL508] (V AC)	Page 06/37 550		240	600	
Dimensions (mm)	a	50	75	50	75
	b	100	100	100	100
	c	60	60	60	60
	d	84	84	84	84
Mass (kg) Front mounting type	0.4		0.6	0.4	0.6
Tripping device	Hydraulic-magnetic		Hydraulic-magnetic		
Front mounting, front connection	No-mark	●	●	●	●
Front mounting, rear connection	X	●	●	●	●
Flush mounting, rear connection	E	●	●	●	●
Flush mounting, top & bottom connection	Y	●	●	●	●
Plug-in mounting	P	●	●	●	●
IEC 35mm wide rail mounting		●	●	●	●
Internal accessories	Page 06/88				
Alarm switch	K	BZ6KR10C	BZ6K□10C	BZ6K□10C	BZ6KR10C BZ6K□10C
Alarm switch with terminal block	KA	BZ6KR10CA	BZ6K□10CA	BZ6K□10CA	BZ6KR10CA BZ6K□10CA
Auxiliary switch	W	BZ6WR10C	BZ6W□10C	BZ6W□10C	BZ6WR10C BZ6W□10C
Auxiliary switch with terminal block	WA	BZ6WR10CA	BZ6W□10CA	BZ6W□10CA	BZ6WR10CA BZ6W□10CA
Undervoltage trip	R	BZ6R□10C	BZ6R□10C	BZ6R□10C	BZ6R□10C
Shunt trip	F	BZ6F□10C	BZ6F□10C	BZ6F□10C	BZ6F□10C
Shunt trip with terminal block	FA	BZ6F□10CA	BZ6F□10CA	BZ6F□10CA	BZ6F□10CA
External accessories					
Motor operating mechanism	M	–	▲	▲	– ▲
Handle padlocking device Cap type	Q1	–	–	–	–
Plate type	Q2	▲	▲	▲	▲
Mechanical interlocking device	M1	BZ6M110C2	BZ6M110C3	BZ6M110C3	BZ6M110C2 BZ6M110C3
	M2	BZ6M210C2	BZ6M210C3	BZ6M210C3	BZ6M210C2 BZ6M210C3
	M3	BZ6M310C2	BZ6M310C3	BZ6M310C3	BZ6M310C2 BZ6M310C3
Operating handle N-type	N	BZ6N10C	BZ6N10C	BZ6N10C	BZ6N10C
Operating handle V-type	V	BZ6V10C	BZ6V10C	BZ6V10C	BZ6V10C
Steel enclosure Direct operating	C	BZ6C10C2	BZ6C10C3	BZ6C25C3	BZ6C25C2 BZ6C25C3
Dustproof steel enclosure Handle operating	CV	BZ6CV10C	BZ6CV10C	BZ6CV25C	BZ6CV25C BZ6CV25C
Rainproof steel enclosure Handle operating	CW	BZ6CW10C	BZ6CW10C	BZ6CW25C	BZ6CW25C BZ6CW25C
Terminal cover Short	TS	BZ6TS10C2	BZ6TS10C3	BZ6TS10C3	BZ6TS10C2 BZ6TS10C3
Terminal cover Long	TB	BZ6TB10C2	BZ6TB10C3	BZ6TB10C3	BZ6TB10C2 BZ6TB10C3
Insulation barrier Interphase *3	B	BZ6B10C	BZ6B10C	BZ6B10C	BZ6B10C
Insulation barrier Earth	BL	BZ6BL10C2	BZ6BL10C3	BZ6BL10C3	BZ6BL10C2 BZ6BL10C3
Handle locking cover	L	BZ6L10C	BZ6L10C	BZ6L10C	BZ6L10C
Flat terminal	S	BZ6S10C1002	BZ6S10C1003	BZ6S10C1003	BZ6S10C1002 BZ6S10C1003

Notes: *1 Icu: Rated ultimate short-circuit breaking capacity
Ics: Rated service short-circuit breaking capacity
*2 Specify DC only when ordering circuit breakers for DC circuit.
*3 Interphase insulation barriers are standard provided for the front mounting type breakers of 50AF and over. Except for EA100AC

● Available – Not available ▲ Factory-mounted accessory

Molded Case Circuit Breakers

Quick reference guide

Line protection

■ E series/2, 3-pole IEC and CE marking conformed types

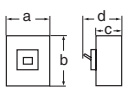
Frame	225A		400A		600A	
Pole	2	3	2	3	3	
Type	<i>Page 06/42</i> EA202C□-CE		EA203C□-CE	EA402C□-CE	EA403C□-CE	EA603C□-CE
Rated current (A)	125, 150, 175, 200, 225		250, 300, 350, 400		500, 600	
Rated insulation voltage (V AC)	690		690		690	
[IEC 60947-2, JIS C8201-2] (V DC)	250		250		250	
Rated breaking capacity (kA)	600V AC	–	–	–	–	
[IEC 60947-2, JIS C8201-2] (Icu/Ics) *1	500V AC	10/3	18/9	22/11	22/11	
	440V AC	15/4	25/13	35/18	35/18	
	415V AC	18/5	25/13	35/18	35/18	
	400V AC	18/5	25/13	35/18	35/18	
	380V AC	18/5	25/13	35/18	35/18	
	230V AC	35/18	35/18	50/25	50/25	
	250V DC	10/5	20/10	20/10	20/10	
Rated operating voltage [UL508] (V AC)	–		–		–	
Dimensions (mm)	a	105	105	140	140	210
	b	165	165	257	257	275
	c	60	60	103	103	103
	d	84	84	146	146	146
<i>Page 06/65</i>						
Mass (kg) Front mounting type	1.1	1.3	4.5	5	9	
Tripping device	Thermal-magnetic		Thermal-magnetic		Thermal-magnetic	
Front mounting, front connection	No-mark	●	●	●	●	●
Front mounting, rear connection	X	●	●	●	●	●
Flush mounting, rear connection	E	●	●	●	●	●
Flush mounting, top & bottom connection	Y	–	–	–	–	–
Plug-in mounting	P	●	●	●	●	●
IEC 35mm wide rail mounting	–	–	–	–	–	
Internal accessories	<i>Page 06/88</i>					
Alarm switch	K	BZ6K□40C	BZ6K□40C	BZ-K70B	BZ-K70B	BZ-K70B
Alarm switch with terminal block	KA	BZ6K□40CA	BZ6K□40CA	BZ-K70BA	BZ-K70BA	BZ-K70BA
Auxiliary switch	W	BZ6W□40C	BZ6W□40C	BZ-W70B	BZ-W70B	BZ-W70B
Auxiliary switch with terminal block	WA	BZ6W□40CA	BZ6W□40CA	BZ-W70BA	BZ-W70BA	BZ-W70BA
Undervoltage trip	R	▲	▲	BZ-R70B-□	BZ-R70B-□	BZ-R70B-□
Shunt trip	F	BZ6F□40C	BZ6F□40C	BZ-F70B-□	BZ-F70B-□	BZ-F70B-□
Shunt trip with terminal block	FA	BZ6F□40CA	BZ6F□40CA	BZ-F70BA-□	BZ-F70BA-□	BZ-F70BA-□
External accessories						
Motor operating mechanism	M	▲	▲	▲	▲	▲
Handle padlocking device Cap type	Q1	–	–	▲	▲	▲
Plate type	Q2	–	–	▲	▲	▲
Mechanical interlocking device	M1	BZ6M140C	BZ6M140C	BZ-M160C	BZ-M160C	BZ-M170C
	M2	BZ-M240C	BZ-M240C	BZ-M260C	BZ-M260C	BZ-M270C
	M3	BZ-M340C	BZ-M340C	BZ-M360C	BZ-M360C	BZ-M370C
Operating handle N-type	N	BZ-N40C	BZ-N40C	BZ-N60C	BZ-N60C	BZ-N70C
Operating handle V-type	V	BZ6V40C	BZ6V40C	BZ6V60C	BZ6V60C	BZ6V70C
Steel enclosure Direct operating	C	BZ-C40B	BZ-C40B	BZ-C60B	BZ-C60B	BZ-C70B
Dustproof steel enclosure Handle operating	CV	BZ-CV40C	BZ-CV40C	BZ-CV60C	BZ-CV60C	BZ-CV70C
Rainproof steel enclosure Handle operating	CW	BZ-CW40C	BZ-CW40C	BZ-CW60C	BZ-CW60C	–
Terminal cover Short	TS	BZ-TS40B	BZ-TS40B	–	–	–
Terminal cover Long	TB	BZ-TB40B	BZ-TB40B	BZ-TB60B	BZ-TB60B	BZ-TB70B
Insulation barrier Interphase *2	B	BZ-B40B	BZ-B40B	B-43A	B-43A	B-43A
Insulation barrier Earth	BL	BZ-BL40B	BZ-BL40B	–	–	–
Handle locking cover	L	BZ6L40C	BZ6L40C	BZ-L70B	BZ-L70B	BZ-L70B
Flat terminal	S	BZ-S50B-2252	BZ-S50B-2253	–	–	–

Notes: *1 Icu: Rated ultimate short-circuit breaking capacity

Ics: Rated service short-circuit breaking capacity

*2 Interphase insulation barriers are standard provided for the front mounting type breakers.

● Available – Not available ▲ Factory-mounted accessory

■ E series/3-pole IEC and CE marking conformed types

Frame	800A	
Pole	3	
Type	Page 06/42	EA803C□-CE
Rated current (A)	700, 800	
Rated insulation voltage (V AC)	690	
[IEC 60947-2, JIS C8201-2] (V DC)	250	
Rated breaking capacity (kA)	600V AC	—
[IEC 60947-2, JIS C 8201-2] (Icu/Ics) *1	500V AC	22/11
	440V AC	35/18
	415V AC	35/18
	400V AC	35/18
	380V AC	35/18
	230V AC	50/25
	250V DC	20/10
Rated operating voltage [UL508] (V AC)	—	
Dimensions (mm)	a	210
	b	275
	c	103
	d	146
Page 06/66		
Mass (kg) Front mounting type	10	
Tripping device	Thermal-magnetic	
Front mounting, front connection	No-mark	●
Front mounting, rear connection	X	●
Flush mounting, rear connection	E	●
Flush mounting, top & bottom connection	Y	—
Plug-in mounting	P	●
IEC 35mm wide rail mounting	—	—
Internal accessories	Page 06/88	
Alarm switch	K	BZ-K70B
Alarm switch with terminal block	KA	BZ-K70BA
Auxiliary switch	W	BZ-W70B
Auxiliary switch with terminal block	WA	BZ-W70BA
Undervoltage trip	R	BZ-R70B-□
Shunt trip	F	BZ-F70B-□
Shunt trip with terminal block	FA	BZ-F70BA-□
External accessories		
Motor operating mechanism	M	▲
Handle padlocking device Cap type	Q1	▲
Plate type	Q2	▲
Mechanical interlocking device	M1	BZ-M170C
	M2	BZ-M270C
	M3	BZ-M370C
Operating handle N-type	N	BZ-N70C
Operating handle V-type	V	BZ6V70C
Steel enclosure Direct operating	C	BZ-C70B
Dustproof steel enclosure Handle operating	CV	BZ-CV70C
Rainproof steel enclosure Handle operating	CW	—
Terminal cover Short	TS	—
Terminal cover Long	TB	BZ-TB70B
Insulation barrier Interphase *2	B	B-43A
Insulation barrier Earth	BL	—
Handle locking cover	L	BZ-L70B
Flat terminal	S	—

Notes: *1 Icu: Rated ultimate short-circuit breaking capacity
Ics: Rated service short-circuit breaking capacity
*2 Interphase insulation barriers are standard provided for the front mounting type breakers.

■ E series/4-pole

Frame	100A	
Pole	4	
Type	Page 06/47	EA104B
Rated current (Amps)	50, 60, 75, 100	
Ambient temp.:	40°C for general use	
Rated insulation voltage Ui (Volts)	AC	660
	DC	—
Rated breaking capacity (kA)	JIS C8370 sym	550V AC 7.5 460V AC 10 220V AC 25 250V DC —
Dimensions (mm)		a 100 b 130 c 60 d 80
Page 06/66		
Mass (kg)	Front mounting type	1.0
Tripping device	Hydraulic-magnetic	
Trip button	Provided	
Front mounting, front connection	No-mark	●
rear connection	X	●
Flush mounting, rear connection	E	●
top & bottom connection	Y	●
Plug-in mounting	P	—
Draw-out	D	—
Internal accessories	Page 06/88	
Alarm switch	K	BZ-K25B□
Auxiliary switch	W	BZ-W25B□
Undervoltage trip	R	—
Shunt trip	F	BZ-F25BT
External accessories		
Motor operating mechanism	M	—
Padlocking device	Q	▲
Mechanical interlocking device	M1	BZ-M120C-4
Operating handle N type	N	BZ-N20C
Operating handle V type	V	BZ-V20C
Steel enclosure	C	—
Steel enclosure with V type handle	CV	—
Terminal cover Short	TS	BZ-TS20B-4
Terminal cover Long	TB	BZ-TB20B-4
Insulation barrier Interphase	B	—
Insulation barrier Earth	BL	—

● Available — Not available ▲ Factory-mounted accessory

Molded Case Circuit Breakers

Quick reference guide

Line protection

■ L series/3-pole

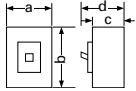
Frame				50A
Pole				3
Type	Page 06/43			LA53B
Rated current (Amps)				5, 10
Ambient temp.:	40°C for general use 45°C for marine use			
Rated insulation voltage Ui (Volts)	AC	660		
	DC	—		
Rated breaking capacity (kA)	JIS C8370	sym	550V AC 480V AC 220V AC 250V DC	42 50 100 —
	IEC 60947-2	[Icu/Ics]	690V AC 660V AC 600V AC 500V AC 440V AC 400V AC 230V AC 250V DC	— — — 42/21 50/25 60/30 100/50 —
	NK	sym	500V AC 250V AC 250V DC	50 100 —
Dimensions (mm)			a	75
			b	150
			c	82
			d	102
Mass (kg)	Front mounting type			1.1
Tripping device				Hydraulic-magnetic
Trip button				Provided
Front mounting, front connection	No-mark	●		●
rear connection	X	—		●
Flush mounting, rear connection	E	—		●
top & bottom connection	Y	—		—
Plug-in mounting	P	—		●
Draw-out	D	—		—
Internal accessories	Page 06/88			
Alarm switch	K	BZ-K23B□		BZ-K35B□
Auxiliary switch	W	BZ-W23B□		BZ-W35B□
Undervoltage trip	R	BZ-R23BT		BZ-R35BT
Shunt trip	F	BZ-F23BT		BZ-F35BT
External accessories				
Motor operating mechanism	M	▲		▲
Padlocking device	Q	▲		▲
Mechanical interlocking device	M1	BZ-M120C-3		BZ-M130C-3
Operating handle N type	N	BZ-N20C		BZ-N30C
Operating handle V type	V	BZ-V20C		BZ-V30C
Steel enclosure	C	—		BZ-C30B-3
Steel enclosure with V type handle	CV	—		BZ-CV30C
Terminal cover Short	TS	—		BZ-TS30B-3
Terminal cover Long	TB	—		BZ-TB30B-3
Insulation barrier Interphase	B	BZ-B30B (Line), B35B (Load)		BZ-B30B
Insulation barrier Earth	BL	BZ-BL20B-3		BZ-BL35B

■ H series/2, 3-pole

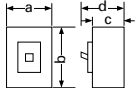
Frame	50A		100A		
Pole	2	3	2	3	3
Type	H52BA	H53BA	H102BA	H103BA	H103R
Rated current (Amps)	15, 20, 30 40, 50		15, 20, 30, 40 50, 60, 75, 100		40, 50, 60 75, 100
Rated insulation voltage Ui (Volts)	690	250	690	250	660 250
Rated breaking capacity (kA)	35 65 125 40		35 65 125 40		42 85 125 40
	— — 25/7 35/9 65/17 65/17 125/32 40/10		— — 25/7 35/9 65/17 65/17 125/32 40/10		— — — — — — — —
	65 100 —		65 100 —		85 125 —
Dimensions (mm)			a	90	105
			b	155	165
			c	60	99
			d	82	127
Mass (kg)	1.1	1.2	1.1	1.2	2.3
Tripping device	Thermal-magnetic		Thermal-magnetic		Thermal-magnetic
Trip button	Provided		Provided		Provided
Front mounting, front connection	●		●		●
rear connection	●		●		●
Flush mounting, rear connection	●		●		●
top & bottom connection	—		—		—
Plug-in mounting	●		●		●
Draw-out	—		—		—
Internal accessories	Page 06/88				
Alarm switch	K	BZ-K35B□		BZ-K35B□	BZ-K50B□
Auxiliary switch	W	BZ-W35B□		BZ-W35B□	BZ-W50B□
Undervoltage trip	R	BZ-R35BT		BZ-R35BT	BZ-R50BT
Shunt trip	F	BZ-F35BT		BZ-F35BT	BZ-F50BT
External accessories					
Motor operating mechanism	M	▲		▲	▲
Padlocking device	Q	▲		▲	▲
Mechanical interlocking device	M1	BZ-M130C-3		BZ-M130C-3	BZ-M140C
Operating handle N type	N	BZ-N30C		BZ-N30C	BZ-N50C
Operating handle V type	V	BZ-V30C		BZ-V30C	BZ-V50C
Steel enclosure	C	—		BZ-C30B-3	BZ-C50B
Steel enclosure with V type handle	CV	—		BZ-CV30C	—
Terminal cover Short	TS	—		BZ-TS30B-3	BZ-TS50B
Terminal cover Long	TB	—		BZ-TB30B-3	BZ-TB50B
Insulation barrier Interphase	B	BZ-B30B (Line), B35B (Load)		BZ-B30B	BZ-B50B
Insulation barrier Earth	BL	BZ-BL35B		BZ-BL35B	BZ-BL50B

● Available — Not available ▲ Factory-mounted accessory

Notes: • The breaking capacity for the 240V, 380V and 415V circuits are equivalent to that of 230V, 400V and 440V, respectively.
• Interphase insulation barriers are standard provided for the front mounting type breakers.

Molded Case Circuit Breakers

Quick reference guide

Line protection

■ H series/2, 3-pole

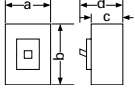
Frame		225A			400A		
Pole		2	3	3	2	3	3
Type		<i>Page 06/43</i>					
		H202BA	H203BA	H203R	H402B	H403B	H403R
Rated current (Amps)		125, 150, 175			125, 150, 175		
Ambient temp.: 40°C for general use 45°C for marine use		200, 225			200, 225		
Rated insulation voltage Ui (Volts)		AC DC			AC DC		
		690 250			660 250		
Rated breaking capacity (kA)	JIS C8370 sym	550V AC	35	42	42	85	85
		480V AC	65	85	65	125	125
		220V AC	125	125	125	125	125
		250V DC	40	40	40	40	40
Rated breaking capacity [Icu/Ics]	IEC 60947-2	690V AC	—	—	—	—	—
		660V AC	—	—	—	—	—
		600V AC	25/7	—	35/18	—	—
		500V AC	35/9	—	42/21	85/43	85/43
		440V AC	65/17	—	65/33	125/63	125/63
		400V AC	65/17	—	65/33	125/63	125/63
		230V AC	125/32	—	125/63	125/63	125/63
		250V DC	40/10	—	40/20	40/20	40/20
Dimensions (mm)	NK sym	500V AC	65	85	50	—	—
		250V AC	100	125	125	—	—
		250V DC	—	—	—	—	—
<i>Page 06/70</i>		a	105	105	140	140	
		b	165	165	257	257	
		c	60	99	103	103	
		d	84	127	146	146	
Mass (kg)	Front mounting type	1.1	1.3	2.3	4.5	5	5
Tripping device		Thermal-magnetic			Thermal-magnetic		
Trip button		Provided			Provided		
Front mounting, front connection	No-mark	●	●	●	●	●	
	rear connection	X	●	●	●	●	
Flush mounting, rear connection	E	●	●	●	●	●	
	top & bottom connection	Y	—	—	—	—	
Plug-in mounting	P	●	●	●	●	●	
Draw-out	D	—	—	—	—	—	
Internal accessories <i>Page 06/88</i>							
Alarm switch	K	BZ-K40B□	BZ-K40B□	BZ-K40B□	BZ-K70B□	BZ-K70B□	
Auxiliary switch	W	BZ-W40B□	BZ-W40B□	BZ-W40B□	BZ-W70B□	BZ-W70B□	
Undervoltage trip	R	BZ-R40BT	BZ-R40BT	BZ-R40BT	BZ-R70BT	BZ-R70BT	
Shunt trip	F	BZ-F40BT	BZ-F40BT	BZ-F40BT	BZ-F70BT	BZ-F70BT	
External accessories							
Motor operating mechanism	M	▲	▲	▲	▲	▲	
Padlocking device	Q	▲	▲	▲	▲	▲	
Mechanical interlocking device	M1	BZ-M140C	BZ-M140C	BZ-M140C	BZ-M160C	BZ-M160C	
Operating handle N type	N	BZ-N40C	BZ-N50C	BZ-N50C	BZ-N60C	BZ-N60C	
Operating handle V type	V	BZ-V40C	BZ-V50C	BZ-V50C	BZ-V60C	BZ-V60C	
Steel enclosure	C	BZ-C40B	BZ-C50B	BZ-C50B	BZ-C60B	BZ-C60B	
Steel enclosure with V type handle	CV	—	—	—	BZ-CV60C	BZ-CV60C	
Terminal cover Short	TS	BZ-TS40B	BZ-TS50B	BZ-TS50B	—	—	
Terminal cover Long	TB	BZ-TB40B	BZ-TB50B	BZ-TB50B	BZ-TB60B	BZ-TB60B	
Insulation barrier Interphase	B	BZ-B40B	BZ-B50B	BZ-B50B	B-43A	B-43A	
Insulation barrier Earth	BL	BZ-BL40B	BZ-BL50B	BZ-BL50B	—	—	

● Available — Not available ▲ Factory-mounted accessory

Notes: • The breaking capacity for the 240V, 380V and 415V circuits are equivalent to that of 230V, 400V and 440V, respectively.
• Interphase insulation barriers are standard provided for the front mounting type breakers.

Molded Case Circuit Breakers

Quick reference guide

Line protection

■ H series/3-pole

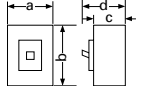
Frame		600A		800A		
Pole		3		3		
Type		Page 06/42 H603B		H603R		
Rated current (Amps)		500, 600		500, 600		
Ambient temp.:		40°C for general use 45°C for marine use		700, 800		
Rated insulation voltage Ui (Volts)		AC DC		690 250		
Rated breaking capacity (kA)	JIS C8370 sym	550V AC 480V AC 220V AC 250V DC	42 65 125 40	85 125 125 40	42 65 125 40	85 125 125 40
	IEC 60947-2 [Icu/Ics]	690V AC 660V AC 600V AC 500V AC 415V AC 380V AC 240V AC 250V DC	— — 35/18 42/21 65/33 65/33 125/63 40/20	— — — 85/43 125/63 125/63 125/63 40/20	— — 35/18 42/21 65/33 65/33 125/63 40/20	— — — 85/43 125/63 125/63 125/63 40/20
	NK sym	500V AC 250V AC 250V DC	50 125 —	— — —	50 125 —	— — —
Dimensions (mm)		a b c d	210 275 103 146	210 275 103 146	210 275 103 146	210 275 103 146
Page 06/71						
Mass (kg) Front mounting type		9		9		
Tripping device		Thermal-magnetic		Thermal-magnetic		
Trip button		Provided		Provided		
Front mounting, front connection	No-mark	●	●	●	●	
rear connection	X	●	●	●	●	
Flush mounting, rear connection	E	●	●	●	●	
top & bottom connection	Y	—	—	—	—	
Plug-in mounting	P	●	●	●	●	
Draw-out	D	●	●	●	●	
Internal accessories Page 06/88						
Alarm switch	K	BZ-K70B□	BZ-K70B□	BZ-K70B□	BZ-K70B□	
Auxiliary switch	W	BZ-W70B□	BZ-W70B□	BZ-W70B□	BZ-W70B□	
Undervoltage trip	R	BZ-R70BT	BZ-R70BT	BZ-R70BT	BZ-R70BT	
Shunt trip	F	BZ-F70BT	BZ-F70BT	BZ-F70BT	BZ-F70BT	
External accessories						
Motor operating mechanism	M	▲	▲	▲	▲	
Padlocking device	Q	▲	▲	▲	▲	
Mechanical interlocking device	M1	BZ-M170C	BZ-M170C	BZ-M170C	BZ-M170C	
Operating handle N type	N	BZ-N70C	BZ-N70C	BZ-N70C	BZ-N70C	
Operating handle V type	V	BZ-V70C	BZ-V70C	BZ-V70C	BZ-V70C	
Steel enclosure	C	BZ-70B	BZ-70B	BZ-70B	BZ-70B	
Steel enclosure with V type handle	CV	BZ-CV70C	BZ-CV70C	BZ-CV70C	BZ-CV70C	
Terminal cover Short	TS	—	—	—	—	
Terminal cover Long	TB	BZ-TB70B	BZ-TB70B	BZ-TB70B	BZ-TB70B	
Insulation barrier Interphase	B	B-43A	B-43A	B-43A	B-43A	
Insulation barrier Earth	BL	—	—	—	—	

Notes: ● Interphase insulation barriers are standard provided for the front mounting type breakers. ● Available — Not available ▲ Factory-mounted accessory

Molded Case Circuit Breakers

Quick reference guide

Motor protection

Motor protection breakers

Motors are normally controlled by MCCBs and magnetic starters. In this case the MCCB carries out overcurrent or short-circuit current protection while the starter deals with ON-OFF switching

of the motor and offers protection against sustained overload currents. These are the motor breakers which combine the two functions. FUJI motor breakers are designed to eliminate erroneous operations due to

the rush current produced at the time of starting the motor. They will trip in the face of sustained overcurrent when the integrated bimetal relay has operated.

■ S series/2, 3-pole IEC and CE marking conformed types

Frame	30A		50A		60A	
Pole	2		3	3	3	
Type	SA32CM□-CE		SA33CM□-CE	SA53CM□-CE	SA53RCM□-CE	SA63CM□-CE
Rated current (A) *1 Ambient temp.: 40°C for general use	2, 4, 5, 8, 10, 16		0.7, 1.4, 2, 2.6, 4 5, 8, 10, 12, 16, 24, 32	0.7, 1.4, 2, 2.6, 4 5, 8, 10, 12, 16, 24, 32, 40, 45	10, 12, 16, 24, 32, 40, 45	60
Rated insulation voltage (V AC) [IEC 60947-2, JIS C8201-2] (V DC)	690		690	690	690	690
Rated breaking capacity (kA) [IEC 60947-2, JIS C8201-2] (Icu/Ics) *2	500V AC 440V AC 415V AC 400V AC 380V AC 230V AC	1.5/1 2.5/2 2.5/2 2.5/2 2.5/2 5/3	7.5/4 7.5/4 7.5/4 7.5/4 7.5/4 10/5	7.5/4 7.5/4 7.5/4 7.5/4 7.5/4 10/5	7.5/4 10/5 10/5 10/5 10/5 25/13	5/3 7.5/4 7.5/4 7.5/4 7.5/4 10/5
Rated operating voltage [UL508] (V AC)	550		600	600	600	600
Dimensions (mm)	a b c d	50 100 60 84	75 100 60 84	75 100 60 84	75 100 60 84	75 100 60 84
Mass (kg) Front mounting type	0.5		0.5	0.5	0.5	0.6
Tripping device	Hydraulic-magnetic		Hydraulic-magnetic	Hydraulic-magnetic	Hydraulic-magnetic	Hydraulic-magnetic
Front mounting, front connection	No-mark	●	●	●	●	●
Front mounting, rear connection	X	●	●	●	●	●
Flush mounting, rear connection	E	●	●	●	●	●
Flush mounting, top & bottom connection	Y	●	●	●	●	●
Plug-in mounting	P	●	●	●	●	●
IEC 35mm wide rail mounting		●	●	●	●	●
Internal accessories						
Alarm switch	K	BZ6KR10C	BZ6K□10C	BZ6K□10C	BZ6K□10C	BZ6K□10C
Auxiliary switch	W	BZ6WR10C	BZ6W□10C	BZ6W□10C	BZ6W□10C	BZ6W□10C
Undervoltage trip	R	BZ6RR10C	BZ6R□10C	BZ6R□10C	BZ6R□10C	BZ6R□10C
Shunt trip	F	BZ6FR10C	BZ6F□10C	BZ6F□10C	BZ6F□10C	BZ6F□10C
External accessories						
Handle padlocking device	Cap type	Q1	—	—	—	—
	Plate type	Q2	▲	▲	▲	▲
Mechanical interlocking device	M1	BZ6M110C2	BZ6M110C3	BZ6M110C3	BZ6M110C3	BZ6M110C3
	M2	BZ6M210C2	BZ6M210C3	BZ6M210C3	BZ6M210C3	BZ6M210C3
	M3	BZ6M310C2	BZ6M310C3	BZ6M310C3	BZ6M310C3	BZ6M310C3
Operating handle	N-type	N	BZ6N10C	BZ6N10C	BZ6N10C	BZ6N10C
	V-type	V	BZ6V10C	BZ6V10C	BZ6V10C	BZ6V10C
Steel enclosure	Direct operating	C	BZ6C10C2	BZ6C10C3	BZ6C10C3	BZ6C10C3
Dustproof steel enclosure	Handle operating	CV	BZ6CV10C	BZ6CV10C	BZ6CV10C	BZ6CV10C
Rainproof steel enclosure	Handle operating	CW	BZ6CW10C	BZ6CW10C	BZ6CW10C	BZ6CW10C
Terminal cover	Short	TS	BZ6TS10C2	BZ6TS10C3	BZ6TS10C3	BZ6TS10C3
	Long	TB	BZ6TB10C2	BZ6TB10C3	BZ6TB10C3	BZ6TB10C3
Insulation barrier	Interphase *3	B	BZ6B10C	BZ6B10C	BZ6B10C	BZ6B10C
	Earth	BL	BZ6BL10C2	BZ6BL10C3	BZ6BL10C3	BZ6BL10C3
Handle locking cover		L	BZ6L10C	BZ6L10C	BZ6L10C	BZ6L10C
Flat terminal		S	BZ6S10C502	BZ6S10C503	BZ6S10C503	BZ6S10C1003

Notes: *1 For further information related to motor capacity, see page 06/49.

*2 Icu: Rated ultimate short-circuit breaking capacity

Ics: Rated service short-circuit breaking capacity

*3 Interphase insulation barriers are standard provided for the front mounting type breakers of 50AF and over.

● Available – Not available ▲ Factory-mounted accessory

Molded Case Circuit Breakers

Quick reference guide

Motor protection

■ S series/2, 3-pole IEC and CE marking conformed types

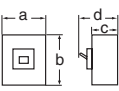
Frame		100A		225A	
Pole		3		3	
Type	Page 06/42	SA103CM□-CE	SA103RCM□-CE	SA203CM□-CE	SA203RCM□-CE
Rated current (A) *1		16, 24, 32, 40, 45,	16, 24, 32, 40, 45,	125, 150, 175, 200,	125, 150, 175, 200,
Ambient temp.: 40°C for general use		60, 75, 90	60, 75, 90	225	225
Rated insulation voltage (V AC)		690	690	690	690
[IEC 60947-2, JIS C8201-2] (V DC)		–	–	–	–
Rated breaking capacity (kA)	500V AC	15/4	30/8	15/4	30/8
[IEC 60947-2, JIS C8201-2]	440V AC	25/7	50/13	25/7	50/13
(Icu/Ics) *2	415V AC	30/8	50/13	30/8	50/13
	400V AC	30/8	50/13	30/8	50/13
	380V AC	30/8	50/13	30/8	50/13
	230V AC	50/25	100/50	50/25	100/50
Rated operating voltage [UL508] (V AC)		–	–	–	–
Dimensions (mm)		a 90	90	105	105
		b 155	155	165	165
		c 60	60	60	60
		d 82	82	84	84
Page 06/53					
Mass (kg) Front mounting type		1.1	1.4	1.3	1.3
Tripping device		Thermal-magnetic	Thermal-magnetic	Thermal-magnetic	Thermal-magnetic
Front mounting, front connection	No-mark	●	●	●	●
Front mounting, rear connection	X	●	●	●	●
Flush mounting, rear connection	E	●	●	●	●
Flush mounting, top & bottom connection	Y	–	–	–	–
Plug-in mounting	P	●	●	●	●
IEC 35mm wide rail mounting		–	–	–	–
Internal accessories	Page 06/88				
Alarm switch	K	BZ6K□30C	BZ6K□30C	BZ6K□40C	BZ6K□40C
Auxiliary switch	W	BZ6W□30C	BZ6W□30C	BZ6W□40C	BZ6W□40C
Undervoltage trip	R	▲	▲	▲	▲
Shunt trip	F	BZ6F□30C	BZ6F□30C	BZ6F□40C	BZ6F□40C
External accessories					
Handle padlocking device	Cap type	Q1 –	–	–	–
	Plate type	Q2 ▲	▲	▲	▲
Mechanical interlocking device	M1	BZ6M130C-3	BZ6M130C-3	BZ6M140C	BZ6M140C
	M2	BZ-M230C-3	BZ-M230C-3	BZ-M240C	BZ-M240C
	M3	BZ-M330C-3	BZ-M330C-3	BZ-M340C	BZ-M340C
Operating handle	N-type	N BZ-N30C	BZ-N30C	BZ-N40C	BZ-N40C
	V-type	V BZ6V30C	BZ6V30C	BZ6V40C	BZ6V40C
Steel enclosure	Direct operating	C BZ6C30C3	BZ6C30C3	BZ-C40B	BZ-C40B
Dustproof steel enclosure	Handle operating	CV BZ-CV30C	BZ-CV30C	BZ-CV40C	BZ-CV40C
Rainproof steel enclosure	Handle operating	CW BZ-CW30C	BZ-CW30C	BZ-CW40C	BZ-CW40C
Terminal cover	Short	TS BZ-TS30B-3	BZ-TS30B-3	BZ-TS40B	BZ-TS40B
	Long	TB BZ-TB30B-3	BZ-TB30B-3	BZ-TB40B	BZ-TB40B
Insulation barrier	Interphase *3	B BZ-B30B	BZ-B30B	BZ-B40B	BZ-B40B
	Earth	BL BZ-BL35B	BZ-BL35B	BZ-BL40B	BZ-BL40B
Handle locking cover		L BZ6L30C	BZ6L30C	BZ6L40C	BZ6L40C
Flat terminal		S BZ-S35B-1003	BZ-S35B-1003	BZ-S50B-2253	BZ-S50B-2253

Notes: *1 For further information related to motor capacity, [see page 06/49](#).

● Available – Not available ▲ Factory-mounted accessory

*2 Icu: Rated ultimate short-circuit breaking capacity

Ics: Rated service short-circuit breaking capacity

*3 Interphase insulation barriers are standard provided for the front mounting type breakers.

■ E series/3-pole IEC and CE marking conformed types

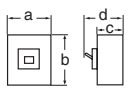
Frame		30A	50A	60A	100A	225A
Pole		3	3	3	3	3
Type	Page 06/42	EA33ACM□-CE	EA53CM□-CE	EA63CM□-CE	EA103CM□-CE	EA203CM□-CE
Rated current (A) *1 Ambient temp.: 40°C for general use		1.4, 2.6, 4, 8, 10, 16, 24, 32	24, 32, 40, 45	60	60, 75, 90	125, 150, 175, 200, 225
Rated insulation voltage (V AC) [IEC 60947-2, JIS C8201-2] (V DC)		500 –	690 –	690 –	690 –	690 –
Rated breaking capacity (kA) [IEC 60947-2, JIS C8201-2] (Icu/Ics) *2		– 1.5/1 1.5/1 1.5/1 1.5/1 2.5/2	1.5/1 2.5/2 2.5/2 2.5/2 2.5/2 5/3	1.5/1 2.5/2 2.5/2 2.5/2 5/3 5/3	7.5/4 10/5 10/5 10/5 10/5 25/13	10/3 15/4 18/5 18/5 18/5 35/18
Rated operating voltage [UL508] (V AC)		240	240	550	–	–
Dimensions (mm)		a: 75 b: 100 c: 60 d: 84	a: 75 b: 100 c: 60 d: 84	a: 75 b: 100 c: 60 d: 84	a: 75 b: 100 c: 60 d: 84	a: 105 b: 165 c: 60 d: 84
Mass (kg) Front mounting type		0.5	0.5	0.6	0.6	1.3
Tripping device		Hydraulic-magnetic	Hydraulic-magnetic	Hydraulic-magnetic	Hydraulic-magnetic	Thermal-magnetic
Front mounting, front connection	No-mark	●	●	●	●	●
Front mounting, rear connection	X	●	●	●	●	●
Flush mounting, rear connection	E	●	●	●	●	●
Flush mounting, top & bottom connection	Y	●	●	●	●	–
Plug-in mounting	P	●	●	●	●	●
IEC 35mm wide rail mounting		●	●	●	●	–
Internal accessories	Page 06/88					
Alarm switch	K	BZ6K□10C	BZ6K□10C	BZ6K□10C	BZ6K□10C	BZ6K□40C
Auxiliary switch	W	BZ6W□10C	BZ6W□10C	BZ6W□10C	BZ6W□10C	BZ6W□40C
Undervoltage trip	R	BZ6R□10C	BZ6R□10C	BZ6R□10C	BZ6R□10C	–
Shunt trip	F	BZ6F□10C	BZ6F□10C	BZ6F□10C	BZ6F□10C	BZ6F□40C
External accessories						
Handle padlocking device	Cap type Q1	▲	▲	▲	▲	▲
	Plate type Q2	▲	▲	▲	▲	▲
Mechanical interlocking device	M1	BZ6M110C3	BZ6M110C3	BZ6M110C3	BZ6M110C3	BZ6M140C
	M2	BZ6M210C3	BZ6M210C3	BZ6M210C3	BZ6M210C3	BZ-M240C
	M3	BZ6M310C3	BZ6M310C3	BZ6M310C3	BZ6M310C3	BZ-M340C
Operating handle	N-type N	BZ6N10C	BZ6N10C	BZ6N10C	BZ6N10C	BZ-N40C
	V-type V	BZ6V10C	BZ6V10C	BZ6V10C	BZ6V10C	BZ6V40C
Steel enclosure	Direct operating C	BZ6C10C3	BZ6C10C3	BZ6C10C3	BZ6C25C3	BZ-C40B
Dustproof steel enclosure	Handle operating CV	BZ6CV10C	BZ6CV10C	BZ6CV10C	BZ6CV25C	BZ-CV40C
Rainproof steel enclosure	Handle operating CW	BZ6CW10C	BZ6CW10C	BZ6CW10C	BZ6CW25C	BZ-CW40C
Terminal cover	Short TS	BZ6TS10C3	BZ6TS10C3	BZ6TS10C3	BZ6TS10C3	BZ-TS40B
	Long TB	BZ6TB10C3	BZ6TB10C3	BZ6TB10C3	BZ6TB10C3	BZ-TB40B
Insulation barrier	Interphase *3 B	BZ6B10C	BZ6B10C	BZ6B10C	BZ6B10C	BZ-B40B
	Earth BL	BZ6BL10C3	BZ6BL10C3	BZ6BL10C3	BZ6BL10C3	BZ-BL40B
Handle locking cover	L	BZ6L10C	BZ6L10C	BZ6L10C	BZ6L10C	BZ6L40C
Flat terminal	S	BZ6S10C503	BZ6S10C503	BZ6S10C1003	BZ6S10C1003	BZ-S50B-2253

Notes: *1 For further information related to motor capacity, [see page 06/50](#).

● Available – Not available ▲ Factory-mounted accessory

*2 Icu: Rated ultimate short-circuit breaking capacity

Ics: Rated service short-circuit breaking capacity

*3 Interphase insulation barriers are standard provided for the front mounting type breakers of 50AF and over.

Molded Case Circuit Breakers

Quick reference guide

Motor protection

■ L and H series/3-pole

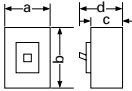
Frame	50A		
Pole	3		3
Type	Page 06/43	LA53BM	H53BAM
Rated current (Amps) *1 Ambient temp.: 40°C for general use 45°C for marine use		5, 8, 10, 12	16, 24, 32, 40, 45
Rated insulation voltage Ui (Volts)	AC DC	660 —	660 —
Rated breaking capacity (kA)	JIS C8370 sym	550V AC 480V AC 220V AC	42 50 100
	IEC60947-2 [Icu/Ics]	600V AC 500V AC 440V AC 400V AC 230V AC	— 42/21 50/25 60/30 100/50
	NK sym	500V AC 250V AC	50 100
Dimensions (mm) Page 06/70		a	75
		b	150
		c	82
		d	102
Mass (kg)	Front mounting type	1.1	1.4
Tripping device		Hydraulic-magnetic	Thermal-magnetic
Trip button		Provided	
Front mounting, front connection	No-mark	●	●
rear connection	X	—	●
Flush mounting, rear connection	E	—	●
top & bottom connection	Y	—	—
Plug-in mounting	P	—	●
Draw-out	D	—	—
Internal accessories	Page 06/88		
Alarm switch	K	BZ-K23B□	BZ-K35B□
Auxiliary switch	W	BZ-W23B□	BZ-W35B□
Undervoltage trip	R	BZ-R23BT□	BZ-R35BT□
Shunt trip	F	BZ-F23BT□	BZ-F35BT□
External accessories			
Motor operating mechanism	M	▲	▲
Padlocking device	Q	▲	▲
Mechanical interlocking device	M1	BZ-M120C-3	BZ-M130C-3
Operating handle N type	N	BZ-N20C	BZ-N30C
Operating handle V type	V	BZ-V20C	BZ-V30C
Steel enclosure	C	—	BZ-C30B-3
Steel enclosure with V type handle	CV	—	BZ-CV30C
Terminal cover Short	TS	—	BZ-TS30B-3
Terminal cover Long	TB	—	BZ-TB30B-3
Insulation barrier Interphase	B	BZ-B30B (LINE), B35B (LOAD)	BZ-B30B
Insulation barrier Earth	BL	BZ-BL20B-3	BZ-BL35B

Notes: *1 For further information related to motor capacity, see page 06/50.

● Available — Not available ▲ Factory-mounted accessory

■ S series/2, 3-pole UL489 Listed

Frame		50A		100A			
Pole		2	3	2	3	2	3
Type		SA52RCUL	SA53RCUL	SA102CUL	SA103CUL	SA102RCUL	SA103RCUL
Rated current (A)		3, 5, 10, 15, 20, 30, 40, 50		15, 20, 30, 40, 50, 60, 70, 75, 80, 90, 100		15, 20, 30, 40, 50, 60, 70, 75, 80, 90, 100	
Rated insulation voltage [IEC 60947-2] (V AC)		690		690		690	
Rated operating voltage [UL489] (V AC)		240		240		480Y/277	
Rated breaking capacity (kA)	UL489 (cUL)	480Y/277V AC	–	–	–	25	–
		240V AC	14	35	–	85	–
	IEC 60947-2	600V AC	5/3	–	–	–	–
	(Icu/Ics) *1	500V AC	7.5/4	15/4	–	30/8	–
	JIS C8201-2	440V AC	10/5	25/7	–	50/13	–
		415V AC	10/5	30/8	–	50/13	–
		400V AC	10/5	30/8	–	50/13	–
		380V AC	10/5	30/8	–	50/13	–
	230V AC	25/13	50/25	15/8	–	100/50	–
	250V DC	–	–	–	–	40/20	–
Dimensions (mm)		a	50	75	90	90	90
		b	120	120	155	155	155
		c	60	60	60	60	60
		d	84	84	82	82	82
Mass (kg) Front mounting type		0.4	0.5	1.1	1.2	1.1	1.2
Tripping device		Hydraulic-magnetic		Thermal-magnetic		Thermal-magnetic	
Connecting terminal	Screw	●	●	●	●	●	●
	Flat	●	●	●	●	●	●
	Block	–	–	●	●	●	●
Internal accessories		Page 06/88					
Alarm switch	K	BZ6KR10CU	BZ6K□10CU	BZ6KR30CU	BZ6K□30CU	BZ6K□30CU	BZ6K□30CU
Alarm switch with terminal block	KA	BZ6KR10CAU	BZ6K□10CAU	BZ6KR30CAU	BZ6K□30CAU	BZ6K□30CAU	BZ6K□30CAU
Auxiliary switch	W	BZ6WR10CU	BZ6W□10CU	BZ6WR30CU	BZ6W□30CU	BZ6W□30CU	BZ6W□30CU
Auxiliary switch with terminal block	WA	BZ6WR10CAU	BZ6W□10CAU	BZ6WR30CAU	BZ6W□30CAU	BZ6W□30CAU	BZ6W□30CAU
Undervoltage trip with terminal block	RA	BZ6R□10CAU	BZ6R□10CAU	▲	▲	▲	▲
Shunt trip	F	BZ6F□10CU	BZ6F□10CU	BZ6F□30CU	BZ6F□30CU	BZ6F□30CU	BZ6F□30CU
Shunt trip with terminal block	FA	BZ6F□10CAU	BZ6F□10CAU	BZ6F□30CAU	BZ6F□30CAU	BZ6F□30CAU	BZ6F□30CAU
External accessories							
Handle padlocking device	Cap type	Q1	–	–	–	–	–
Operating handle	N-type	N	BZ6N10CP	BZ6N10CP	BZ6N30CP	BZ6N30CP	BZ6N30CP
Operating handle	V-type	V	BZ6V10C	BZ6V10C	BZ6V30C	BZ6V30C	BZ6V30C
Terminal cover	Short	TS	Provided	Provided	BZ-TS30B-3	BZ-TS30B-3	BZ-TS30B-3
Terminal cover	Long	TB	BZ6TB10C2U	BZ6TB10C3U	BZ-TB30B-3	BZ-TB30B-3	BZ-TB30B-3
Terminal cover for flat terminal		TL	–	–	BZ-TL30B-3	BZ-TL30B-3	BZ-TL30B-3
Insulation barrier	Interphase *2	B	–	–	BZ6B30CU	BZ6B30CU	BZ6B30CU
Handle locking cover		L	BZ6L10C	BZ6L10C	BZ6L30C	BZ6L30C	BZ6L30C
Flat terminal		S	BZ-SU20B	BZ-SU20B	BZ6SU35B	BZ6SU35B	BZ6SU35B
Block terminal		TA	–	–	BZ6TA100	BZ6TA100	BZ6TA100

Notes: *1 Icu: Rated ultimate short-circuit breaking capacity
Ics: Rated service short-circuit breaking capacity
*2 Interphase insulation barriers are standard provided for the front mounting type breakers of 100AF and over.

● Available – Not available ▲ Factory-mounted accessory

06

Molded Case Circuit Breakers

Quick reference guide

UL Listed

■ S series/2, 3-pole UL489 Listed

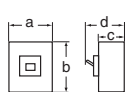
Frame		225A			
Pole		2	3	2	3
Type		<i>Page 06/44</i> SA202CUL		SA203CUL	
Rated current (A)		125, 150, 175, 200, 225		125, 150, 175, 200, 225	
Rated insulation voltage [IEC 60947-2] (V AC)		690		690	
Rated operating voltage [UL489] (V AC)		240		480Y/277	
Rated breaking capacity (kA)	UL489 (cUL)	480Y/277V AC	–	25	
		240V AC	35	85	
	IEC 60947-2	600V AC	–	–	
	(Icu/Ics) *1	500V AC	15/4	30/8	
	JIS C8201-2	440V AC	25/7	50/13	
		415V AC	30/8	50/13	
		400V AC	30/8	50/13	
	380V AC	30/8	50/13		
	230V AC	50/25	100/50		
	250V DC	15/8	40/20		
Dimensions (mm)		a	105	105	105
		b	165	165	165
		c	60	60	60
		d	84	84	84
<i>Page 06/76</i>					
Mass (kg) Front mounting type		1.1	1.3	1.1	1.3
Tripping device		Thermal-magnetic		Thermal-magnetic	
Connecting terminal	Screw	●	●	●	●
	Flat	●	●	●	●
	Block	●	●	●	●
Internal accessories <i>See page 06/88</i>					
Alarm switch	K	BZ6K□40CU	BZ6K□40CU	BZ6K□40CU	BZ6K□40CU
Alarm switch with terminal block	KA	BZ6K□40CAU	BZ6K□40CAU	BZ6K□40CAU	BZ6K□40CAU
Auxiliary switch	W	BZ6W□40CU	BZ6W□40CU	BZ6W□40CU	BZ6W□40CU
Auxiliary switch with terminal block	WA	BZ6W□40CAU	BZ6W□40CAU	BZ6W□40CAU	BZ6W□40CAU
Undervoltage trip with terminal block	RA	▲	▲	▲	▲
Shunt trip	F	BZ6F□40CU	BZ6F□40CU	BZ6F□40CU	BZ6F□40CU
Shunt trip with terminal block	FA	BZ6F□40CAU	BZ6F□40CAU	BZ6F□40CAU	BZ6F□40CAU
External accessories					
Handle padlocking device	Cap type	Q1	–	–	–
Operating handle	N-type	N	BZ6N40CP	BZ6N40CP	BZ6N40CP
Operating handle	V-type	V	BZ6V40C	BZ6V40C	BZ6V40C
Terminal cover	Short	TS	BZ-TS40B	BZ-TS40B	BZ-TS40B
Terminal cover	Long	TB	BZ-TB40B	BZ-TB40B	BZ-TB40B
Terminal cover for flat terminal		TL	BZ-TL40B	BZ-TL40B	BZ-TL40B
Insulation barrier	Interphase *2	B	BZ6B40CU	BZ6B40CU	BZ6B40CU
Handle locking cover		L	BZ6L40C	BZ6L40C	BZ6L40C
Flat terminal		S	BZ6SU50B	BZ6SU50B	BZ6SU50B
Block terminal		TA	BZ6TA225	BZ6TA225	BZ6TA225

Notes: *1 Icu: Rated ultimate short-circuit breaking capacity

Ics: Rated service short-circuit breaking capacity

*2 Interphase insulation barriers are standard provided for the front mounting type breakers.

● Available – Not available ▲ Factory-mounted accessory

■ S series/2, 3-pole UL489 Listed

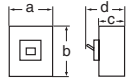
Frame		400A				
Pole		2	3	2	3	
Type	Page 06/44	SA402CUL	SA403CUL	SA402RCUL	SA403RCUL	
Rated current (A)		250, 300, 350, 400		250, 300, 350, 400		
Rated insulation voltage [IEC 60947-2] (V AC)		690		690		
Rated operating voltage [UL489] (V AC)		240		480		
Rated breaking capacity (kA)	UL489 (cUL)	480V	25	50		
		480Y/277V	25	50		
		240V	42	85		
	IEC 60947-2	600V AC	–	30/15		
	(Icu/Ics) *1	500V AC	22/11	35/18		
	JIS C8201-2	440V AC	35/18	50/25		
		415V AC	35/18	50/25		
		400V AC	35/18	50/25		
		380V AC	35/18	50/25		
	230V AC	50/25	85/43			
	250V DC	20/10	40/20			
Dimensions (mm)		a	140	140	140	140
		b	257	257	257	257
		c	103	103	103	103
		d	146	146	146	146
Page 06/76						
Mass (kg) Front mounting type		4.5	5	4.5	5	
Tripping device		Thermal-magnetic		Thermal-magnetic		
Connecting terminal	Screw	–	–	–	–	
	Flat	●	●	●	●	
	Block	●	●	●	●	
Internal accessories Page 06/88						
Alarm switch	K	▲	▲	▲	▲	
Alarm switch with terminal block	KA	▲	▲	▲	▲	
Auxiliary switch	W	▲	▲	▲	▲	
Auxiliary switch with terminal block	WA	▲	▲	▲	▲	
Undervoltage trip with terminal block	RA	▲	▲	▲	▲	
Shunt trip	F	▲	▲	▲	▲	
Shunt trip with terminal block	FA	▲	▲	▲	▲	
External accessories						
Handle padlocking device Cap type	Q1	▲	▲	▲	▲	
Operating handle N-type	N	BZ6N60CP	BZ6N60CP	BZ6N60CP	BZ6N60CP	
Operating handle V-type	V	BZ6V60C	BZ6V60C	BZ6V60C	BZ6V60C	
Terminal cover Short	TS	–	–	–	–	
Terminal cover Long	TB	BZ-TB60B	BZ-TB60B	BZ-TB60B	BZ-TB60B	
Terminal cover for flat terminal	TL	–	–	–	–	
Insulation barrier Interphase *2	B	B-43A	B-43A	B-43A	B-43A	
Handle locking cover	L	BZ-L70B	BZ-L70B	BZ-L70B	BZ-L70B	
Flat terminal	S	BZ-SU60B	BZ-SU60B	BZ-SU60B	BZ-SU60B	
Block terminal	TA	Up to 350A: BZ6TA350 400A: BZ6TA400	Up to 350A: BZ6TA350 400A: BZ6TA400	Up to 350A: BZ6TA350 400A: BZ6TA400	Up to 350A: BZ6TA350 400A: BZ6TA400	

Notes: *1 Icu: Rated ultimate short-circuit breaking capacity
Ics: Rated service short-circuit breaking capacity
*2 Interphase insulation barriers are standard provided for the front mounting type breakers.

● Available – Not available ▲ Factory-mounted accessory

Molded Case Circuit Breakers

Quick reference guide

UL Listed

■ S series/3-pole UL489 Listed

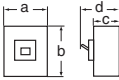
Frame		600A	800A		
Pole		3	3		
Type	Page 06/44	SA603RCUL	SA803RCUL		
Rated current (A)		500, 600	700, 800		
Rated insulation voltage [IEC 60947-2] (V AC)		690	690		
Rated operating voltage [UL489] (V AC)		480	480		
Rated breaking capacity (kA)	UL489 (cUL)	480V	50		
		480Y/277V	50		
		240V	85		
	IEC 60947-2 (Icu/Ics) *1	600V AC	30/15	35/15	
		500V AC	35/18	35/18	
		JIS C8201-2	440V AC	50/25	50/25
			415V AC	50/25	50/25
		400V AC	50/25	50/25	
		380V AC	50/25	50/25	
230V AC	85/43	85/43			
250V DC	40/20	40/20			
Dimensions (mm)		a	210		
		b	275		
		c	103		
		d	146		
Page 06/77					
Mass (kg) Front mounting type		9	10		
Tripping device		Thermal-magnetic	Thermal-magnetic		
Connecting terminal	Screw	—	—		
	Flat	●	●		
	Block	●	●		
Internal accessories	See page 06/88				
Alarm switch	K	▲	▲		
Alarm switch with terminal block	KA	▲	▲		
Auxiliary switch	W	▲	▲		
Auxiliary switch with terminal block	WA	▲	▲		
Undervoltage trip with terminal block	RA	▲	▲		
Shunt trip	F	▲	▲		
Shunt trip with terminal block	FA	▲	▲		
External accessories					
Handle padlocking device Cap type	Q1	▲	▲		
Operating handle N-type	N BZ6N70CP		BZ6N70CP		
Operating handle V-type	V BZ6V70C		BZ6V70C		
Terminal cover Short	TS	—	—		
Terminal cover Long	TB BZ-TB70B		BZ-TB70B		
Terminal cover for flat terminal	TL	—	—		
Insulation barrier Interphase *2	B B-43A		B-43A		
Handle locking cover	L BZ-L70B		BZ-L70B		
Flat terminal	S BZ-SU70B-600		BZ-SU70B-800		
Block terminal	TA BZ-TA600		700A: BZ-TA700 800A: BZ-TA800		

Notes: *1 Icu: Rated ultimate short-circuit breaking capacity

Ics: Rated service short-circuit breaking capacity

*2 Interphase insulation barriers are standard provided for the front mounting type breakers.

● Available – Not available ▲ Factory-mounted accessory

■ E series/2, 3-pole UL489 Listed

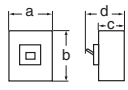
Frame	100A			
Pole	2	3		
Type	Page 06/44 EA102CUL	EA103CUL		
Rated current (A)	60, 70, 75, 80, 90, 100			
Rated insulation voltage [IEC 60947-2] (V AC)	690			
Rated operation voltage [UL489] (V AC)	240			
Rated breaking capacity (kA)	UL489 (cUL)	480Y/277V 240V	– 14	
	IEC 60947-2 (Icu/Ics) *1	600V AC	5/3	
		500V AC	7.5/4	
		JIS C8201-2	440V AC	10/5
		415V AC	10/5	
		400V AC	10/5	
		380V AC	10/5	
		230V AC	25/13	
250V DC	–	–		
Dimensions (mm)		a	50	75
		b	120	100
		c	60	60
		d	84	84
Mass (kg) Front mounting type	0.5		0.6	
Tripping device	Hydraulic-magnetic			
Connecting terminal	Screw	●	●	
	Flat	●	●	
	Block	–	–	
Internal accessories	See page 06/88			
Alarm switch	K	BZ6KR10CU	BZ6K□10CU	
Alarm switch with terminal block	KA	BZ6KR10CAU	BZ6K□10CAU	
Auxiliary switch	W	BZ6WR10CU	BZ6W□10CU	
Auxiliary switch with terminal block	WA	BZ6WR10CAU	BZ6W□10CAU	
Undervoltage trip with terminal block	RA	BZ6R□10CAU	BZ6R□10CAU	
Shunt trip	F	BZ6F□10CU	BZ6F□10CU	
Shunt trip with terminal block	FA	BZ6F□10CAU	BZ6F□10CAU	
External accessories				
Handle padlocking device Cap type	Q1	▲	▲	
Operating handle N-type	N	BZ6N10CP	BZ6N10CP	
Operating handle V-type	V	BZ6V10C	BZ6V10C	
Terminal cover Short	TS	Provided	Provided	
Terminal cover Long	TB	BZ6TB10CU2	BZ6TB10CU3	
Terminal cover for flat terminal	TL	–	–	
Insulation barrier Interphase	B	–	–	
Handle locking cover	L	BZ6L10C	BZ6L10C	
Flat terminal	S	BZ-SU20B	BZ-SU20B	
Block terminal	TA	–	–	

Notes: *1 Icu: Rated ultimate short-circuit breaking capacity
Ics: Rated service short-circuit breaking capacity

● Available – Not available ▲ Factory-mounted accessory

Molded Case Circuit Breakers

UL Listed MCCB selection

■ Circuit configuration and breaker application for control panels of industrial machinery in North America.

● UL508A (Industrial control panels) requirements

1. The requirements of NFPA70 (NEC), NFPA79, and applicable UL standards must be satisfied.
2. Positioning of protective equipment
 - Install branch circuit protection (BCP) for the main circuit at the point of electrical inlet.
 - Use equipment that is UL508 listed as applicable to each kind of loads, installed under appropriate load conditions, as protective equipment for load circuits used in branch circuits downstream from the BCP.



UL508/Group Installation, which combines UL489 Listed SA/EA-UL series and UL508 Listed Manual Motor Controllers (MMCs), complies with the UL508A requirements for North American industrial control panels.

● Application of UL489 Listed SA/EA-UL series and UL508 Listed MMCs (Group installation)

1. For group installations, if the UL489 Listed SA/EA-UL series is installed at the power inlet point (upstream) and any of the following conditions is satisfied in the circuit, a UL508 Listed MMC can be used as a downstream multi-circuit protective device. (In accordance with NEC430.53.)
 - a. No conductor to the motor shall have an ampacity less than that of the branch-circuit conductors.
 - b. No conductor to the motor shall have an ampacity less than one-third than of the branch-circuit conductors, the conductors to the motor overload device being not more than 7.5m(25ft) long and being protected from physical damage.
 - c. Conductors from the branch-circuit short-circuit and ground-fault protective device to a listed manual motor controller shall be permitted to have an ampacity not less than 1/10 the rating or setting of the branch-circuit short-circuit and ground-fault protective device. The conductors from the branch-circuit short-circuit and ground-fault protective device to the controller shall (1) be suitably protected from physical damage and enclosed either by an enclosed controller or by a raceway and shall be not more than 3m(10ft) long or (2) shall have an ampacity not less than that of the branch circuit conductors.
2. The UL508 Listed MMC also has UL508 Group Installation certification.
3. See NEC 430.53 for detail.
4. Refer to the table on the next page for breaking capacity of the UL508 Listed Group Installation when making your selection.

Item NEC430.53 Group Installation

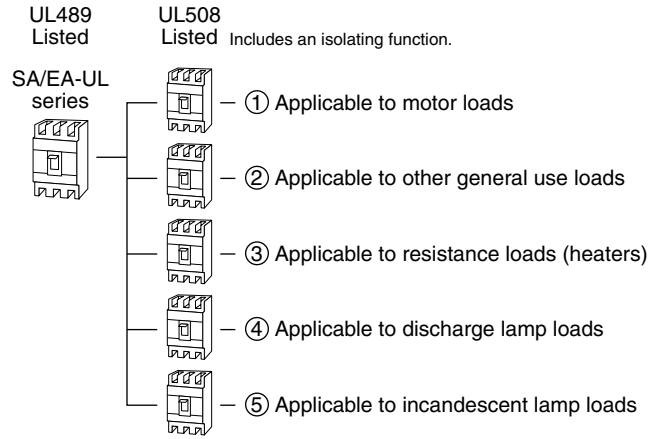

MAN.MTR.CNTR.
Suitable as motor disconnect

UL US LISTED MAN.MTR.CNTRLR. 27TB

Max CB800A
Short Circuit Rating
RMS.SYM 5kA 600V

For Group Installation see catalogue

<Suitable for the following loads>
- Across the line motor

VAC	220-240	440-480	550-600
HP 3ph	15	30	40
Hp ph	7.5	20	25

WARNING
TO MAINTAIN OVERCURRENT SHORT CIRCUIT AND GROUND FAULT PROTECTION, THE MANUFACTURER'S INSTRUCTIONS FOR SELECTION OF OVERLOAD AND SHORT CIRCUIT PROTECTION MUST BE FOLLOWED. TO REDUCE THE RISK OF FIRE OR ELECTRIC SHOCK.

- AC General Use Rating 100 A
- AC Resistance(heating) 100 A
- AC Discharge Lamps 50 A
- AC Incandescent Lamps 100 A

Use 75°C Cu-wire only
Torque 5.5~7.5 N·m
50~65 lb·in

■ Group Installation

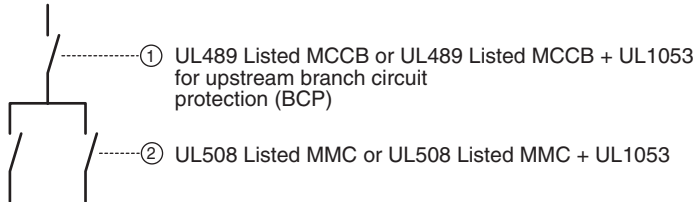

● 240V AC for UL508 Listed MMC (② in figure) combined with UL489 Listed MCCB (+ UL1053) (① in figure)

② UL508 Listed MMCs	① UL489 Listed MCCBs (+ UL1053)					
	SA53RCUL SG53RCUL	SA103CUL SA103RCUL SG103CUL EA103CUL EG103CUL	SA203CUL SA203RCUL SG203CUL	SA403CUL SA403RCUL	SA603RCUL	SA803RCUL
SA30C	5kA	5kA	5kA	5kA	—	—
SA50C	10kA	10kA	10kA	10kA	—	—
SA50RC	25kA	25kA	25kA	25kA	—	—
SA60C	10kA	10kA	10kA	10kA	10kA	10kA
SA60RC	25kA	25kA	25kA	25kA	25kA	25kA
EA30AC	5kA	5kA	5kA	5kA	—	—
EA50AC	5kA	5kA	5kA	5kA	—	—
EA50C	5kA	5kA	5kA	5kA	—	—
EA60C	5kA	5kA	5kA	5kA	5kA	5kA
EA100AC	5kA	5kA	5kA	5kA	5kA	5kA
EA100C	25kA	25kA	25kA	25kA	25kA	25kA

● 480V AC for UL508 Listed MMC (② in figure) combined with UL489 Listed MCCB (+ UL1053) (① in figure)

② UL508 Listed MMCs	① UL489 Listed MCCBs (+ UL1053)				
	SA103RCUL	SA203RCUL	SA403RCUL	SA603RCUL	SA803RCUL
SA30C	5kA	5kA	5kA	—	—
SA50C	10kA	10kA	10kA	—	—
SA50RC	10kA	10kA	10kA	—	—
SA60C	10kA	10kA	10kA	10kA	10kA
SA60RC	10kA	10kA	10kA	10kA	10kA
EA50C	5kA	5kA	5kA	—	—
EA60C	5kA	5kA	5kA	5kA	5kA
EA100C	10kA	10kA	10kA	10kA	10kA

● 240V AC for UL508 Listed MMC + UL1053 (② in figure) combined with UL489 Listed MCCB (+ UL1053) (① in figure)

② UL508 Listed MMCs + UL1053	① UL489 Listed MCCBs (+ UL1053)					
	SA53RCUL SG53RCUL	SA103CUL SA103RCUL SG103CUL EA103CUL EG103CUL	SA203CUL SA203RCUL SG203CUL	SA403CUL SA403RCUL	SA603RCUL	SA803RCUL
SG33C	5kA	5kA	10kA	5kA	—	—
SG53C	10kA	10kA	25kA	10kA	—	—
SG53RC	25kA	25kA	10kA	25kA	—	—
SG63C	10kA	10kA	25kA	10kA	10kA	10kA
SG63RC	25kA	25kA	5kA	25kA	25kA	25kA
EG32AC, EG33AC	5kA	5kA	5kA	5kA	—	—
EG33C	5kA	5kA	5kA	5kA	—	—
EG52AC, EG53AC	5kA	5kA	5kA	5kA	—	—
EG53C	5kA	5kA	5kA	5kA	—	—
EG63C	5kA	5kA	5kA	5kA	5kA	5kA
EG102AC, EG103AC	5kA	5kA	25kA	5kA	5kA	5kA
EG103C	25kA	25kA	—	25kA	25kA	25kA

Molded Case Circuit Breakers

MCCB selection

UL Listed

■ S series UL/cUL508 Listed (File No.E216772)

Frame		30A						50A													
Pole		2			3			2			3										
Type		SA32C□-CE			SA33C□-CE			SA52C□-CE			SA53C□-CE			SA52RC□-CE			SA53RC□-CE				
Rated operating voltage (V AC)		550						600						600							
Max. motor ratings (HP) UL508 [cUL] ^{*1}	Rated current (A)	3	5	10	15	20	30	5	10	15	20	30	40	50	10	15	20	30	40	50	
		3-phase	550 (-600) V AC ^{*2}	3/4	1	3	5	7.5	10	1	3	5	7.5	10	15	20	3	5	7.5	10	15
	440-480V AC	0.5	1	2	3	5	10	1	2	3	5	10	10	15	2	3	5	10	10	15	
	220-240V AC	–	0.5	1	2	2	3	0.5	1	2	2	3	5	7.5	1	2	2	3	5	7.5	
	110-120V AC	–	–	–	–	–	–	–	–	–	–	–	–	–	–	–	–	–	–		
	Single-phase	550 (-600) V AC ^{*2}	–	0.5	1.5	3	3	5	0.5	1.5	3	3	5	7.5	10	1.5	3	3	5	7.5	10
	440-480V AC	–	–	1	2	3	5	–	1	2	3	5	5	7.5	1	2	3	5	5	7.5	
	220-240V AC	–	1/6	1/3	3/4	1	2	1/6	1/3	3/4	1	2	3	3	1/3	3/4	1	2	3	3	
	110-120V AC	–	–	–	–	–	–	–	–	–	–	–	–	–	–	–	–	–	–		
Load (A) UL508 [cUL]	Resistance ^{*3}	3, 5, 10, 15, 20, 30						5, 10, 15, 20, 30, 40, 50						10, 15, 20, 30, 40, 50							
	Discharge lamp ^{*4}	1.5, 2.5, 5, 7.5, 10, 15						2.5, 5, 7.5, 10, 15, 20, 25						5, 7.5, 10, 15, 20, 25							
	Incandescent lamp ^{*3}	3, 5, 10, 15, 20, 30						5, 10, 15, 20, 30, 40, 50						10, 15, 20, 30, 40, 50							
	Others ^{*3}	3, 5, 10, 15, 20, 30						5, 10, 15, 20, 30, 40, 50						10, 15, 20, 30, 40, 50							

Frame		60A												
Pole		2			3									
Type		SA62C□-CE			SA63C□-CE			SA62RC□-CE			SA63RC□-CE			
Rated operating voltage (V AC)		600												
Max. motor ratings (HP) UL508 [cUL] ^{*1}	Rated current (A)	60						60						
		3-phase	550 (-600) V AC ^{*2}	25						25				
	440-480V AC	20						20						
	220-240V AC	10						10						
	110-120V AC	–						–						
	Single-phase	550 (-600) V AC ^{*2}	15						15					
	440-480V AC	10						10						
	220-240V AC	5						5						
	110-120V AC	–						–						
Load (A) UL508 [cUL]	Resistance ^{*3}	60						60						
	Discharge lamp ^{*4}	30						30						
	Incandescent lamp ^{*3}	60						60						
	Others ^{*3}	60						60						

Notes: ^{*1} The performance of UL508 approved models is indicated as applicable motor rating (HP).

^{*2} Rated operating voltage 550-600V AC: For SA50C, 50RC, 60C and 60RC.

^{*3} Rated current x 1

^{*4} Rated current x 1/2

Molded Case Circuit Breakers
MCCB selection
UL Listed

■ E series UL/cUL508 Listed (File No.E216772)

Frame		30A						50A																			
Pole		2			3			2					3														
Type		EA32AC□-CE			EA33AC□-CE			EA52AC□-CE					EA53AC□-CE														
Rated operating voltage (V AC)		240						240										550									
Max. motor ratings (HP) UL508 [cUL]*1	Rated current (A)		3	5	10	15	20	30	5	10	15	20	30	40	50	5	10	15	20	30	40	50					
		3-phase	550 (-600) V AC*2	-	-	-	-	-	-	-	-	-	-	-	-	-	1	3	5	7.5	10	15	20				
		440-480V AC	-	-	-	-	-	-	-	-	-	-	-	-	-	1	2	3	5	10	10	15					
		220-240V AC	-	0.5	1	2	2	3	0.5	1	2	2	3	5	7.5	0.5	1	2	2	3	5	7.5					
		110-120V AC	-	-	0.5	3/4	1	2	-	0.5	3/4	1	2	2	3	-	-	-	-	-	-	-					
	Single-phase	550 (-600) V AC*2	-	-	-	-	-	-	-	-	-	-	-	-	-	0.5	1.5	3	3	5	7.5	10					
		440-480V AC	-	-	-	-	-	-	-	-	-	-	-	-	-	-	1	2	3	5	5	7.5					
		220-240V AC	0.1	1/6	1/3	3/4	1	2	1/6	1/3	3/4	1	2	3	3	1/6	1/3	3/4	1	2	3	3					
		110-120V AC	-	-	1/6	1/4	1/3	3/4	-	1/6	1/4	1/3	3/4	1	1.5	-	-	-	-	-	-	-					
Load (A) UL508 [cUL]	Resistance *3		3, 5, 10, 15, 20, 30						5, 10, 15, 20, 30, 40, 50																		
	Discharge lamp *4		1.5, 2.5, 5, 7.5, 10, 15						2.5, 5, 7.5, 10, 15, 20, 25																		
	Incandescent lamp *3		3, 5, 10, 15, 20, 30						5, 10, 15, 20, 30, 40, 50																		
	Others *3		3, 5, 10, 15, 20, 30						5, 10, 15, 20, 30, 40, 50																		

Frame		60A						100A															
Pole		2			3			3				2				3							
Type		EA62C□-CE			EA63C□-CE			EA103AC□-CE				EA102C□-CE				EA103C□-CE							
Rated operating voltage (V AC)		550						240								600							
Max. motor ratings (HP) UL508 [cUL]*1	Rated current (A)		60			60			75		100			50		60		75		100			
		3-phase	550 (-600) V AC*2	25			-			-		-			20		25		30		40		
		440-480V AC	20			-			-		-			15		20		25		30			
		220-240V AC	10			10			10		15			7.5		10		10		15			
		110-120V AC	-			3			5		7.5			-		-		-		-			
	Single-phase	550 (-600) V AC*2	15			-			-		-			10		15		20		25			
		440-480V AC	10			-			-		-			7.5		10		15		20			
		220-240V AC	5			5			5		7.5			3		5		5		7.5			
		110-120V AC	-			2			3		3			-		-		-		-			
Load (A) UL508 [cUL]	Resistance *3		60			60, 75, 100								50, 60, 75, 100									
	Discharge lamp *4		30			30, 37.5, 50								25, 30, 37.5, 50									
	Incandescent lamp *3		60			60, 75, 100								50, 60, 75, 100									
	Others *3		60			60, 75, 100								50, 60, 75, 100									

Notes: *1 The performance of UL508 approved models is indicated as applicable motor rating (HP).

*2 Rated operating voltage 550-600V AC: For SA50C, 50RC, 60C and 60RC.

*3 Rated current x 1

*4 Rated current x 1/2

Molded Case Circuit Breakers

Mounting modifications

■ Mounting modifications

Standard type FUJI breakers are front mounting with front connections. The standard breaker can easily be modified to become front mounting rear connection type, flush mounting type and plug-in type. The additional parts such as insulation bases, barriers, covers and similar parts are added as required.

Standard type
Front mounting
Front connection



BASIC DESIGN

Mounting modification kits:

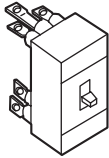
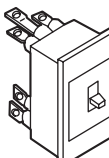
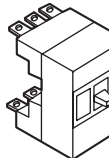
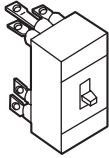
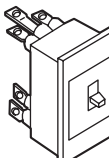
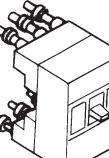
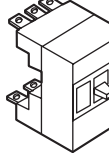
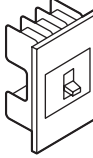

[See page 06/130](#)

Additional main parts	Front mounting Rear connection (X type)	Additional main parts	Flush mounting Rear connection (E type)	Additional main parts	Plug-in mounting (P type)
 Bar stud terminal	SA30C EA30AC SA50C EA50C SA50RC EA50AC SA60C EA60C SA60RC EA100C EA100AC	 Bar stud terminal	SA30C EA30AC SA50C EA50C SA50RC EA50AC SA60C EA60C SA60RC EA100C EA100AC	 Bar stud terminal	SA30C EA30AC SA50C EA50C SA50RC EA50AC SA60C EA60C SA60RC EA100C EA100AC
 Bar stud terminal	SA100C EA225C SA100RC EA400C SA225C EA600C SA225RC EA800C SA400C SA400RC SA600RC SA800RC	 Bar stud terminal	SA100C EA225C SA100RC EA400C SA225C EA600C SA225RC EA800C SA400C SA400RC SA600RC SA800RC	 Round stud terminal	SA100C SA100RC
	Each stud can be turned by 90°		Each stud can be turned by 90°		
		Additional main parts	Flush mounting Top and bottom connection (Y type)	 Bar stud terminal	SA225C EA225C SA225RC EA400C SA400C EA600C SA400RC EA800C SA600RC SA800RC
		 Decorative flush plate	SA30C EA30AC SA50C EA50C SA50RC EA50AC SA60C EA60C SA60RC EA100C EA100AC		Each stud can be turned by 90°

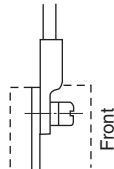
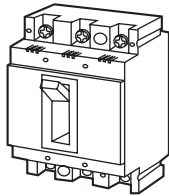
■ Terminal connection/Front mounting, front connection



Flat terminal

Self lifting screw	Breaker type	Size
	SA30C EA30AC SA50C EA50AC SA50RC EA50C	M5 × 14
	SA60C EA60C SA60RC EA100AC EA100C	M8 × 15

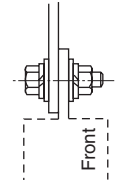
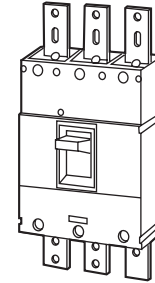
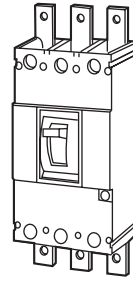

Flat terminal

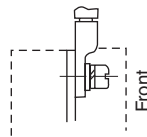
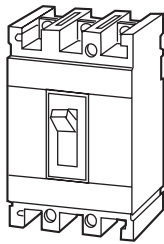

Hexagonal head bolt	Breaker type	Size
	SA400C EA400C SA400RC	M12 × 35
	SA600RC EA600C SA800RC EA800C	M12 × 40

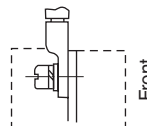

or



Flat terminal

Self lifting screw	Breaker type	Size
	SA100C SA100RC	M8 × 14
	SA225C EA225C SA225RC	M8 × 16

Type of connection/up to 225AF

Front mounting front connection

Direct connection

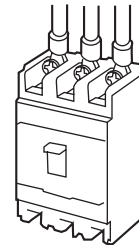
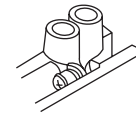

Flat terminal connection

Flat terminals are required.

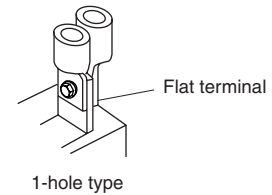

Flat bar studs/1-hole type

Breaker type	Pole	Type of flat terminal
SA30C, SA50C, SA50RC EA30AC, EA50AC, EA50C	2 3	BZ6S10C502 BZ6S10C503
SA60C, SA60RC EA60C, EA100C *	2 3	BZ6S10C1002 BZ6S10C1003
SA100C, SA100RC	2 3	BZ-S35B-1002 BZ-S35B-1003
SA225C, SA225RC EA225C	2 3	BZ-S50B-2252 BZ-S50B-2253

* EA100C breaker of rated current 50A: BZ6S10C502 or 503.

Molded Case Circuit Breakers

Wire size and terminal

■ Wire size and crimp terminal

The following is the size recommendations for crimp terminals.

Crimp terminal R : JIS C2805
 CB : JEM-1399
 JST : Product of Japan Crimp Terminal Co., Ltd.
 F : FUJI special crimp terminal

Ampere frame	Breaker	Wire size(mm ²)											
		1.04 2.63	2.63 6.64	6.64 10.52	10.52 16.78	16.78 26.66	26.66 42.42	42.42 60.57	60.57 96.3	96.3 117.2	117.2 152.05	152.05 192.6	192.6 242.27
30	EA30AC SA30C	R2-5	R5.5-5	R8-5	R14-5								
50	SA50C, SA50RC EA50AC, EA50C LA50B	R2-5	R5.5-5	R8-5	R14-5								
	H50BA	R2-8	R5.5-8	R8-8	R14-8	JST22-S8							
60	SA60C, SA60RC EA60C	R2-8	R5.5-8	R8-8	R14-8	JST22-S8							
100	SA100C, SA100RC H100BA, H100R	R2-8	R5.5-8	R8-8	R14-8	R22-8	JST38-S8	CB60-8					
	EA100AC EA100C	R2-8	R5.5-8	R8-8	R14-8	JST22-S8	JST38-S8	F60-8					
225	EA225C SA225C, SA225RC H225BA, H225R				R14-8	R22-8	R38-8	R60-8	CB100-8	CB150			
400	SA400C, SA400RC EA400C H400B, H400R						R38-12	R60-12	R100-12	R150-12	R200-12	JST325-12	
600	SA600RC EA600C H600B, H600R								R100-12	R150-12	R200-12	JST325-12	
800	SA800RC EA800C H800B, H800R								R100-12	R150-12	R200-12	JST325-12	
1000 1200	SA1000E SA1200E								R100-12	R150-12	R200-12	JST325-12	
1600	SA1600E								R100-12	R150-12	R200-12	JST325-12	

Note: For solid-state trip types, same as the standard types.

Block terminal connection (For UL Listed)

MCCB type	Rated current (A)	Connectable wire size	Tightening torque (N·m)	Type of screw head and size (mm)
SA100CUL SA100RCUL	15	14AWG	5.8 (5.8 to 6.4)	Slotted head screw
	20	12AWG		
	30	10AWG		
	40	8AWG		
	45	8AWG		
	50	8AWG		
	60	6AWG		
	75	4AWG		
SA225CUL SA225RCUL	100	3AWG	23 (23 to 25.3)	Hexagonal socket head bolt 6.35mm (1/4 inch)
	125	1AWG		
	150	1/0AWG		
	175	2/0AWG		
	200	3/0AWG		
SA400CUL SA400RCUL	225	4/0AWG	43.5 (43.5 to 48)	Hexagonal socket head bolt 9.53mm (3/8 inch)
	250	250kcmil		
	300	350kcmil		
	350	500kcmil		
SA600RCUL	400	3/0AWG x2	31.9 (31.9 to 35.1)	Hexagonal socket head bolt 8mm (5/16 inch)
	500	250-500kcmil x2		
SA800RCUL	600	250-500kcmil x2	31.07 (31.07 to 34.2)	
	700	250-500kcmil x2		
	800	3/0AWG-300kcmil x3		







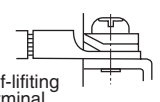
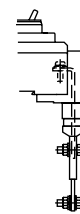
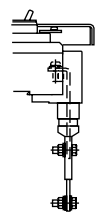
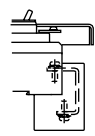
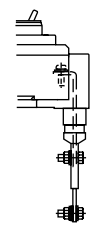
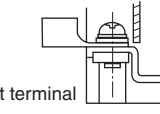

Notes: • AWG is abbreviation of "American Wire Gauge" and the UL approved wire unit.
 • The allowable temperature of wire is 75°C. (UL CSA approved)

Crimp terminal connection (For UL Listed)

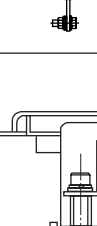
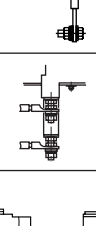
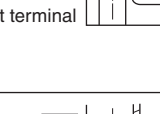
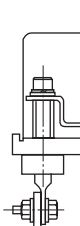
MCCB type	Rated current (A)	Applicable crimp terminal								Connectable wire size (AWG)		Tightening torque (N·m)	Type of screw head and size (mm)
		J.S.T. Mfg. Co., Ltd		Aikoku Kogyo K.K.		Nichifu Co., Ltd.		Daido Solderless Terminal Mfg. Co., Ltd.		60°C wire	75°C wire		
		60°C wire	75°C wire	60°C wire	75°C wire	60°C wire	75°C wire	60°C wire	75°C wire				
SA50RCUL	3		R2-5		R2-5						14AWG	2.3-2.8	Cross-recessed pan-head screw M5 x 14
	5												
	10												
	15												
	20										12AWG		
	30		R5.5-5		R5.5-5						10AWG		
	40		R8-5		R8-5						8AWG		
EA100CUL	60		R14-8		R14-8						6AWG	5.5-7.5	Cross-recessed pan-head screw M8 x 14
	75		22-S8		22-8						4AWG		
	100		38-S8		38-8S						3AWG		
SA100CUL	30	R5.5-8	R5.5-8	R5.5-8	R5.5-8	R5.5-8	R5.5-8	R5.5-8	R5.5-8	10AWG	10AWG	5.8 (5.3-6.4)	Cross-recessed pan-head screw M8 x 14
SA100RCUL	40	R8-8	R8-8	R8-8	R8-8	R8-8	R8-8	R8-8	R8-8	8AWG	8AWG		
	45	R14-8	R14-8	R14-8	R14-8	R14-8	R14-8	R14-8	R14-8	6AWG	6AWG		
	50												
	60	22-S8		22-8		22-8S		22-8S		4AWG	4AWG		
	70		22-S8		22-8		22-8S		22-8S		4AWG		
	75							38-8S		3AWG			
	80												
	90	38-S8	38-S8	38-8S	38-8S	38-8S	38-8S		38-8S	2AWG	3AWG		
100									1AWG	1AWG			
SA225CUL	125		38-S8		38-8S		R38-8S		38-8S		1AWG	10.5 (8-13)	Hexagonal socket head bolt M8 x 16
SA225RCUL	150		R60-8		R60-8		R60-8		60-8		1/0AWG		
	175		70-8				R70-8		70-8		2/0AWG		
	200		CB80-S8						CB80-S8		3/0AWG		
	225		CB100-S8						CB100-S8		4/0AWG		

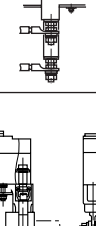
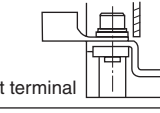
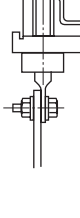
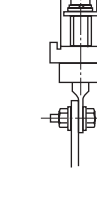
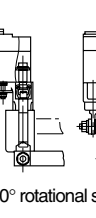
Notes: • AWG is abbreviation of "American Wire Gauge" and the UL approved wire unit.
 • The allowable temperature of wire is 75°C. (UL CSA approved)

■ Breaker termination

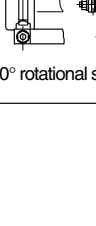
MCCB type	Front connection	Rear connection X	Flush mounting E	Y	Plug-in mounting P
SA30AC, SA50C, SA50RC EA30AC, EA50C, EA50AC	 Self-lifting terminal				
SA60C, SA60RC EA60C, EA100C, EA100AC					
SA100C, SA100RC					
SA225C, SA225RC EA225C					
SA400C, SA400RC SA600RC, SA800RC EA400C, EA600C, EA800C					 90° rotational stud

Molded Case Circuit Breakers

Type number nomenclature

■ Type number nomenclature

● IEC and CE marking conformed / Up to 800AF

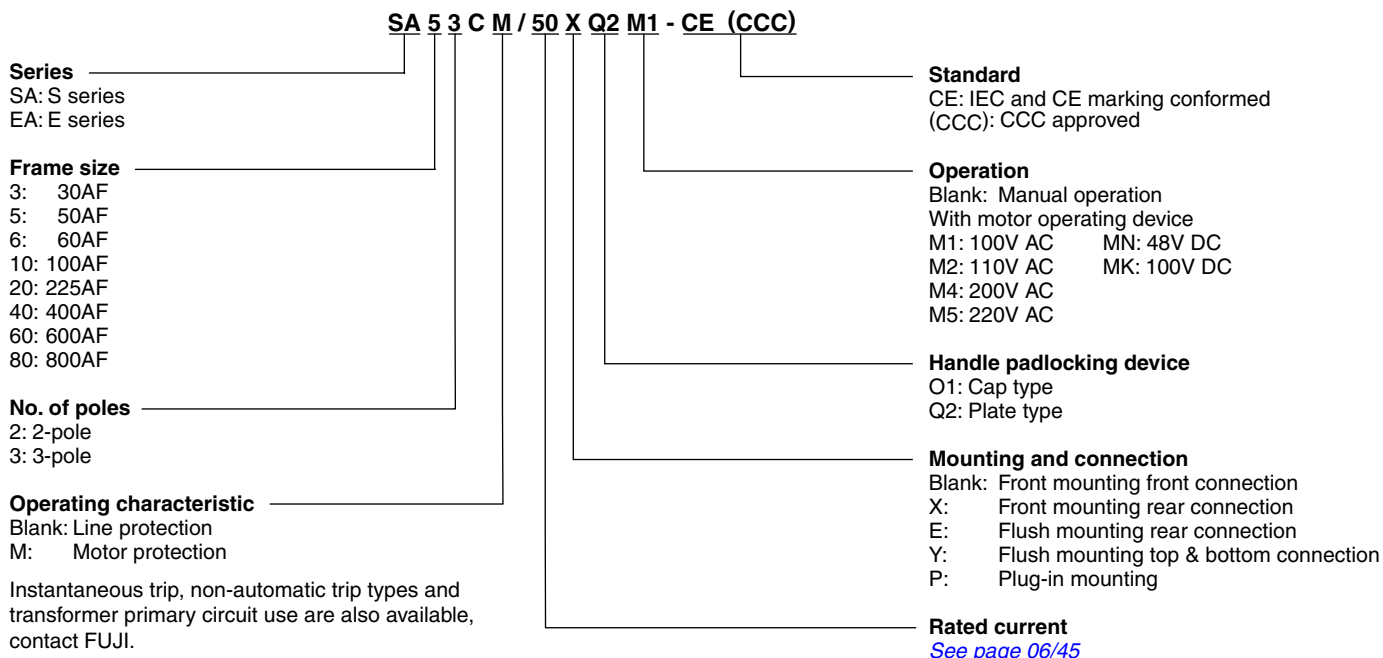

■ Ordering information

Specify the following:

1. Type number of MCCB including factory-mounted optional accessories
2. Type number of customer-mountable optional accessories

■ Customer-mountable optional accessories/Sold separately

Internal accessories

Auxiliary switch, alarm switch, shunt trip device, undervoltage trip device (except for SA100, SA225, EA225), terminal block

External accessories

Operating handles (N and V-type), terminal covers, insulation barrier, steel enclosures, handle locking covers, kits for mounting modification, flat terminal, mechanical interlock device

■ Factory-mounted accessories

External accessories

Handle padlocking devices/Q1 and Q2, motor-operating mechanism/M, under voltage trip device for SA100, SA225 and EA225 only

Further information: [See page 06/88.](#)

• Example

S series	SA
3-pole, 660V, 100A Frame	103C
Rated current 75A	75
Front mounting, front connection	Blank
IEC and CE marking conformed	CE

Complete type number **SA103C/75-CE**

■ Type number nomenclature

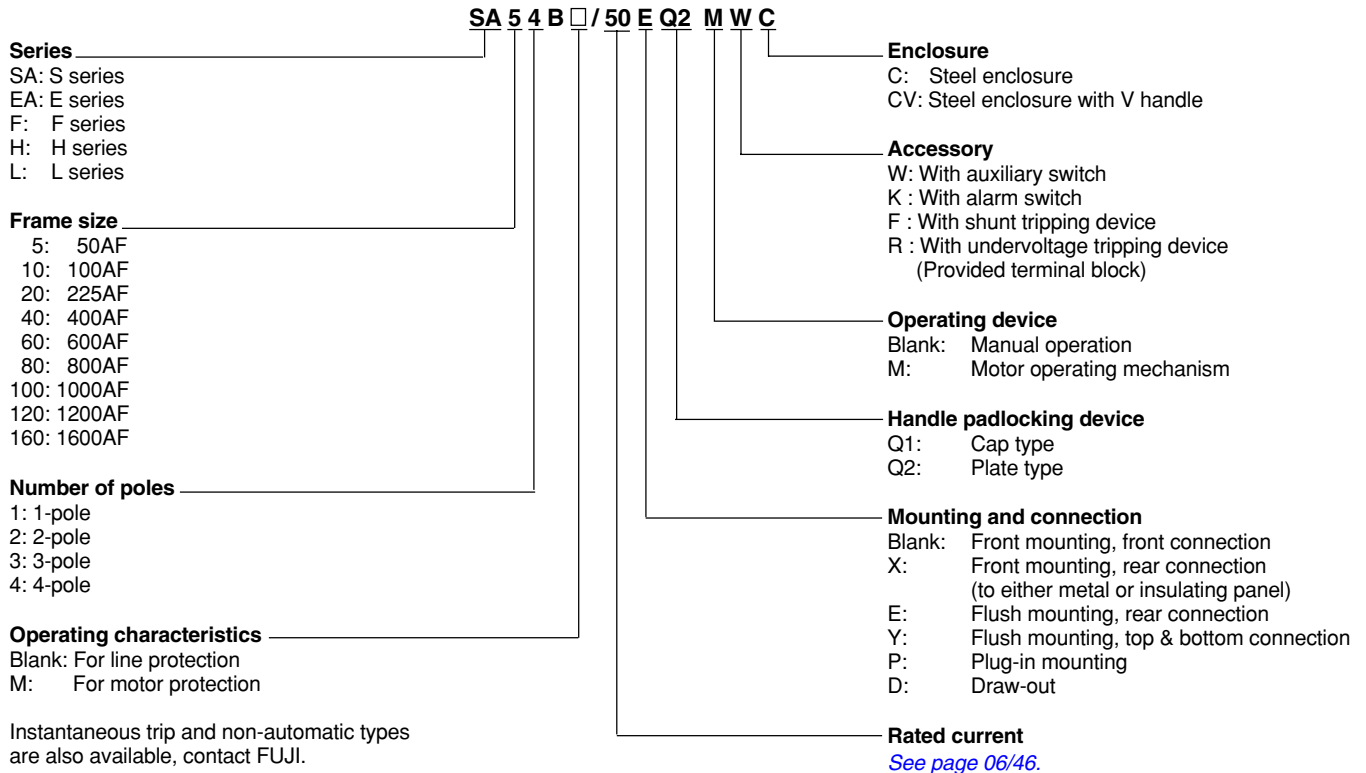

■ Ordering information

Specify the following:

1. Type number
2. Optional accessories
Lead wire or terminal block connection
3. When ordering MCCB with shunt tripping device, undervoltage tripping device or motor operating mechanism, specify rated voltage and frequency.
4. Handle type if required

Molded Case Circuit Breakers

Type number nomenclature

■ Type number nomenclature

● UL489 Listed

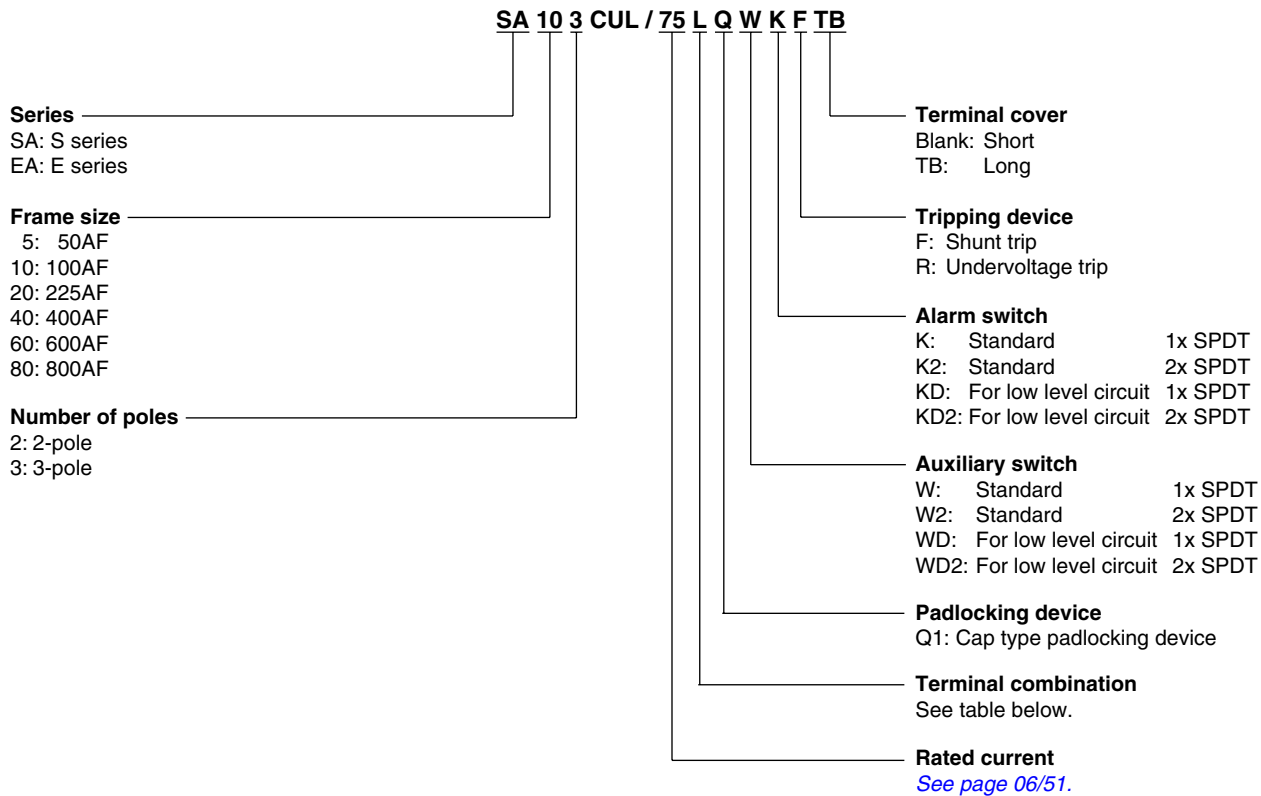

■ Terminal combination

Code	Terminal position		Applicable breaker type				
	Line	Load	SA50RCUL EA100CUL	SA100CUL SA100RCUL SA225CUL SA225RCUL	SA400CUL SA400RCUL	SA600RCUL SA800RCUL/700	SA800RCUL/800
Blank	Screw	Screw	●	●	—	—	—
L	Block terminal	Block terminal	—	●	●	●	●
L1	Flat terminal	Flat terminal	●	●	●	●	—
L3	Screw	Flat terminal	●	●	—	—	—
L4	Flat terminal	Screw	●	●	—	—	—
L5	Screw	Block terminal	—	●	—	—	—
L6	Block terminal	Screw	—	●	—	—	—
L7	Flat terminal	Block terminal	—	●	●	●	—
L8	Block terminal	Flat terminal	—	●	●	●	—

● Available — Not available

● S series, 2-pole IEC and CE marking conformed

Breaker ampere frame	Rated current (A)	Type	□ : Available mounting and connection		
30	3	SA32C/3□-CE	Blank, X, E, Y, P		
	5	SA32C/5□-CE			
	10	SA32C/10□-CE			
	15	SA32C/15□-CE			
	20	SA32C/20□-CE			
	30	SA32C/30□-CE			
50	5	SA52C/5□-CE	Blank, X, E, Y, P		
	10	SA52C/10□-CE			
	15	SA52C/15□-CE			
	20	SA52C/20□-CE			
	30	SA52C/30□-CE			
	40	SA52C/40□-CE			
	50	SA52C/50□-CE			
	10	10	SA52RC/10□-CE	Blank, X, E, Y, P	
		15	SA52RC/15□-CE		
		20	SA52RC/20□-CE		
		30	SA52RC/30□-CE		
		40	SA52RC/40□-CE		
50		SA52RC/50□-CE			
60	60	SA62C/60□-CE	Blank, X, E, Y, P		
		SA62RC/60□-CE	Blank, X, E, Y, P		
100	15	SA102C/15□-CE	Blank, X, E, P		
	20	SA102C/20□-CE			
	30	SA102C/30□-CE			
	40	SA102C/40□-CE			
	50	SA102C/50□-CE			
	60	SA102C/60□-CE			
	75	SA102C/75□-CE			
	100	SA102C/100□-CE			
	15	15		SA102RC/15□-CE	Blank, X, E, P
		20		SA102RC/20□-CE	
		30		SA102RC/30□-CE	
		40		SA102RC/40□-CE	
		50		SA102RC/50□-CE	
		60		SA102RC/60□-CE	
75		SA102RC/75□-CE			
100		SA102RC/100□-CE			
225	125	SA202C/125□-CE	Blank, X, E, P		
	150	SA202C/150□-CE			
	175	SA202C/175□-CE			
	200	SA202C/200□-CE			
	225	SA202C/225□-CE			
	125	SA202RC/125□-CE		Blank, X, E, P	
150	SA202RC/150□-CE				
175	SA202RC/175□-CE				
200	SA202RC/200□-CE				
225	SA202RC/225□-CE				
400	250	SA402C/250□-CE	Blank, X, E, P		
	300	SA402C/300□-CE			
	350	SA402C/350□-CE			
	400	SA402C/400□-CE			
	250	250	SA402RC/250□-CE	Blank, X, E, P	
		300	SA402RC/300□-CE		
		350	SA402RC/350□-CE		
		400	SA402RC/400□-CE		

Mounting	Connection	□
Front	Front	Blank
Front	Rear	X
Flush	Rear	E
Flush	Top and bottom	Y
Plug-in		P
Draw-out		D

● S series, 3-pole IEC and CE marking conformed

Breaker ampere frame	Rated current (A)	Type	□ : Available mounting and connection		
30	3	SA33C/3□-CE	Blank, X, E, Y, P		
	5	SA33C/5□-CE			
	10	SA33C/10□-CE			
	15	SA33C/15□-CE			
	20	SA33C/20□-CE			
	30	SA33C/30□-CE			
50	5	SA53C/5□-CE	Blank, X, E, Y, P		
	10	SA53C/10□-CE			
	15	SA53C/15□-CE			
	20	SA53C/20□-CE			
	30	SA53C/30□-CE			
	40	SA53C/40□-CE			
	50	SA53C/50□-CE			
	10	10	SA53RC/10□-CE	Blank, X, E, Y, P	
		15	SA53RC/15□-CE		
		20	SA53RC/20□-CE		
		30	SA53RC/30□-CE		
		40	SA53RC/40□-CE		
50		SA53RC/50□-CE			
60	60	SA63C/60□-CE	Blank, X, E, Y, P		
		SA63RC/60□-CE	Blank, X, E, Y, P		
100	15	SA103C/15□-CE	Blank, X, E, P		
	20	SA103C/20□-CE			
	30	SA103C/30□-CE			
	40	SA103C/40□-CE			
	50	SA103C/50□-CE			
	60	SA103C/60□-CE			
	75	SA103C/75□-CE			
	100	SA103C/100□-CE			
	15	15		SA103RC/15□-CE	Blank, X, E, P
		20		SA103RC/20□-CE	
		30		SA103RC/30□-CE	
		40		SA103RC/40□-CE	
		50		SA103RC/50□-CE	
		60		SA103RC/60□-CE	
75		SA103RC/75□-CE			
100		SA103RC/100□-CE			
225	125	SA203C/125□-CE	Blank, X, E, P		
	150	SA203C/150□-CE			
	175	SA203C/175□-CE			
	200	SA203C/200□-CE			
	225	SA203C/225□-CE			
	125	SA203RC/125□-CE		Blank, X, E, P	
150	SA203RC/150□-CE				
175	SA203RC/175□-CE				
200	SA203RC/200□-CE				
225	SA203RC/225□-CE				
400	250	SA403C/250□-CE	Blank, X, E, P		
	300	SA403C/300□-CE			
	350	SA403C/350□-CE			
	400	SA403C/400□-CE			
	250	250	SA403RC/250□-CE	Blank, X, E, P	
		300	SA403RC/300□-CE		
		350	SA403RC/350□-CE		
		400	SA403RC/400□-CE		
600	500	SA603RC/500□-CE	Blank, X, E, P, D		
	600	SA603RC/600□-CE			
800	700	SA803RC/700□-CE	Blank, X, E, P, D		
	800	SA803RC/800□-CE			

Molded Case Circuit Breakers

Type number

Line protection

● S series, 4-pole

Breaker ampere frame	Rated current (A)	Type	□ : Available mounting and connection
50	5	SA54B/5□	Blank, X, E, Y Blank, X, E, Y Blank, X, E, Y Blank, X, E, Y Blank, X, E, Y Blank, X, E, Y
	10	SA54B/10□	
	15	SA54B/15□	
	20	SA54B/20□	
	30	SA54B/30□	
	40	SA54B/40□	
	50	SA54B/50□	
100	15	SA104R/15□	Blank, X, E Blank, X, E Blank, X, E Blank, X, E Blank, X, E Blank, X, E Blank, X, E Blank, X, E
	20	SA104R/20□	
	30	SA104R/30□	
	40	SA104R/40□	
	50	SA104R/50□	
	60	SA104R/60□	
	75	SA104R/75□	
	100	SA104R/100□	
225	125	SA204R/125□	Blank, X, E Blank, X, E Blank, X, E Blank, X, E Blank, X, E
	150	SA204R/150□	
	175	SA204R/175□	
	200	SA204R/200□	
	225	SA204R/225□	
400	250	SA404HA/250□	Blank, X, E Blank, X, E Blank, X, E Blank, X, E
	300	SA404HA/300□	
	350	SA404HA/350□	
	400	SA404HA/400□	
600	500	SA604H/500□	Blank, X, E Blank, X, E
	600	SA604H/600□	
800	700	SA804H/700□	Blank, X, E Blank, X, E
	800	SA804H/800□	
1000	500 to 1000	SA1004/1000E□	Blank, X, E
1200	600 to 1200	SA1204/1200E□	Blank, X, E
1600	800 to 1600	SA1604E/1600□	Blank, X, E

● E series, 2-pole IEC and CE marking conformed

Breaker ampere frame	Rated current (A)	Type	□ : Available mounting and connection	
30	3	EA32AC/3□-CE	Blank, X, E, Y, P	
	5	EA32AC/5□-CE		
	10	EA32AC/10□-CE		
	15	EA32AC/15□-CE		
	20	EA32AC/20□-CE		
	30	EA32AC/30□-CE		
50	5	EA52AC/5□-CE	Blank, X, E, Y, P	
	10	EA52AC/10□-CE		
	15	EA52AC/15□-CE		
	20	EA52AC/20□-CE		
	30	EA52AC/30□-CE		
	40	EA52AC/40□-CE		
	50	EA52AC/50□-CE		
		5	EA52C/5□-CE	Blank, X, E, Y, P
		10	EA52C/10□-CE	
		15	EA52C/15□-CE	
	20	EA52C/20□-CE		
	30	EA52C/30□-CE		
60	60	EA62C/60□-CE	Blank, X, E, Y, P	
100	50	EA102C/50□-CE	Blank, X, E, Y, P	
	60	EA102C/60□-CE		
	75	EA102C/75□-CE		
	100	EA102C/100□-CE		
225	125	EA202C/125□-CE	Blank, X, E, P	
	150	EA202C/150□-CE		
	175	EA202C/175□-CE		
	200	EA202C/200□-CE		
	225	EA202C/225□-CE		
400	250	EA402C/250□-CE	Blank, X, E, P	
	300	EA402C/300□-CE		
	350	EA402C/350□-CE		
	400	EA402C/400□-CE		

● E series, 3-pole IEC and CE marking conformed

Breaker ampere frame	Rated current (A)	Type	□ : Available mounting and connection
30	3	EA33AC/3□-CE	Blank, X, E, Y, P
	5	EA33AC/5□-CE	
	10	EA33AC/10□-CE	
	15	EA33AC/15□-CE	
	20	EA33AC/20□-CE	
	30	EA33AC/30□-CE	
50	5	EA53AC/5□-CE	Blank, X, E, Y, P
	10	EA53AC/10□-CE	
	15	EA53AC/15□-CE	
	20	EA53AC/20□-CE	
	30	EA53AC/30□-CE	
	40	EA53AC/40□-CE	
	50	EA53AC/50□-CE	
	5	EA53C/5□-CE	Blank, X, E, Y, P
	10	EA53C/10□-CE	
	15	EA53C/15□-CE	
	20	EA53C/20□-CE	
	30	EA53C/30□-CE	
40	EA53C/40□-CE		
50	EA53C/50□-CE		
60	60	EA63C/60□-CE	Blank, X, E, Y, P
100	60	EA103AC/60-CE	Blank, X, E, Y, P
	75	EA103AC/75-CE	
100	100	EA103AC/100-CE	Blank, X, E, Y, P
	50	EA103C/50□-CE	
	60	EA103C/60□-CE	
	75	EA103C/75□-CE	
225	100	EA103C/100□-CE	Blank, X, E, P
	125	EA203C/125□-CE	
	150	EA203C/150□-CE	
	175	EA203C/175□-CE	
	200	EA203C/200□-CE	
400	225	EA203C/225□-CE	Blank, X, E, P
	250	EA403C/250□-CE	
	300	EA403C/300□-CE	
	350	EA403C/350□-CE	
600	400	EA403C/400□-CE	Blank, X, E, P, D
	500	EA603C/500□-CE	
800	600	EA603C/600□-CE	Blank, X, E, P, D
	700	EA803C/700□-CE	
800	800	EA803C/800□-CE	Blank, X, E, P, D

● E series, 4-pole

Breaker ampere frame	Rated current (A)	Type	□ : Available mounting and connection
100	50	EA104B/50□	Blank, X, E, Y
	60	EA104B/60□	
	75	EA104B/75□	
	100	EA104B/100□	

Molded Case Circuit Breakers

Type number

Line protection

● H series, 2-pole

Breaker ampere frame	Rated current (A)	Type	<input type="checkbox"/> : Available mounting and connection
50	15	H52BA/15 <input type="checkbox"/>	Blank, X, E, P
	20	H52BA/20 <input type="checkbox"/>	
	30	H52BA/30 <input type="checkbox"/>	
	40	H52BA/40 <input type="checkbox"/>	
	50	H52BA/50 <input type="checkbox"/>	
100	15	H102BA/15 <input type="checkbox"/>	Blank, X, E, P
	20	H102BA/20 <input type="checkbox"/>	
	30	H102BA/30 <input type="checkbox"/>	
	40	H102BA/40 <input type="checkbox"/>	
	50	H102BA/50 <input type="checkbox"/>	
	60	H102BA/60 <input type="checkbox"/>	
	75	H102BA/75 <input type="checkbox"/>	
100	H102BA/100 <input type="checkbox"/>		
225	125	H202BA/125 <input type="checkbox"/>	Blank, X, E, P
	150	H202BA/150 <input type="checkbox"/>	
	175	H202BA/175 <input type="checkbox"/>	
	200	H202BA/200 <input type="checkbox"/>	
	225	H202BA/225 <input type="checkbox"/>	
400	250	H402B/250 <input type="checkbox"/>	Blank, X, E, P
	300	H402B/300 <input type="checkbox"/>	
	350	H402B/350 <input type="checkbox"/>	
	400	H402B/400 <input type="checkbox"/>	

● L and H series, 3-pole

Breaker ampere frame	Rated current (A)	Type	<input type="checkbox"/> : Available mounting and connection		
50	5	LA53B/5	Blank		
	10	LA53B/10			
50	15	H53BA/15 <input type="checkbox"/>	Blank, X, E, P		
	20	H53BA/20 <input type="checkbox"/>			
	30	H53BA/30 <input type="checkbox"/>			
	40	H53BA/40 <input type="checkbox"/>			
	50	H53BA/50 <input type="checkbox"/>			
100	15	H103BA/15 <input type="checkbox"/>	Blank, X, E, P		
	20	H103BA/20 <input type="checkbox"/>			
	30	H103BA/30 <input type="checkbox"/>			
	40	H103BA/40 <input type="checkbox"/>			
	50	H103BA/50 <input type="checkbox"/>			
	60	H103BA/60 <input type="checkbox"/>			
	75	H103BA/75 <input type="checkbox"/>			
	100	H103BA/100 <input type="checkbox"/>			
	400	40		H103R/40 <input type="checkbox"/>	Blank, X, E, P
		50		H103R/50 <input type="checkbox"/>	
60		H103R/60 <input type="checkbox"/>			
75		H103R/75 <input type="checkbox"/>			
100		H103R/100 <input type="checkbox"/>			
225	125	H203BA/125 <input type="checkbox"/>	Blank, X, E, P		
	150	H203BA/150 <input type="checkbox"/>			
	175	H203BA/175 <input type="checkbox"/>			
	200	H203BA/200 <input type="checkbox"/>			
	225	H203BA/225 <input type="checkbox"/>			
400	125	H203R/125 <input type="checkbox"/>	Blank, X, E, P		
	150	H203R/150 <input type="checkbox"/>			
	175	H203R/175 <input type="checkbox"/>			
	200	H203R/200 <input type="checkbox"/>			
	225	H203R/225 <input type="checkbox"/>			
400	250	H403B/250 <input type="checkbox"/>	Blank, X, E, P		
	300	H403B/300 <input type="checkbox"/>			
	350	H403B/350 <input type="checkbox"/>			
	400	H403B/400 <input type="checkbox"/>			
	600	250	H403R/250 <input type="checkbox"/>	Blank, X, E, P	
		300	H403R/300 <input type="checkbox"/>		
		350	H403R/350 <input type="checkbox"/>		
		400	H403R/400 <input type="checkbox"/>		
600	500	H603B/500 <input type="checkbox"/>	Blank, X, E, P, D		
	600	H603B/600 <input type="checkbox"/>			
800	500	H603R/500 <input type="checkbox"/>	Blank, X, E, P, D		
	600	H603R/600 <input type="checkbox"/>			
800	700	H803B/700 <input type="checkbox"/>	Blank, X, E, P, D		
	800	H803B/800 <input type="checkbox"/>			
800	700	H803R/700 <input type="checkbox"/>	Blank, X, E, P, D		
	800	H803R/800 <input type="checkbox"/>			

■ S series, 2-pole IEC and CE marking conformed

Breaker ampere frame	Motor capacity (kW)		Rated current (A)	Type	□ : Available mounting and connection
	100V	200V			
30	—	—	2	SA32CM/2□-CE	Blank, X, E, Y, P Blank, X, E, Y, P Blank, X, E, Y, P Blank, X, E, Y, P Blank, X, E, Y, P Blank, X, E, Y, P
	—	—	4	SA32CM/4□-CE	
	0.1	0.4	5	SA32CM/5□-CE	
	0.2	0.75	8	SA32CM/8□-CE	
	0.4	—	10	SA32CM/10□-CE	
	0.75	—	16	SA32CM/16□-CE	

■ S series, 3-pole IEC and CE marking conformed

Breaker ampere frame	Motor capacity (kW)		Rated current (A)	Type	□ : Available mounting and connection	
	200 /220V	400 /440V				
30	—	0.2	0.7	SA33CM/0.7□-CE	Blank, X, E, Y, P	
	0.2	0.4	1.4	SA33CM/1.4□-CE		
	—	0.75	2	SA33CM/2□-CE		
	0.4	—	2.6	SA33CM/2.6□-CE		
	0.75	1.5	4	SA33CM/4□-CE		
	—	2.2	5	SA33CM/5□-CE		
	1.5	3.7	8	SA33CM/8□-CE		
	2.2	—	10	SA33CM/10□-CE		
	—	5.5	12	SA33CM/12□-CE		
	3.7	7.5	16	SA33CM/16□-CE		
	5.5	11	24	SA33CM/24□-CE		
	7.5	15	32	SA33CM/32□-CE		
50	—	0.2	0.7	SA53CM/0.7□-CE	Blank, X, E, Y, P	
	0.2	0.4	1.4	SA53CM/1.4□-CE		
	—	0.75	2	SA53CM/2□-CE		
	0.4	—	2.6	SA53CM/2.6□-CE		
	0.75	1.5	4	SA53CM/4□-CE		
	—	2.2	5	SA53CM/5□-CE		
	1.5	3.7	8	SA53CM/8□-CE		
	2.2	—	10	SA53CM/10□-CE		
	—	5.5	12	SA53CM/12□-CE		
	3.7	7.5	16	SA53CM/16□-CE		
	5.5	11	24	SA53CM/24□-CE		
	7.5	15	32	SA53CM/32□-CE		
	—	18.5	40	SA53CM/40□-CE		
	11	22	45	SA53CM/45□-CE		
	2.2	—	10	SA53RCM/10□-CE		Blank, X, E, Y, P
	—	5.5	12	SA53RCM/12□-CE		
	3.7	7.5	16	SA53RCM/16□-CE		
	5.5	11	24	SA53RCM/24□-CE		
7.5	15	32	SA53RCM/32□-CE			
—	18.5	40	SA53RCM/40□-CE			
11	22	45	SA53RCM/45□-CE			
60	15	30	60	SA63CM/60□-CE	Blank, X, E, Y, P	
100	3.7	7.5	16	SA103CM/16□-CE	Blank, X, E, P	
	5.5	11	24	SA103CM/24□-CE		
	7.5	15	32	SA103CM/32□-CE		
	—	18.5	40	SA103CM/40□-CE		
	11	22	45	SA103CM/45□-CE		
	15	30	60	SA103CM/60□-CE		
	18.5	37	75	SA103CM/75□-CE		
	22	45	90	SA103CM/90□-CE		

Molded Case Circuit Breakers

Type number

Motor protection

■ S series, 3-pole IEC and CE marking conformed

Breaker ampere frame	Motor capacity (kW)		Rated current (A)	Type	☐ : Available mounting and connection
	200/ 220V	400/ 440V			
100	3.7	7.5	16	SA103RCM/16☐-CE	Blank, X, E, P
	5.5	11	24	SA103RCM/24☐-CE	
	7.5	15	32	SA103RCM/32☐-CE	
	—	18.5	40	SA103RCM/40☐-CE	
	11	22	45	SA103RCM/45☐-CE	
	15	30	60	SA103RCM/60☐-CE	
	18.5	37	75	SA103RCM/75☐-CE	
	22	45	90	SA103RCM/90☐-CE	
225	30	55	125	SA203CM/125☐-CE	Blank, X, E, P
	37	75	150	SA203CM/150☐-CE	
	45	90	175	SA203CM/175☐-CE	
	—	—	200	SA203CM/200☐-CE	
	55	110	225	SA203CM/225☐-CE	
225	30	55	125	SA203RCM/125☐-CE	Blank, X, E, P
	37	75	150	SA203RCM/150☐-CE	
	45	90	175	SA203RCM/175☐-CE	
	—	—	200	SA203RCM/200☐-CE	
	55	110	225	SA203RCM/225☐-CE	

■ E series, 3-pole IEC and CE marking conformed

30	0.2	—	1.4	EA33ACM/1.4☐-CE	Blank, X, E, Y, P
	0.4	—	2.6	EA33ACM/2.6☐-CE	
	0.75	—	4	EA33ACM/4☐-CE	
	1.5	—	8	EA33ACM/8☐-CE	
	2.2	—	10	EA33ACM/10☐-CE	
	3.7	—	16	EA33ACM/16☐-CE	
	5.5	—	24	EA33ACM/24☐-CE	
	7.5	—	32	EA33ACM/32☐-CE	
50	5.5	11	24	EA53CM/24☐-CE	Blank, X, E, Y, P
	7.5	15	32	EA53CM/32☐-CE	
	—	18.5	40	EA53CM/40☐-CE	
	11	22	45	EA53CM/45☐-CE	
60	15	30	60	EA63CM/60☐-CE	Blank, X, E, Y, P
100	15	30	60	EA103CM/60☐-CE	Blank, X, E, Y, P
	18.5	37	75	EA103CM/75☐-CE	
	22	45	90	EA103CM/90☐-CE	
225	30	55	125	EA203CM/125☐-CE	Blank, X, E, P
	37	75	150	EA203CM/150☐-CE	
	45	90	175	EA203CM/175☐-CE	
	—	—	200	EA203CM/200☐-CE	
	55	110	225	EA203CM/225☐-CE	

■ L and H series, 3-pole

50	—	2.2	5	LA53BM/5	Blank
	1.5	3.7	8	LA53BM/8	
	2.2	—	10	LA53BM/10	
	—	5.5	12	LA53BM/12	
50	3.7	7.5	16	H53BAM/16☐	Blank, X, E, P
	5.5	11	24	H53BAM/24☐	
	7.5	15	32	H53BAM/32☐	
	—	18.5	40	H53BAM/40☐	
	11	22	45	H53BAM/45☐	

■ UL489 Listed

● S and E series, 2-pole

Breaker ampere frame	Rated current (A)	Type	☐ : Available terminal combination	
50	3	SA52RCUL/3☐	Blank, L1, L3, L4	
	5	SA52RCUL/5☐		
	10	SA52RCUL/10☐		
	15	SA52RCUL/15☐		
	20	SA52RCUL/20☐		
	30	SA52RCUL/30☐		
100	40	SA52RCUL/40☐	Blank, L, L1, L3, L4, L5, L6, L7, L8	
	50	SA52RCUL/50☐		
	60	SA102CUL/60☐		
	70	SA102CUL/70☐		
	75	SA102CUL/75☐		
	80	SA102CUL/80☐		
	90	SA102CUL/90☐		
	100	SA102CUL/100☐		
	15	SA102RCUL/15☐		Blank, L, L1, L3, L4, L5, L6, L7, L8
	20	SA102RCUL/20☐		
	30	SA102RCUL/30☐		
	40	SA102RCUL/40☐		
50	SA102RCUL/50☐			
60	SA102RCUL/60☐			
70	SA102RCUL/70☐			
75	SA102RCUL/75☐			
80	SA102RCUL/80☐			
90	SA102RCUL/90☐			
100	SA102RCUL/100☐			
225	125	SA202CUL/125☐	Blank, L, L1, L3, L4, L5, L6, L7, L8	
	150	SA202CUL/150☐		
	175	SA202CUL/175☐		
	200	SA202CUL/200☐		
	225	SA202CUL/225☐		
	125	SA202RCUL/125☐		Blank, L, L1, L3, L4, L5, L6, L7, L8
150	SA202RCUL/150☐			
175	SA202RCUL/175☐			
200	SA202RCUL/200☐			
225	SA202RCUL/225☐			
400	250	SA402CUL/250☐	L, L1, L7, L8	
	300	SA402CUL/300☐		
	350	SA402CUL/350☐		
	400	SA402CUL/400☐		
	250	SA402RCUL/250☐		L, L1, L7, L8
	300	SA402RCUL/300☐		
350	SA402RCUL/350☐			
400	SA402RCUL/400☐			
100	60	EA102CUL/60☐	Blank, L1, L3, L4	
	70	EA102CUL/70☐		
	75	EA102CUL/75☐		
	80	EA102CUL/80☐		
	90	EA102CUL/90☐		
	100	EA102CUL/100☐		

● S and E series, 3-pole

Breaker ampere frame	Rated current (A)	Type	☐ : Available terminal combination	
50	3	SA53RCUL/3☐	Blank, L1, L3, L4	
	5	SA53RCUL/5☐		
	10	SA53RCUL/10☐		
	15	SA53RCUL/15☐		
	20	SA53RCUL/20☐		
	30	SA53RCUL/30☐		
100	40	SA53RCUL/40☐	Blank, L, L1, L3, L4, L5, L6, L7, L8	
	50	SA53RCUL/50☐		
	60	SA103CUL/60☐		
	70	SA103CUL/70☐		
	75	SA103CUL/75☐		
	80	SA103CUL/80☐		
	90	SA103CUL/90☐		
	100	SA103CUL/100☐		
	15	SA103RCUL/15☐		Blank, L, L1, L3, L4, L5, L6, L7, L8
	20	SA103RCUL/20☐		
	30	SA103RCUL/30☐		
	40	SA103RCUL/40☐		
50	SA103RCUL/50☐			
60	SA103RCUL/60☐			
70	SA103RCUL/70☐			
75	SA103RCUL/75☐			
80	SA103RCUL/80☐			
90	SA103RCUL/90☐			
100	SA103RCUL/100☐			
225	125	SA203CUL/125☐	Blank, L, L1, L3, L4, L5, L6, L7, L8	
	150	SA203CUL/150☐		
	175	SA203CUL/175☐		
	200	SA203CUL/200☐		
	225	SA203CUL/225☐		
	125	SA203RCUL/125☐		Blank, L, L1, L3, L4, L5, L6, L7, L8
150	SA203RCUL/150☐			
175	SA203RCUL/175☐			
200	SA203RCUL/200☐			
225	SA203RCUL/225☐			
400	250	SA403CUL/250☐	L, L1, L7, L8	
	300	SA403CUL/300☐		
	350	SA403CUL/350☐		
	400	SA403CUL/400☐		
	250	SA403RCUL/250☐		L, L1, L7, L8
	300	SA403RCUL/300☐		
350	SA403RCUL/350☐			
400	SA403RCUL/400☐			
600	500	SA603RCUL/500☐	L, L1, L7, L8	
	600	SA603RCUL/600☐		
800	700	SA803RCUL/700☐	L, L1, L7, L8	
	800	SA803RCUL/800☐		L
100	60	EA103CUL/60☐	Blank, L1, L3, L4	
	70	EA103CUL/70☐		
	75	EA103CUL/75☐		
	80	EA103CUL/80☐		
	90	EA103CUL/90☐		
	100	EA103CUL/100☐		

Molded Case Circuit Breakers

Dimensions

S series/2, 3-pole

■ Dimensions, mm

● Front mounting, front connection

SA32C □ -CE, 52C □ -CE, 52RC □ -CE

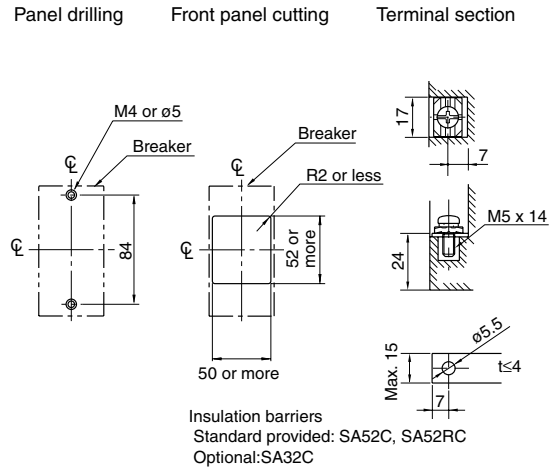
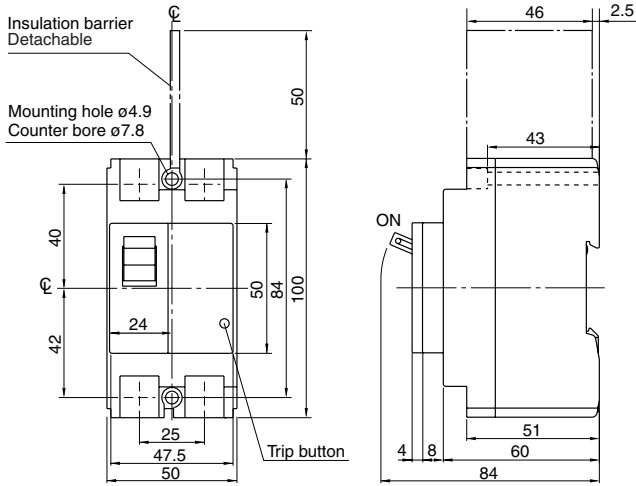

SA33C □ -CE, 53C □ -CE, 53RC □ -CE

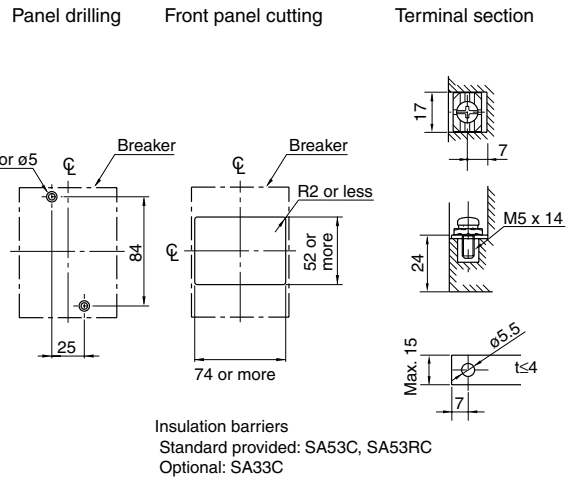
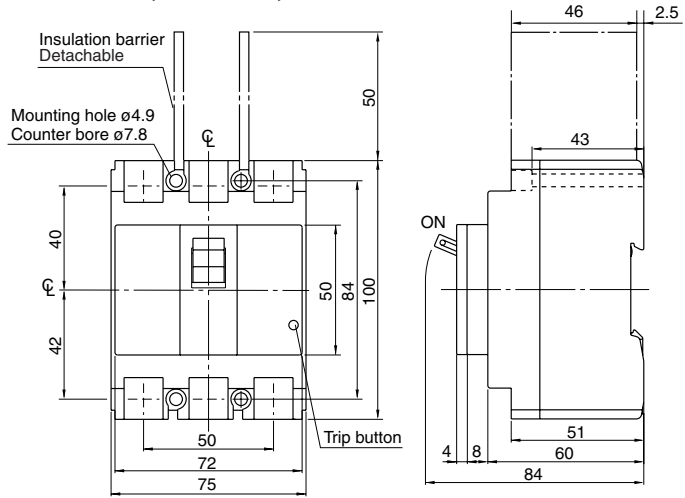

SA62C □ -CE, 62RC □ -CE

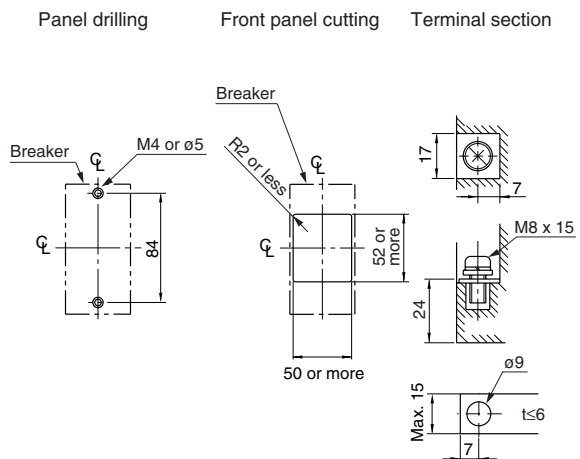
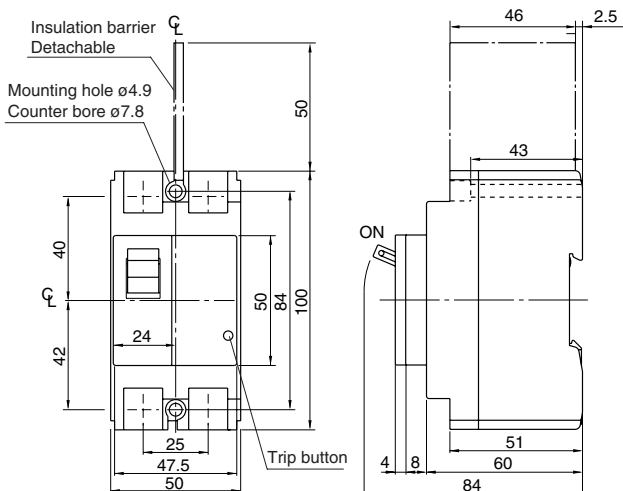

Molded Case Circuit Breakers

Dimensions

S series/2, 3-pole

■ Dimensions, mm

● Front mounting, front connection

SA63C □ -CE, 63RC □ -CE

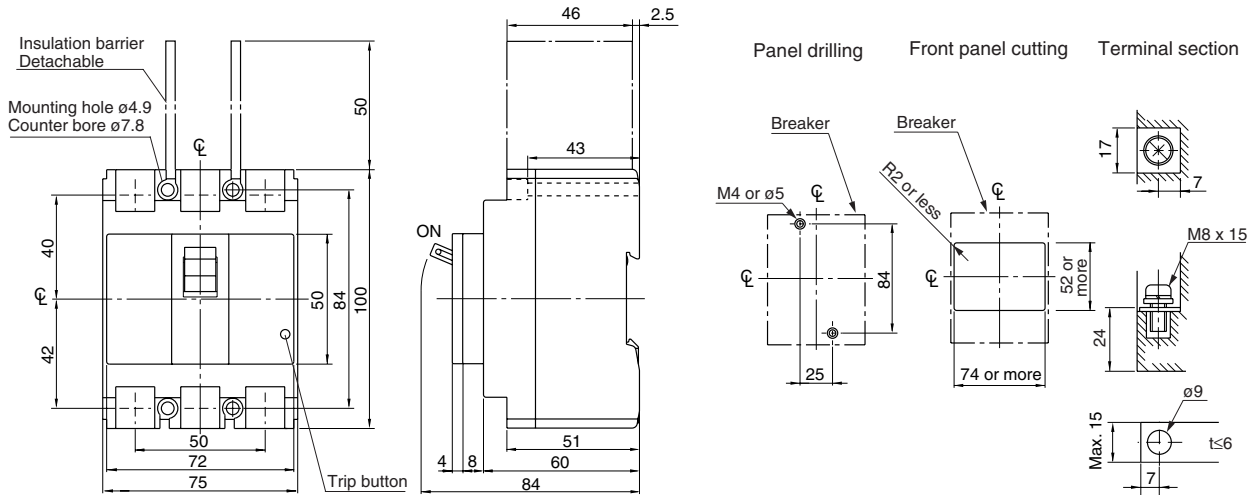

SA102C □ -CE

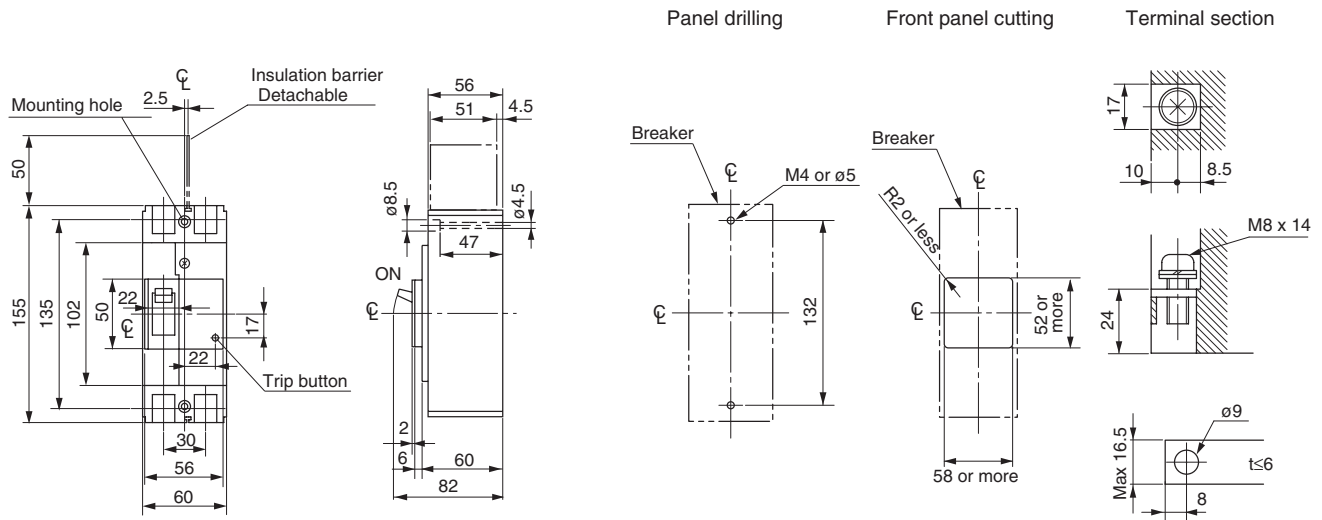

SA103C □ -CE

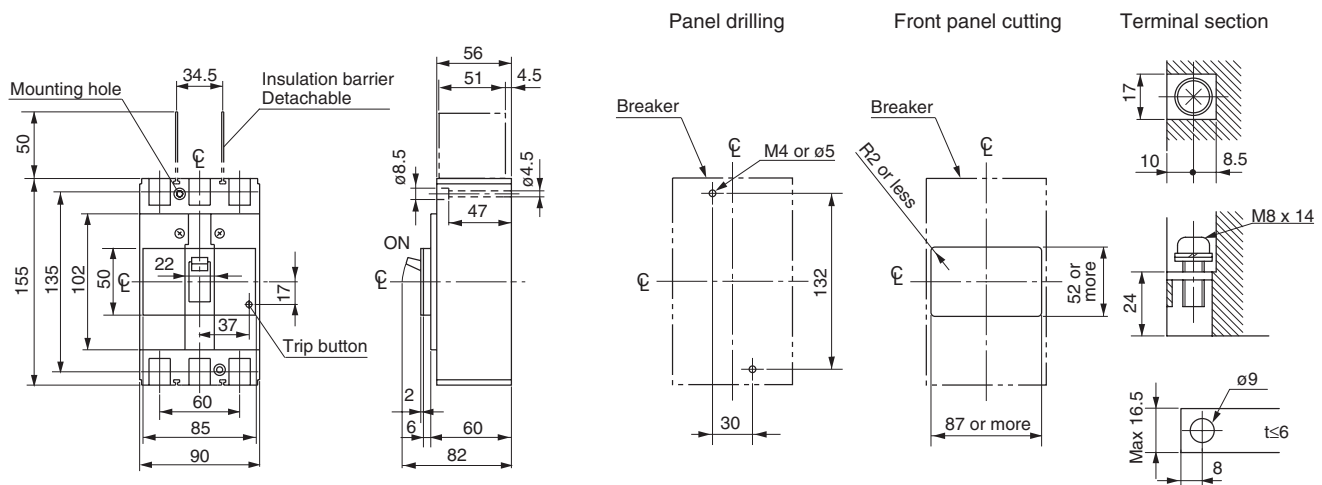

Molded Case Circuit Breakers

Dimensions

S series/2, 3-pole

■ Dimensions, mm

● Front mounting, front connection

SA102RC □ -CE, 103RC □ -CE

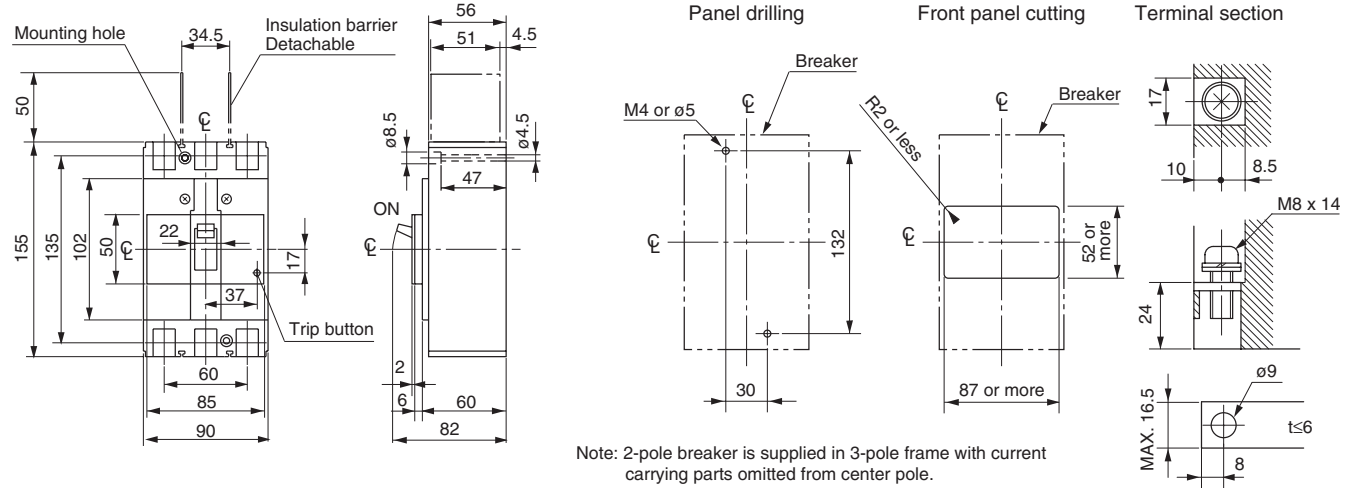

SA202C □ -CE, 203C □ -CE, 202RC □ -CE, 203RC □ -CE

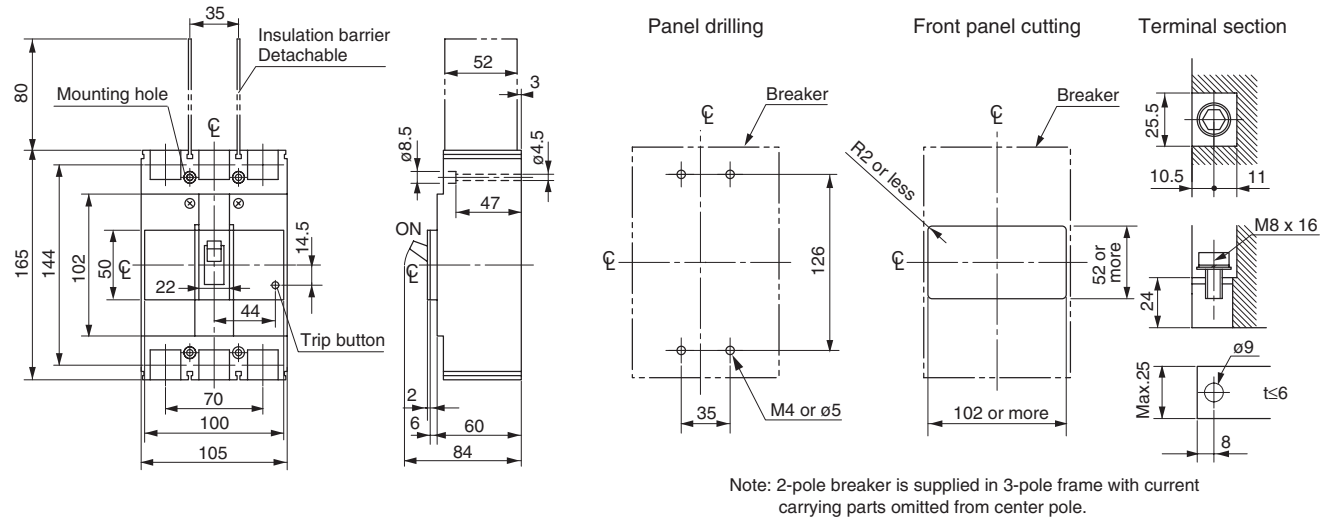

SA402C □ -CE, 403C □ -CE, 402RC □ -CE, 403RC □ -CE

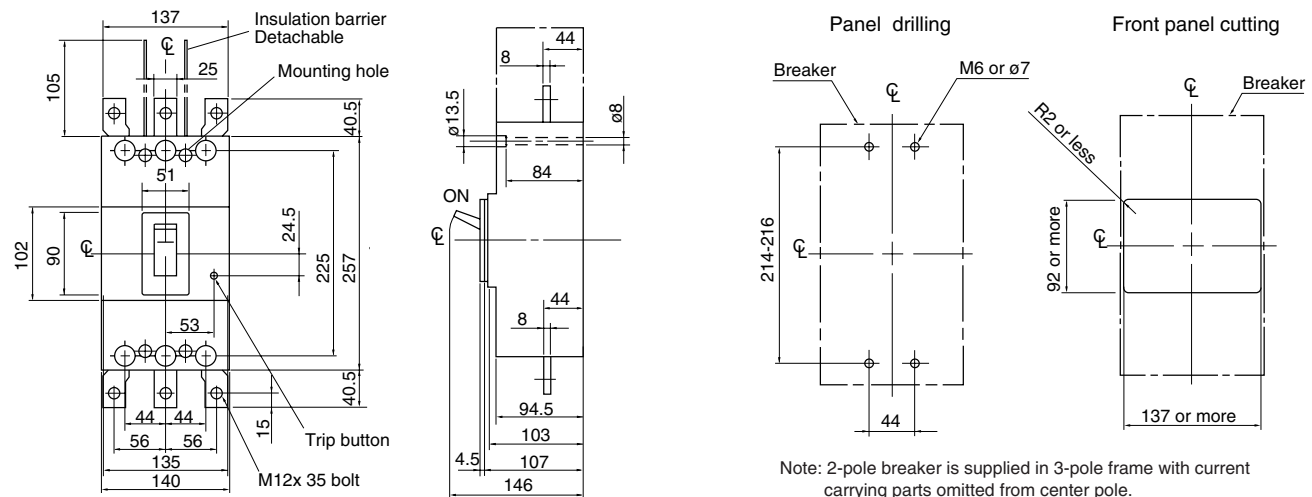

Molded Case Circuit Breakers

Dimensions

S series/3, 4-pole

■ Dimensions, mm

● Front mounting, front connection

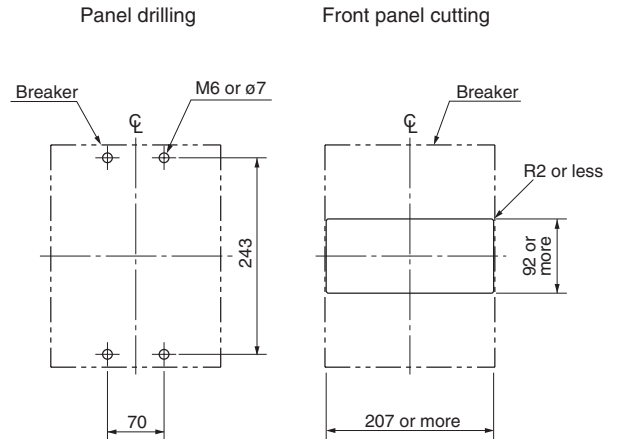
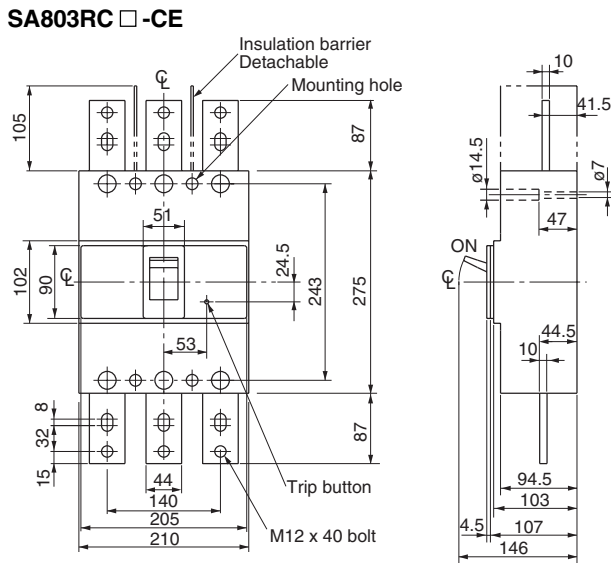
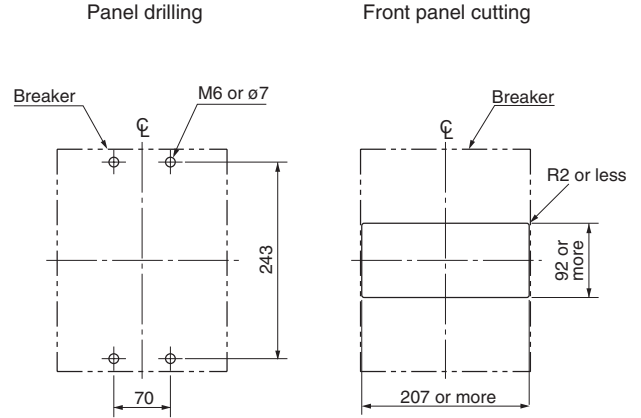
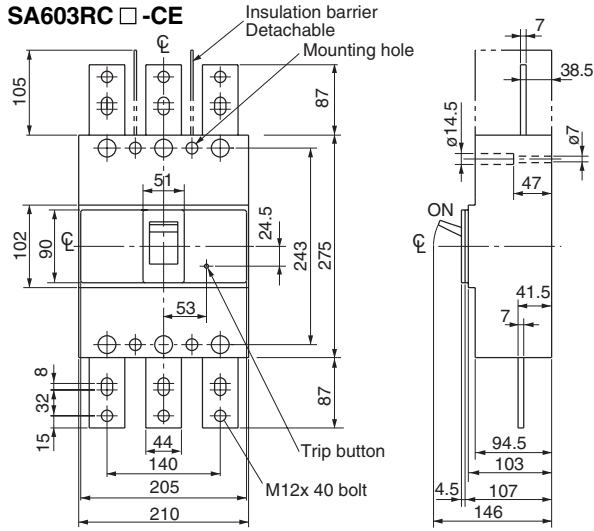

SA1003E, SA1004E, SA1203E, SA1204E

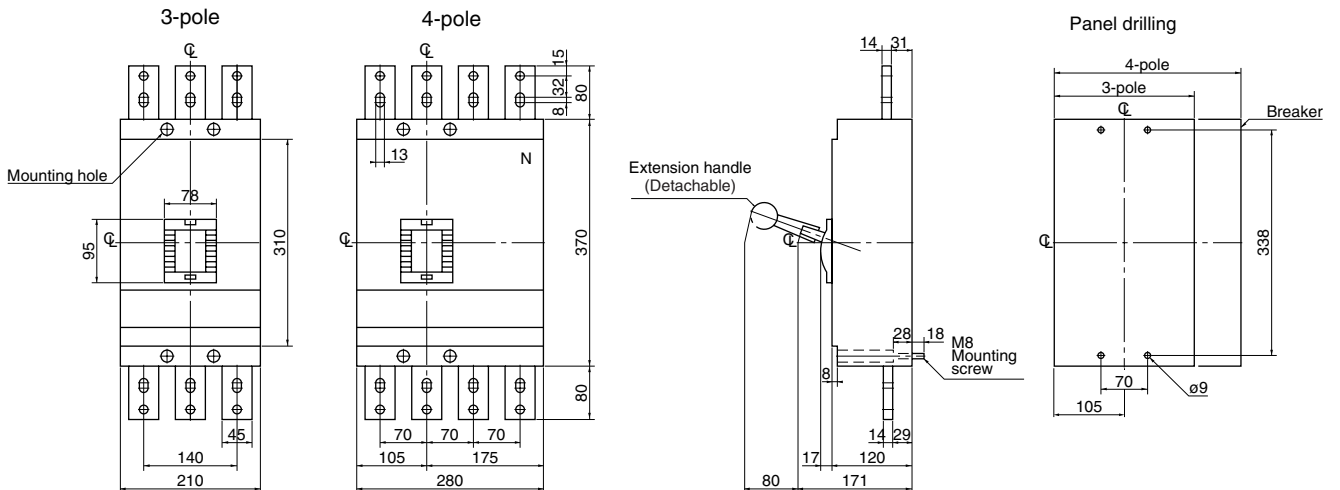

Molded Case Circuit Breakers

Dimensions

S series/3, 4-pole

■ Dimensions, mm

● Front mounting, front connection

SA1603E, SA1604E

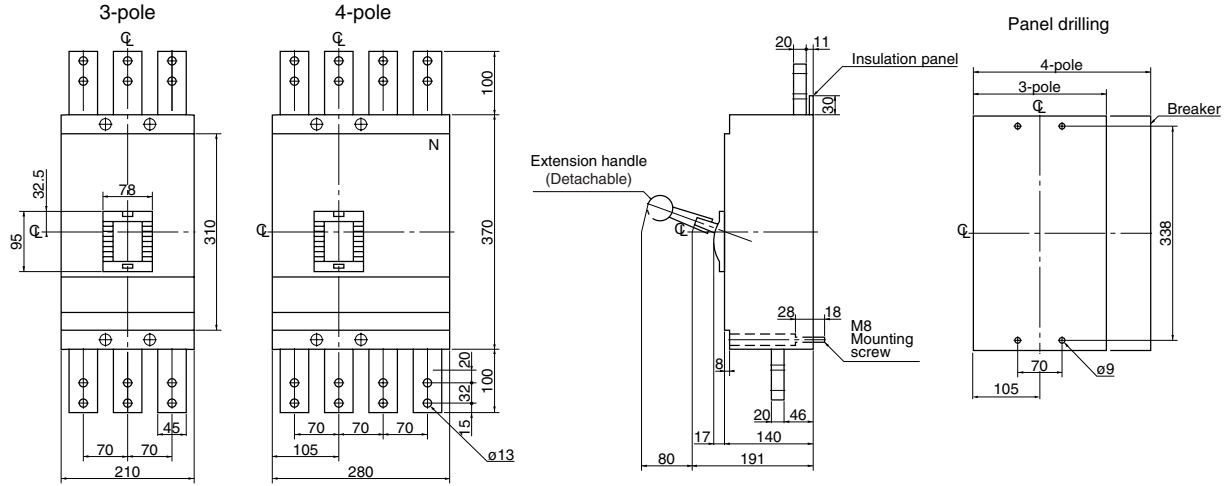

SA54B

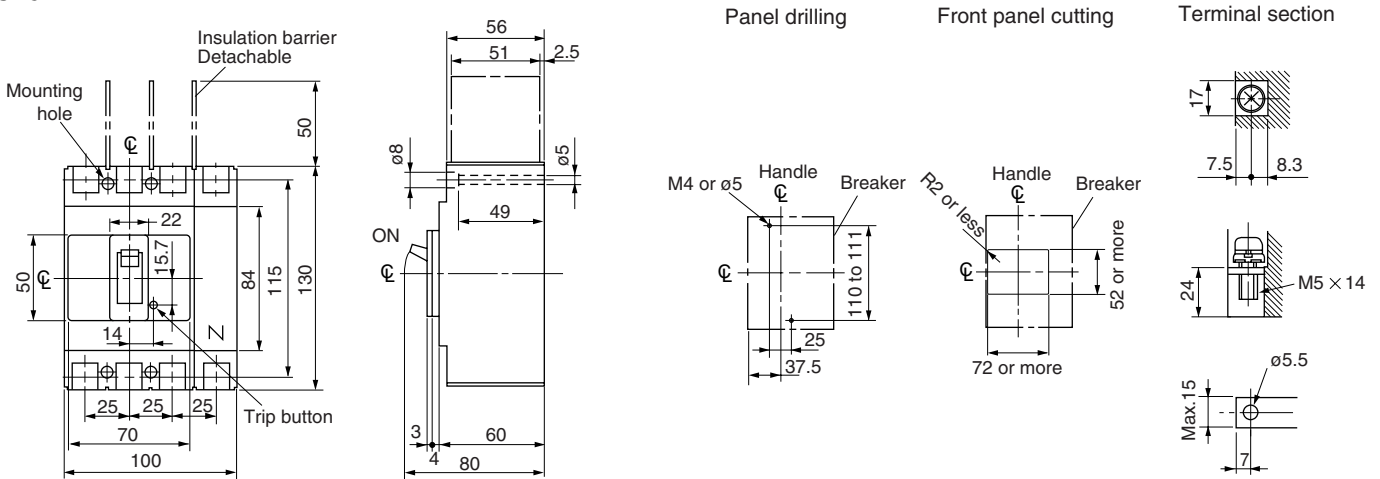

SA104R

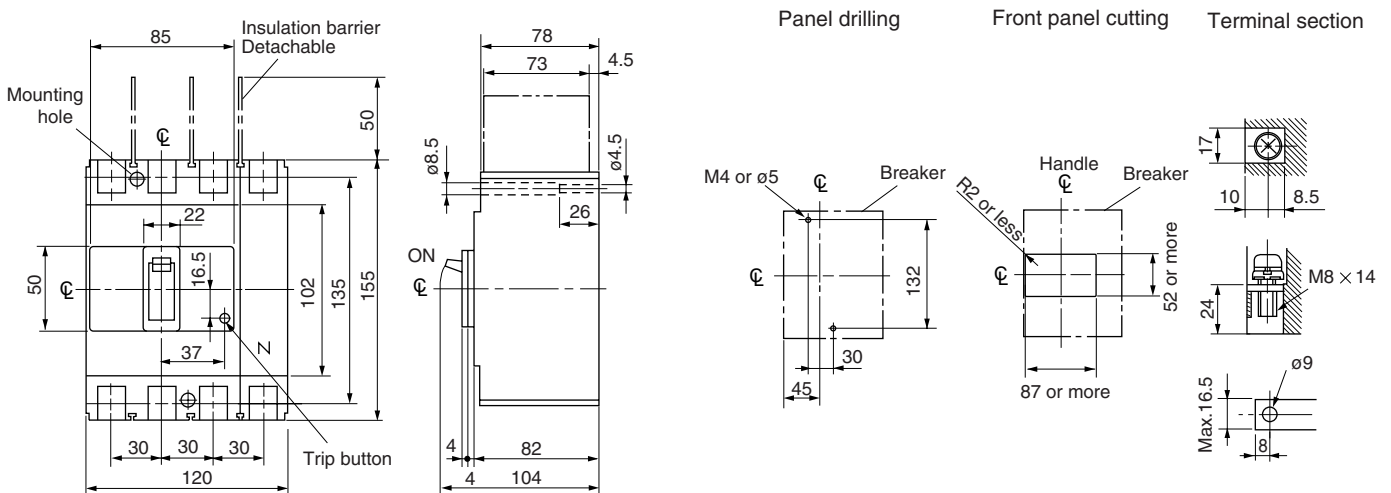

Molded Case Circuit Breakers

Dimensions

S series/4-pole

■ Dimensions, mm

● Front mounting, front connection

SA204R

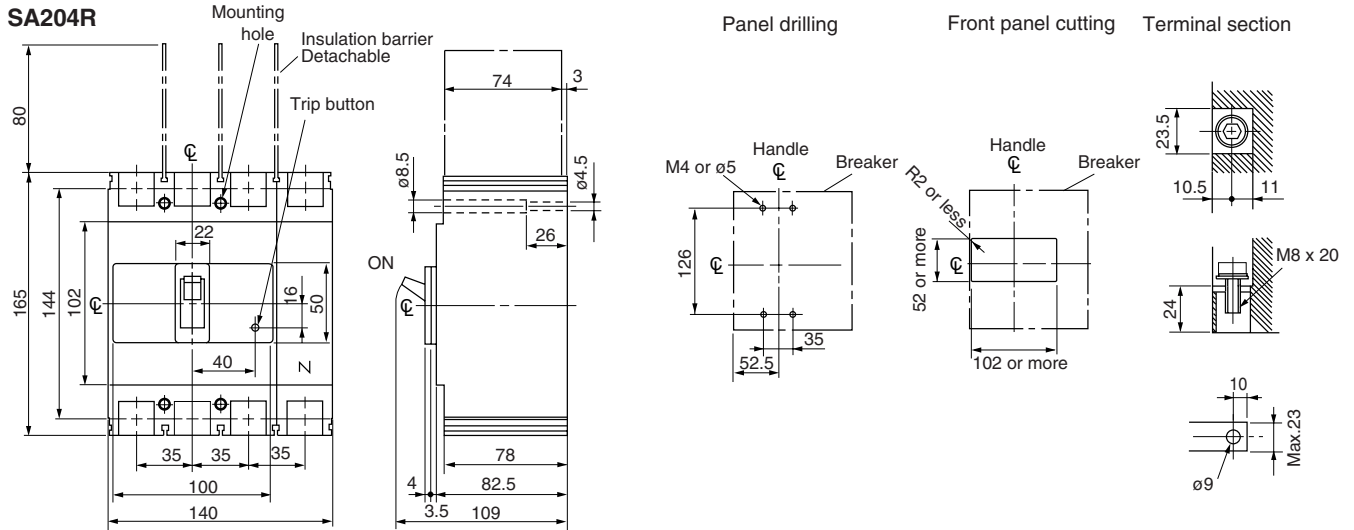

SA404HA

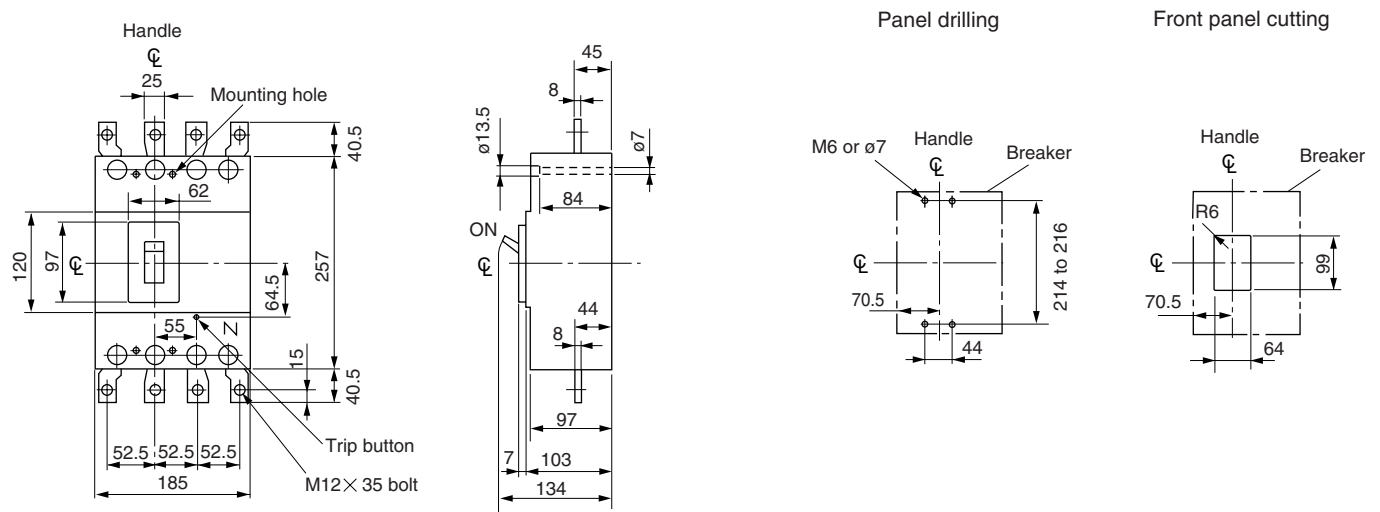

SA604H, 804H

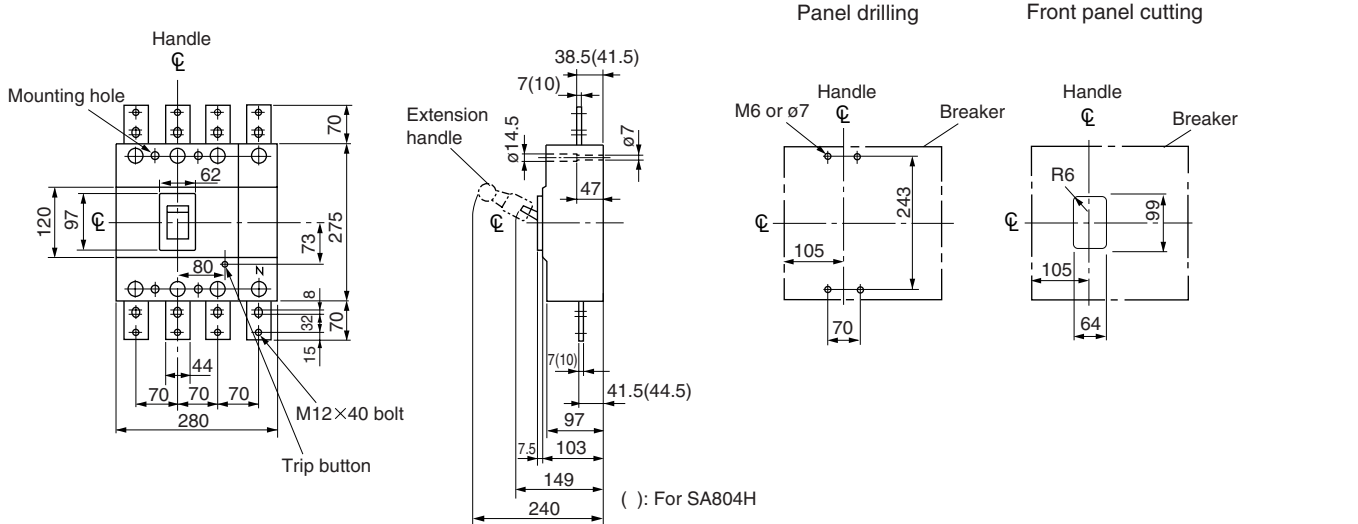

Molded Case Circuit Breakers

Dimensions

S series/2, 3-pole

■ Dimensions, mm

● Front mounting, rear connection (type X)

SA32C □ -CE, 52C □ -CE, 52RC □ -CE

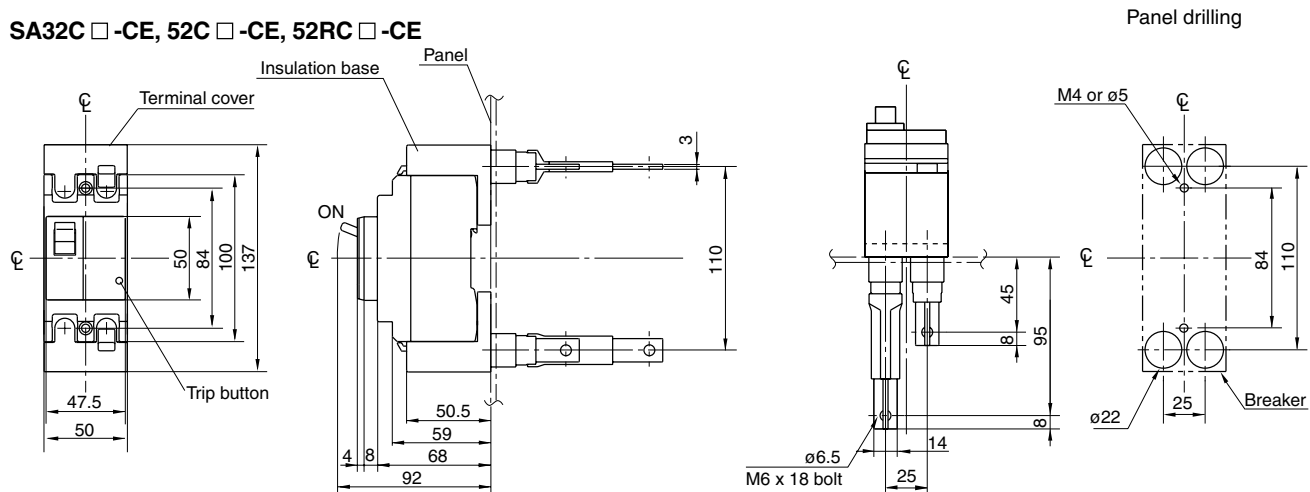

SA33C □ -CE, 53C □ -CE, 53RC □ -CE

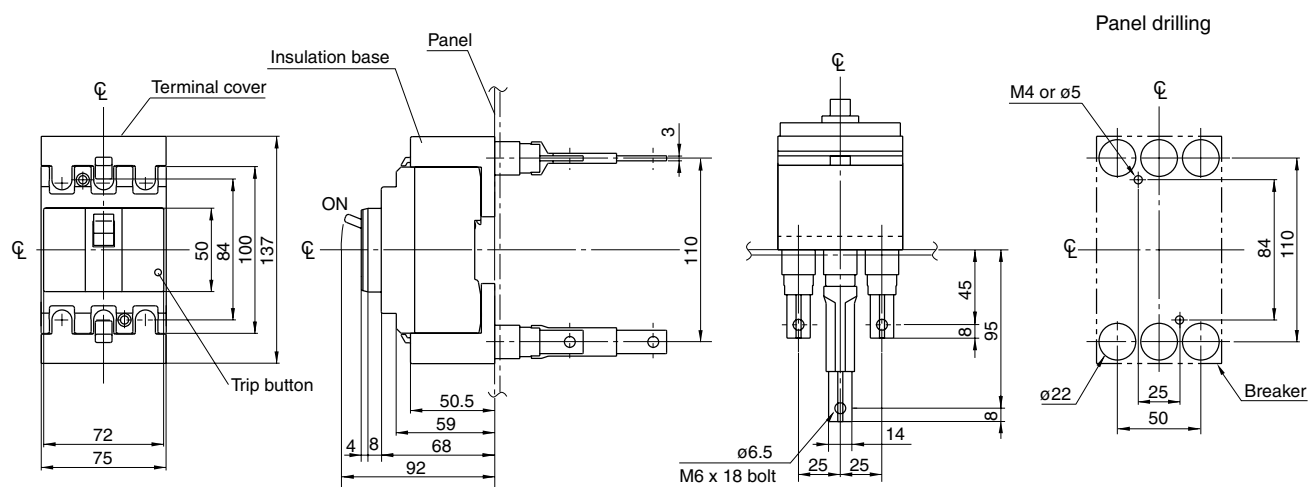

Molded Case Circuit Breakers

Dimensions

S series/2, 3-pole

- Dimensions, mm
- Front mounting, rear connection (type X)

SA62C □ -CE, 62RC □ -CE

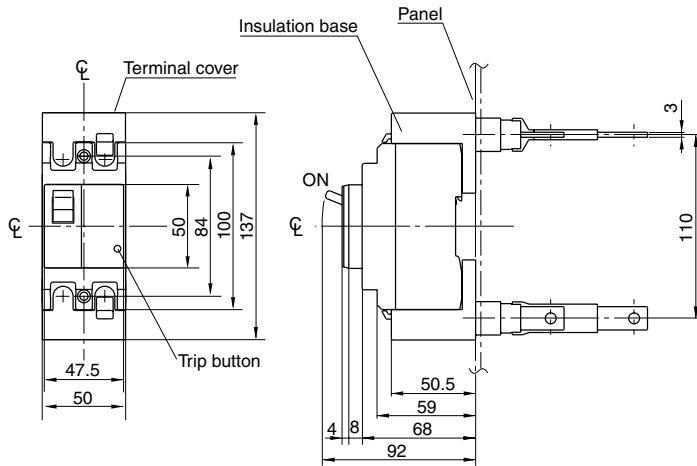

Panel drilling

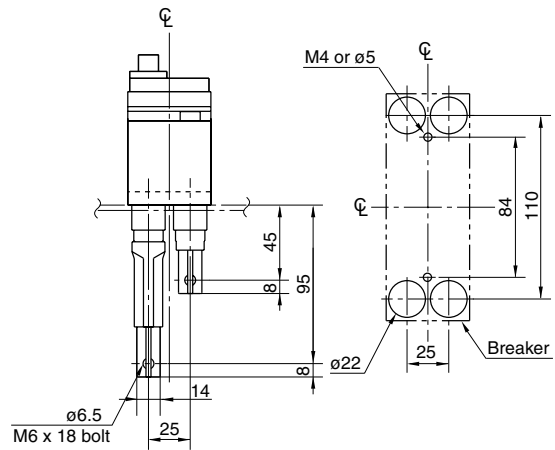

SA63C □ -CE, 63RC □ -CE

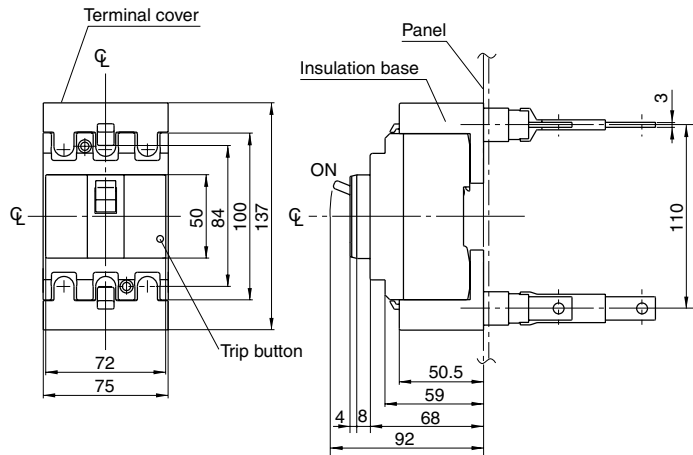

Panel drilling

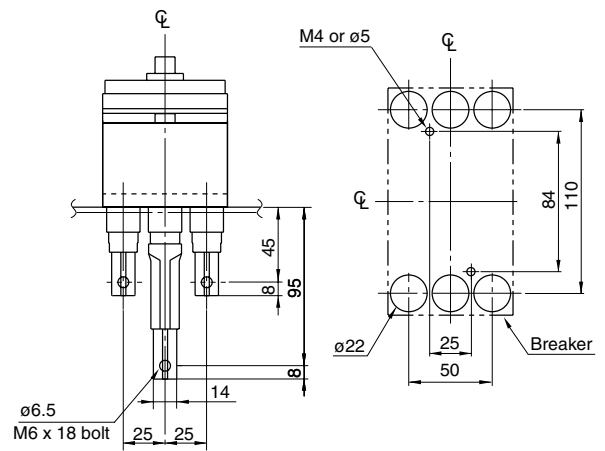

SA102C □ -CE

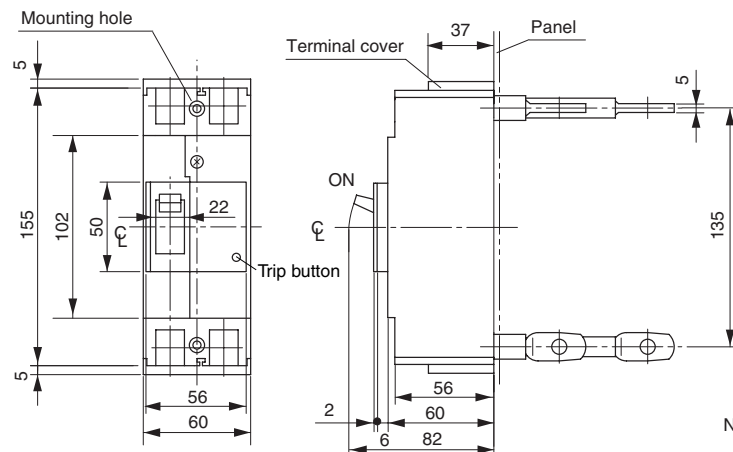

Panel drilling

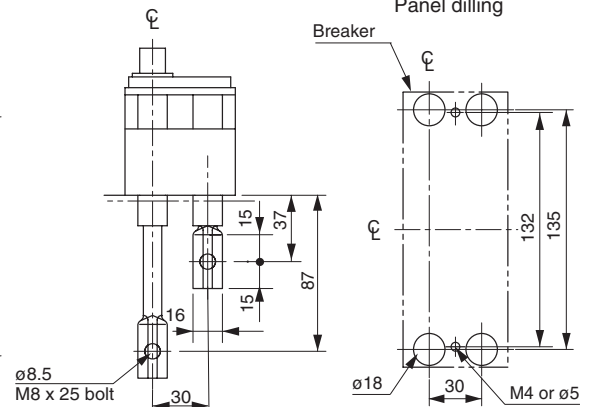

Note: At shipment, studs are mounted on the MCCB unit as shown in the figure for side view.

•Studs for line side terminal : Mounted horizontally.

•Studs for load-side terminal : Mounted vertically.

Each stud can be turned by 90°.

Molded Case Circuit Breakers

Dimensions

S series/2, 3-pole

■ Dimensions, mm

● Front mounting, rear connection (type X)

SA103C □ -CE

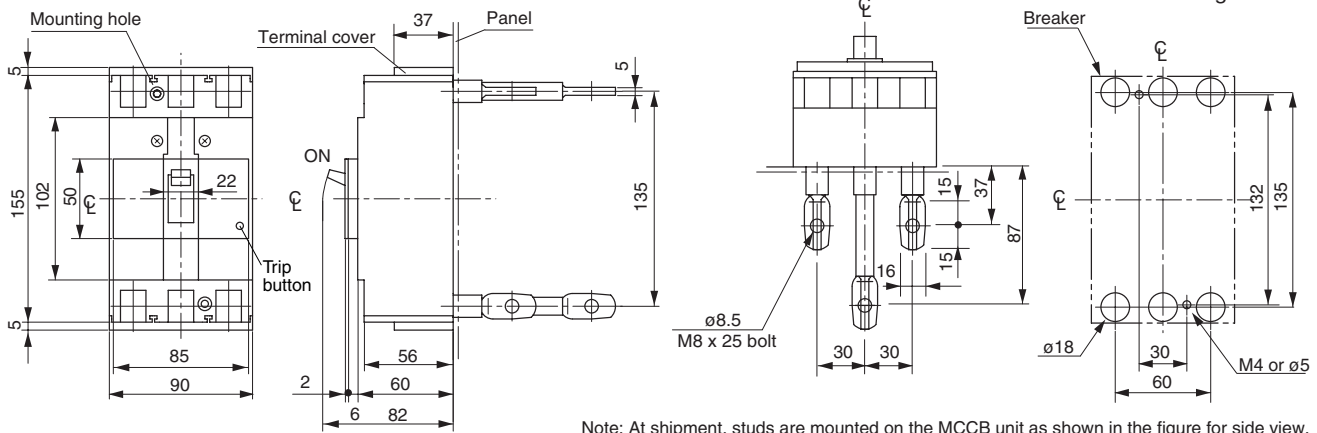

Note: At shipment, studs are mounted on the MCCB unit as shown in the figure for side view.

•Studs for line side terminal : Mounted horizontally.

•Studs for load-side terminal : Mounted vertically.

Each stud can be turned by 90°.

SA102RC □ -CE, 103RC □ -CE

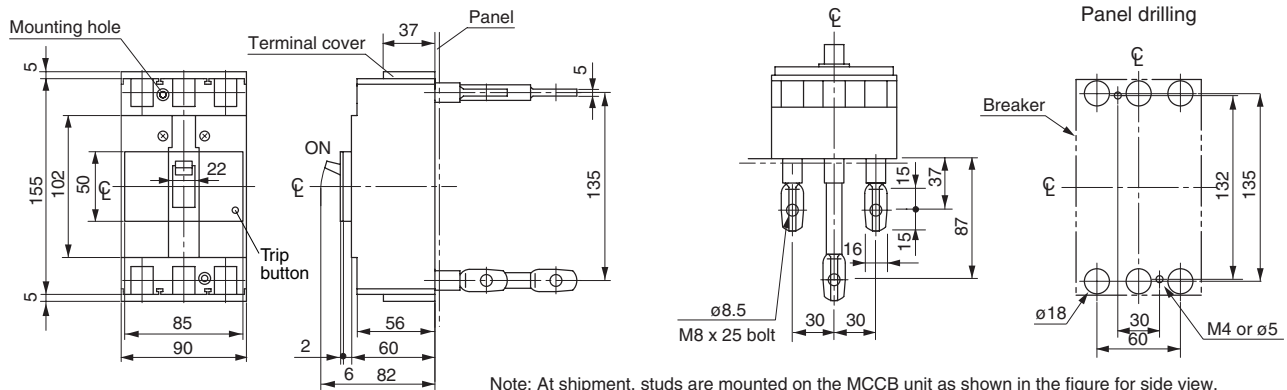

Note: At shipment, studs are mounted on the MCCB unit as shown in the figure for side view.

•Studs for line side terminal : Mounted horizontally.

•Studs for load-side terminal : Mounted vertically.

Each stud can be turned by 90°.

2-pole breaker is supplied in 3-pole frame with current carrying parts omitted from center pole.

SA202C □ -CE, 203C □ -CE, 202RC □ -CE, 203RC □ -CE

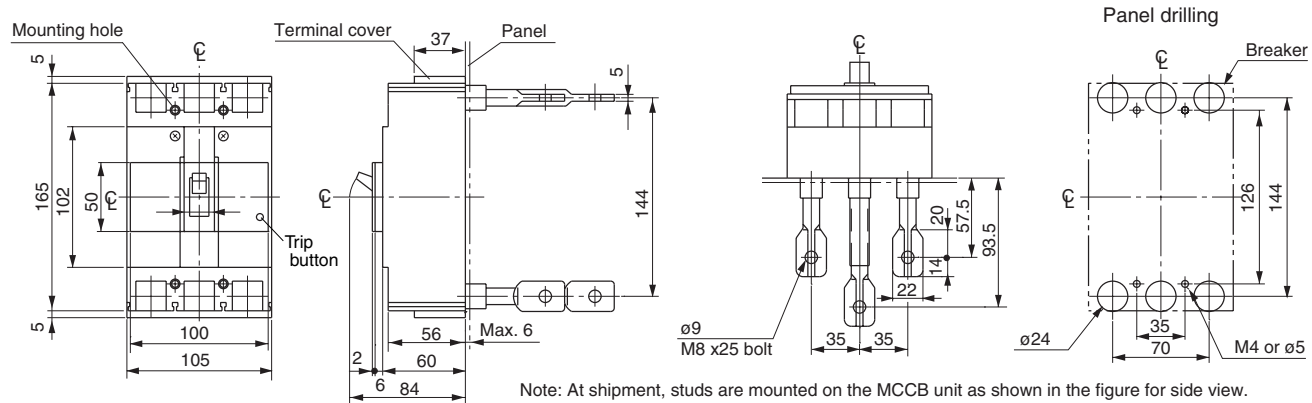

Note: At shipment, studs are mounted on the MCCB unit as shown in the figure for side view.

•Studs for line side terminal : Mounted horizontally.

•Studs for load-side terminal : Mounted vertically.

Each stud can be turned by 90°.

2-pole breaker is supplied in 3-pole frame with current carrying parts omitted from center pole.

Molded Case Circuit Breakers Dimensions S series/2, 3-pole

■ Dimensions, mm

● Front mounting, rear connection (type X)

SA402C □ -CE, 403C □ -CE, 402RC □ -CE, 403RC □ -CE

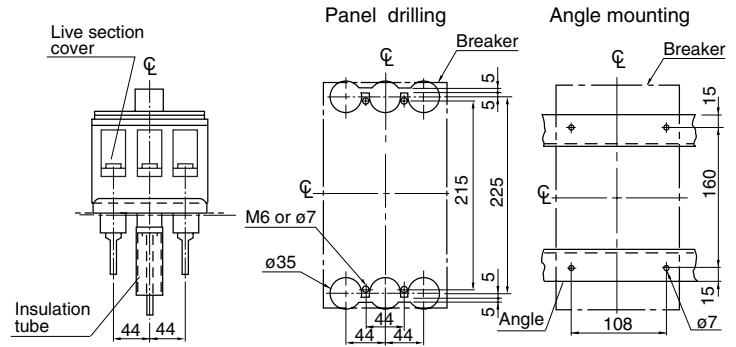
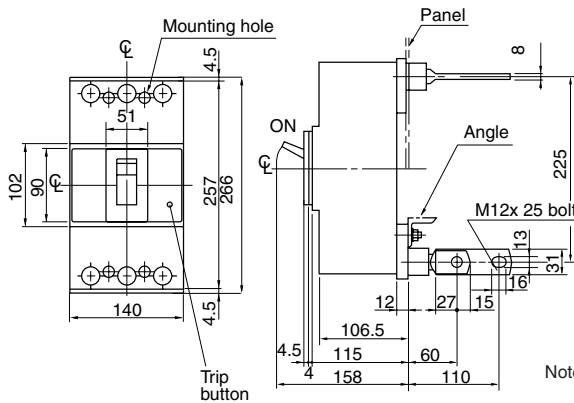

Note: At shipment, studs are mounted on the MCCB unit as shown in the figure for side view.
 •Studs for line side terminal : Mounted horizontally.
 •Studs for load-side terminal : Mounted vertically.
 Each stud can be turned by 90°.
 2-pole breaker is supplied in 3-pole frame with current carrying parts omitted from center pole.

SA603RC □ -CE

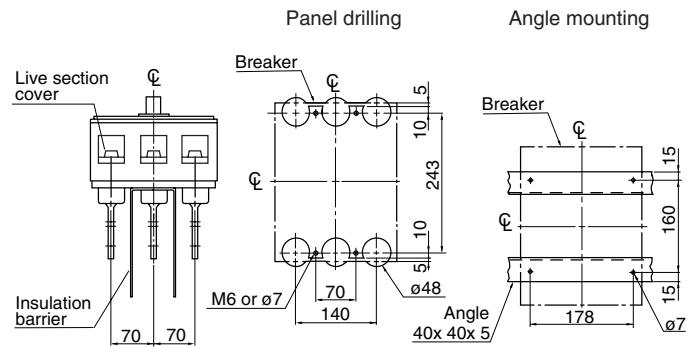
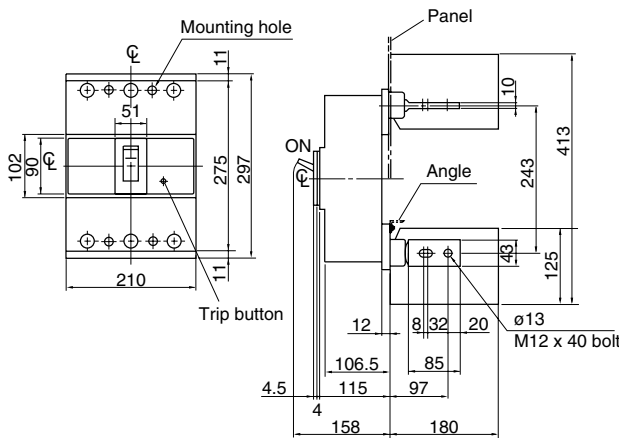

Note: At shipment, studs are mounted on the MCCB unit as shown in the figure for side view.
 •Studs for line side terminal : Mounted horizontally.
 •Studs for load side terminal : Mounted vertically.
 Each stud can be turned by 90°.

SA803RC □ -CE

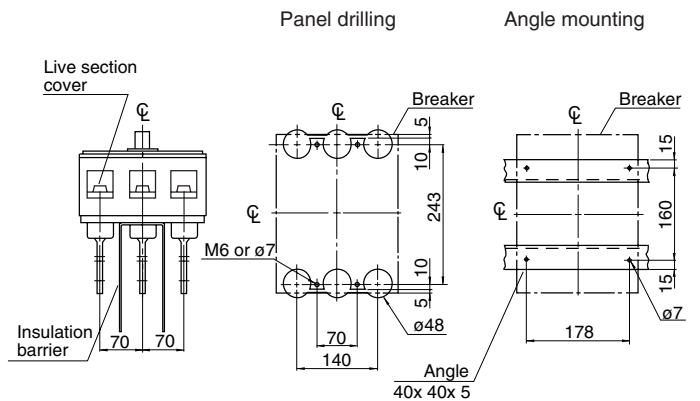
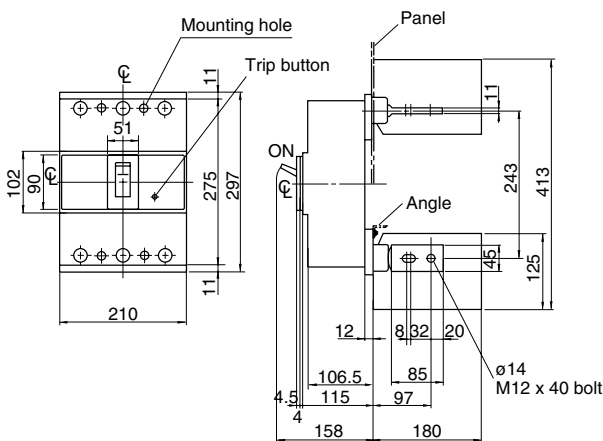

Note: At shipment, studs are mounted on the MCCB unit as shown in the figure for side view.
 •Studs for line side terminal : Mounted horizontally.
 •Studs for load side terminal : Mounted vertically.
 Each stud can be turned by 90°.

Molded Case Circuit Breakers

Dimensions

S series/ 3-pole

■ Dimensions, mm

● Front mounting, rear connection (type X)

SA1003E, SA1004E, SA1203E, SA1204E

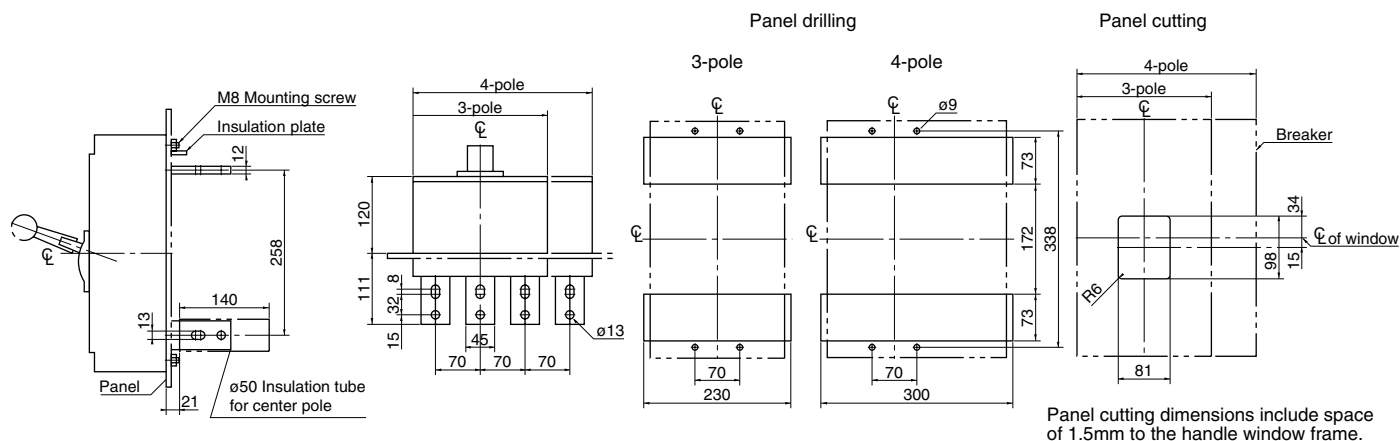

SA1603E, SA1604E

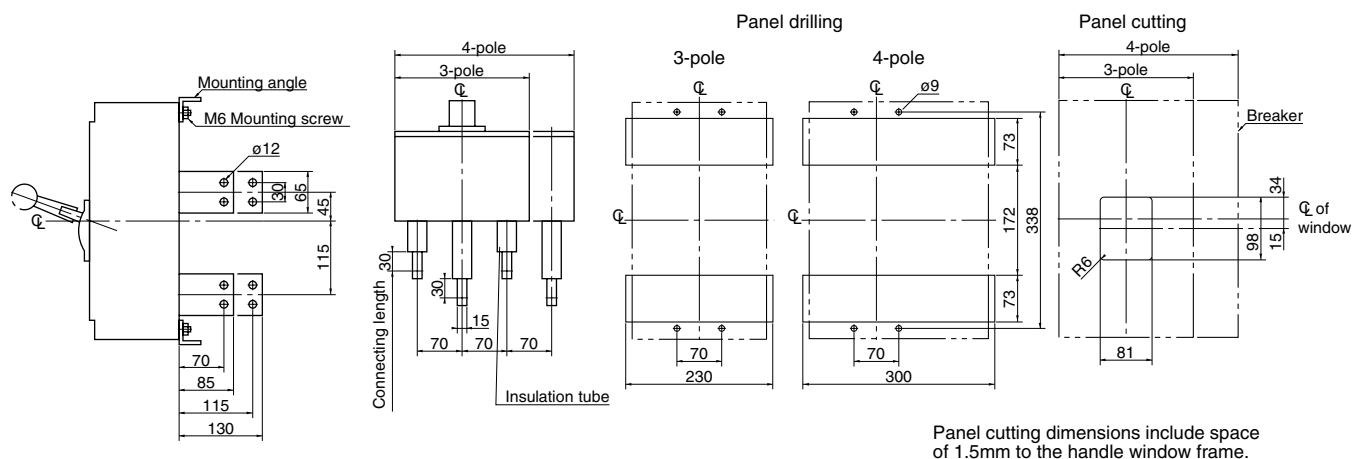

Dimensions for reference only. Confirm before construction begins.

Molded Case Circuit Breakers

Dimensions

E series/2, 3-pole

- Dimensions, mm
- Front mounting, front connection

EA32AC □ -CE, 52AC □ -CE, 52C □ -CE

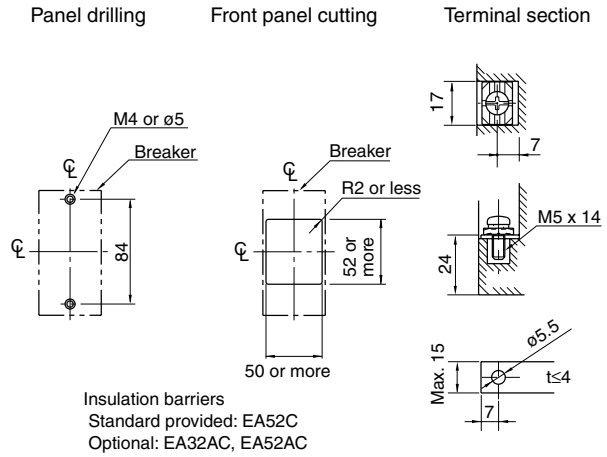
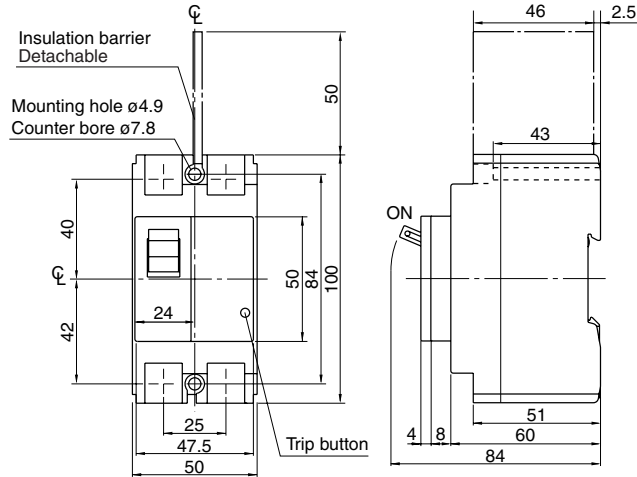

EA33AC □ -CE, 53AC □ -CE, 53C □ -CE

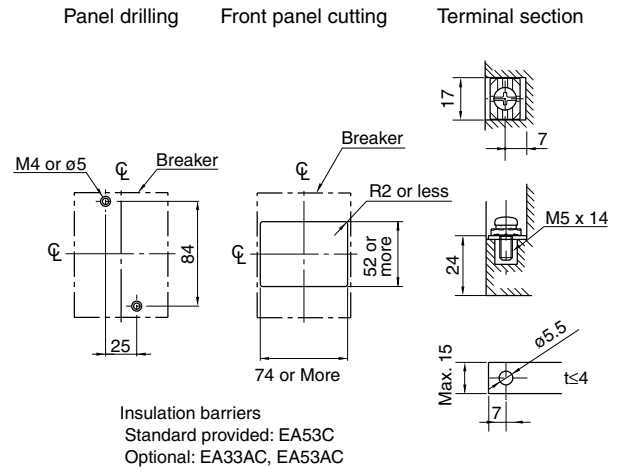
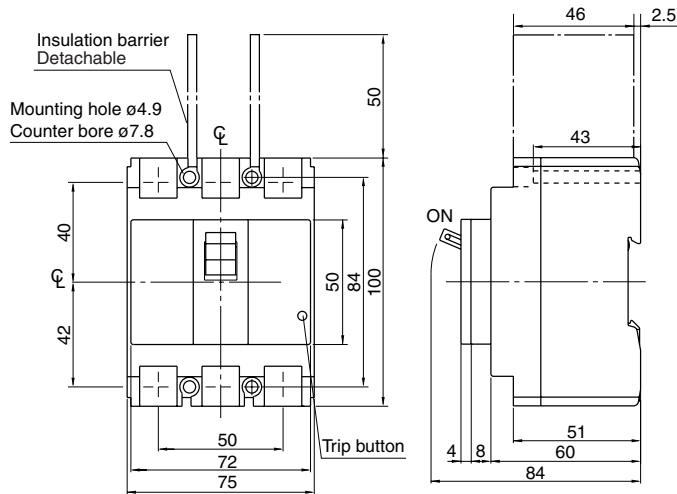

EA62C □ -CE

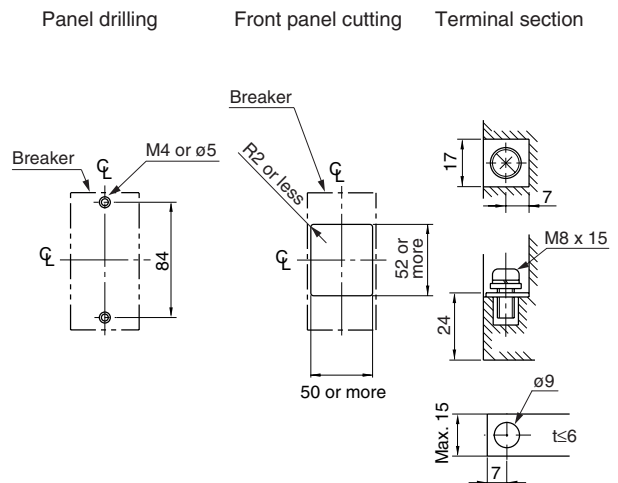
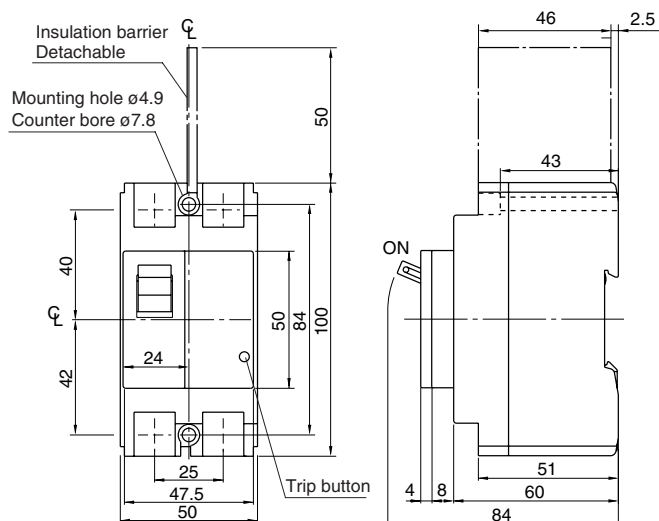

Molded Case Circuit Breakers

Dimensions

E series/2, 3-pole

■ Dimensions, mm

● Front mounting, front connection

EA63C □ -CE

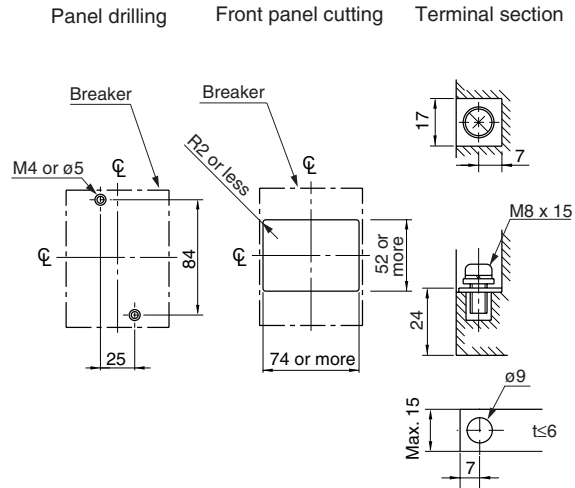
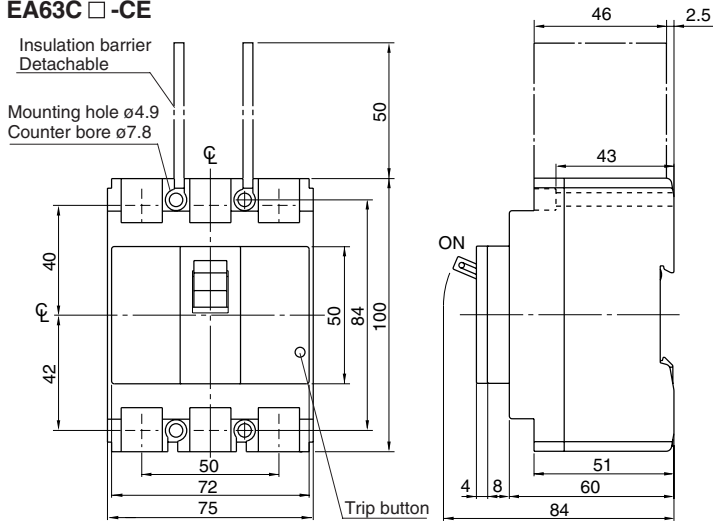

EA103AC □ -CE, 103C □ -CE

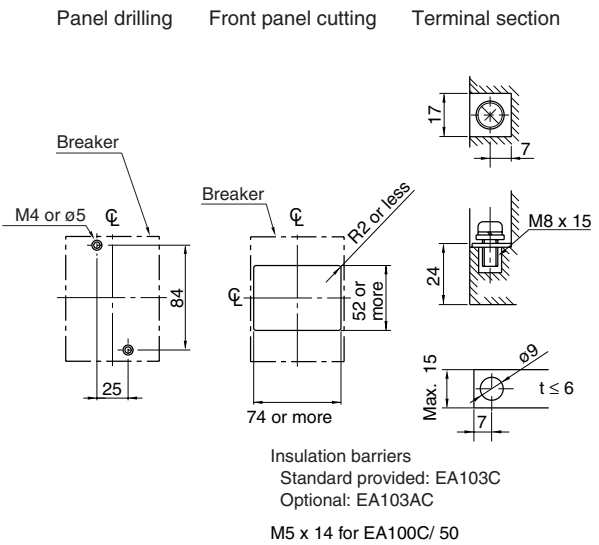
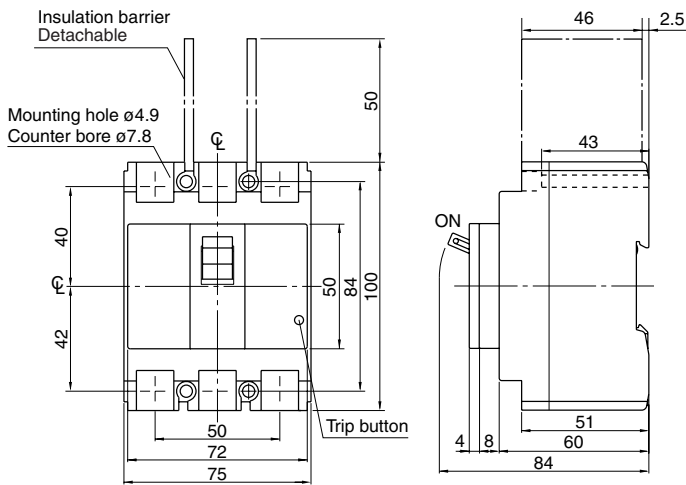

EA102C □ -CE

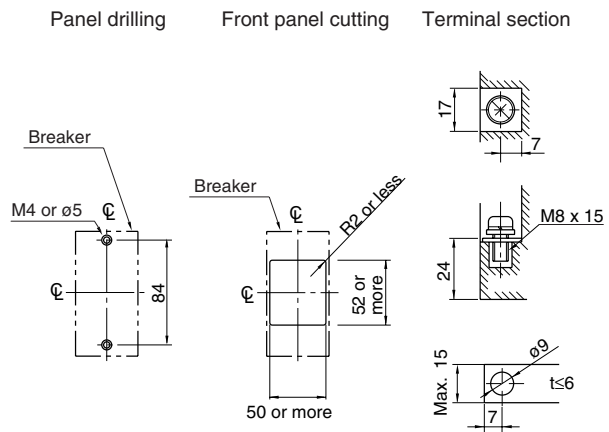
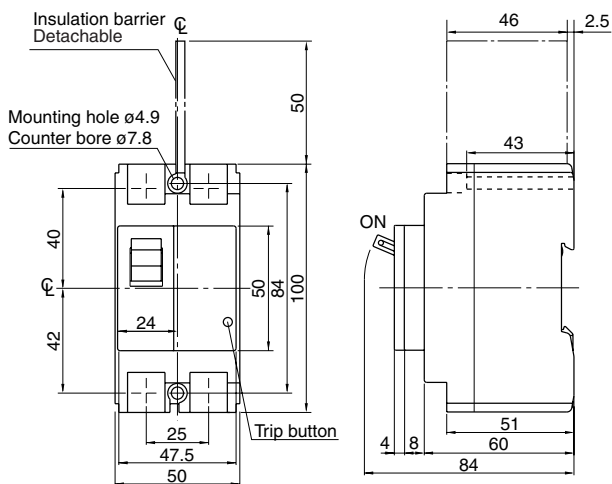

M5 x 14 for EA100C/ 50

Molded Case Circuit Breakers Dimensions E series/2, 3-pole

- Dimensions, mm
- Front mounting, front connection

EA202C □ -CE, 203C □ -CE

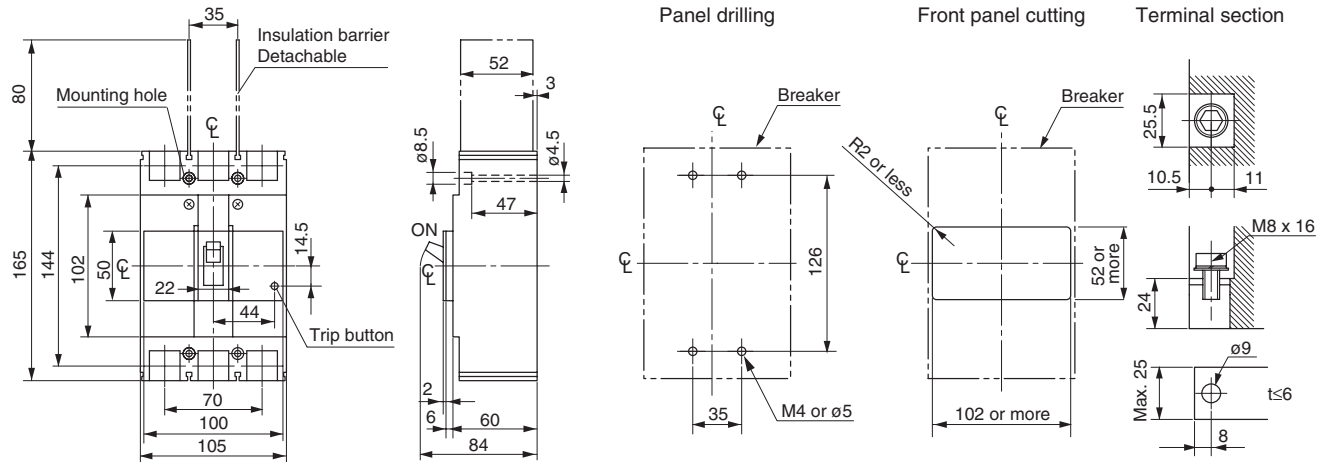

Note: 2-pole breaker is supplied in 3-pole frame with current carrying parts omitted from center pole.

EA402C □ -CE, 403C □ -CE

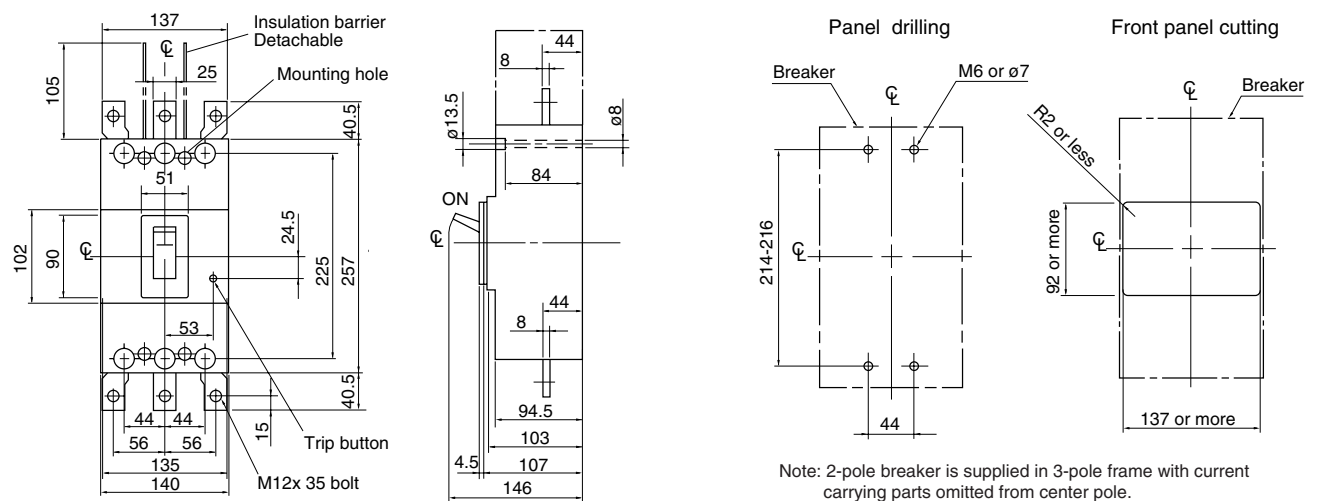

Note: 2-pole breaker is supplied in 3-pole frame with current carrying parts omitted from center pole.

EA603C □ -CE

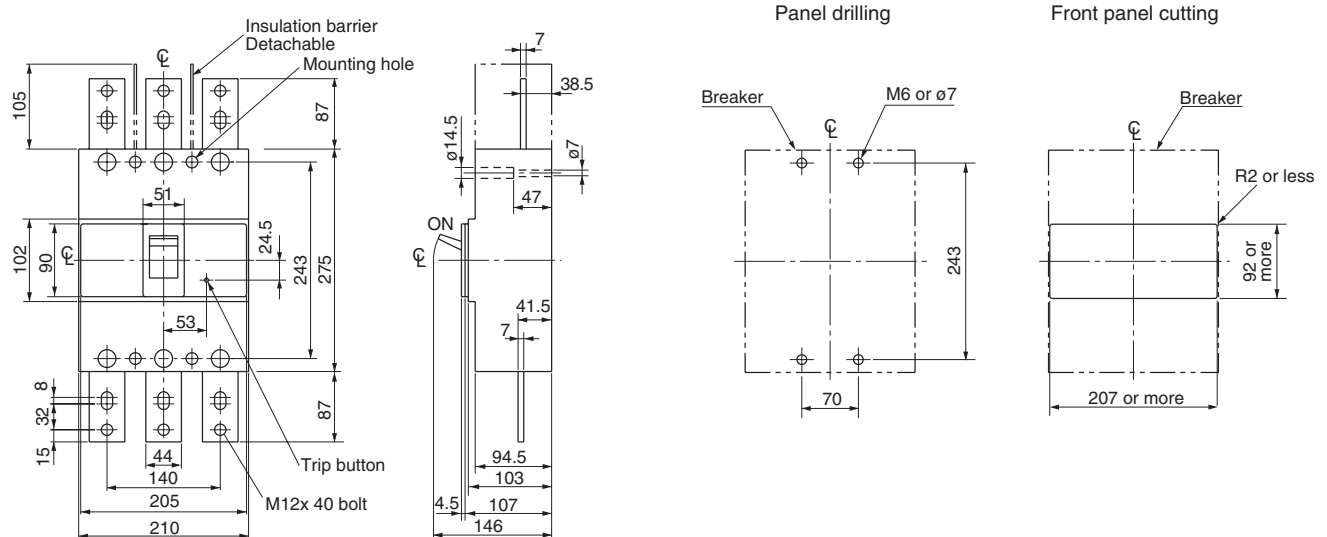

Molded Case Circuit Breakers

Dimensions

E series/2, 3, 4-pole

■ Dimensions, mm

● Front mounting, front connection

EA803C □ -CE

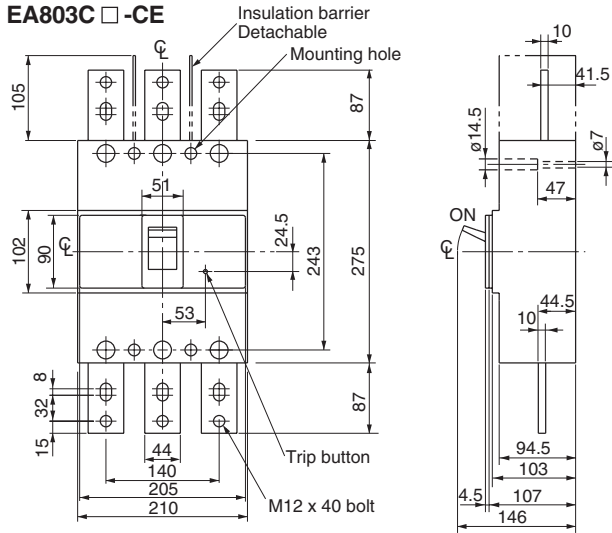

Panel drilling

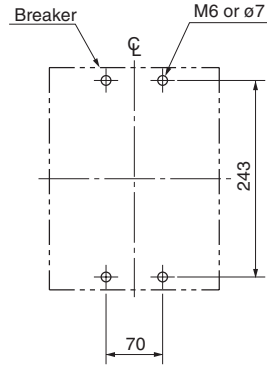

Front panel cutting

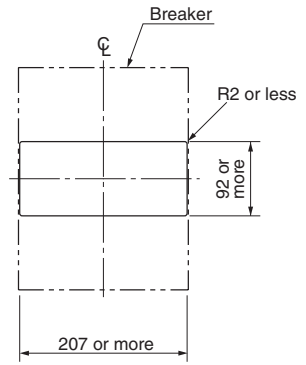

EA104B

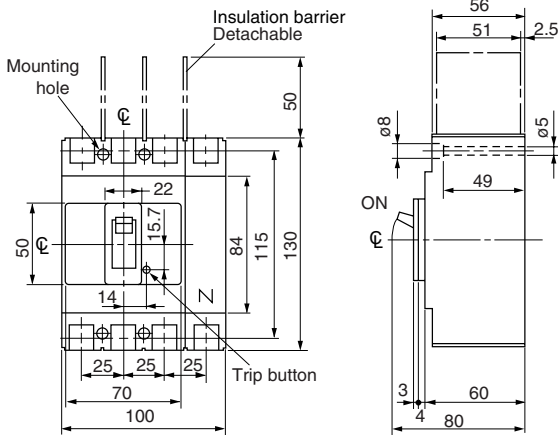

Panel drilling

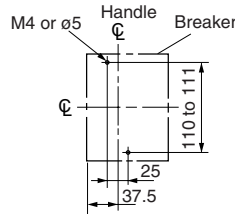

Front panel cutting

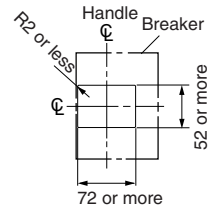

Terminal section

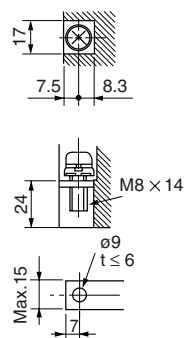

● Front mounting, rear connection (type X)

EA32AC □ -CE, 52AC □ -CE, 52C □ -CE

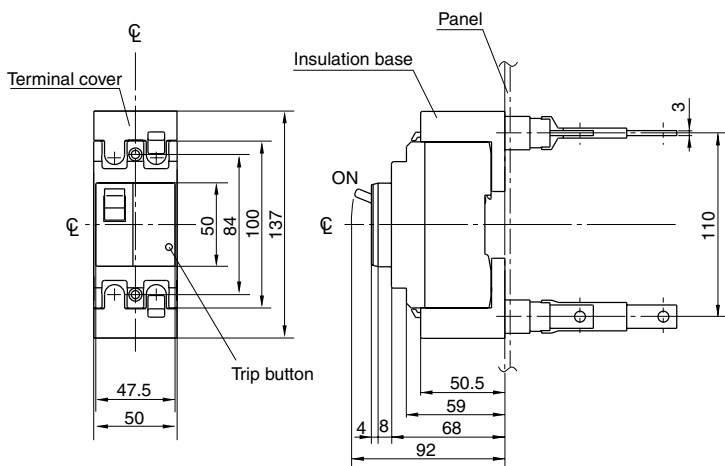

Panel drilling

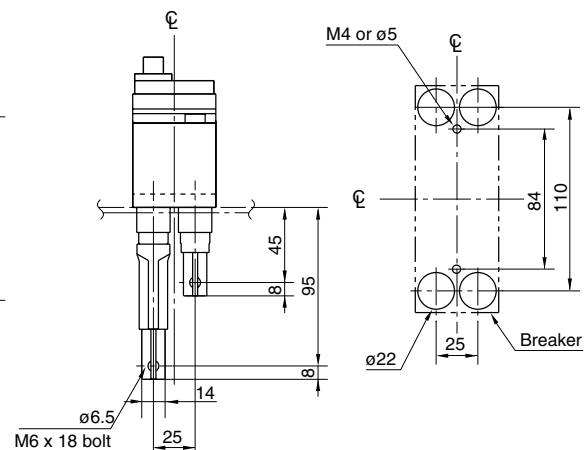

Molded Case Circuit Breakers Dimensions E series/2, 3-pole

■ Dimensions, mm

● Front mounting, rear connection (type X)

EA33AC □ -CE, 53AC □ -CE, 53C □ -CE

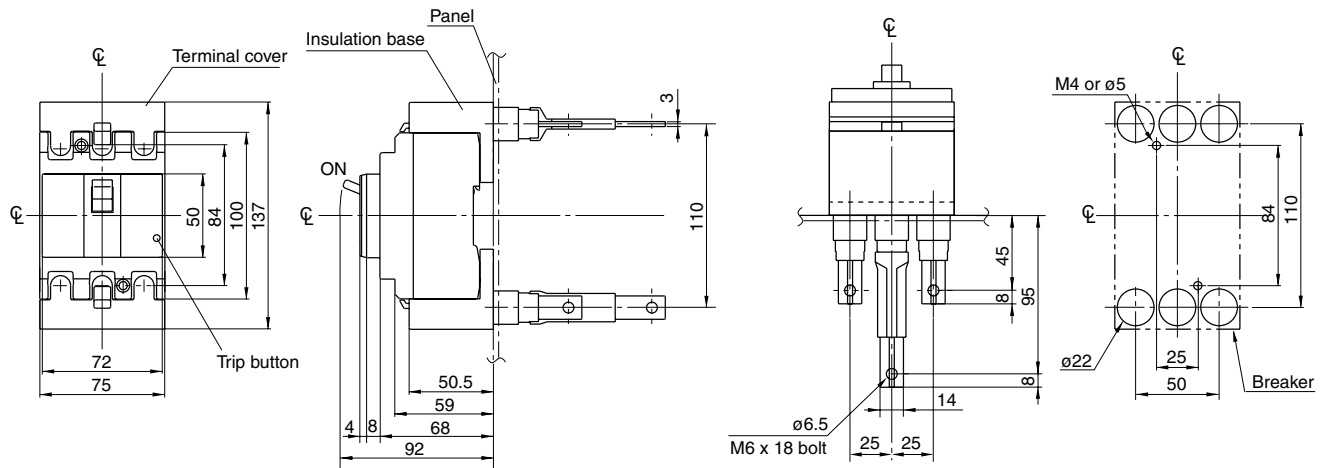

EA62C □ -CE

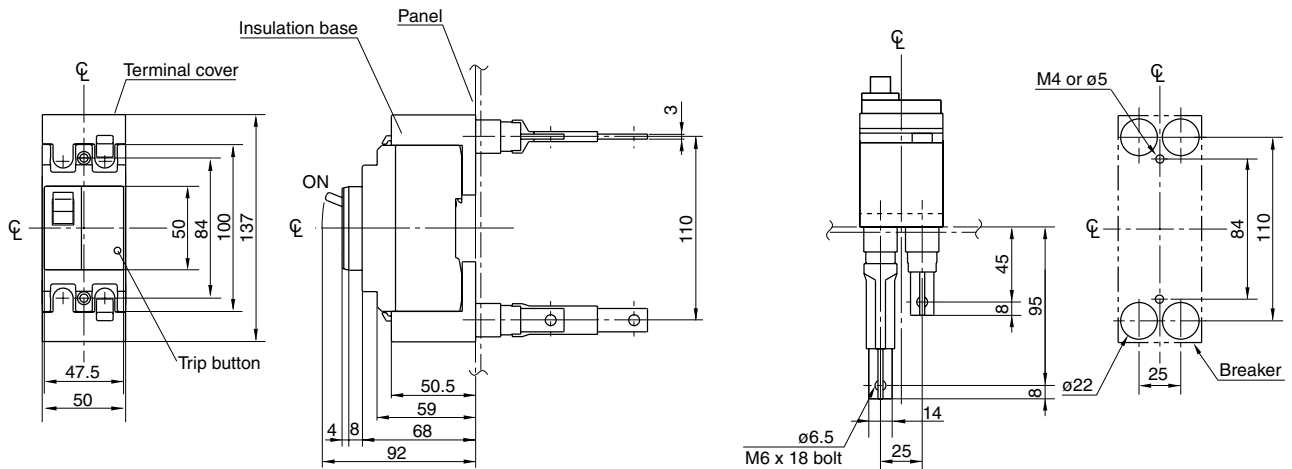

EA63C □ -CE

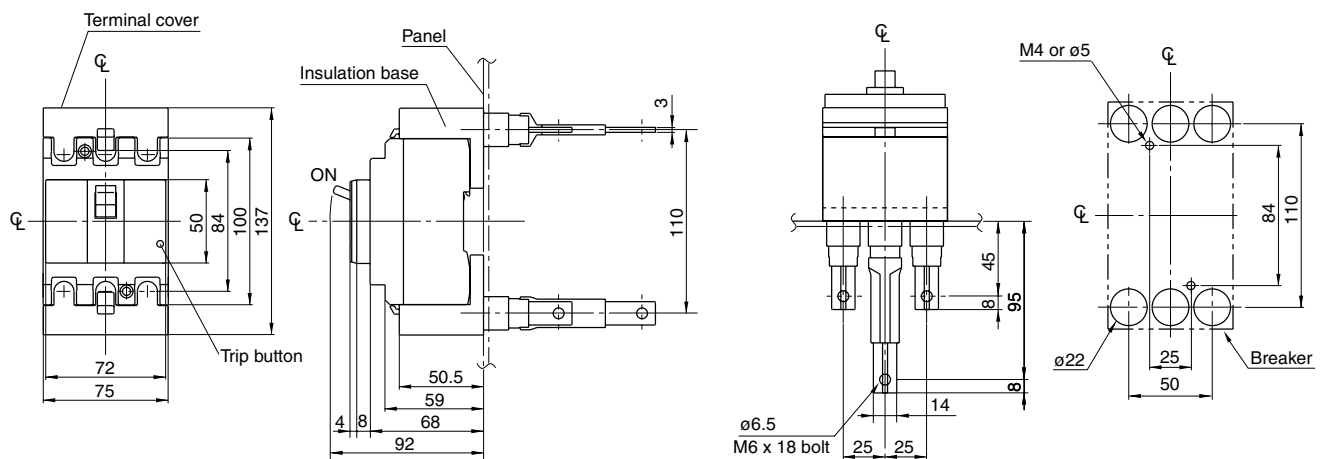

Molded Case Circuit Breakers

Dimensions

E series/2, 3-pole

■ Dimensions, mm

● Front mounting, rear connection (type X)

EA102C □ -CE

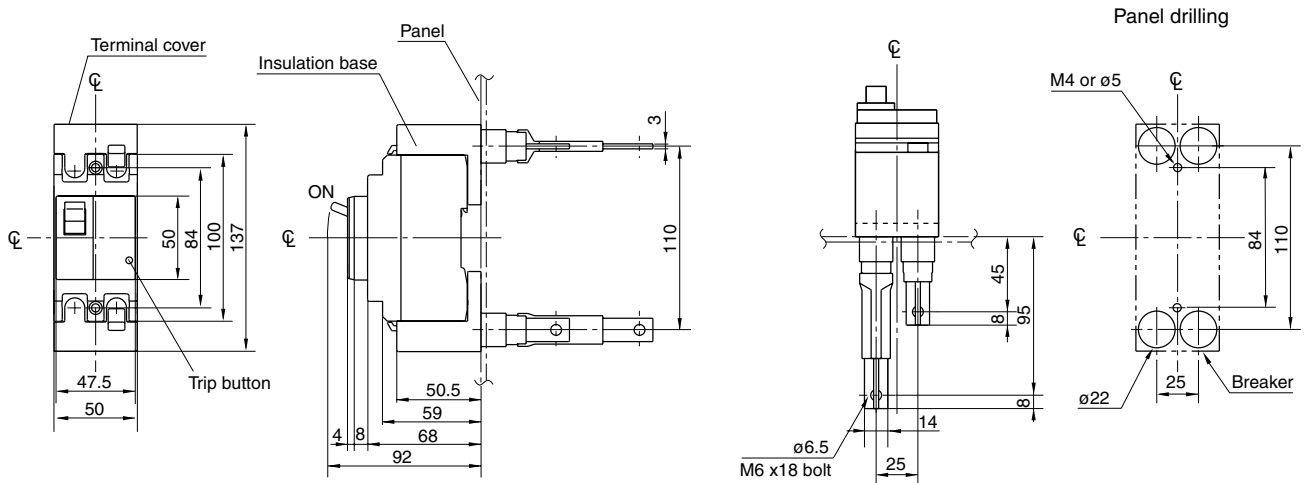

EA103AC □ -CE, 103C □ -CE

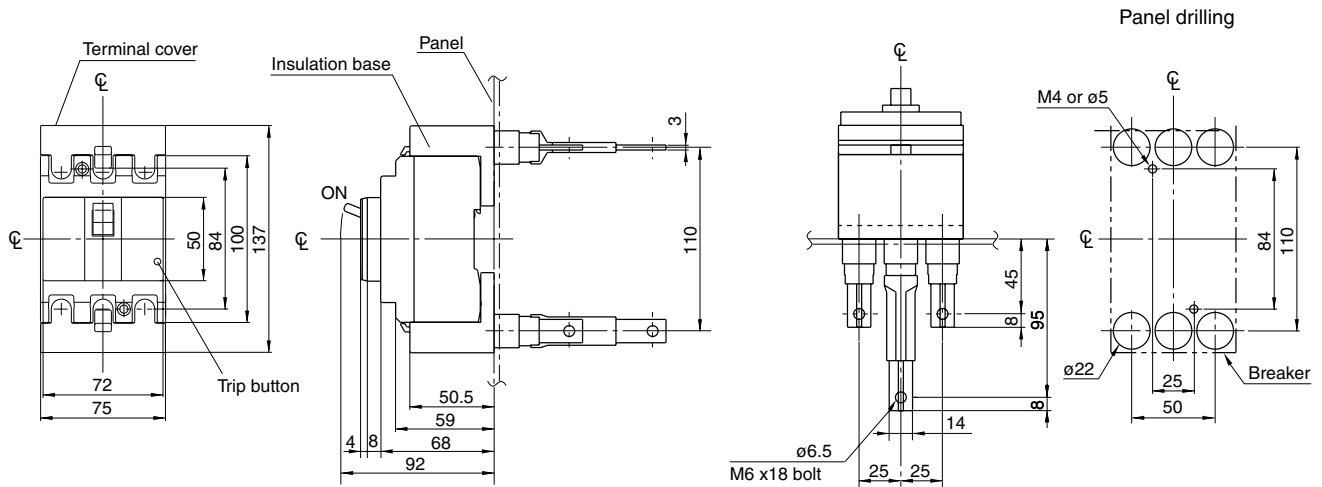

EA202C □ -CE, 203C □ -CE

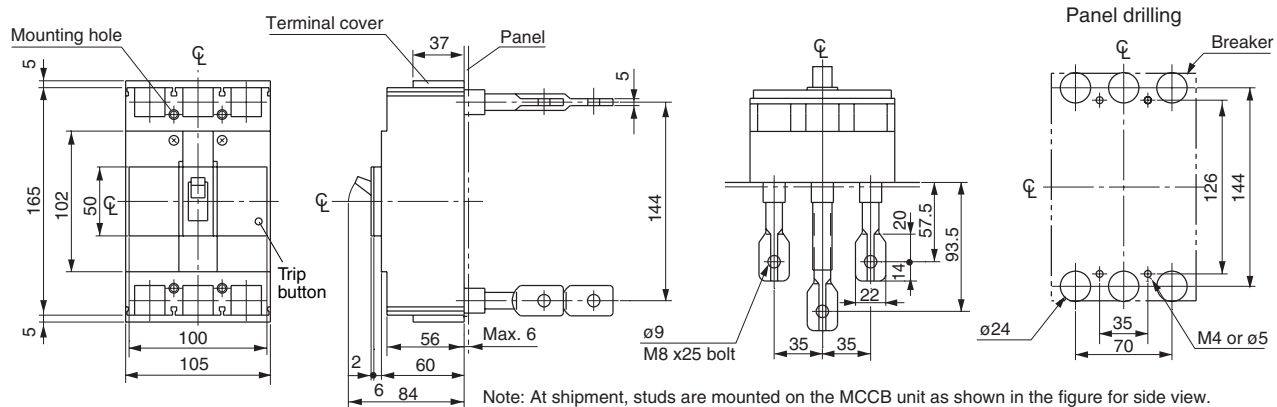

Note: At shipment, studs are mounted on the MCCB unit as shown in the figure for side view.

•Studs for line side terminal : Mounted horizontally.

•Studs for load side terminal : Mounted vertically.

Each stud can be turned by 90°.

2-pole breaker is supplied in 3-pole frame with current carrying parts omitted from center pole.

Molded Case Circuit Breakers Dimensions E series/ 2, 3-pole

■ Dimensions, mm

● Front mounting, rear connection (type X)

EA402C □ -CE, 403C □ -CE

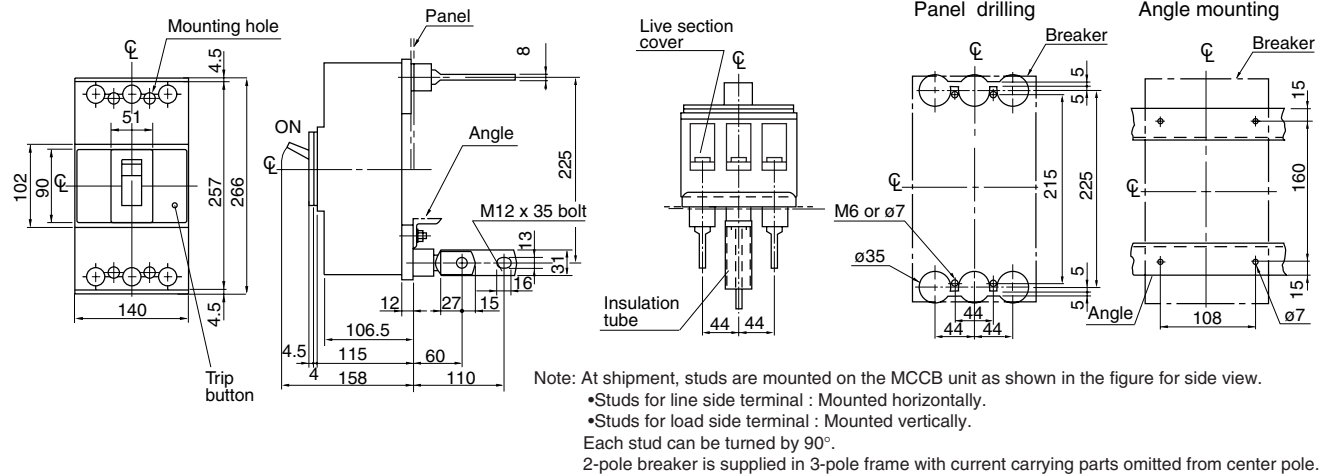

EA603C □ -CE

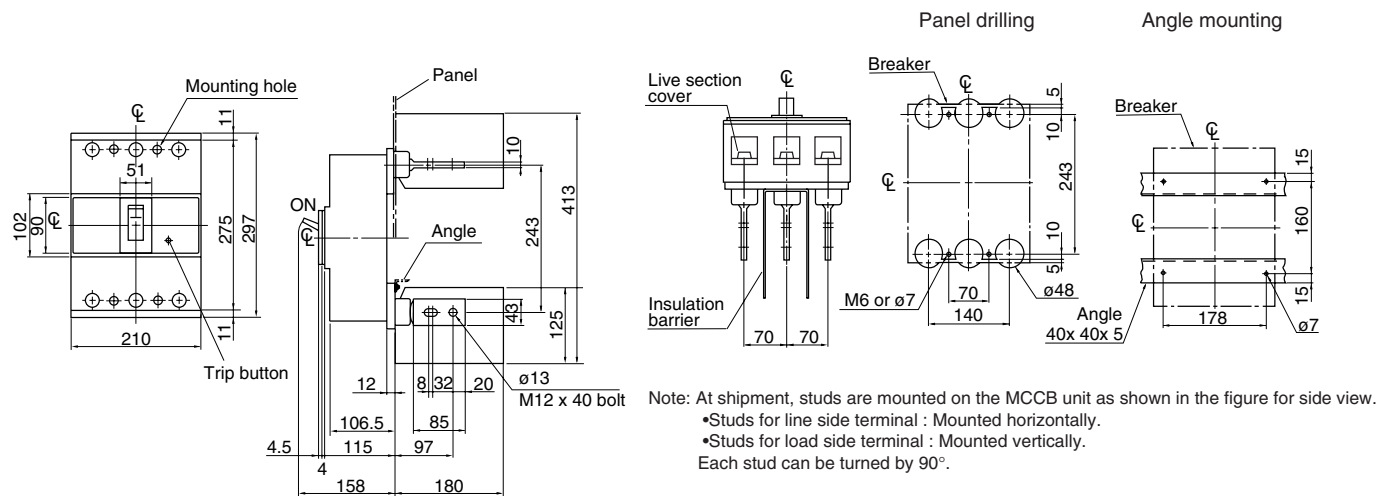

EA803C □ -CE

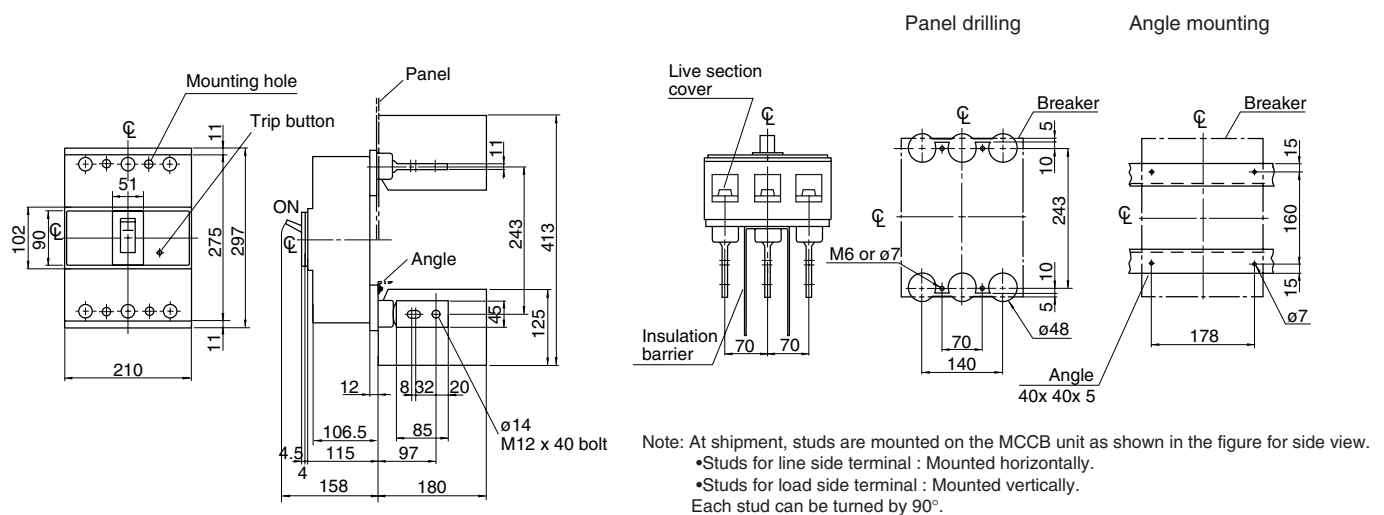

Molded Case Circuit Breakers

Dimensions

L, H series/2, 3-pole

■ Dimensions, mm

● Front mounting, front connection

LA53B

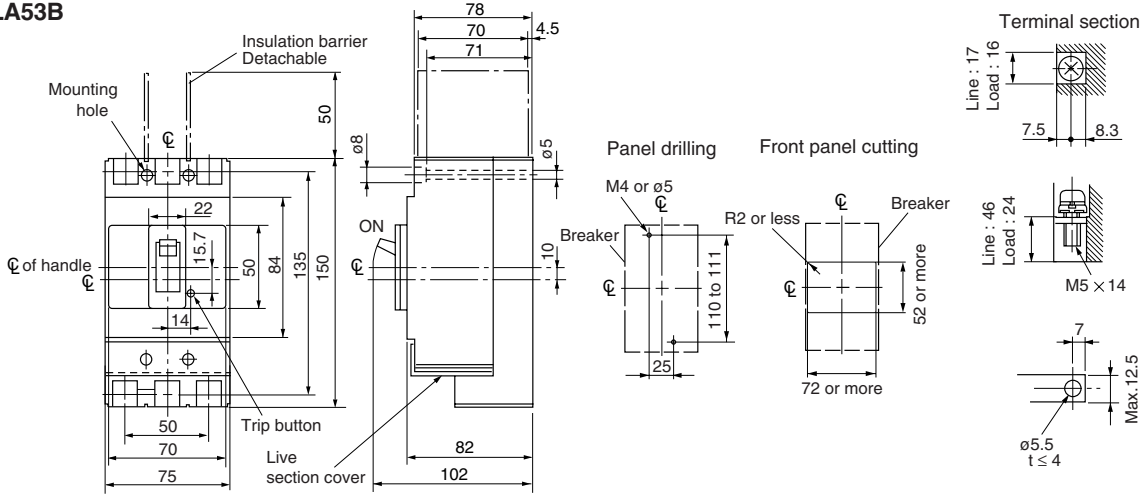

H52BA, H53BA, H102BA, H103BA

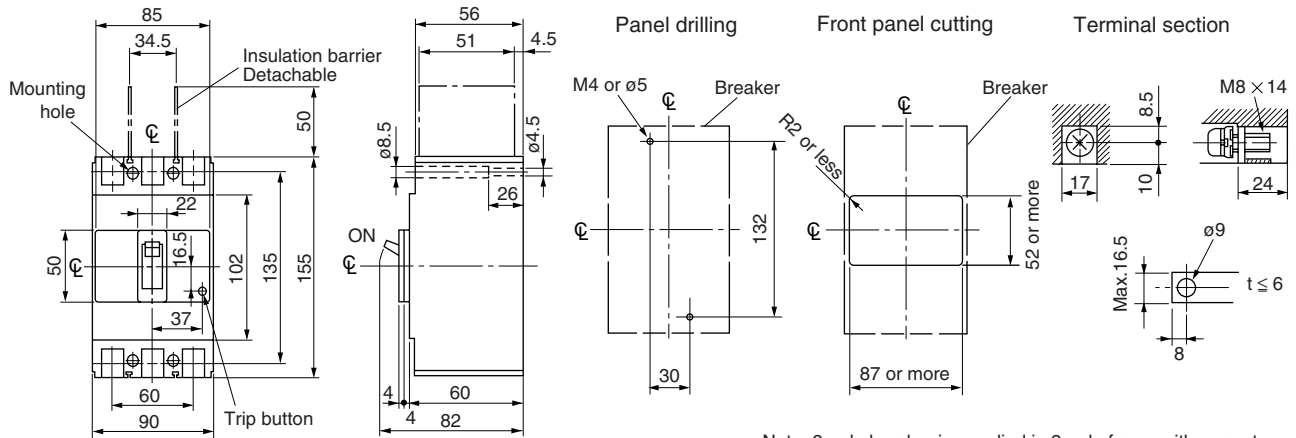

Note: 2-pole breaker is supplied in 3-pole frame with current carrying parts omitted from center pole.

H202BA, H203BA

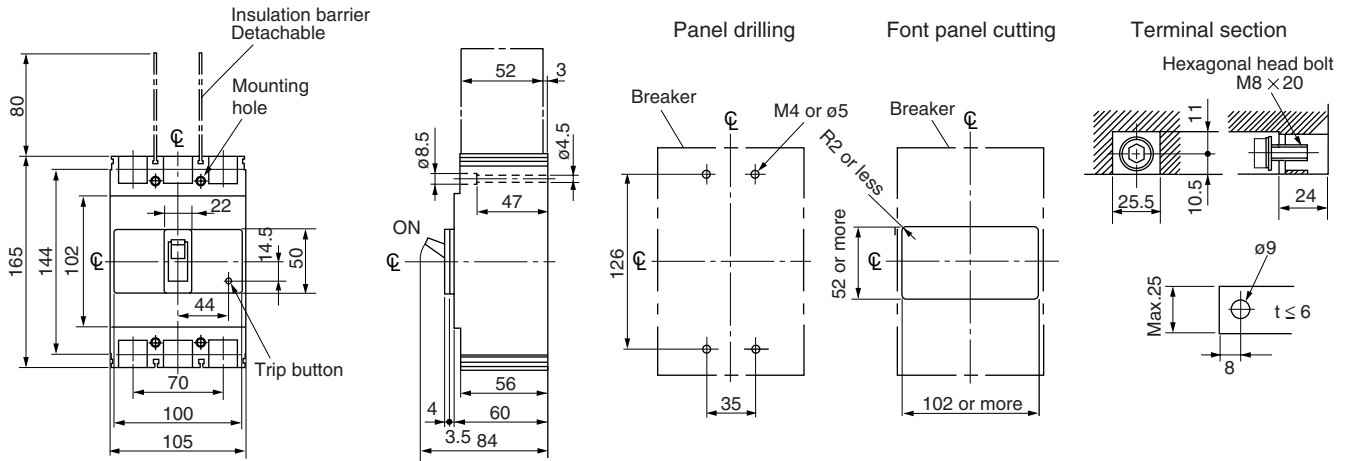

Note: 2-pole breaker is supplied in 3-pole frame with current carrying parts omitted from center pole.

Molded Case Circuit Breakers Dimensions H series/2, 3-pole

- Dimensions, mm
- Front mounting, front connection

H103R, H203R

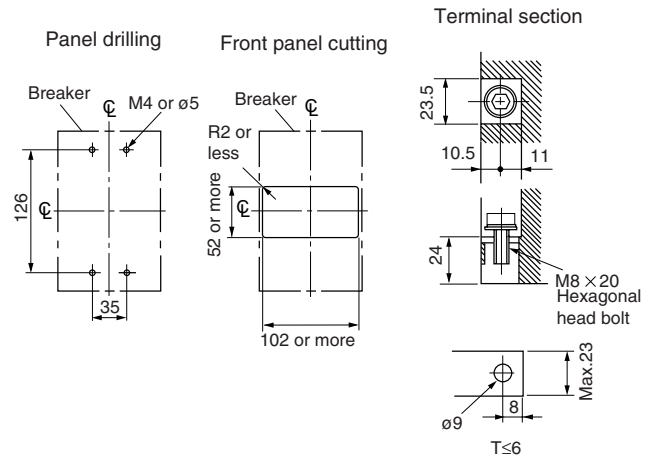
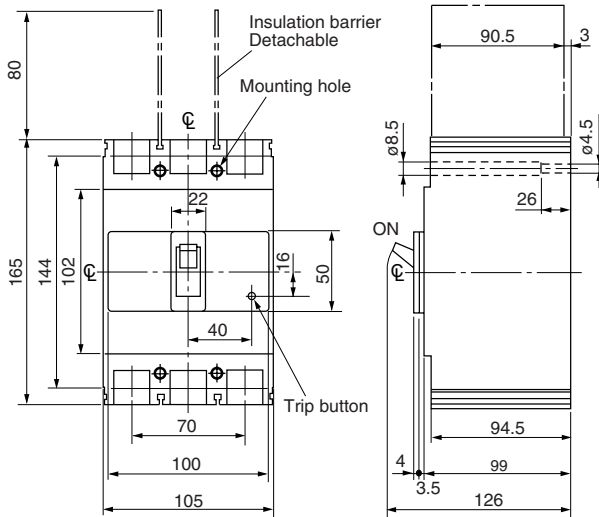

Note: 2-pole breaker is supplied in 3-pole frame with current carrying parts omitted from center pole.

H402B, H403B, H403R

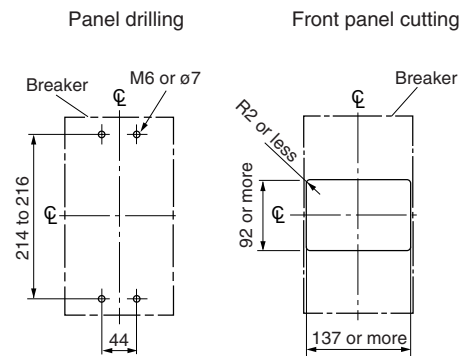
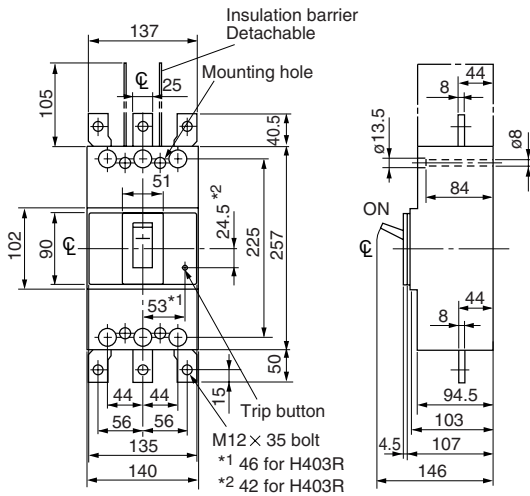

Note: 2-pole breaker is supplied in 3-pole frame with current carrying parts omitted from center pole.

H603B, H603R

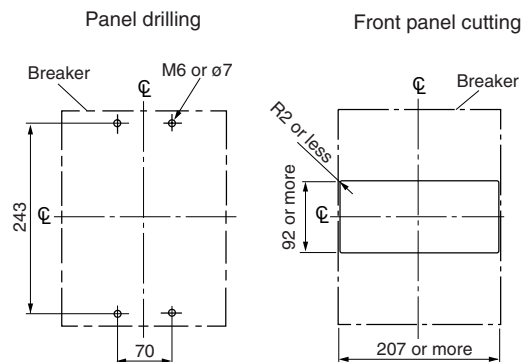
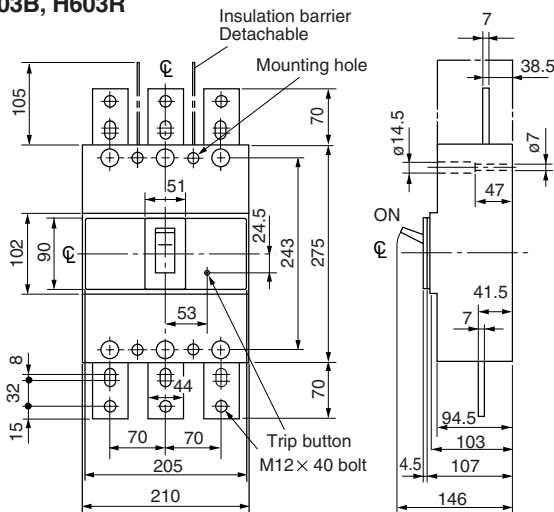

Molded Case Circuit Breakers

Dimensions

H series/ 3-pole

■ Dimensions, mm

● Front mounting, rear connection (type X)

H803B, H803R

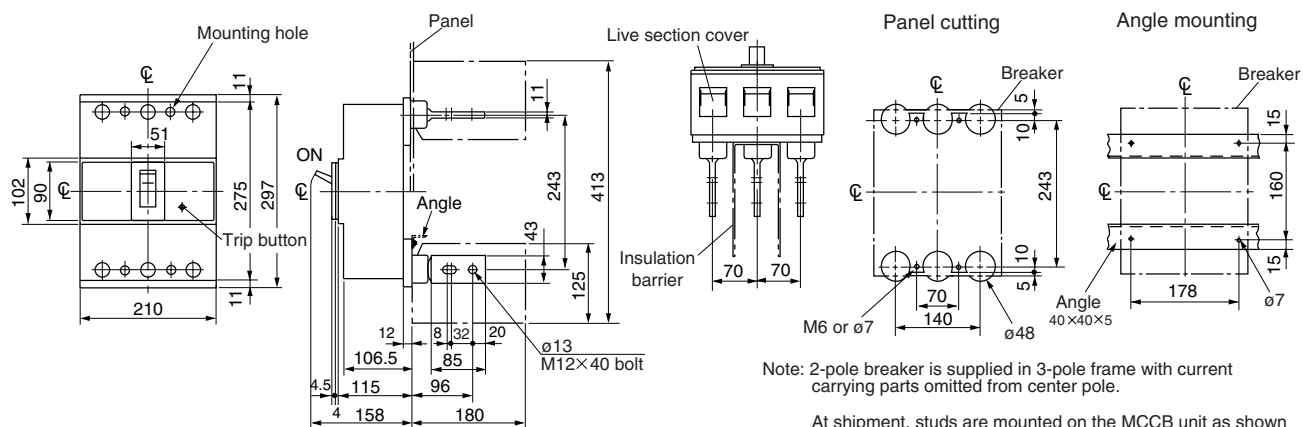

Note: 2-pole breaker is supplied in 3-pole frame with current carrying parts omitted from center pole.

At shipment, studs are mounted on the MCCB unit as shown in the figure for side view.

- Studs for line side terminals : mounted horizontally
- Studs for load side terminals : mounted vertically

Each stud can be mounted both horizontally or vertically.

Dimensions for reference only. Confirm before construction begins.

- Dimensions, inch [mm]
- Front mounting, front connection

SA52RCUL

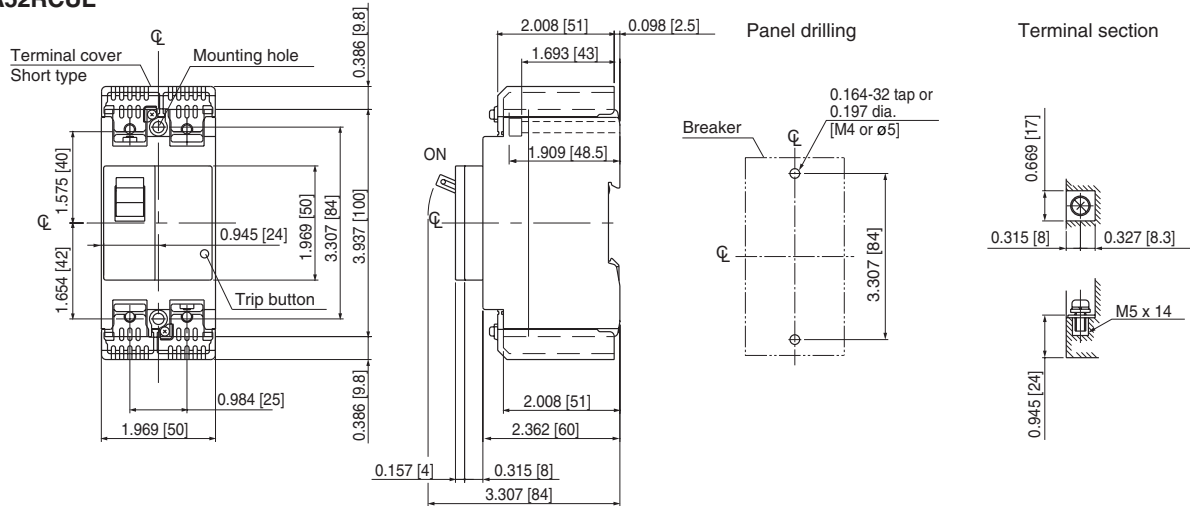

SA53RCUL

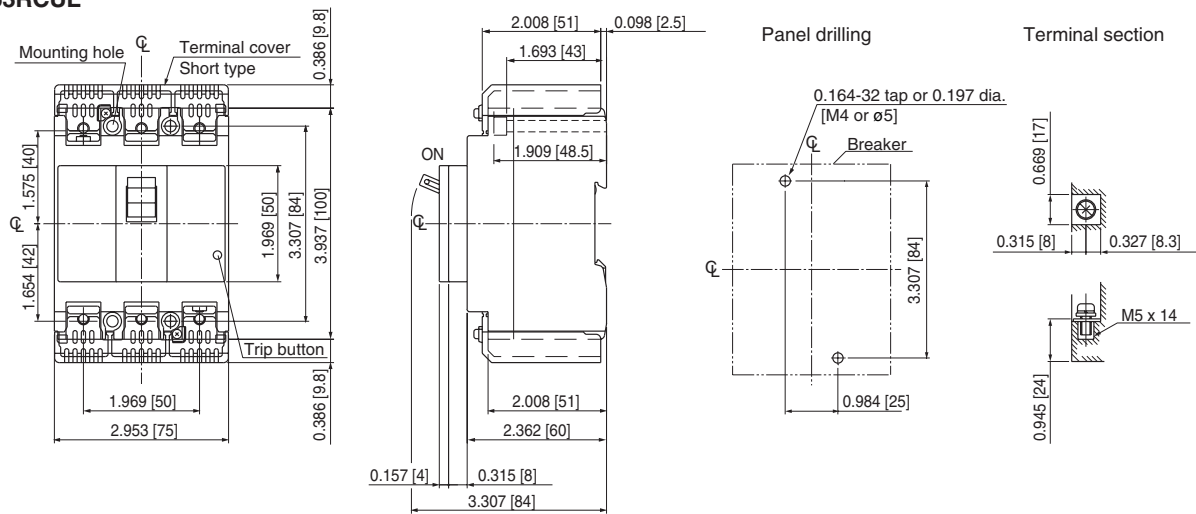

SA102CUL, SA103CUL, SA102RCUL, SA103RCUL

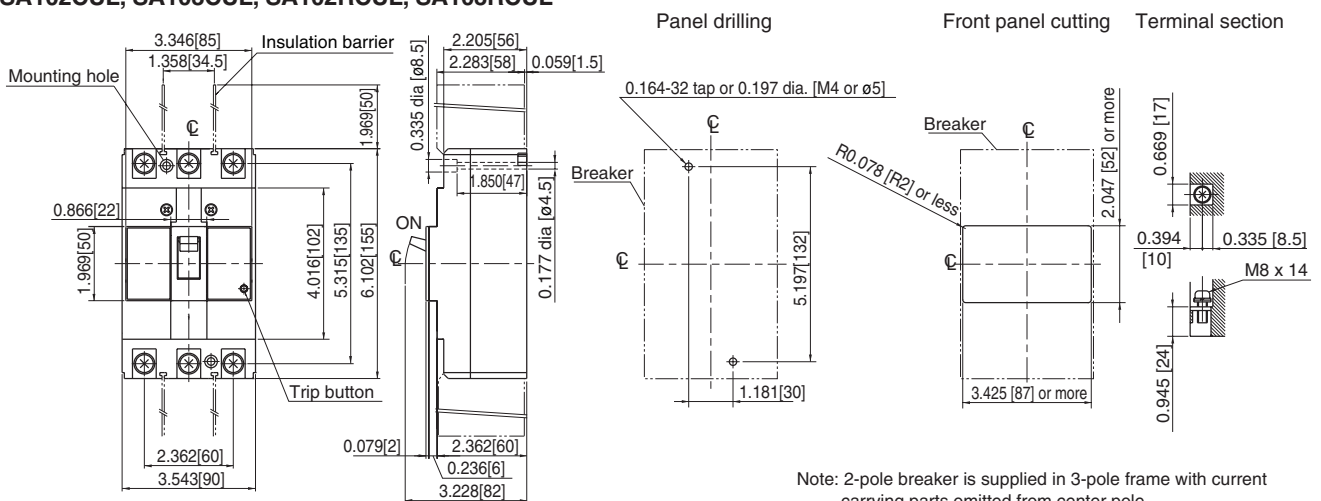

Note: 2-pole breaker is supplied in 3-pole frame with current carrying parts omitted from center pole.

Molded Case Circuit Breakers

Dimensions

UL Listed

- Dimensions, inch [mm]
- Front mounting, front connection

SA202CUL, SA203CUL

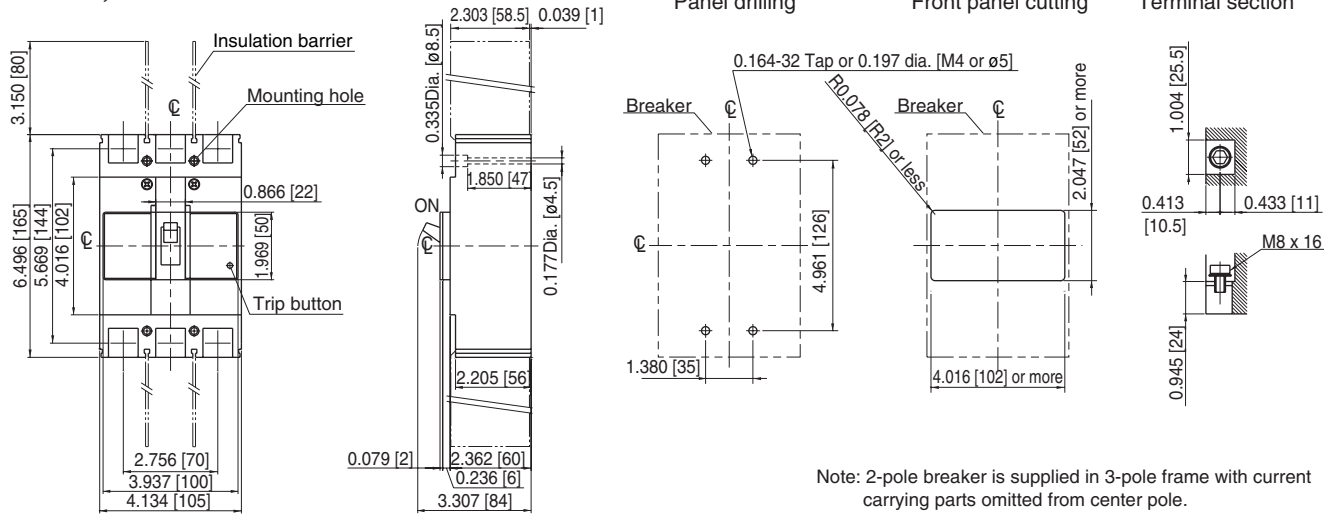

SA202RCUL, SA203RCUL

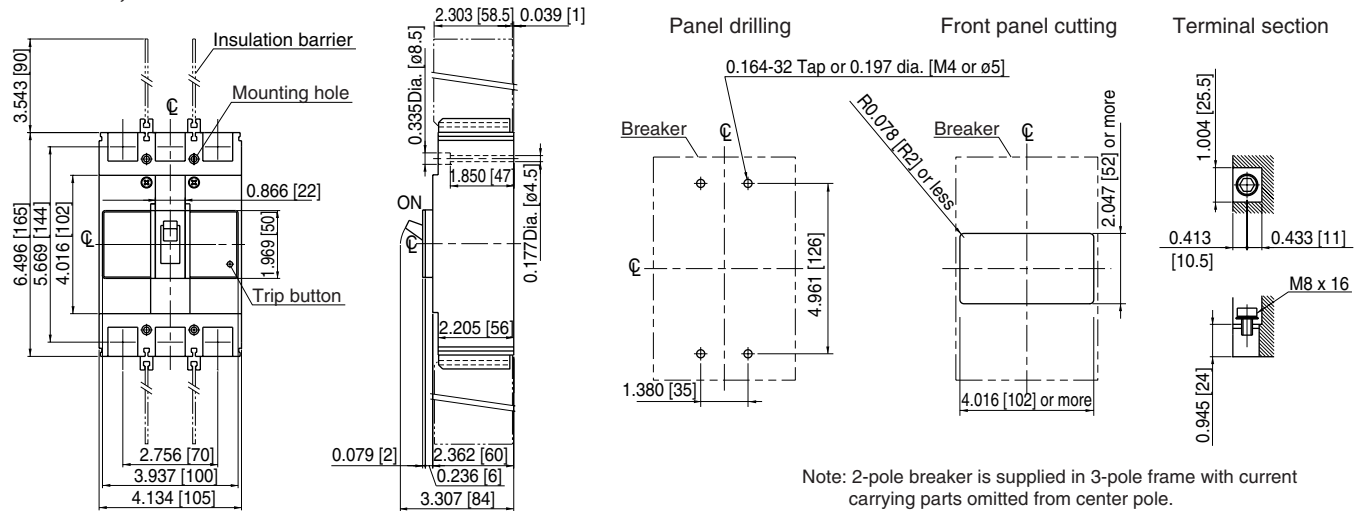

SA402CUL, SA403CUL, SA402RCUL, SA403RCUL

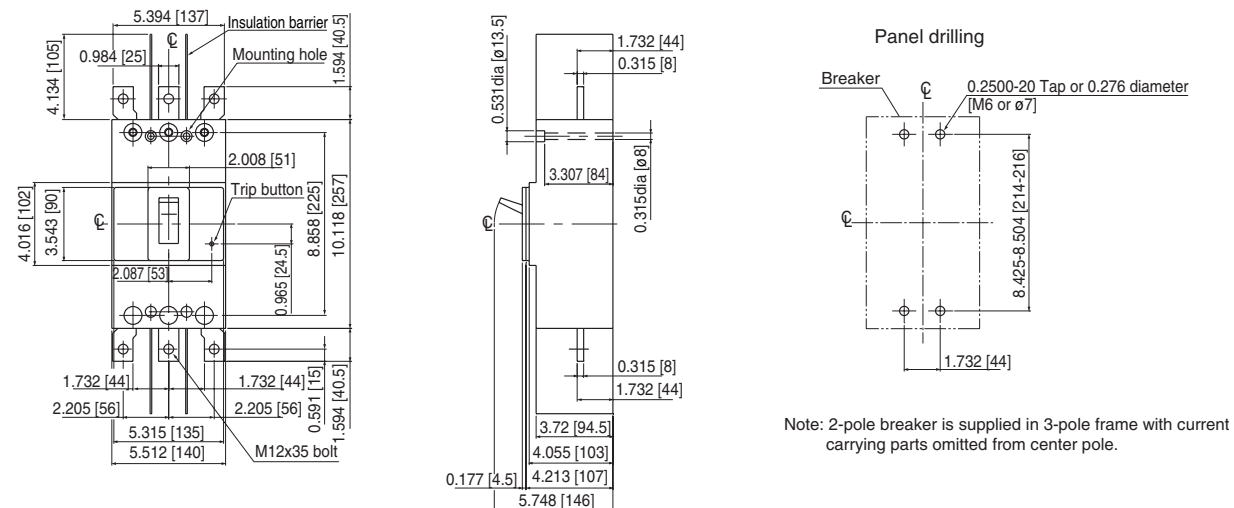

■ Dimensions, inch [mm]

● Front mounting, front connection

SA603RCUL

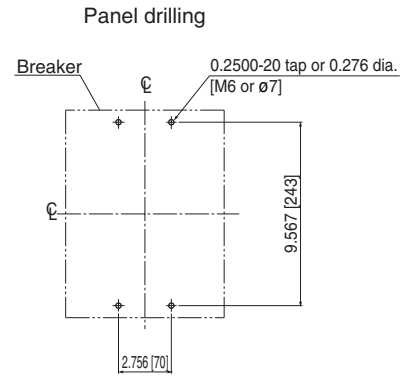
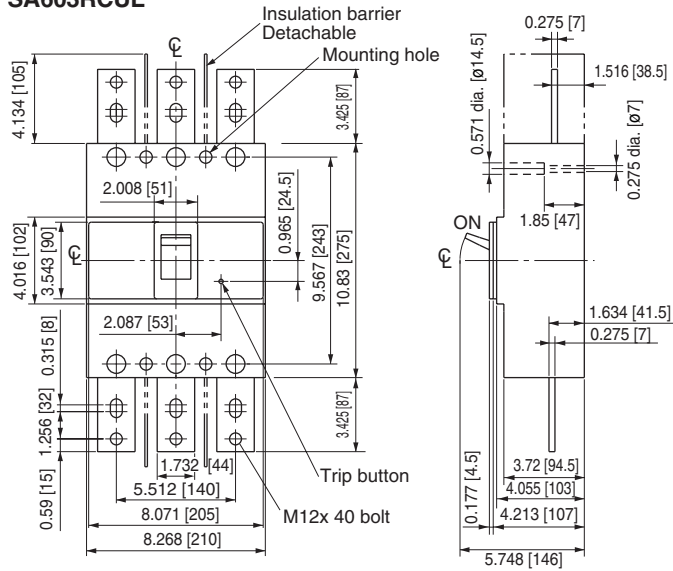

Note: 2-pole breaker is supplied in 3-pole frame with current carrying parts omitted from center pole.

SA803RCUL

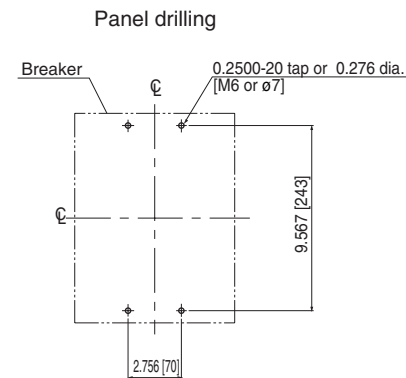
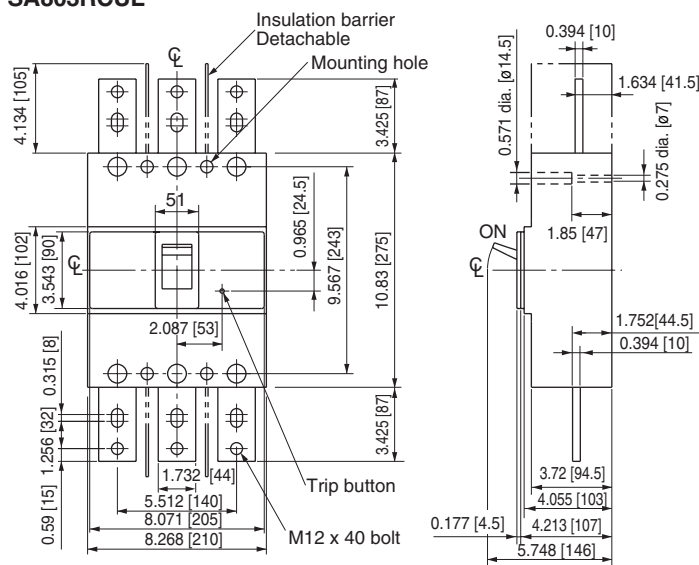

Note: 2-pole breaker is supplied in 3-pole frame with current carrying parts omitted from center pole.

06

Molded Case Circuit Breakers

Dimensions

UL Listed

- Dimensions, inch [mm]
- Front mounting, front connection

EA102CUL

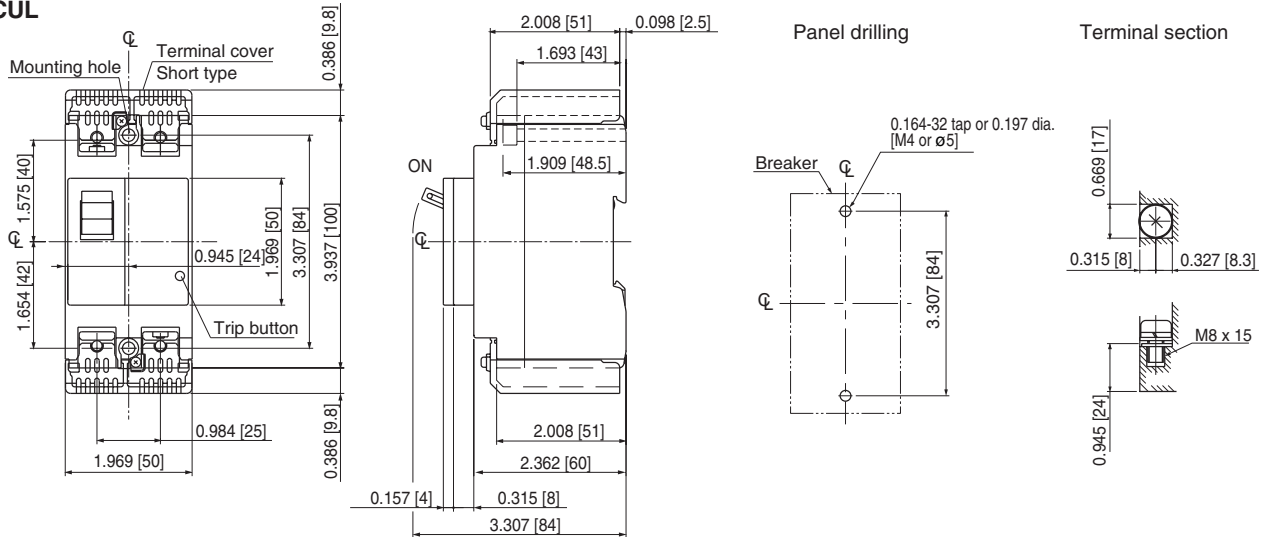

EA103CUL

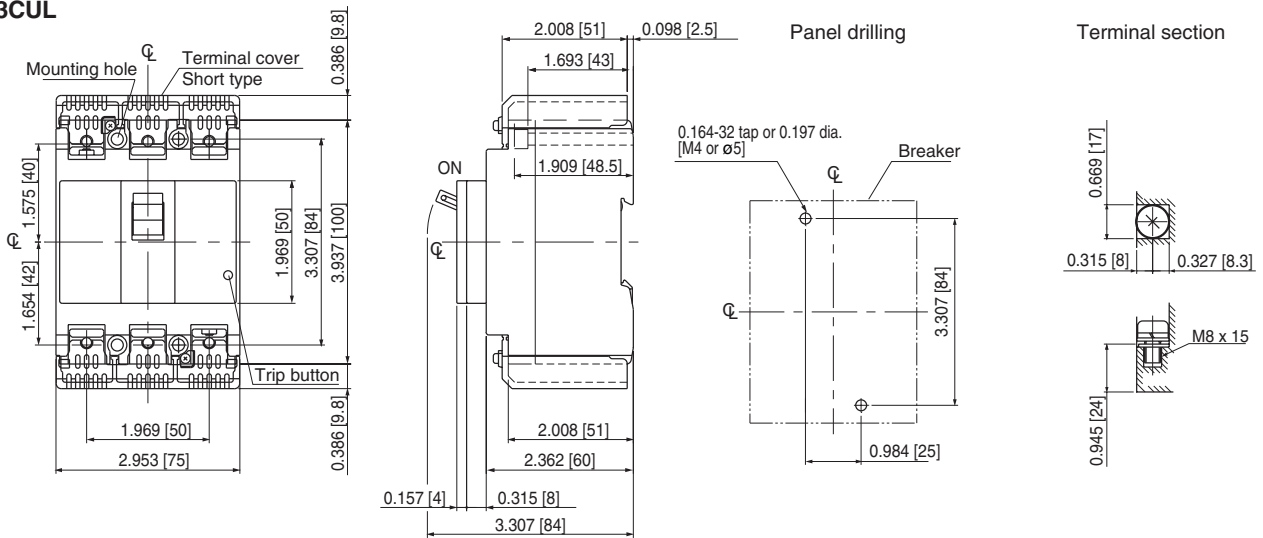

Dimensions for reference only. Confirm before construction begins.

■ S and E series, 2, 3-pole

SA30C, SA50C, SA50RC
EA30AC, EA50AC, EA50C

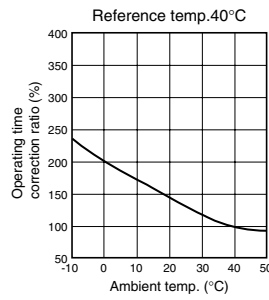
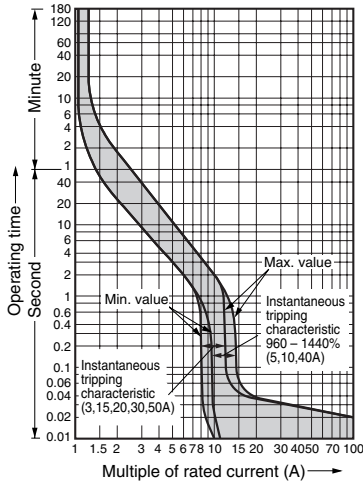

SA100C, SA100RC

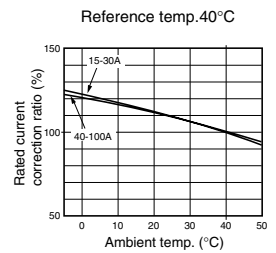
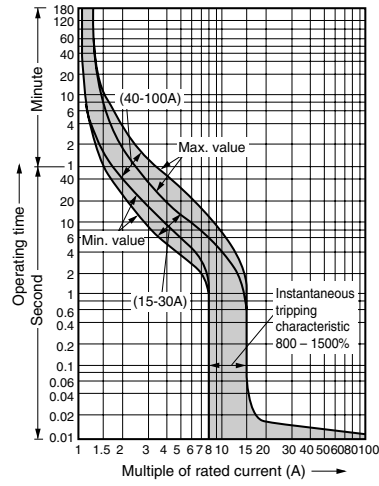

SA60C, SA60RC
EA60C

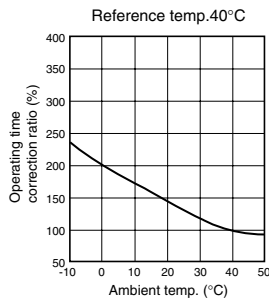
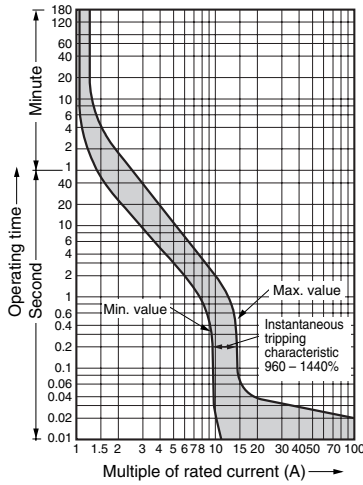

SA225C, SA225RC
EA225C

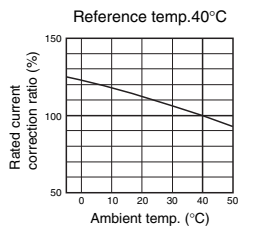
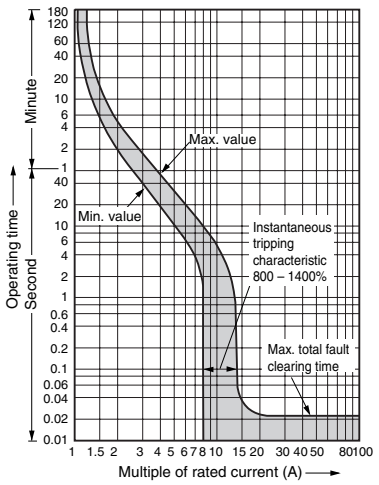

EA100AC, EA100C

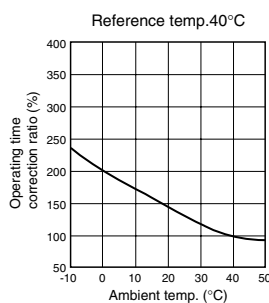
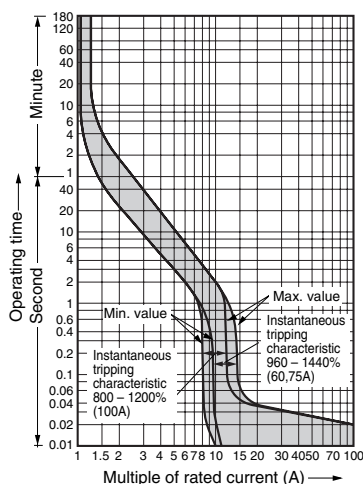

SA400C, SA400RC
EA400C

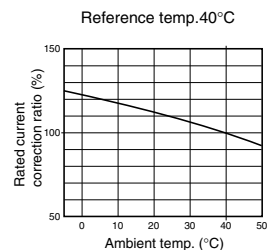
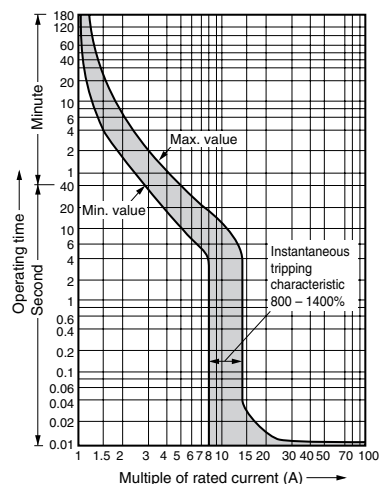

Molded Case Circuit Breakers

Characteristic curves

Line protection

■ S and E series, 3-pole

SA600RC
EA600C

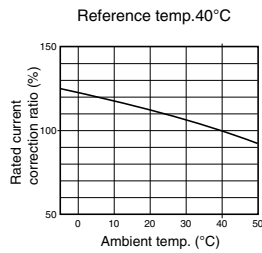
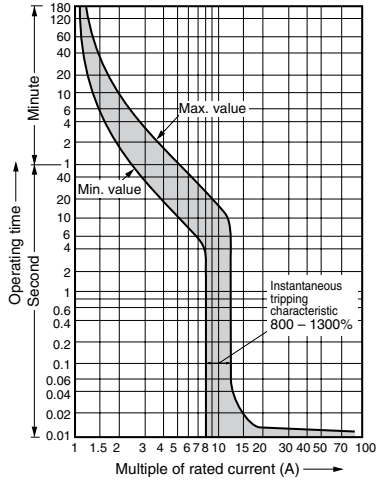

SA800RC
EA800C

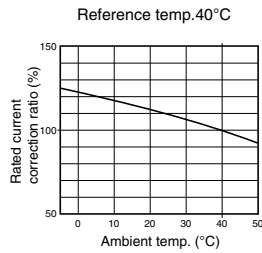
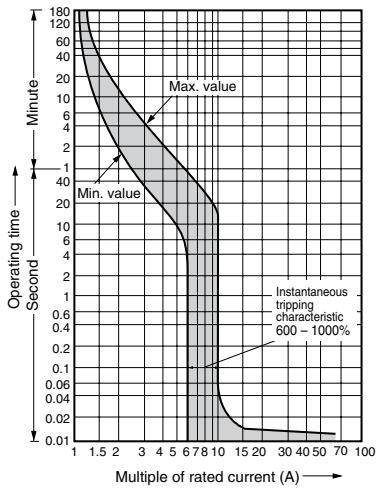

Molded Case Circuit Breakers Characteristic curves Line protection

■ S and E series, 4-pole

SA54B

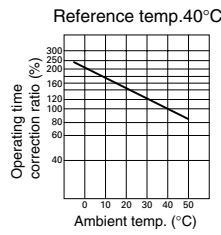
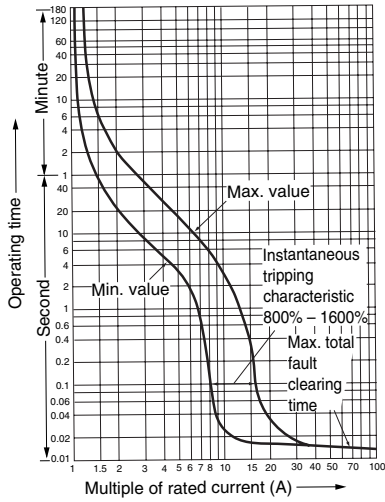

SA204R

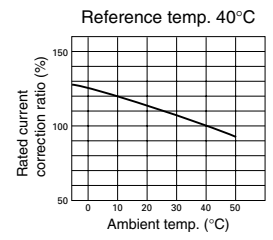
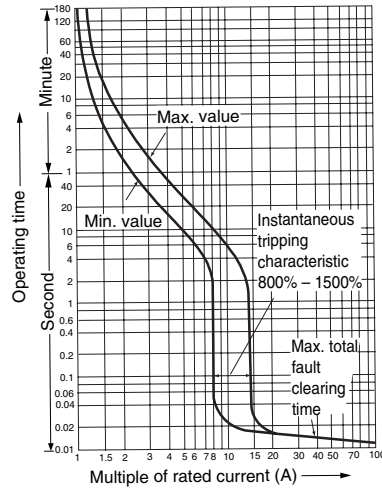

EA104B

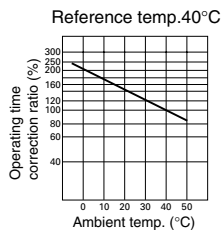
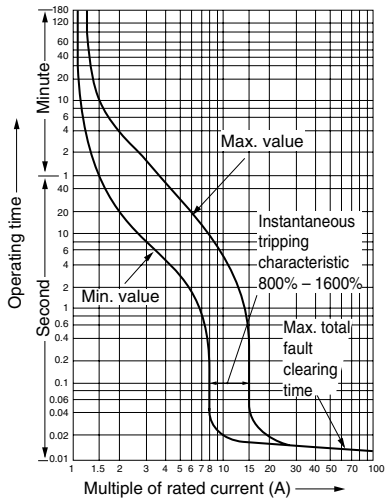

SA404HA

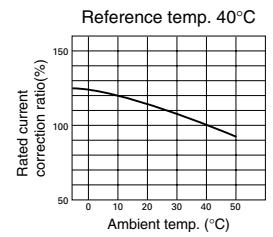
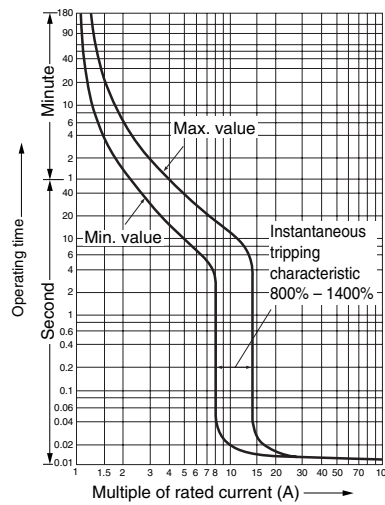

SA104R

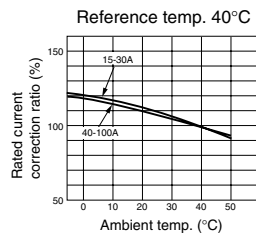
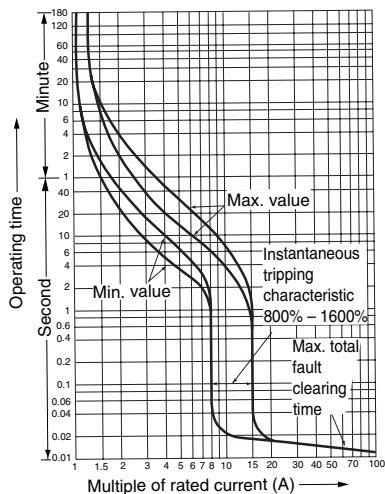

SA604H

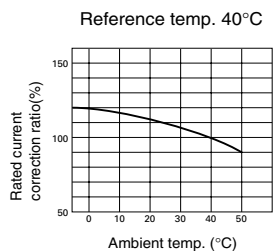
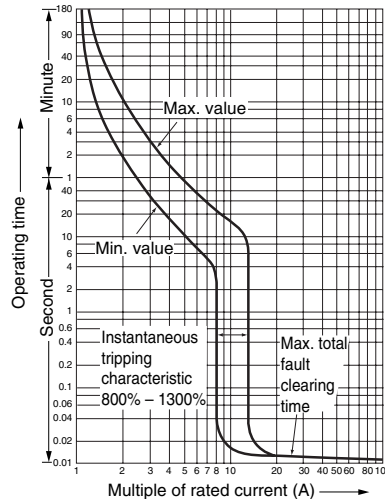

Molded Case Circuit Breakers

Characteristic curves

Line protection

■ S series, 4-pole

SA804H

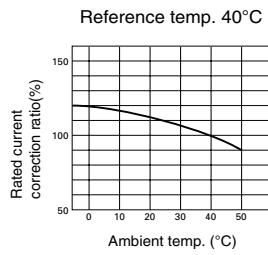
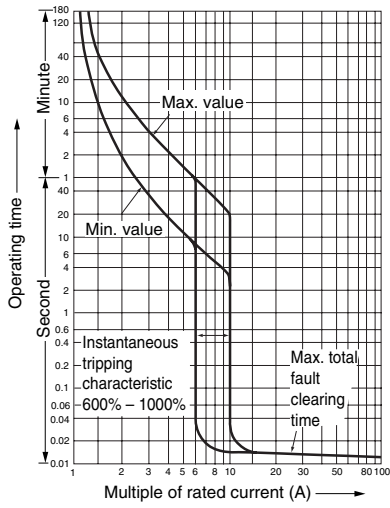

■ L series, 3-pole

LA50B

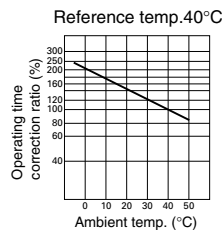
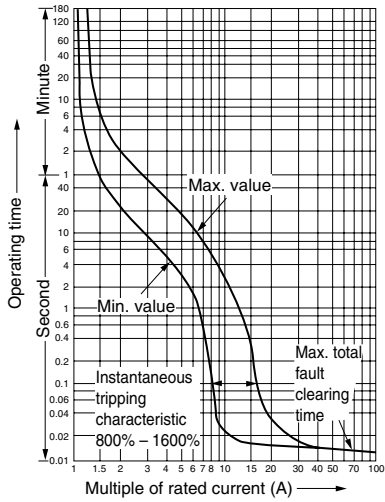

■ H series, 2, 3-pole

H225BA, H225R

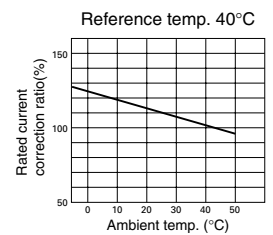
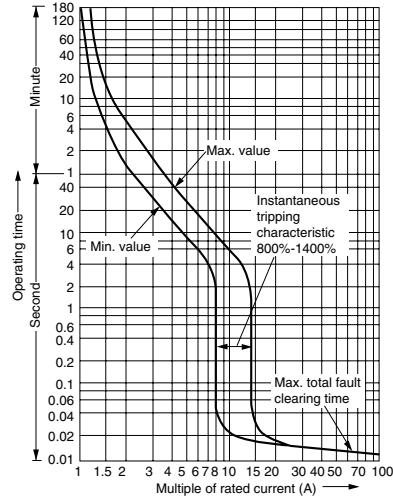

■ H series, 2, 3-pole

H50BA, H100BA

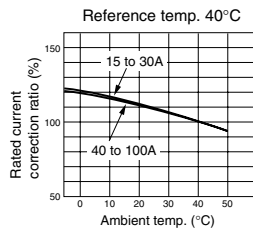
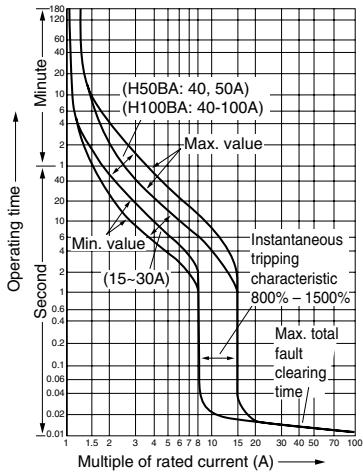

H400B, H400R

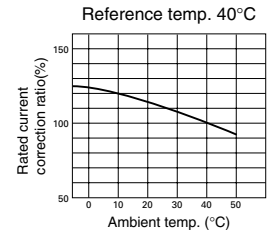
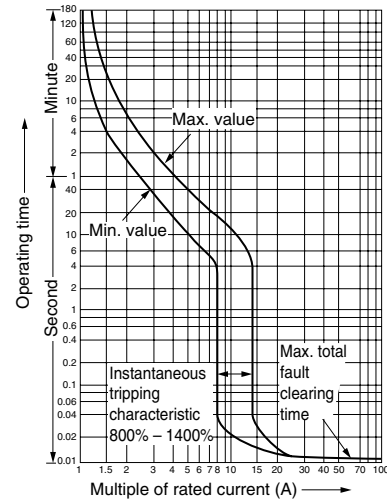

H100R

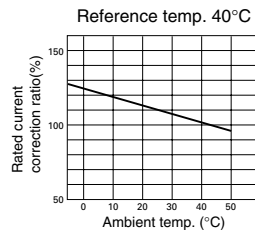
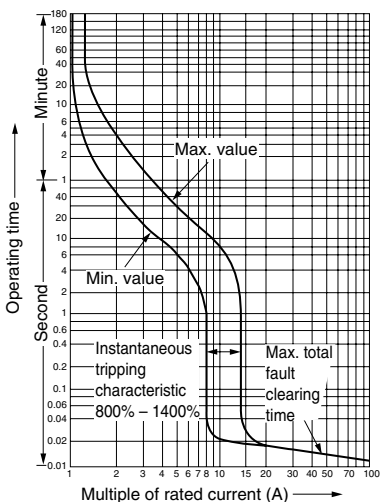

H600B, H600R

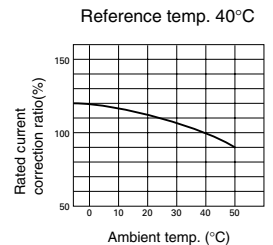
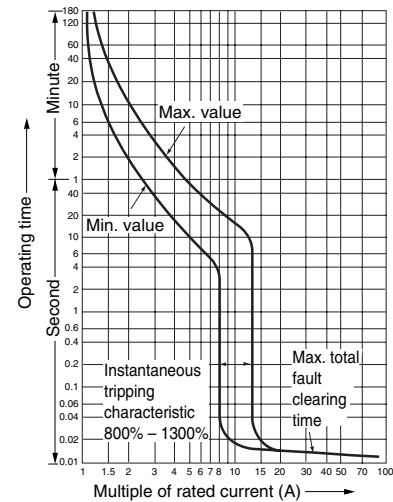

Molded Case Circuit Breakers

Characteristic curves

Line protection

■ H series, 3-pole

H800B, H800R

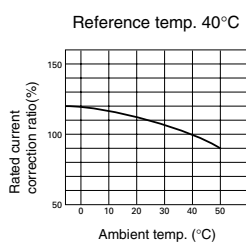
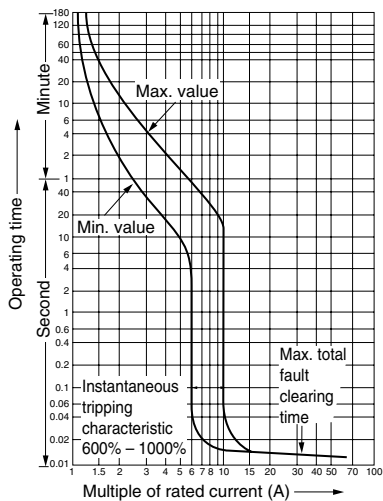

■ S and E series

SA30CM, SA50CM, SA50RCM
EA30ACM, EA50CM

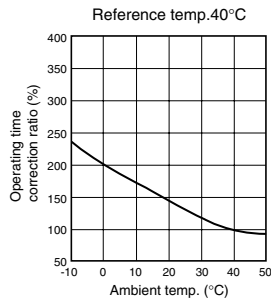
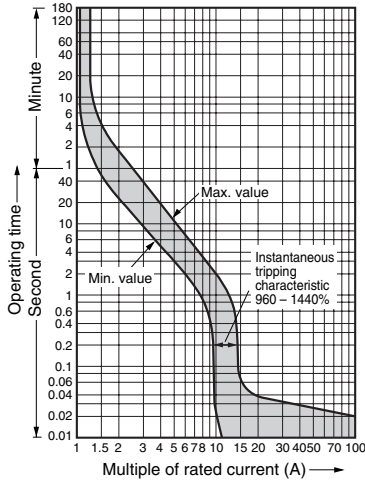

SA225CM, SA225RCM
EA225CM

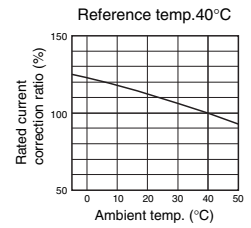
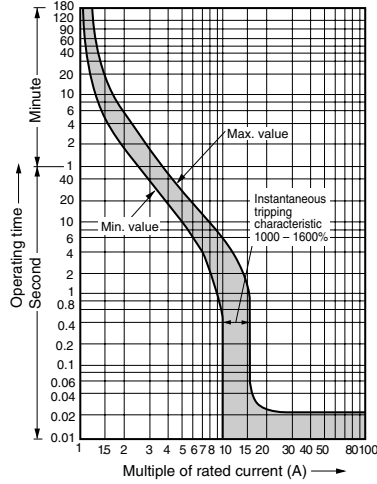

SA60CM
EA60CM, EA100CM

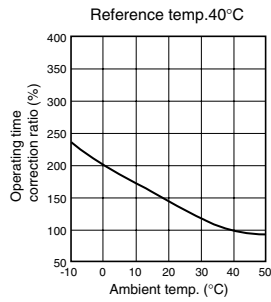
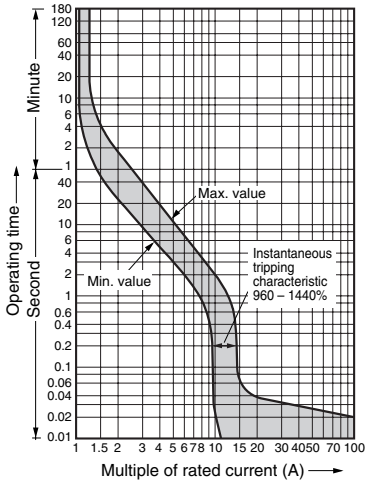

■ L and H series

LA50BM

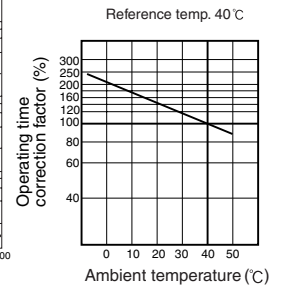
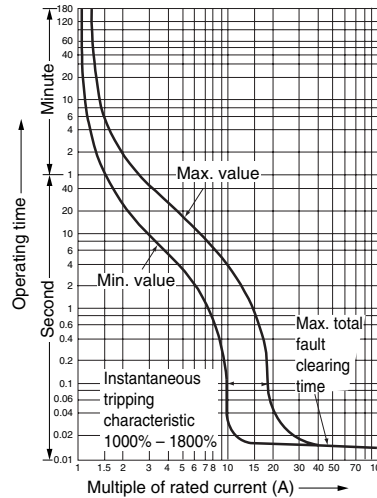

SA100CM, SA100RCM

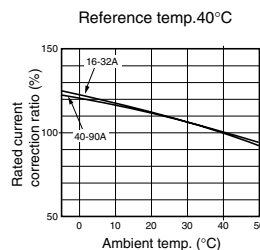
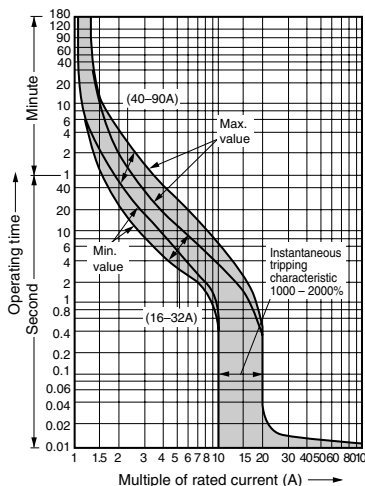

H50BAM

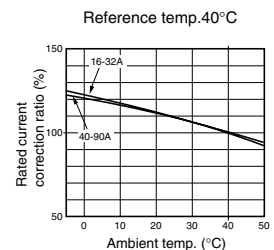
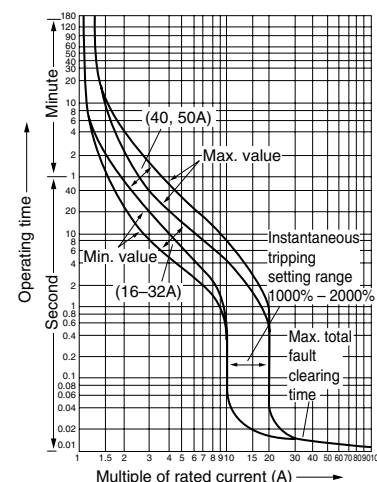

Molded Case Circuit Breakers

Characteristic curves

UL Listed

■ S series, 2, 3-pole

SA50RCUL

Rated current : 5, 10, 40A

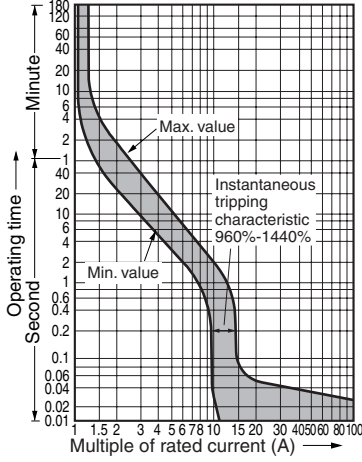

Rated current : 3, 15, 20, 30, 50A

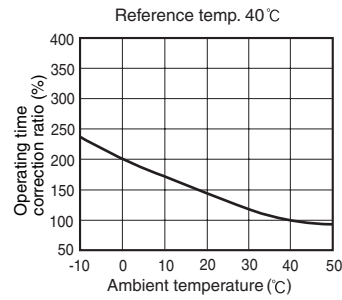
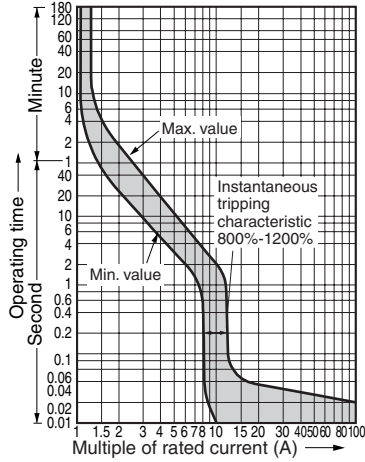

SA100CUL

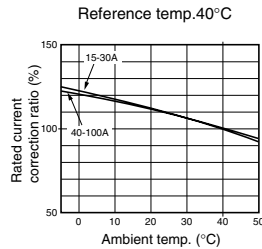
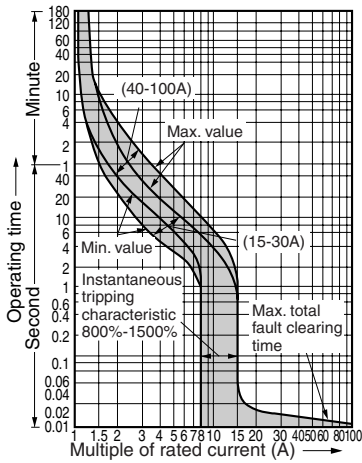

SA100RCUL

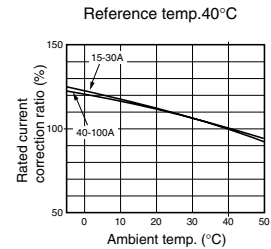
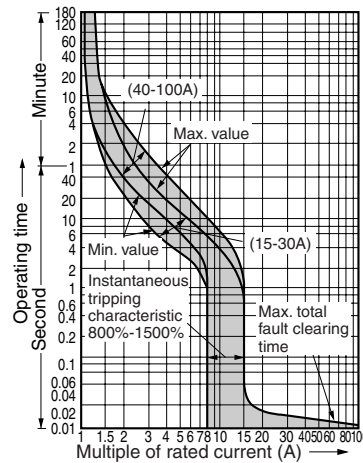

SA225CUL

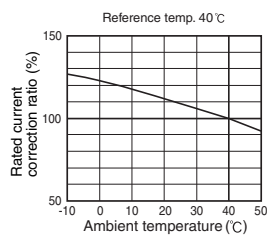
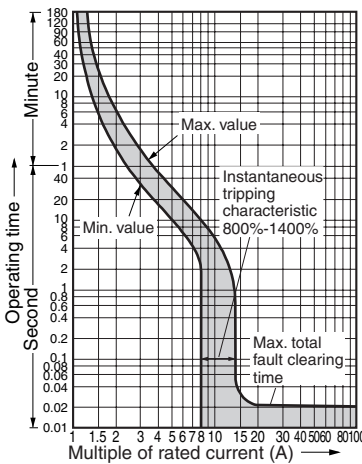

SA225RCUL

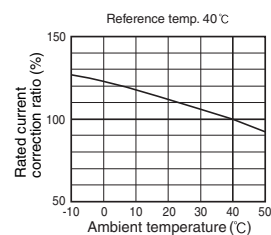
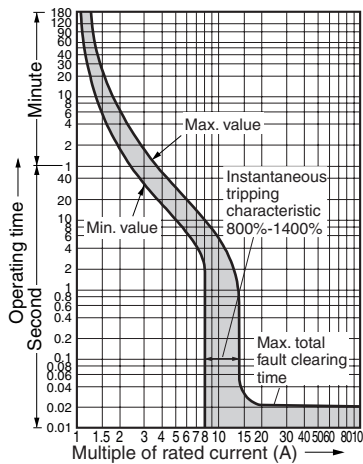

■ S series, 2, 3-pole

SA400CUL

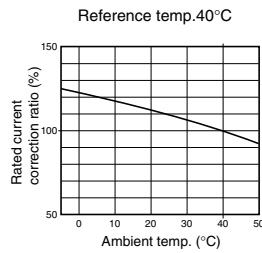
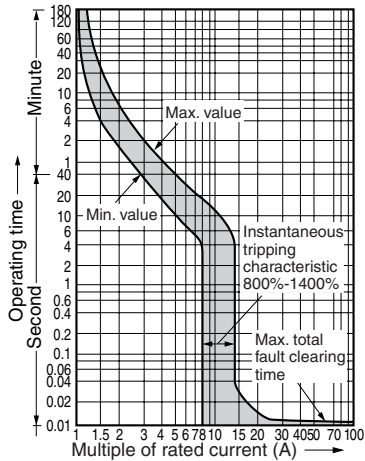

SA400RCUL

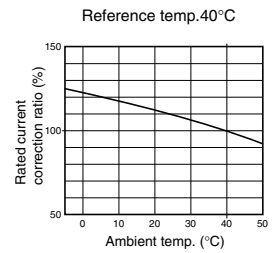
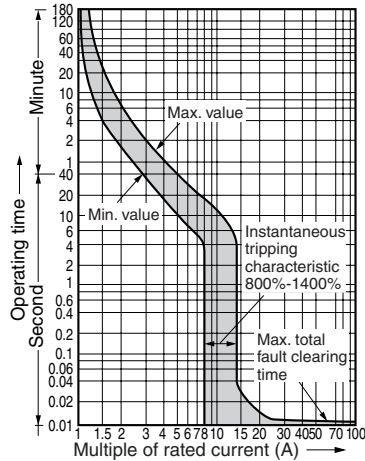

SA600RCUL

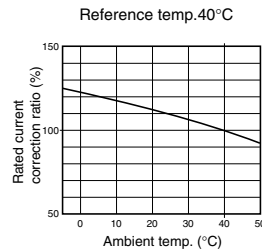
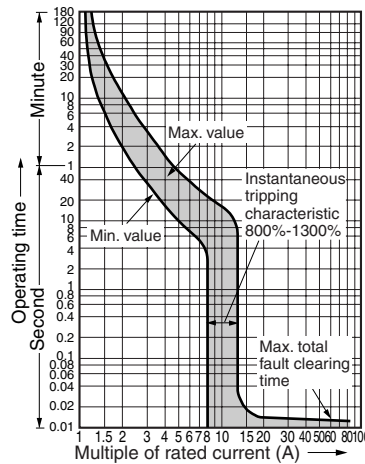

SA800RCUL

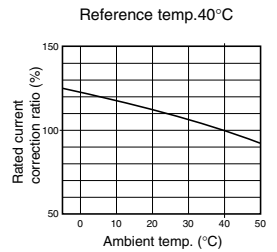
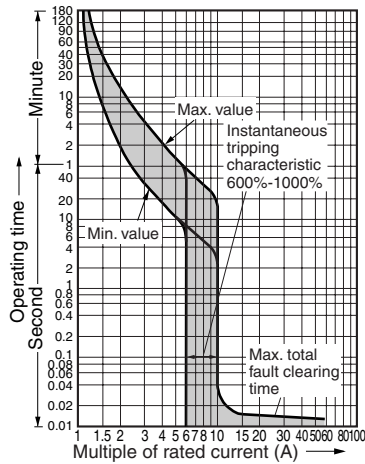

■ E series, 2, 3-pole

EA100CUL

Rated current : 5, 10, 40, 60, 70, 75, 80, 90A

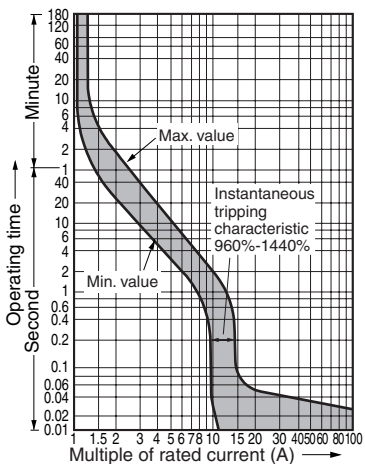

Rated current : 3, 15, 20, 30, 50, 100A

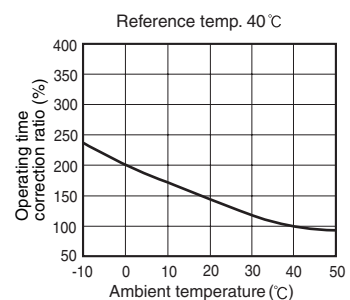
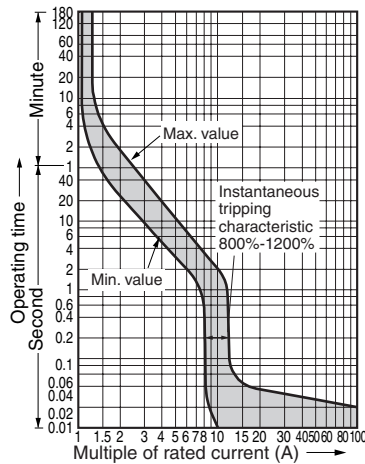

Molded Case Circuit Breakers Accessories

Variation of internal accessory

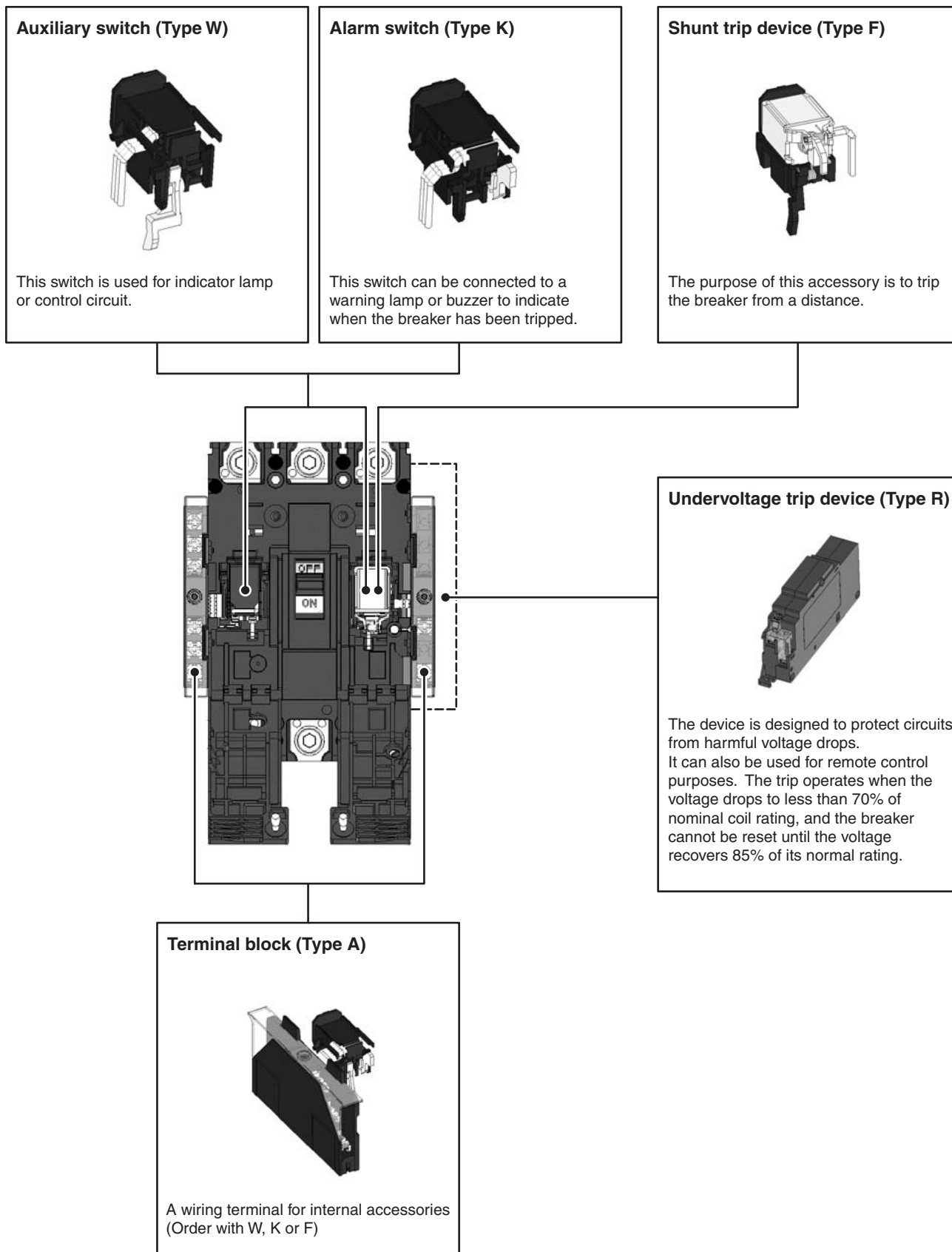

Variation of external accessory

Insulation barriers

The interphase barrier reinforces the insulation between terminals, while the earth barrier increases the insulation between the terminal and the mounting panel.

[See page 06/129](#)

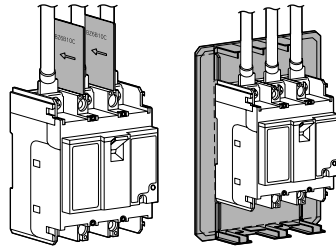

Interface barrier

Earth barrier

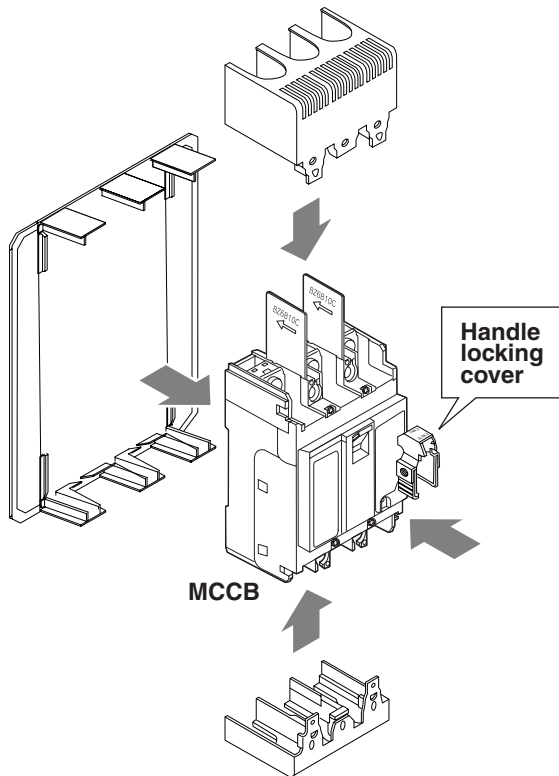

MCCB

Handle locking cover

Mechanical interlock device

The mechanical interlock device can be mounted onto two separate breakers to maintain a mutual ON or OFF condition. The device can also be locked with a padlock.

[See page 06/110](#)

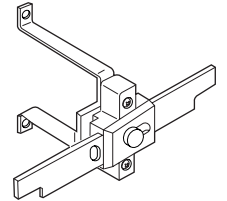

External operating handles

There are two handles available in the series: the V type handle on panel mount and the N type handle on breaker mount. An extension shaft (sold separately) for the V type handle allows the distance between the handle and the breaker to be adjusted. The protective structure of the V type handle operation section conforms to IP54. Both handle types can be locked with a padlock conforming to IEC 60204-1. The panel cutout dimensions are the same for both handles.

[See page 06/113](#)

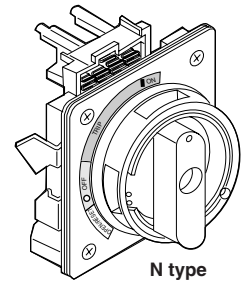

N type

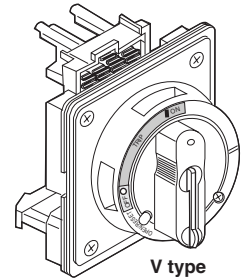

V type

Motor-operating mechanism

A new drive structure in the motor operating mechanism speeds up drive operation to drastically reduce ON/OFF switching time from 2s to 0.1s.

[See page 06/106](#)

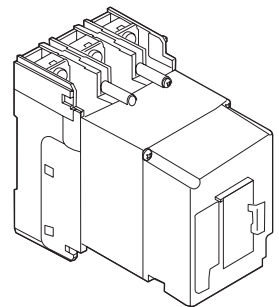

Terminal covers

Finger protection guards against shock from accidentally touching live terminals.

Two types of terminal covers are available—long type and short type.

[See page 06/128](#)

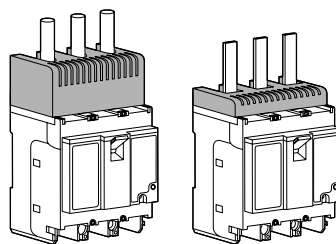

Long type

Short type

Steel enclosures

Enclosures are available in three types—two with V-type handle which allows the operation from the outside, and other direct operating.

[See page 06/126](#)

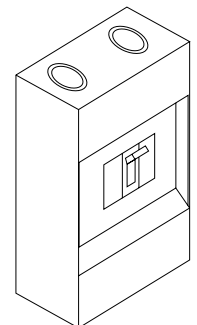

Molded Case Circuit Breakers

Internal accessories

Terminal blocks

Terminal blocks for auxiliary circuit

- It indicates the terminal No. of internal accessory. The connection method of internal accessory is lead-wire system and terminal block system.
- Specify the connection method when ordering. It is lead-wire system unless specified.
- The lead wires are pulled out and terminal blocks are attached on the same side of the internal accessory will be attached
- For the available configuration of internal accessory, see page [06/92 to 06/93](#).

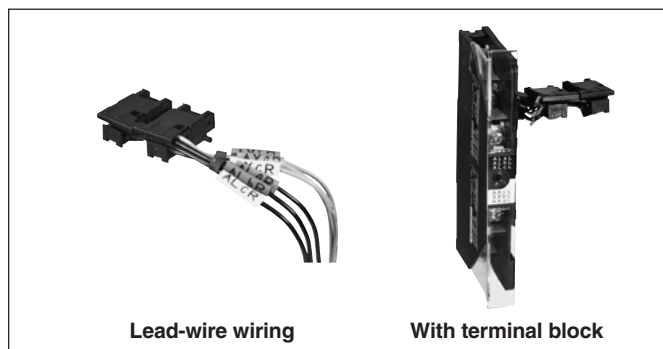

• IEC and CE marking conformed types

Accessory		30 – 225AF		400 – 800AF
		Left side mounting	Right side mounting	Left side mounting
Auxiliary switch	SPDT: W			
	2PDT: W2			
Alarm switch	SPDT: K			
	2PDT: K2			
Shunt trip device : F	With 1NO contact to prevent coil burn-out			
	Continuous rating			
Undervoltage trip device : R				

• L series, H series

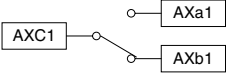
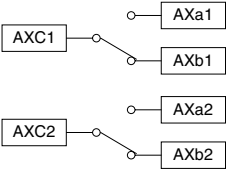
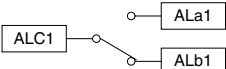
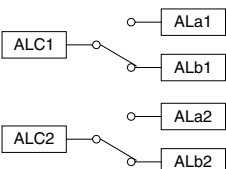
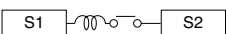
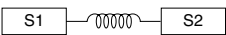
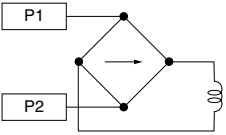
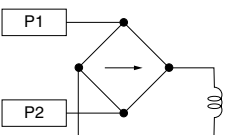
Accessory		Terminal number
		LA50B, H100R, H225R, H400R, H600R, H800R H50BA, H100BA, H225BA, H400B, H600B, H800B
Auxiliary switch	SPDT: W	
	2PDT: W2	
Alarm switch	SPDT: K	
	2PDT: K2	
Shunt trip device : F	With 1NO contact to prevent coil burn-out	
	Continuous rating	
Undervoltage trip device : R	AC LA50B, H50BA H100R, H100BA H225R, H225BA H400R, H400B H600R, H600B H800R, H800B	
	DC LA50B, H50BA H100R, H100BA H225R, H225BA H400R, H400B H600R, H600B H800R, H800B	

Molded Case Circuit Breakers

Internal accessories

Available configurations

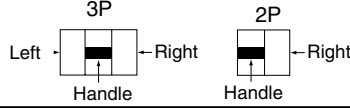

Undervoltage trip: R
 Shunt trip: F
 Auxiliary switch: W
 Alarm switch: K

MCCB	S series	SA32C SA52C SA52RC SA62C SA62RC	SA102C	SA33C SA53C SA53RC SA63C SA63RC	SA103C SA102RC SA103RC SA202C SA203C SA202RC SA203RC	—	SA402C SA403C SA402RC SA403RC SA603RC SA803RC	SA54B*1 SA104R SA204R	SA404HA	SA604H SA804H
	E series	EA32AC EA52AC EA52C EA62C EA102C	—	EA33AC EA53AC EA53C, 63C EA103AC EA103C	EA202C EA203C	—	EA402C EA403C EA603C EA803C	EA104B *1	—	—
	H • L series	—	—	—	—	LA53B H103R, 203R H52BA, 53BA H102BA, 103BA H202BA, 203BA	H402B, H403B H403R H603B, H603R H803B, H803R *3	—	—	—
Pole	2	2	3	2, 3	2, 3	2, 3	2, 3	4	4	4
Auxiliary switch SPDT W										
Alarm switch SPDT K										
Shunt trip F										
Undervoltage trip R										
W2										
W+K										
W2+K										
K2										
W+K2										
W2+K2										
W+F										
W2+F										
W+R										
W2+R										
K+F										
K+R										
W+K+F										
W+K+R										
K2+F										
K2+R										
W2+K+F										
W2+K+R										
W+K2+F										
W+K2+R										
W2+K2+F										
W2+K2+R										

Notes: • The lead wires are pulled out and terminal blocks are attached on the same side of the accessory attached.
 *1 The "W" and "K" of EA104B and SA54B are mounted on the left pole only. They cannot be mounted on the right side pole.
 *2 The side on which the undervoltage trip device "R" is mounted has the terminal block.
 *3 H400R, H600R, H800R: Factory-mounted

■ Available configurations

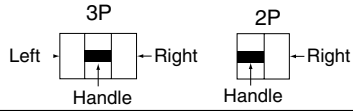

■ Undervoltage trip: R □ Shunt trip: F ○ Auxiliary switch: W ● Alarm switch: K

MCCB	S series	SA52RCUL *	SA53RCUL *	SA102CUL SA103CUL SA102RCUL SA103RCUL SA202CUL SA203CUL SA202RCUL SA203RCUL	SA402CUL SA403CUL SA402RCUL SA403RCUL SA603RCUL SA803RCUL
	E series	EA102CUL *	EA103CUL *	-	-
Pole	2	3	2, 3	2, 3	
Auxiliary switch SPDT W					
Alarm switch SPDT K					
Shunt trip F					
Undervoltage trip R					
W2					
W+K					
W2+K					
K2					
W+K2					
W2+K2					
W+F					
W2+F					
W+R					
W2+R					
K+F					
K+R					
W+K+F					
W+K+R					
K2+F					
K2+R					
W2+K+F					
W2+K+R					
W+K2+F					
W+K2+R					
W2+K2+F					
W2+K2+R					

Notes: ● The lead wires are pulled out and terminal blocks are attached on the same side of the accessory attached.
* Terminal block connection is standard method

Molded Case Circuit Breakers

Internal accessories

■ Type number nomenclature of internal accessory

• Up to 225AF

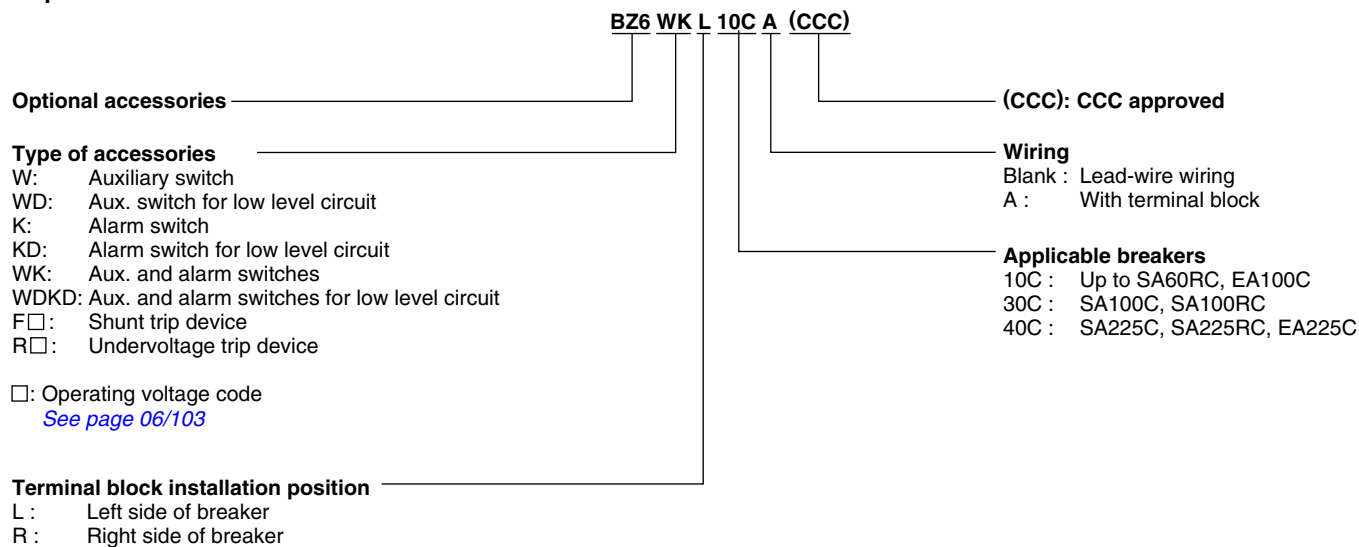

• 400AF to 800AF

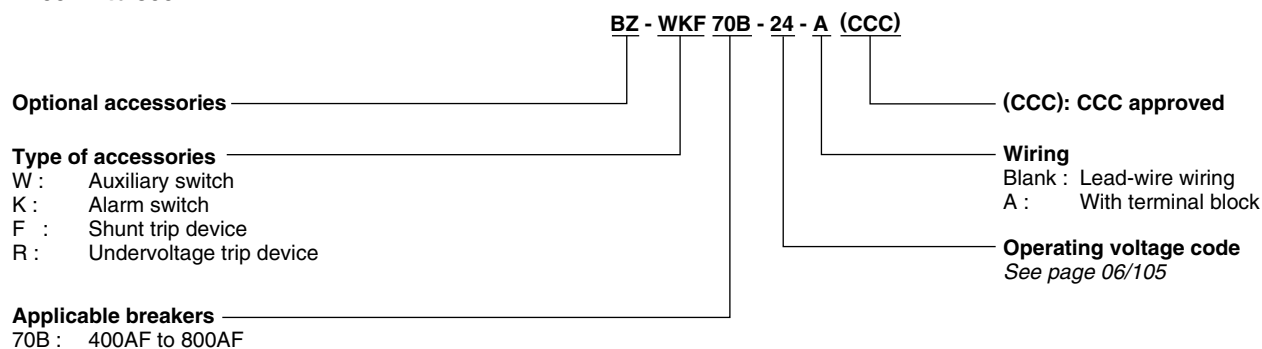

■ Operation of auxiliary switches(W) and alarm switches(K)

Accessory	Handle position		Trip
	ON	OFF	
Auxiliary switch	SPDT: W		
	2PDT: W2		
Alarm switch	SPDT: K		
	2PDT: K2		
For L series H series	Auxiliary switch		
	SPDT: W		
	2PDT: W2		
Alarm switch			
SPDT: K			
2PDT: K2			

Note: Ring mark indication

06

Molded Case Circuit Breakers

Internal accessories

■ Ratings of auxiliary switches(W) and alarm switches(K)

● Standard type

Applicable breaker type			AC			DC			Minimum load current
S series	E series	H and L series	Voltage (V)	Make/break current (A)		Voltage (V)	Make/break current (A)		
				Res. load	Ind. load		Res. load	Ind. load	
SA30C SA50C SA50RC SA60C SA60RC	EA30AC EA50AC EA50C EA60C EA100AC EA100C	—	125	5 (5)	4 (5)	30	3 (3)	2 (3)	5V DC 160mA 30V DC 30mA
			250	5 (5)	4 (5)	125	0.6 (0.6)	0.4 (0.6)	
						250	0.3 (0.3)	0.2 (0.3)	
—	—	LA50B, H50BA	125	5 (3)	4 (2)	30	3 (2)	2 (1)	
		H100BA, H100R	250	5 (2)	4 (1)	125	0.4 (0.4)	0.2 (0.1)	
		H225BA, H225R	500	2	1	250	0.2	0.1	
SA100C SA100RC SA225C SA225RC	EA225C	—	125	5 (2)	2 (2)	30	4 (1)	3 (1)	
			250	3 (1)	1 (1)	125	0.4 (0.5)	0.4 (0.5)	
						250	0.2 (0.2)	0.2 (0.2)	
SA400C SA400RC SA600RC SA800RC	EA400C EA600C EA800C	H400B H400R H600B H600R H800B H800R	125	5	4	30	3	2	
			250	5	4	125	0.4	0.2	
			500	2	1	250	0.2	0.1	

Note: () Rep. value for IEC60941-5-1 or JIS C8201-5-1

● Low level circuit

Applicable breaker type			DC		Minimum load current
S series	E series	H and L series	Voltage (V)	Make/break current (A)	
SA30C SA50C SA50RC SA60C SA60RC	EA30AC EA50AC EA50C EA60C EA100AC EA100C	—	30	0.1	5V DC 1mA 30V DC 1mA
SA100C SA100RC SA225C SA225RC	EA225C	—	30	0.1	
SA400C SA400RC SA600RC SA800RC	EA400C EA600C EA800C	—	30	0.1	
—	—	H50BA, LA50B H100BA, H100R H225BA, H225R H400B, H400R H600B, H600R H800B, H800R	30	0.1 (Res. load)	

■ Operation of auxiliary switches(W) and alarm switches(K)

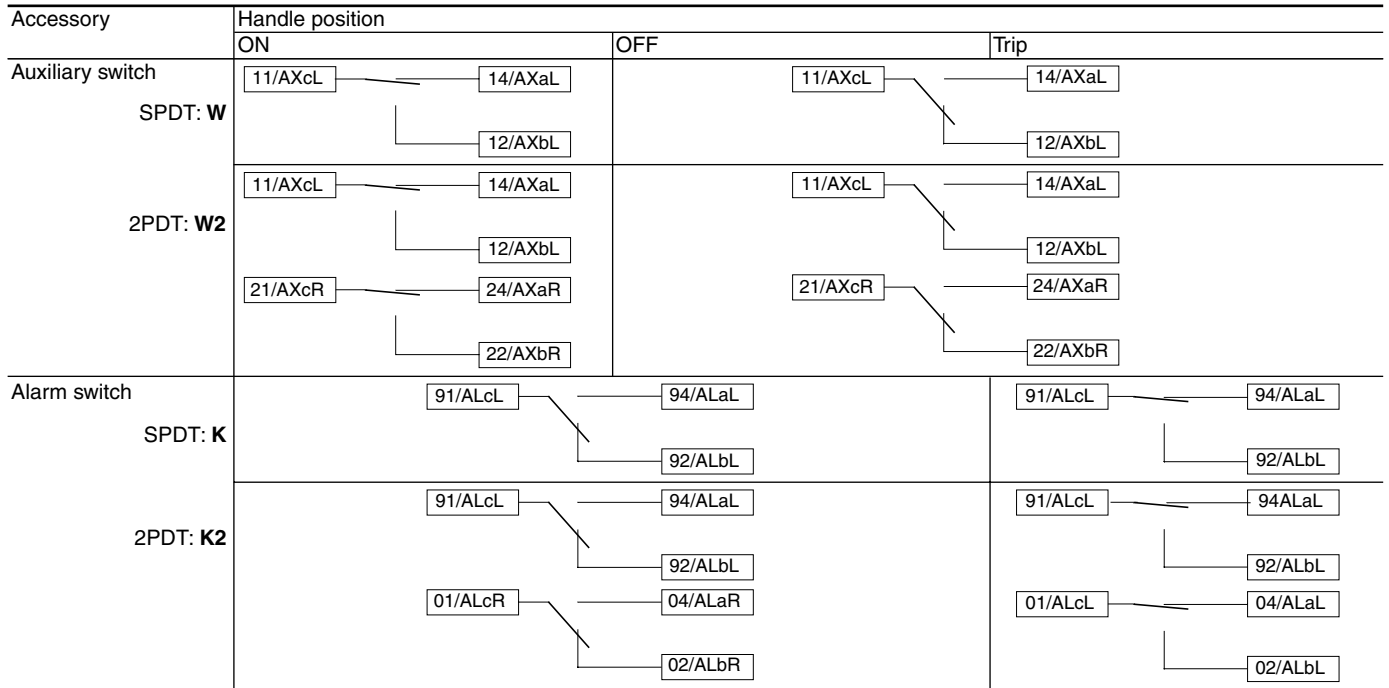

Note: Ring mark indication

06

■ Ratings of auxiliary switches(W) and alarm switches(K)

● Standard type

MCCB		AC		DC		Minimum load current
S series	E series	Voltage (V)	Make/break current (A)	Voltage (V)	Make/break current (A)	
SA50RCUL	EA100CUL	120	3.6	125	0.55	5V DC 160mA 30V DC 30mA
		240	1.8	250	0.27	
SA100CUL SA100RCUL SA225CUL SA225RCUL	—	120	5	—	—	
		240	3			
SA400CUL SA400RCUL SA600RCUL SA800RCUL	—	120	5	—	—	
		240	5			

● Low level circuit

MCCB		DC		Minimum load current
S series	E series	Voltage (V)	Make/break current (A)	
SA50RCUL	EA100CUL	30	0.1	5V DC 1mA 30V DC 1mA
SA100CUL SA100RCUL SA225CUL SA225RCUL	—	30	0.1	
SA400CUL SA400RCUL SA600RCUL SA800RCUL	—	30	0.1	

Molded Case Circuit Breakers

Internal accessories

■ Rating of shunt trip (F)

- IEC and CE marking conformed

MCCB type			Power consumption				Time rating of coil	Operating time (ms)		
S series	E series	H and L series	AC		DC					
			V	VA	V	W				
SA30C SA50C SA50RC SA60C SA60RC	EA30AC EA50AC EA50C EA60C EA100AC EA100C	–	100-120 (50/60Hz) 200-240 (50/60Hz) 380-450 (50/60Hz)	150 150 200	100-110 – –	150 – –	Continuous (With 1NO contact to prevent coil burn-out)	7-13		
SA100C SA100RC SA225C SA225RC	EA225C	H50BA LA50B H100BA H100R H225BA H225R	24 (50/60Hz) 48 (50/60Hz) 100-125 (50/60Hz) 200-240 (50/60Hz) 380-450 (50/60Hz) 440-480 (50/60Hz)	30	24 48 100-110 200-220 – –	35			Continuous (With 1NO contact to prevent coil burn-out)	7-21
SA400C SA400RC SA600RC SA800RC	EA400C EA600C EA800C	H400B H400R H600B H600R H800B H800R	24-48 (50/60Hz) 100-240 (50/60Hz) 380-550 (50/60Hz)	2 3 4	24-48 100-220 –	2 3 –				

Note: Allowable voltage function AC voltage: 85% to 110% of coil rated voltage
DC voltage: 75% to 125% of coil rated voltage

● UL Listed

MCCB type			Power consumption				Time rating of coil	Operating time (ms)		
S series	E series	H and L series	AC		DC					
			V	VA	V	W				
SA50RCUL	EA100CUL	–	100-120 (50/60Hz) 200-240 (50/60Hz) 380-450 (50/60Hz)	150 150 200	100-110 – –	150 – –	Continuous (With 1NO contact to prevent coil burn-out)	7-13		
SA100CUL SA100RCUL SA225CUL SA225RCUL	–	–	24 (50/60Hz) 48 (50/60Hz) 100-125 (50/60Hz) 200-240 (50/60Hz)	30	24 48 100-110 200-220	35			Continuous	7-21
SA400CUL SA400RCUL SA600RCUL SA800RCUL	–	–	24-48 (50/60Hz) 100-240 (50/60Hz)	2 3	24-48 100-220	2 3				

Note: Allowable voltage function AC voltage: 85% to 110% of coil rated voltage
DC voltage: 75% to 125% of coil rated voltage

■ Rating of undervoltage trip (R)

- IEC and CE marking conformed

MCCB type			Power consumption				Operating voltage
S series	E series	H and L series	AC		DC		
			V	VA	V	W	
SA30C	EA30AC	-	100(50Hz)/100-110(60Hz)	2.8	-	-	Tripping voltage: 70 to 35% of coil rating voltage
SA50C	EA50AC		200(50Hz)/200-220(60Hz)	3.4	-	-	
SA50RC	EA50C		400(50Hz)/400-440(60Hz)	4.4	-	-	
SA60C	EA60C		-	-	100-110	2.86	
SA60RC	EA100AC EA100C						Closing voltage: 85% or more of coil rating voltage
SA100C	EA225C	H50C	100(50Hz)/100-110(60Hz)	200	-	-	
SA100RC		H100C	200(50Hz)/200-220(60Hz)	150	-	-	
SA225C		H225C	400(50Hz)/400-440(60Hz)	200	-	-	
SA225RC		-	-	-	100-110	200	
-	-	LA50B * ¹	24 (50/60Hz)	0.76	24	0.76	
		H 50BA * ¹	48 (50/60Hz)	1.5	48	1.5	
		H100BA * ¹	100-110 (50/60Hz)	3.5	100-110	3.5	
		H100R * ¹	200-220 (50/60Hz)	2.0	200-220	2.0	
		H225BA * ¹	380-440 (50/60Hz)	2.9	-	-	
		H225R * ¹	440-480 (50/60Hz)	4.3	-	-	
SA400C	EA400C EA600C EA800C	H400B	24 (50/60Hz)	2	24	2	
SA400RC		H400R	48 (50/60Hz)	2	48	2	
SA600RC		H600B	100-110 (50/60Hz)	3	100-110	3	
SA800RC		H600R	200-240 (50/60Hz)	3	200-220	3	
		H800B	380-480 (50/60Hz)	4	-	-	
		H800R					

Notes: • Specify the operating voltage when ordering.
*¹ Terminal block connection is standard method.

06

● UL type

MCCB type			Power consumption				Operating voltage
S series	E series	H and L series	AC		DC		
			V	VA	V	W	
SA50RCUL	EA100CUL	-	100(50Hz)/100-110(60Hz)	3	-	-	Tripping voltage: 70 to 35% of coil rating voltage
			200(50Hz)/200-220(60Hz)	3	-	-	
			400(50Hz)/400-440(60Hz)	4	-	-	
SA100CUL	-	-	-	-	100-110	200	Closing voltage: 85% or more of coil rating voltage
SA100RCUL			100(50Hz)/100-110(60Hz)	200	-	-	
SA225CUL			200(50Hz)/200-220(60Hz)	150	-	-	
SA225RCUL			400(50Hz)/400-440(60Hz)	200	-	-	
SA400CUL	-	-	24 (50/60Hz)	2	24	2	
SA400RCUL			48 (50/60Hz)	2	48	2	
SA600RCUL			100-110 (50/60Hz)	3	100-110	3	
SA800RCUL			200-240 (50/60Hz)	3	200-220	3	

Molded Case Circuit Breakers

Internal accessories

■ Dimensions, mm

Shunt trip device "F" and undervoltage trip device "R"

S series	E series	Fig.	Mass (kg)
SA30C SA50C, SA50RC SA60C, SA60RC	EA30AC EA50AC, EA50C EA60C EA100AC, EA100C	Fig.1	0.15
SA100C, SA100RC	—	Fig.2	0.17
SA225C, SA225RC	EA225C	Fig.3	

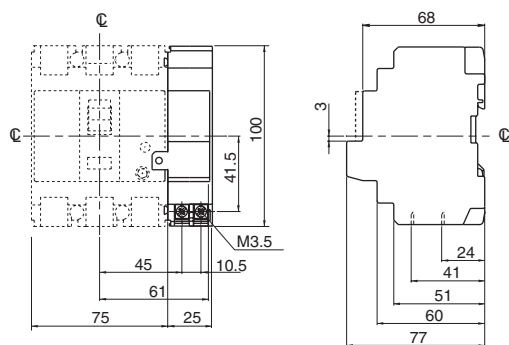

Fig.1

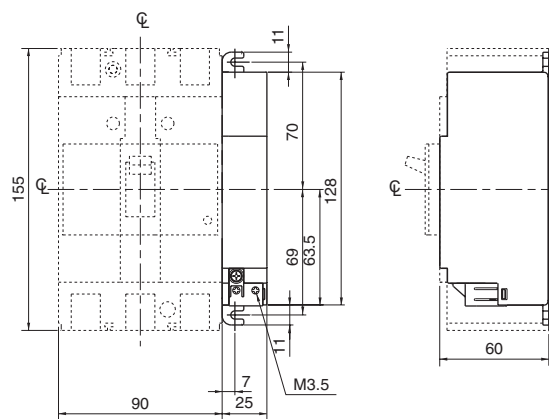

Fig.2

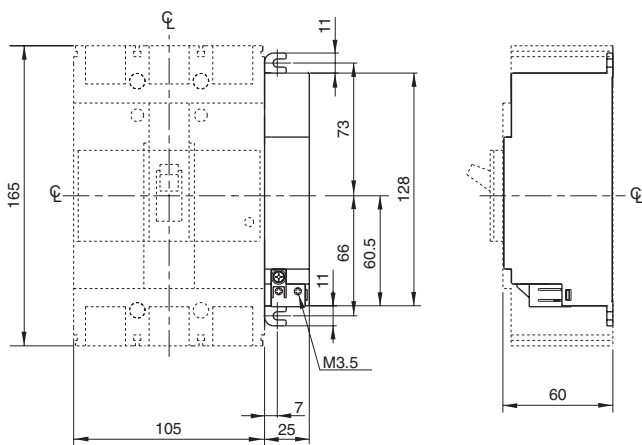

Fig.3

Molded Case Circuit Breakers

Internal accessories

■ Type number

● Auxiliary switches (W) and alarm switches (K)

MCCB type		Type number									
S series	E series	Auxiliary switch / W		Alarm switch / K		Auxiliary switch + Alarm switch / WK					
		SPDT: W	Mass(kg)	2PDT: W2	Mass(kg)	SPDT: K	Mass(kg)	2PDT: K2	Mass(kg)		
SA30C *	EA30AC *	BZ6W□10C	0.01	–	–	BZ6K□10C	0.01	–	–	BZ6WK□10C	0.02
SA50C *	EA50AC *	BZ6W□10CA	0.04	–	–	BZ6K□10CA	0.04	–	–	BZ6WK□10CA	0.08
SA50RC *	EA50C *	(With terminal block)				(With terminal block)				(With terminal block)	
SA60C *	EA60C *										
SA60RC *	EA100AC *										
	EA100C *										
SA100C	–	BZ6W□30C	0.02	–	–	BZ6K□30C	0.02	–	–	BZ6WK□30C	0.04
SA100RC		BZ6W□30CA	0.05	–	–	BZ6K□30CA	0.05	–	–	BZ6WK□30CA	0.07
		(With terminal block)				(With terminal block)				(With terminal block)	
SA225C	EA225C	BZ6W□40C	0.02	–	–	BZ6K□40C	0.02	–	–	BZ6WK□40C	0.04
SA225RC		BZ6W□40CA	0.05	–	–	BZ6K□40CA	0.05	–	–	BZ6WK□40CA	0.07
		(With terminal block)				(With terminal block)				(With terminal block)	
SA400C	EA400C	BZ-W70B	0.02	BZ-W270B	0.04	BZ-K70B	0.02	BZ-K270B	0.04	BZ-WK70B	0.04
SA400RC	EA600C	BZ-W70B-A	0.11	BZ-W270B-A	0.22	BZ-K70B-A	0.11	BZ-K270B-A	0.22	BZ-WK70B-A	0.03
SA600RC	EA800C	(With terminal block)		(With terminal block)		(With terminal block)		(With terminal block)		(With terminal block)	
SA800RC											

MCCB type		Type number			
L series	H series	Auxiliary switch / W		Alarm switch / K	Auxiliary switch + Alarm switch / WK
		SPDT: W		SPDT: K	
LA50B	–	BZ-W23B□		BZ-K23B□	BZ-WK23B□
–	H50B H100BA	BZ-W35B□		BZ-K35B□	BZ-WK35B□
–	H225BA	BZ-W40B□		BZ-K40B□	BZ-WK40B□
–	H100R H225R	BZ-W50B□		BZ-K50B□	BZ-WK50B□
–	H400B H600B H800B	BZ-W70B□		BZ-K70B□	BZ-WK70B□

● UL Listed

MCCB type		Type number			
S series	E series	Auxiliary switch / W		Alarm switch / K	Auxiliary switch + Alarm switch / WK
		SPDT: W		SPDT: K	
SA50RCUL	EA100CUL	BZ6W□10CU BZ6W□10CAU (With terminal block)		BZ6K□10CU BZ6K□10CAU (With terminal block)	BZ6WK□10CU BZ6WK□10CAU (With terminal block)
SA100CUL SA100RCUL	–	BZ6W□30CU BZ6W□30CAU (With terminal block)		BZ6K□30CU BZ6K□30CAU (With terminal block)	–
SA225CUL SA225RCUL	–	BZ6W□40CU BZ6W□40CAU (With terminal block)		BZ6K□40CU BZ6K□40CAU (With terminal block)	–
SA400CUL SA600CUL SA800CUL	–	▲ ▲		▲ ▲	–

Notes: • Auxiliary switch and alarm switch for low level circuit are also available on request, in this case add **D** to the type number when ordering. Example: WD, KD
 • Replace the □ mark by the **R** when an auxiliary switch or an alarm switch is mounted on right hand side of the breaker. Enter the **L** when it is mounted on left hand side of the breaker.
 * 2-pole types are mountable on right side only.

▲ Factory-mounted accessory

● Shunt trip devices (F)

MCCB type		Operating voltage		Type number	With terminal block
S series	E series	Code	Voltage		
SA30C	EA30AC	A	100-120V AC 50/60Hz, 100-110V DC	BZ6FA10C	BZ6FA10CA
SA50C	EA50AC	K	200-240V AC 50/60Hz	BZ6FK10C	BZ6FK10CA
SA50RC	EA50C	P	380-450V AC 50/60Hz	BZ6FP10C	BZ6FP10CA
SA60C	EA60C				
SA60RC	EA100AC EA100C				
SA100C	–	R	24V AC 50/60Hz, 24V DC	BZ6FR30C	BZ6FR30CA
SA100RC		S	48V AC 50/60Hz, 48V DC	BZ6FS30C	BZ6FS30CA
		T	100-125V AC 50/60Hz, 100-110V DC	BZ6FT30C	BZ6FT30CA
		U	200-240V AC 50/60Hz, 200-220V DC	BZ6FU30C	BZ6FU30CA
		P	380-450V AC 50/60Hz	BZ6FP30C	BZ6FP30CA
SA225C	EA225C	R	24V AC 50/60Hz, 24V DC	BZ6FR40C	BZ6FR40CA
SA225RC		S	48V AC 50/60Hz, 48V DC	BZ6FS40C	BZ6FS40CA
		T	100-125V AC 50/60Hz, 100-110V DC	BZ6FT40C	BZ6FT40CA
		U	200-240V AC 50/60Hz, 200-220V DC	BZ6FU40C	BZ6FU40CA
		P	380-450V AC 50/60Hz	BZ6FP40C	BZ6FP40CA
SA400C	EA400C	24	24-48V AC 50/60Hz, 24-48V DC	BZ-F70B-24	BZ-F70B-24-A
SA400RC	EA600C	100	100-240V AC 50/60Hz, 100-220V DC	BZ-F70B-100	BZ-F70B-100-A
SA600RC	EA800C	380	380-550V AC 50/60Hz	BZ-F70B-380	BZ-F70B-380-A
SA800RC					

● Undervoltage trip devices (R)

MCCB type		Operating voltage		Type number	Operating voltage
S series	E series	Code	Voltage		
SA30C	EA30AC	2	100V AC 50Hz/100-110V AC 60Hz	BZ6R210C	Tripping voltage: 70 to 35% of coil rated voltage Closing voltage: 85% or more of coil rated voltage
SA50C	EA50AC	1	110V AC 50Hz/110-127V AC 60Hz	BZ6R110C	
SA50RC	EA50C	W	200V AC 50Hz/200-220V AC 60Hz	BZ6RW10C	
SA60C	EA60C	4	220V AC 50Hz/220-240V AC 60Hz	BZ6R410C	
SA60RC	EA100AC EA100C	5	230V AC 50Hz/230-240V AC 60Hz	BZ6R510C	
		8	240V AC 50Hz	BZ6R810C	
		0	380V AC 50Hz/380-415V AC 60Hz	BZ6R010C	
		9	400V AC 50Hz/400-440V AC 60Hz	BZ6R910C	
		F	24V DC	BZ6RF10C	
		T	100-110V DC	BZ6RT10C	
SA100C	EA225C	2	100V AC 50Hz/100-110V AC 60Hz	▲	
SA100RC		4	200V AC 50Hz/200-220V AC 60Hz	▲	
SA225C		C	400V AC 50Hz/400-440V AC 60Hz	▲	
SA225RC		T	100-110V DC	▲	
SA400C	EA400C	R	24V AC 50/60Hz, 24V DC	BZ-R70B-24	
SA400RC	EA600C	S	48V AC 50/60Hz, 48V DC	BZ-R70B-48	
SA600RC	EA800C	X	100-110V AC 50/60Hz, 100-110V DC	BZ-R70B-100	
SA800RC		U	200-240V AC 50/60Hz, 200-220V DC	BZ-R70B-200	
		E	380-480V AC 50/60Hz	BZ-R70B-380	

Notes: • Specify operating voltage with ordering.
• Terminal block

▲ Factory-mounted accessory
When ordering, specify the rated voltage.

Molded Case Circuit Breakers

Internal accessories

● UL Listed Shunt trip devices (F)

MCCB type		Rated voltage	Type number	
S series	E series		Lead wire	With terminal block
SA50RCUL	EA100CUL	100-120V AC 50/60Hz 200-240V AC 50/60Hz 380-450V AC 50/60Hz	BZ6FA10CU BZ6FK10CU BZ6FP10CU	BZ6FA10CAU BZ6FK10CAU BZ6FP10CAU
SA100CUL SA100RCUL	–	100-125V AC 50/60Hz 200-240V AC 50/60Hz	BZ6FT30CU BZ6FU30CU	BZ6FT30CAU BZ6FU30CAU
SA225CUL SA225RCUL	–	100-125V AC 50/60Hz 200-240V AC 50/60Hz	BZ6FT40CU BZ6FU40CU	BZ6FT40CAU BZ6FU40CAU
SA400CUL SA400RCUL SA600RCUL SA800RCUL	–	24V 50/60Hz 48V 50/60Hz 100-240V 50/60Hz	▲ ▲ ▲	

▲ Factory-mounted accessory

● UL Listed Undervoltage trip devices (R)

MCCB type		Rated voltage	Type number	
S series	E series		Lead wire	With terminal block
SA50RCUL	EA100CUL	100V AC 50Hz/100-110V AC 60Hz 200V AC 50Hz/200-220V AC 60Hz 400V AC 50Hz/400-440V AC 60Hz	– – –	BZ6R210CAU BZ6RW10CAU BZ6R910CAU

● Internal accessories (optional) for 400AF to 800AF

Accessory type	Auxiliary switch		Alarm switch		Shunt trip F	Undervoltage trip R	Number of terminal blocks	Mass (kg)	
	W	W2	K	K2				w/lead wire	w/terminal block
BZ-W70B-□	●						1	0.05	0.14
BZ-K70B-□			●				1	0.05	0.14
BZ-F70B-■-□					●		1	0.09	0.18
BZ-R70B-■-□						●	1	0.09	0.18
BZ-W270B-□		●					2	0.07	0.25
BZ-WK70B-□	●		●				1	0.07	0.16
BZ-W2K70B-□		●	●				2	0.09	0.27
BZ-K270B-□				●			2	0.07	0.25
BZ-WK270B-□	●			●			2	0.09	0.27
BZ-W2K270B-□		●	●				2	0.11	0.29
BZ-WF70B-■-□	●				●		1	0.11	0.20
BZ-W2F70B-■-□		●			●		2	0.13	0.31
BZ-WR70B-■-□	●					●	1	0.11	0.20
BZ-W2R70B-■-□		●				●	2	0.13	0.31
BZ-KF70B-■-□			●		●		1	0.11	0.20
BZ-KR70B-■-□			●			●	1	0.11	0.20
BZ-WKF70B-■-□	●		●		●		1	0.13	0.22
BZ-WKR70B-■-□	●		●			●	1	0.13	0.22
BZ-K2F70B-■-□				●	●		2	0.13	0.31
BZ-K2R70B-■-□				●		●	2	0.13	0.31
BZ-W2KF70B-■-□		●	●		●		2	0.15	0.33
BZ-W2KR70B-■-□		●	●			●	2	0.15	0.33
BZ-WK2F70B-■-□	●			●	●		2	0.15	0.33
BZ-WK2R70B-■-□	●			●		●	2	0.15	0.33
BZ-W2K2F70B-■-□		●	●		●		2	0.17	0.35
BZ-W2K2R70B-■-□		●	●			●	2	0.17	0.35

Notes: ● Indicates the mountable accessories.

- Replace the mark ■ by the operating voltage of shunt trip or undervoltage trip device.
- Replace the mark □ by the A suffix for terminal block type, **blank** for lead-wire connection type.

● Operating voltage for 400AF to 800AF

BZ - WKF 70B - 100 - A

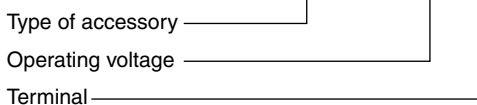

Operating voltage	Shunt trip			Undervoltage trip				
	24/48V AC/DC	100-240V AC 100-220V DC	380-550V AC	24V AC/DC	48V AC/DC	100-110V AC/DC	200-240V AC 200-220V DC	380-480V AC
Code	24	100	380	24	48	100	200	380

■ Ordering information

Specify the following.

1. Type number
2. Lead-wire connection or terminal block type

Molded Case Circuit Breakers

External accessories

Motor-operated breakers

Motor-operated breakers

■ Description

The breaker is fitted with a motor operating mechanism which enables ON, OFF and RESET operations to be carried out electronically by remote control.

4-pole motor operated breakers are also available.



■ Types and ratings

S series	E series	Motor rating			Power source capacity
		Operating voltage	Operating time	Time rating	
SA33C/M SA53C/M, 53RC/M SA63C/M, 63RC/M	EA33AC/M EA53AC/M, 53C/M EA63C/M EA103AC/M, 103C/M	100V DC 100/110V AC 200/220V AC	0.1s	15s per on-off operation	500VA
SA54B/M SA103C/M SA102RC/M, 103RC/M SA104R/M	EA104B/M	24V DC 48V DC 100V DC 100/110V AC 200/220V AC	2s	30s	50VA
SA202C/M, 203C/M SA202RC/M, 203RC/M SA204R/M	EA202C/M, 203C/M		2.5s	30s	50VA
SA402C/M, 403C/M SA402RC/M, 403RC/M SA603RC/M SA803RC/M SA404HA/M	EA402C/M, 403C/M EA603C/M EA803C/M	100/110V DC 100/110V AC 200/220V AC	2s	30s	100VA at 100/110V DC, 100/110V AC 200VA at 200/220V AC
SA604H/M SA804H/M	—		1.5s	30s	1000VA

■ Ordering information

Specify the following:

1. Type number
2. Motor operating voltage

■ Dimensions, mm / Front mounting, front connection

SA33C/M, SA53C/M, SA53RC/M, SA63C/M, SA63RC/M
EA33AC/M, EA53AC/M, EA53C/M, EA63C/M, EA103AC/M, EA103C/M

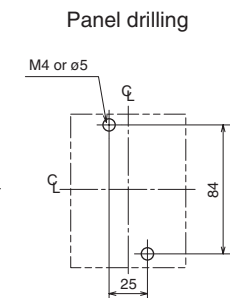
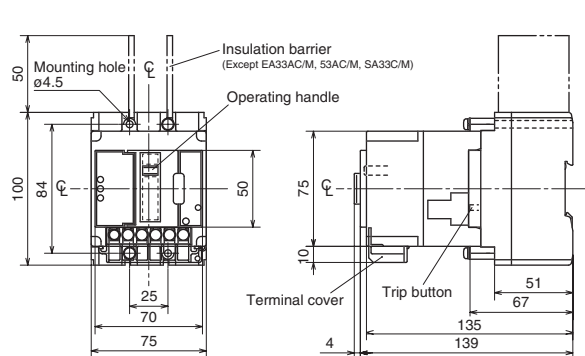

- Notes:
- Trip button operation can be carried out at right side of the breaker.
 - IEC 35mm wide mounting rail is not available.

■ Wiring diagrams

100/110V AC, 200/220V AC, 100V DC

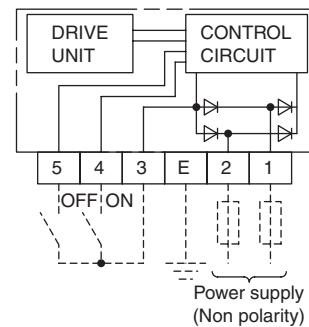

Molded Case Circuit Breakers

External accessories

Motor-operated breakers

■ Dimensions, mm / Front mounting, front connection

SA102RC/M, SA103RC/M, SA103C/M

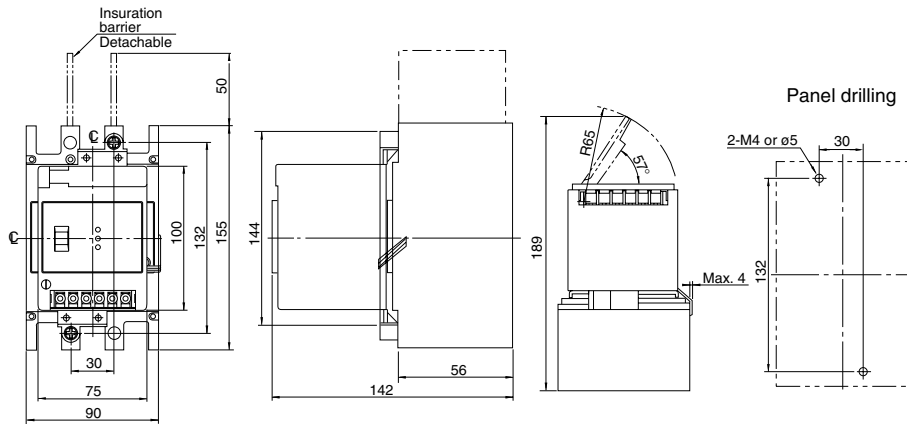

SA202C/M, SA203C/M, SA202RC/M, SA203RC/M
EA202C/M, EA203C/M

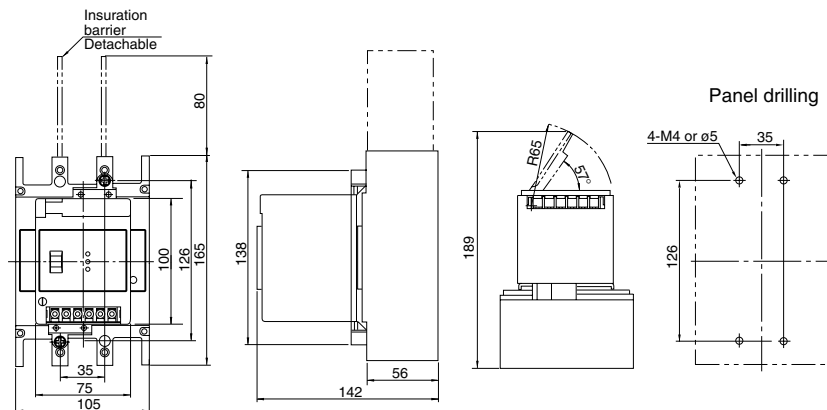

Note: Interphase insulation barriers are standard provided for the front mounting type breakers of 50AF to 225AF.

■ Wiring diagrams

24V DC, 48V DC, 100V DC

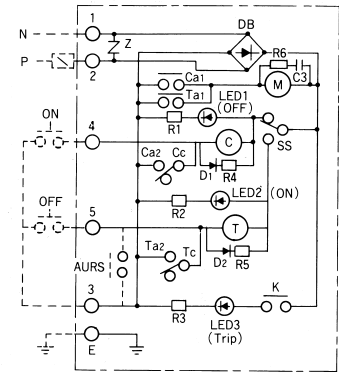

100/110V AC, 200/220V AC

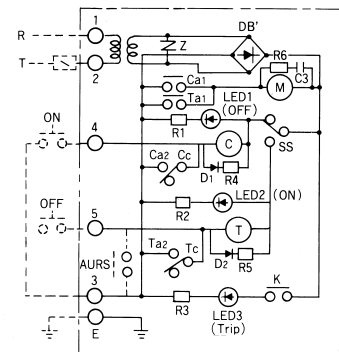

- C : Control relay for breaker closing
- T : Control relay for breaker open
- M : Motor
- Ca1-Cc : Relay terminal number for closing
- Ta1-Tc : Relay terminal number for open
- : Diode
- ⌋ Z : Z-trap (Surge absorber)
- SS : ON/OFF changeover switch
- E, 1-5 : Terminal number for external wire connection
- : Resistor
- ⊕ : LED
- ⬠ : DB (Silicon diode)
- ⊗ : Transformer
- ⊥ : Capacitor
- AURS : Automatic reset switch (supplied on request)

Molded Case Circuit Breakers

External accessories

Motor-operated breakers

Type (MCCB with motor operating mechanism)	Mass (kg)
SA33C/M, SA53C/M, SA53RC/M EA33AC/M, EA53AC/M, EA53C/M	1.2
SA63C/M, SA63RC/M EA63C/M, EA103AC/M, EA103C/M	1.3
SA103C/M, SA102RC/M, SA202RC/M, SA202C/M EA202C/M SA103RC/M	2.1
SA203C/M, SA203RC/M EA203C/M	2.2
SA402C/M, SA402RC/M EA402C/M	2.3
SA403C/M, SA403RC/M, EA403C/M	13.2
SA603RC/M, EA603C/M	14.2
SA803RC/M, EA803C/M	17.5
	18.5

■ Wiring diagrams/400 to 800AF

100/110V AC, 200/220V AC, 50/60Hz

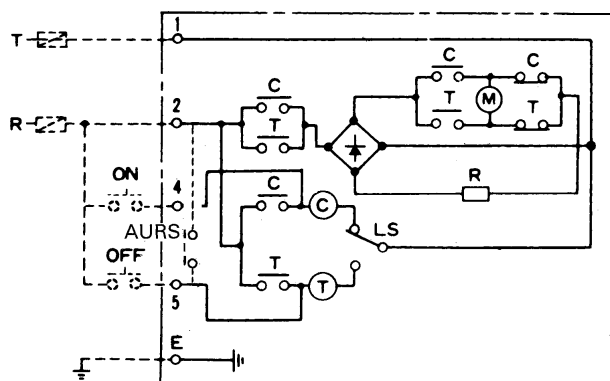

100/110V DC

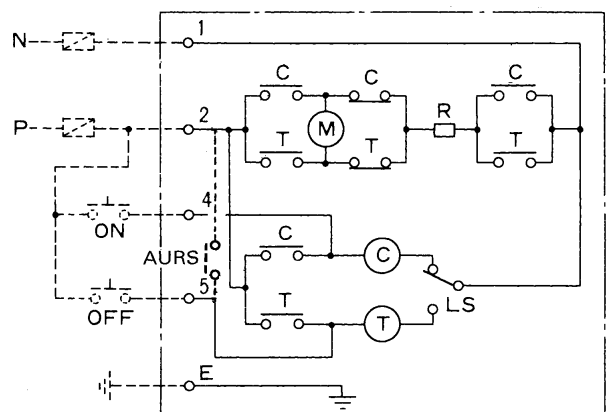

C : Control relay for breaker closing R : Resistor
T : Control relay for breaker open LS : Limit switch
M : Motor
AURS: Automatic reset switch
(supplied on request)

Molded Case Circuit Breakers

External accessories

Mechanical interlocking device

Mechanical interlocking devices

■ Description

These interlocking devices are mounted on the two separate breakers to prevent them from both being closed at the same time.

They employ a slide method and are operated manually.

These interlocking devices is possible to lock with a padlock (not supplied).

They are designed for use when changing over power supplies.

These can be mounted to 3 types of breakers: front-mounting front-connection type, front-mounting rear-connection type (type X), and plug-in mounting type (type P).

Interlock devices for flush mounting type breakers (type E, Y) are also available.

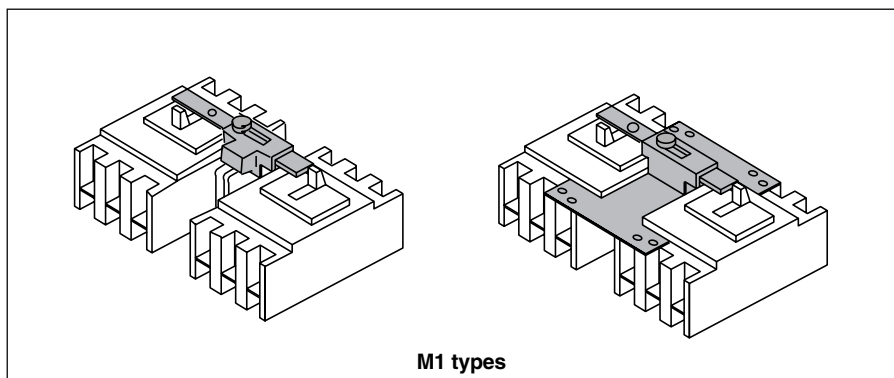

■ Types and applicable breakers

Type	Breaker type	
	S series	E series
BZ6M110C2	SA32C, SA52C, SA52RC SA62C, SA62RC	EA32AC, EA52AC, EA52C EA62C, EA102C
BZ6M110C3	SA33C, SA53C, SA53RC SA63C, SA63RC	EA33AC, EA53AC, EA53C EA63C, EA103AC, EA103C
BZ-M120C-4	SA54B	EA104B
BZ6M130C2	SA102C	–
BZ6M130C3	SA103C SA102RC, SA103RC	–
BZ-M135C-4	SA104R	–
BZ6M140C	SA202C, SA203C SA202RC, SA203RC	EA202C, EA203C
BZ-M150C-4	SA204R	–
BZ-M160C	SA402C, SA403C SA402RC, SA403RC	EA402C, EA403C
BZ-M170C	SA603RC, SA803RC	EA603C, EA803C

Molded Case Circuit Breakers

External accessories

Mechanical interlocking device

■ Dimensions, mm
• 30AF to EA100AF

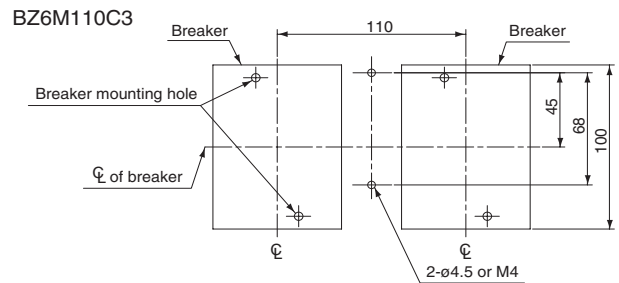
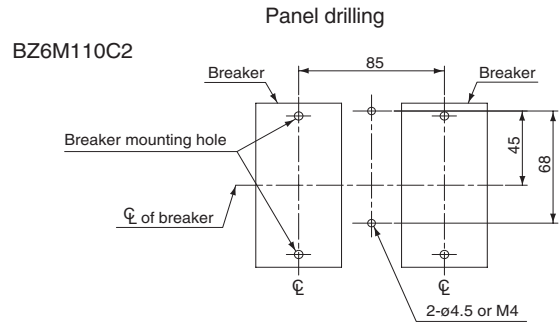
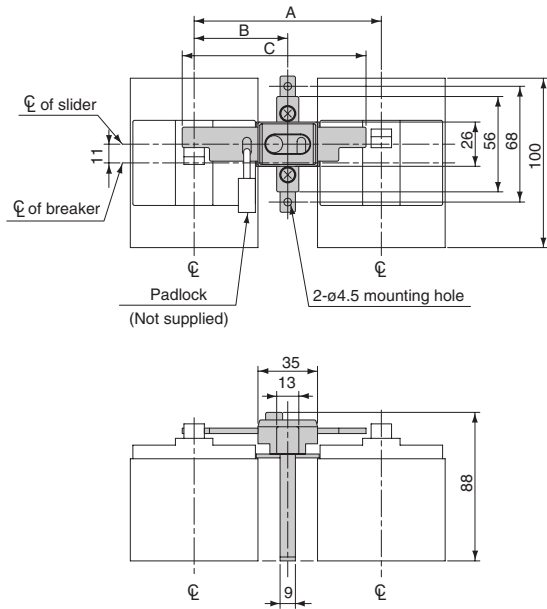

Type	Breaker type		Dimensions, mm			Mass (kg)
	S series	E series	A	B	C	
BZ6M110C2	SA32C	EA32AC	85	42.5	83	0.11
	SA52C	EA52AC				
	SA62C	EA52C				
	SA52RC	EA62C				
	SA62RC	EA102C				
BZ6M110C3	SA33C	EA33AC	110	55	108	0.12
	SA53C	EA53AC				
	SA63C	EA103AC				
	SA53RC	EA53C				
	SA63RC	EA63C EA103C				

Notes: • BZ6M110C2 is not available for padlock.
• Applicable padlock(ø3.5) dimensions, mm

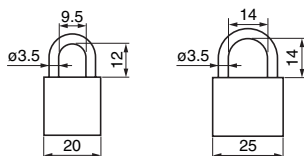

Dimensions for BZ-M120C-4, BZ-M135C-4, BZ-M150C-4: Contact FUJI

Molded Case Circuit Breakers

External accessories

Mechanical interlocking device

■ Dimensions, mm

• SA100AF to SA/EA225AF

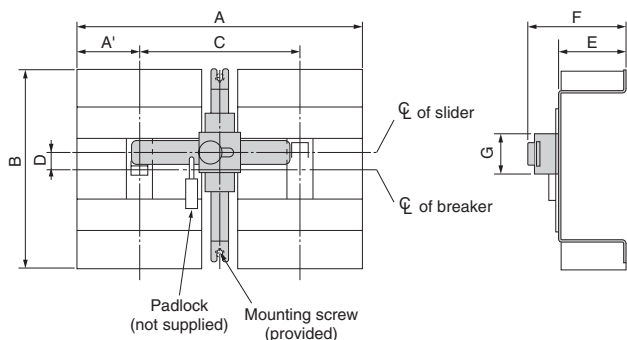

Panel drilling

BZ6M130C2

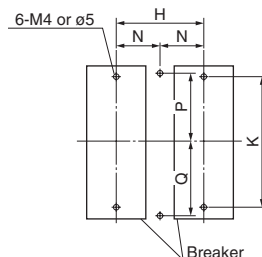

BZ6M130C3

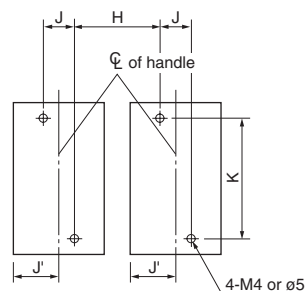

• 400AF to 800AF

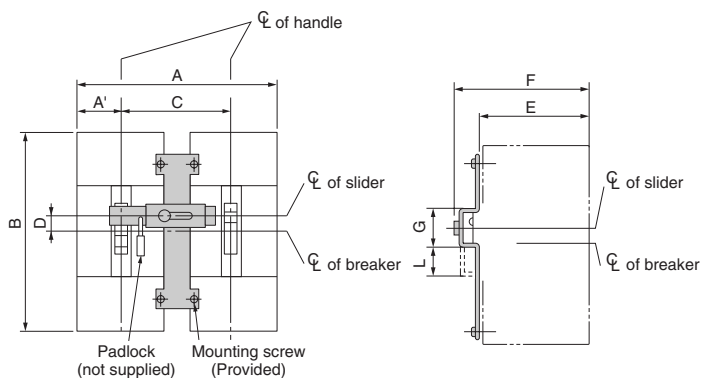

BZ6M140C

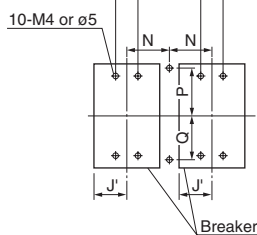

BZ-M160C, M170C, M16

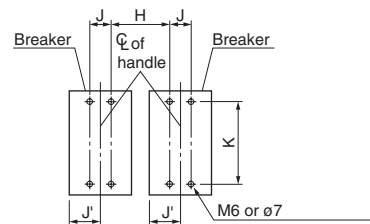

Type	Breaker type		Dimensions, mm													Mass (kg)	
	S series	E series	A (A')	B	C	D	E	F	G	H	J (J')	K	L	N	P		Q
BZ6M130C2	SA102C	—	150 (15)	155	90	9	57.5	85	35	90	—	132	—	45	70	75	0.167
BZ6M130C3	SA103C SA102RC SA103RC	—	210 (45)	155	120	9	57.5	85	35	90	30 (45)	132	—	60	70	75	0.177
BZ6M140C	SA202C SA203C SA202RC SA203RC	EA202C EA203C	240 (52.5)	165	135	14	57.5	85	35	100	35 (52.5)	126	—	67.5	76	69	0.188
BZ-M160C	SA402C SA403C SA402RC SA403RC	EA402C EA403C	355 (70)	257	215	0	94.5	126	54.5	171	44 (70)	215	38	—	—	—	0.56
BZ-M170C	SA603RC SA803RC	EA603C EA803C	500 (105)	275	290	20	94.5	126	54.5	220	70 (105)	243	38	—	—	—	0.64

Note: • Applicable padlock (ø3.5) dimensions, mm

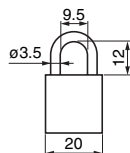

External operating handles

■ **Description**

Molded case circuit breaker handles are generally directly manual-operated but when mounted in motor control centers or on control panels they are sometimes required to be operated externally. To meet such applications FUJI offers the following three types of handles.

N type handle

This type has a knob handle directly attached to the breaker. It is easily fitted by cutting a hole in the panel, which is provided with a door interlock. They may be fitted to all breakers up to 1600 ampere frame sizes. N type handles for SA/EA30AF to EA100AF are approved by UL508.

V type handle

The V type handle may be fitted to breakers of up to 800AF.

A separately sold extension shaft (BZ-VS1) provides distance adjustment between the handle and breaker. Conformed to EN60947-1 isolation function.

Available for EN60204-1 power breaking device.

G type handle

The G type handle is mounted on the panel, and also has a door-interlock. G type handle with a cylinder lock key is also available on request.

G type handle with a padlockable handle lock plate is standard provided for circuit breaker of up to 225AF, and is optional for 400AF and larger.



N type handles BZ-N□C

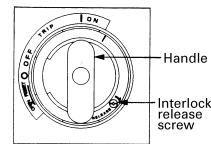
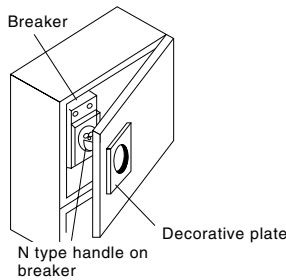

V type handles BZ6V□C

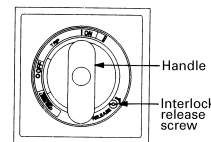
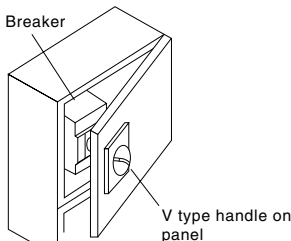

G type handles G-□A

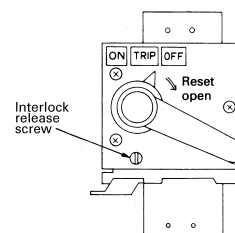
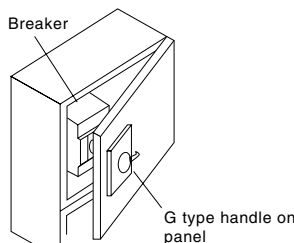

Molded Case Circuit Breakers

External accessories

Operating handles

● For α -TWIN breakers up to 800AF

N type handles

S series	E series	N type handle
SA32C, 33C SA52C, 53C SA52RC, 53RC SA62C, 63C SA62RC, 63RC	EA32AC, 33AC EA52AC, 53AC EA52C, 53C EA62C, 63C EA103AC, 102C, 103C	BZ6N10C UL508 (File No. E216772)
SA102C, 103C SA102RC, 103RC	–	BZ-N30C
SA202C, 203C SA202RC, 203RC	EA202C, 203C	BZ-N40C
SA402C, 403C SA402RC, 403RC	EA402C, 403C	BZ-N60C
SA603RC, 803RC	EA603C, 803C	BZ-N70C

S series	E series	N type handle UL489 (File No. E93289)
SA52RCUL, 53RCUL	EA102CUL, 103CUL	BZ6N10CP
SA102CUL, 103CUL SA102RCUL, 103RCUL	–	BZ6N30CP
SA202CUL, 203CUL SA202RCUL, 203RCUL	–	BZ6N40CP
SA402CUL, 403CUL SA402RCUL, 403RCUL	–	BZ6N60CP
SA603RCUL, 803RCUL	–	BZ6N70CP

Note: N type handles for up to 800AF can be padlocked. Padlock is not provided.
N type handles are not CE marked.

● For breakers other than α -TWIN series

N type handles

S series	E series	L, H series	N type handle
SA54B	EA104B	LA53B	BZ-N20C
		H52BA, 53BA H102BA, 103BA	BZ-N30C
SA104R			BZ-N35B
		H202BA, 203BA	BZ-N40C
		H103R, 203R	BZ-N50C
SA204R			BZ-N50B
		H402B, 403B, 403R	BZ-N60C
		H603B, 603R H803B, 803R	BZ-N70C
SA404HA			N-23A
SA604H, 804H			N-41A

G type handles

Type	Standard	Cylinder key type
SA104R	BZ-G35C	BZ-G35C-K
SA204R	BZ-G50C	BZ-G50C-K
SA404HA	G-22A	G-22A-K
SA604H, 804H	G-42A	G-42A-K

V type handles

S series	E series	V type handle
SA32C, 33C SA52C, 53C SA52RC, 53RC SA62C, 63C SA62RC, 63RC SA52RCUL, 53RCUL	EA32AC, 33AC EA52AC, 53AC EA52C, 53C EA62C, 63C EA103AC, 102C, 103C EA102CUL, 103CUL	BZ6V10C UL489 (File No. E93289)
SA102C, 103C SA102CUL, 103CUL SA102RC, 103RC SA102RCUL, 103RCUL		BZ6V30C UL489 (File No. E93289)
SA202C, 203C SA202CUL, 203CUL SA202RC, 203RC SA202RCUL, 203RCUL	EA202C, 203C	BZ6V40C UL489 (File No. E93289)
SA402C, 403C SA402CUL, 403CUL SA402RC, 403RC SA402RCUL, 403RCUL	EA402C, 403C	BZ6V60C UL489 (File No. E93289)
SA603RC, 803RC SA603RCUL, 803RCUL	EA603C, 803C	BZ6V70C UL489 (File No. E93289)

V type handles

S series	E series	L, H series	V type handle
SA54B	EA104B	LA53B	BZ-V20C
		H52BA, 53BA H102BA, 103BA	BZ-V30C
		H202BA, 203BA	BZ-V40C
		H103R, 203R	BZ-V50C
		H402B, 403B, H403R	BZ-V60C
		H603B, 603R H803B, 803R	BZ-V70C

N type operating handles

■ Operating instructions

1. MCCB operation

- Close the door with the handle in the OFF position. Turn the handle to the ON position and the MCCB will be ON.
- Turn the handle to the OFF position and MCCB will be OFF.
- When the breaker trips, the handle moves to the TRIP position. To reset, move the handle to the RESET position.

2. Door locking

- The door cannot be opened when the handle is in the ON, OFF or TRIP position, and can be opened only when the handle is in the OPEN position.
- The breaker cannot be ON when the door is open.
- If it is necessary to open the door with the breaker closed, turn the door lock release screw counterclockwise using a screwdriver.

3. Handle locking

The handle can be locked in either the ON or OFF position when a padlock (not supplied) is used. Pull out the handle lock plate and fit your padlock to the lock plate. If the breaker trips while it is locked in the ON position, the handle moves to the TRIP position.

■ Installation

● BZ6N10C, BZ-N20C, BZ-N30C, BZ-N40C

1. Drilling and cutting the door

Drill and cut the door. The dimensions for drilling and cutting are the same whether the MCCB is installed horizontally or vertically.

2. Preparing a base plate (Fig. 1)

Prepare a base plate to adjust breaker mounting position (base plate: not supplied). Front mounting, front connection type breakers can only be suitable for this handle. Drill the breaker mounting holes on the base plate.

3. Fitting the N-handle mechanism and MCCB to the base plate (Fig. 1)

Commonly tighten the N-handle body and MCCB to the base plate with the mounting screws. For N10C to N30C, tighten two mounting screws on a diagonal line, and for N40C, tighten four mounting screws. Assemble the driving unit so that the breaker handle engages the N handle arm. (Fig. 4)

4. Mounting the decorative plate

Mount the decorative plate and the retaining plate to the door with screws provided. (Fig. 2)

Adjust the position of the handle unit so that it does not tilt against the breaker. (Fig. 3)

Fig. 1

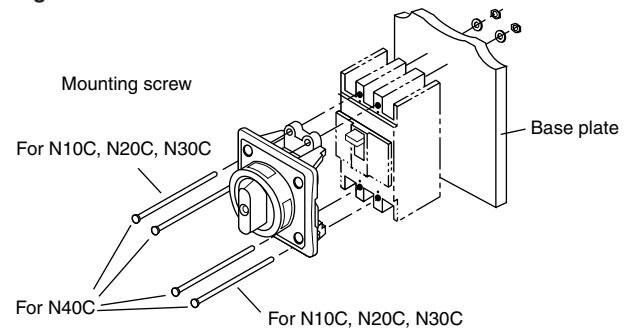

Fig. 2

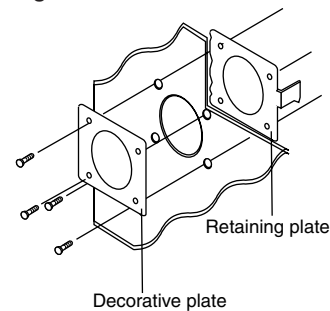

Fig. 3

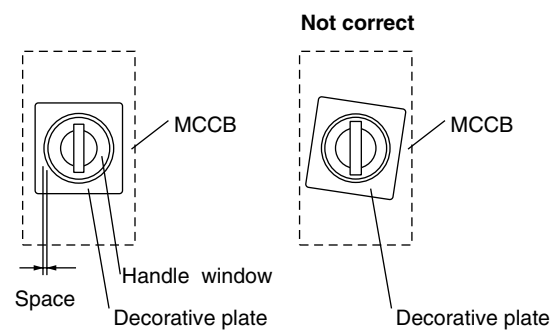
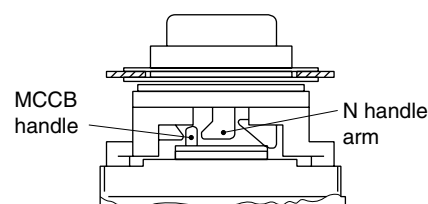

Fig. 4



Molded Case Circuit Breakers

External accessories

N type operating handles

■ Installation

● BZ-N60C, BZ-N70C

1. Drilling and cutting the door

Drill and cut the door. The dimensions for drilling and cutting are the same whether the MCCB is installed horizontally or vertically.

2. Preparing a base plate (Fig. 1)

Prepare a base plate to adjust breaker mounting position (base plate: not supplied). Front mounting, front connection type breakers can only be suitable for this handle. Drill the breaker mounting holes on the base plate.

3. Fitting the N-handle mechanism and MCCB to the base plate (Fig. 1)

Commonly tighten the N-handle body and MCCB to the base plate with the four mounting screws. Assemble the driving unit so that the breaker handle engages the N handle arm. (Fig. 4)

4. Mounting the decorative plate

Mount the decorative plate and the retaining plate to the door with screws provided. (Fig. 2)

Adjust the position of the handle unit so that it does not tilt against the breaker. (Fig. 3)

Fig. 1

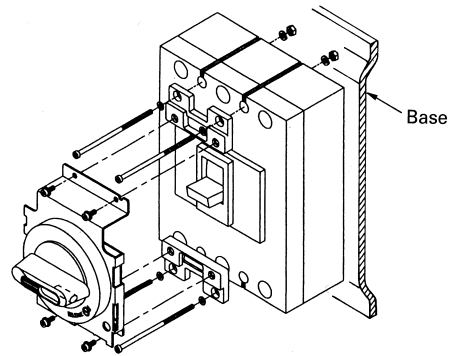

Fig. 2

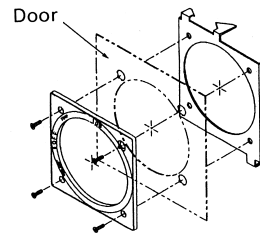

Fig. 3

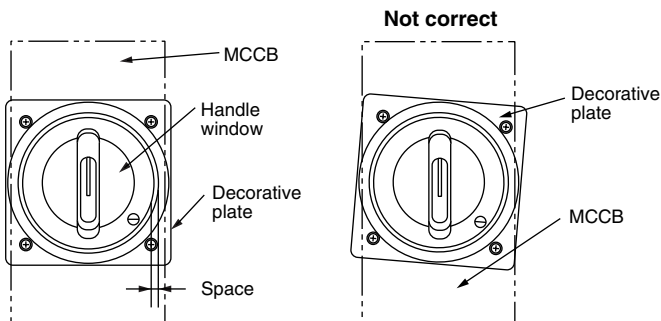
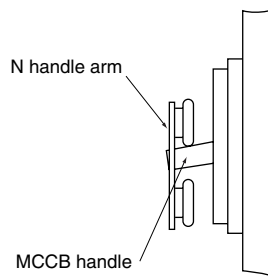

Fig. 4



■ Type number nomenclature

BZ - N □ C T - R

Installation

Blank: Vertically
R: Horizontally, right line side
L: Horizontally, left line side

Door locking device

Blank: Provided
T: Not provided

Basic type

BZ6N10C
BZ-N □ C
N- □ A

Note:

To order an N handle for front-mounting rear connection breakers, add "-X" to the type number, for plug-in mounting breakers, add "-P" to the type number.

Molded Case Circuit Breakers

External accessories

N type operating handles

■ Dimensions, mm

BZ6N10C to BZ-N50C (Dust proof packing: BZ-NP-1C, optional)

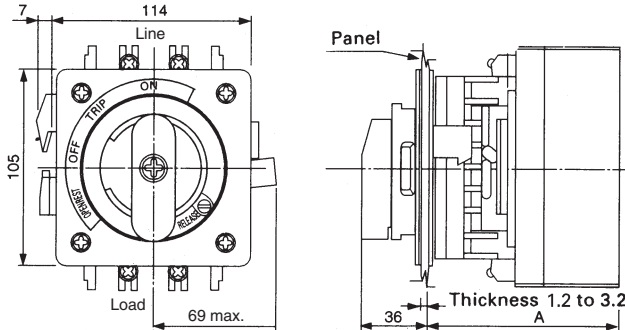

Breaker type	Handle type	A	Mounting Screw	Mass (kg)
SA30C, SA50C, 50RC, SA60C, 60RC SA50RCUL EA30AC, EA50AC, 50C, EA60C EA100AC, 100C, 100CUL	BZ6N10C	103	M4 × 80	0.47
LA53B	BZ-N20C	125	M4 × 110	0.56
SA100C, 100RC, 100CUL, 100RCUL H50BA, 100BA	BZ-N30C	103	M4 × 85	0.56

Door panel cutting

Door hinge installation area

Install the door hinge in the shaded area.

Breaker type	Handle type	A	Mounting Screw	Mass (kg)
EA225C SA225C, 225RC, 225CUL, 225RCUL H225BA	BZ-N40C	103	M4 × 85	0.56
H100R, H225R	BZ-N50C	142	M4 × 125	0.62

BZ-N60C, BZ-N70C (Dust proof packing: BZ-NP-2, optional)

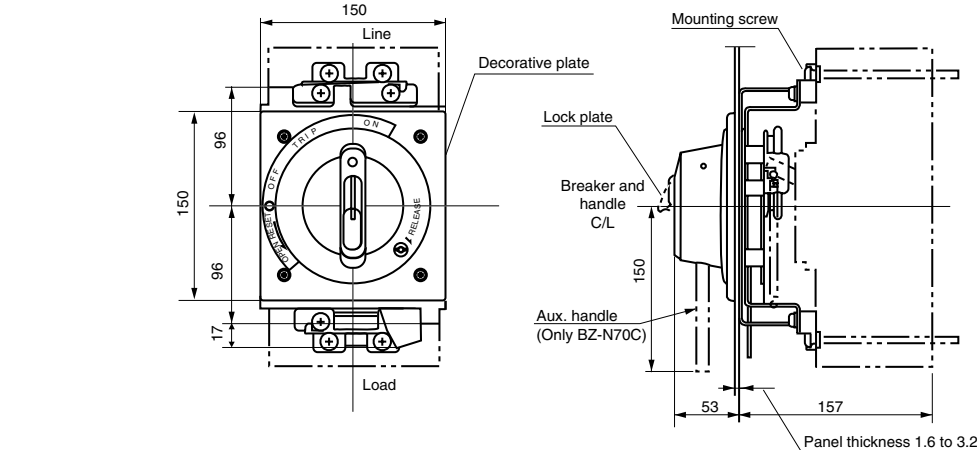

Door panel cutting

Door hinge installation area

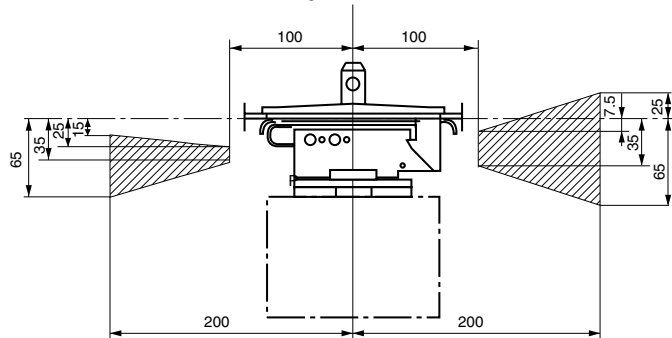

Install the door hinge in the shaded area.

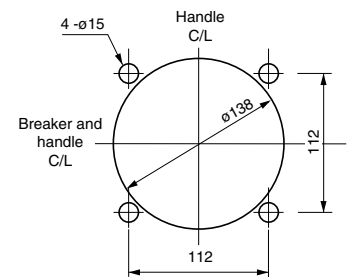

Note: • Handle protection degree IP50 (IEC60529, JIS C 0920) (with the optional dust-proof packing)
• The handle cannot hold the door.

Notes:

- The N type handles are used with front mounting front connection type breakers. They are normally installed vertically. However, it is possible to install them horizontally if required. In this case please specify so in your order. (Example) Specify as follows:
BZ-N□C-R..... Installed horizontally, the line positioned on the right side.
BZ-N□C-L..... Installed horizontally, the line positioned on the left side.

- Breakers use different size screws for the P-type (Plug-in) breakers

Breaker type	Handle type	Mounting screw	Mass (kg)
SA400C, SA400RC SA400CUL, SA400RCUL EA400C H400B, H400R	BZ-N60C	M6 x 110	1.9
SA600RC, SA800RC SA600RCUL SA800RCUL EA600C, EA800C H600B, H800B H600R, H800R	BZ-N70C	M6 x 110	1.9

Molded Case Circuit Breakers

External accessories

N type operating handles

■ Dimensions, mm

N-23A, N-41A (Dust proof packing: BZ-NPB, optional)

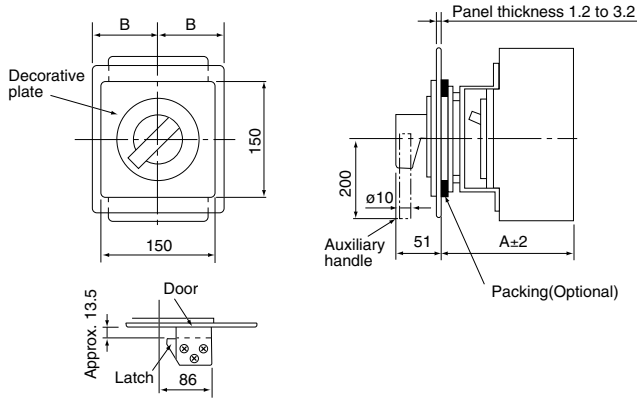

Breaker type	Handle type	Outline dimensions		Mounting screw	Mass (kg)
		A	B		
SA404HA	N-23A	157	73.5	M5 x 60	1.8
SA604H, 804H	N-41A	168	109	M5 x 55	2.3

Notes:

- "B" indicates the maximum dimensions of the N type handle fitting plate or the molded case of breaker.
- The N type handles are used with front mounting front connection type breakers. They are normally installed vertically. However, it is possible to install them horizontally if required. In this case please specify so in your order.
(Example) Specify as follows:
N-□A-R Installed horizontally, the line positioned on the right side.
N-□A-L Installed horizontally, the line positioned on the left side.
- Breakers use different size screws for the X-type (rear connection) or P-type (Plug-in) breakers

Door panel cutting

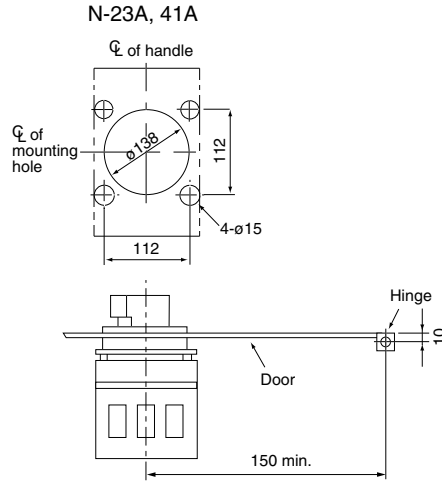

BZ-N35B (Dust proof packing: BZ-NP-1, optional)

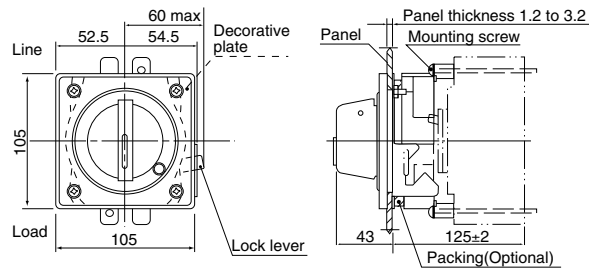

Mass: 0.45kg

Dimensions for reference only. Confirm before construction begins.

Door panel cutting

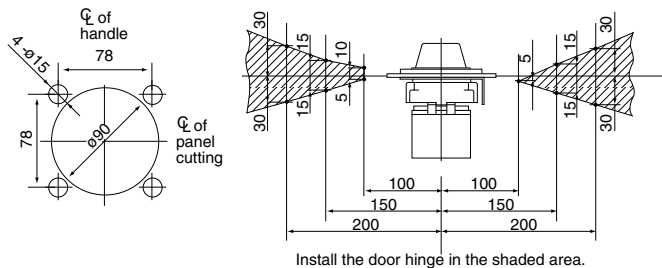

V type operating handles, up to 225AF

■ Operating instructions

1. MCCB operation

- Close the door and turn the handle to the ON position and the breaker will be positioned at ON.
- When the breaker is interrupted automatically the handle will move to the TRIP position.
- To reset move the handle to the RESET position.

2. Door panel locking

- Turn the handle to the RESET position and the lock mechanism will be released thus allowing the door to be opened.
- The door cannot be opened when the breaker is positioned at ON.

3. Handle locking

The padlock can lock the handle in the OFF position.

- Locking MCCB with the door open : Fig.1
 - Locking MCCB with the door closed : Fig.2
- Pull out the lock plate and hook the padlock.

4. Interlock release

This type is provided with an interlock release screw. Turn this screw if it is necessary to open the door in the ON position. This release the lock and allows the door to be opened. When reclosing the door, make sure the handle of the breaker coincides with the position (ON or OFF) of the external handle position.

■ Installation

BZ6V10C to 50-VC

1. Drilling and cutting of the door panel

Drill and cut the door panel as shown in the drawing.

2. Mounting of the MCCB

The distance between the backside of the door panel and breaker mounting plate should be the dimension "H" shown in the drawing below.

H dimensions, mm (Fig.3)

- BZ6V10C, BZ-V20C: 105
(127 for LA50B)
- BZ6V30C, BZ-V30C: 105
- BZ6V40C, BZ-V40C: 105
- BZ-V50C: 144

3. Mounting the driving unit

- Set the breaker handle to the OFF position. Assemble the driving unit so that the breaker handle engages the V handle arm. (Fig.4)
- Secure the driving unit and breaker together to the mounting plate by tightening the four attached mounting screws. (Fig.5)

4. Mounting the handle unit

- Put the handle unit, cover holder, packing, and retainer in front of and behind the panel and tighten the screws temporarily as shown in Fig.6. Adjust the position of the handle unit so that it does not tilt against the breaker. (Fig.7)
- Put the handle of the handle unit in the OFF position and close the door. Check that the shaft engages the latch when the door closes. (Fig.8)

Fig. 1

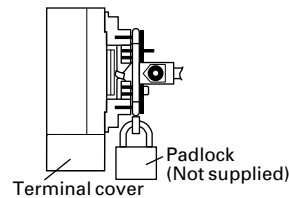

Fig. 2

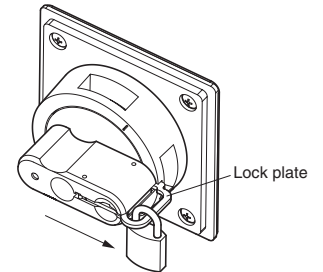

Fig. 3

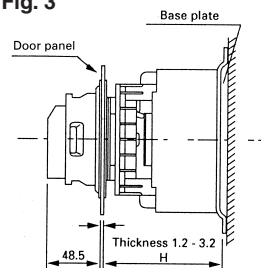

Fig.4

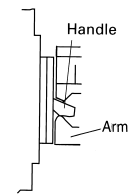

Fig. 5

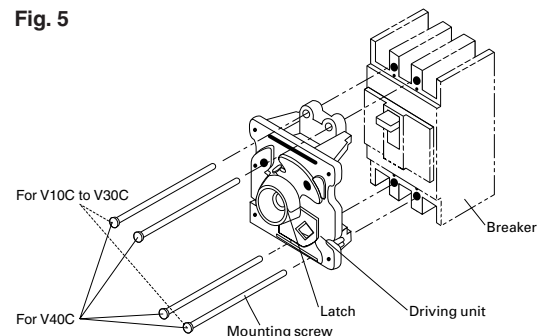

Fig. 6

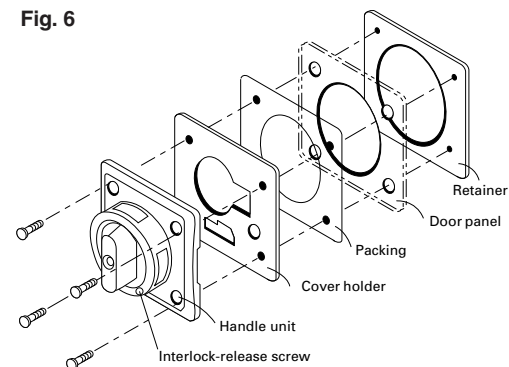

Fig. 7

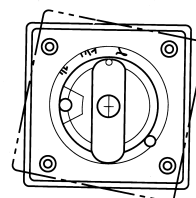
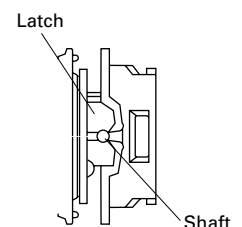

Fig. 8



Molded Case Circuit Breakers

External accessories

V type operating handles

■ Dimensions, mm

BZ6V10C, 6V30C, 6V40C

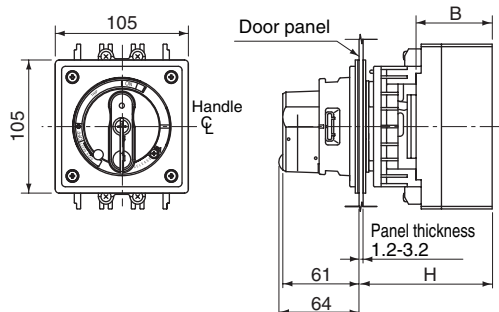

Door panel cutting

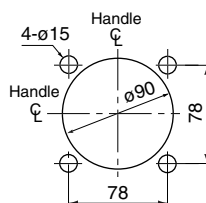

BZ-V20C, V30C, V40V, V50C

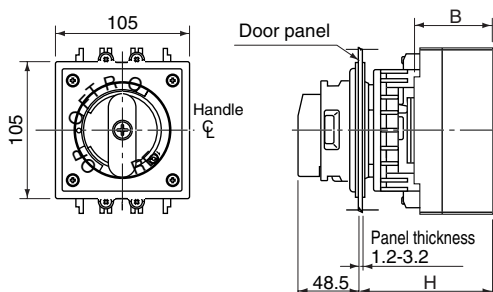

Optional shaft BZ-VS1
X = H - 96

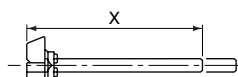

The distance between the handle and breaker can be shortened by cutting the optional shaft.

Door hinge installation area

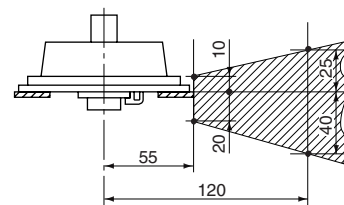

Install the door hinge in the shaded area.

Breaker type			Handle type	Standard type H	With the optional shaft (X=154)			Mounting screw	Mass (kg)
S series	E series	L, H series			H	Area in which the hinge with H can be installed	B		
SA30C SA50C SA50RC SA60C SA60RC SA50RCUL	EA30AC EA50AC EA50C EA60C EA100AC EA100C EA100CUL	—	BZ6V10C	105	250	142 to 250	60	M4 x 80	0.64
SA54B	EA104B	LA53B	BZ-V20C	127	272	164 to 272	82	M4 x 110	0.67
SA100C SA100RC SA100CUL SA100RCUL	—	—	BZ6V30C	105	250	142 to 250	60	M4 x 85	0.67
—	—	H50BA H100BA	BZ-V30C	105	250	142 to 250	60	M4 x 85	0.67
SA225C SA225RC SA225CUL SA225RCUL	EA225C	—	BZ6V40C	105	250	142 to 250	60	M4 x 85	0.67
—	—	H225BA	BZ-V40C	105	250	142 to 250	60	M4 x 85	0.67
—	—	H100R H225R	BZ-V50C	144	289	181 to 289	99	M4 x 125	0.67

Notes:

- Handle protection degree IP54 (IEC60529, JIS C 0920)
- The handle cannot hold the door.

V type operating handles, 400AF to 800AF

■ **Operating instructions**

1. MCCB operation

- Close the door and turn the handle to the ON position and the MCCB will be positioned at ON.
- When the MCCB is interrupted automatically the handle will move to the TRIP position.
- To reset move the handle to the RESET position.

2. Door panel locking

- Turn the handle to the RESET position and the lock mechanism will be released thus allowing the door to be opened.
- The door cannot be opened when the breaker is positioned at ON.

3. Handle locking

The padlock can lock the handle in the OFF position.

- Locking MCCB with the door open: Fig. 1
- Locking MCCB with the door closed: Fig. 2

4. Interlock release

This type is provided with an interlock release screw. Turn this screw if it is necessary to open the door at the ON position. This releases the lock and allows the door to be opened. When reclosing the door, make sure the handle of the breaker coincides with the position (ON or OFF) of the external handle position.

■ **Installation**

BZ6V60C, V70C

1. Drilling and cutting of the door panel

Drill and cut the door panel as shown in the drawing.

2. Mounting of the MCCB

The distance between the backside of the door panel and MCCB mounting plate should be the dimension as shown in Fig.3.

3. Mounting the driving unit

- Set the MCCB handle to the OFF position. Assemble the driving unit so that the MCCB handle engages the V handle arm. (Fig. 4)
- Secure the driving unit and MCCB together to the mounting plate by tightening the four attached mounting screws. (Fig. 5)

4. Mounting the handle unit

- Put the handle unit, packing and retainer in front of and behind the door panel and tighten the screws temporarily as shown in Fig.6. Adjust the position of the handle unit so that it does not tilt against the MCCB. (Fig. 7)
- Put the handle of the handle unit at OFF position and check the latch engages the keeper and close the door while holding the handle unit cover by hand. Final tightening the screws should be performed as keep the engaging position. (Fig. 8)

Fig. 1

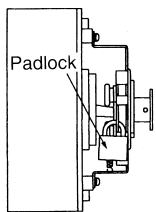

Fig. 2

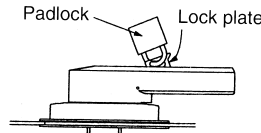

Fig. 3

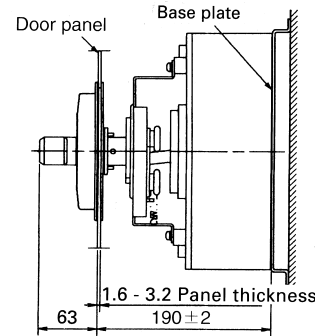

Fig. 4

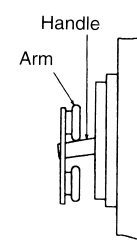

Fig. 5

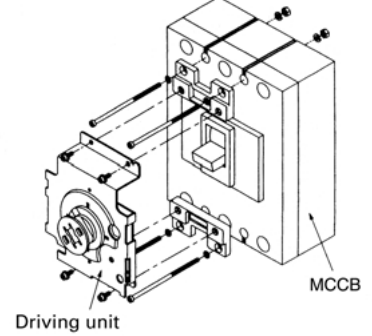

Fig. 6

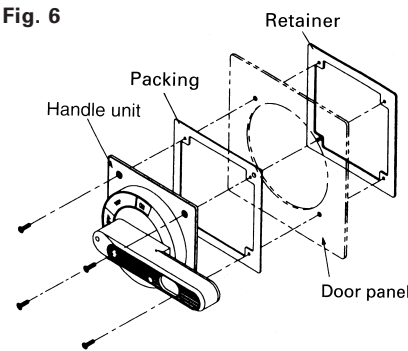
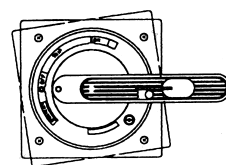

Fig. 7



■ **Type number nomenclature**

BZ6V □ **C** - □

Mounting

- Blank: Front mounting, front connection
- X: Front mounting, rear connection
- P: Plug-in mounting

Basic type

- BZ6V □ C
- BZ-V □ C

Note:

To order a V handle for front-mounting rear connection breakers, add "-X" to the type number; for plug-in mounting breakers, add "-P" to the type number.

Fig. 8

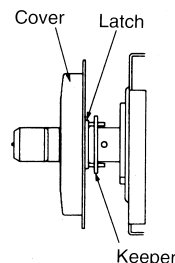

Molded Case Circuit Breakers

External accessories

V type operating handles

■ Dimensions, mm

BZ6V60C, 6V70C, BZ-V60C, V70C

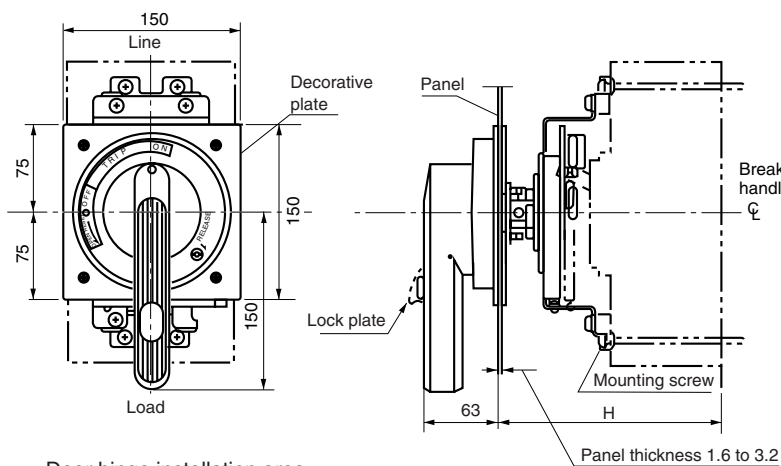

Door panel cutting

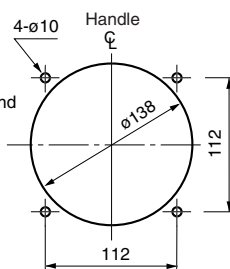

Optional shaft
(BZ-VS2)

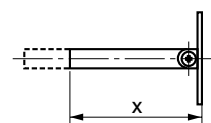

The distance between the handle and breaker can be shortened by cutting the optional shaft.
($X = H - 161.5$)

Door hinge installation area

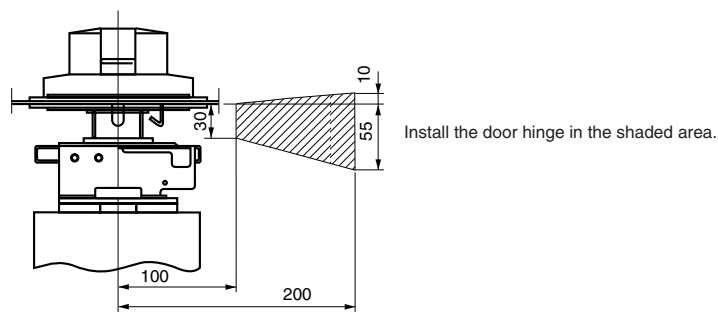

Breaker			Handle type	Standard type H	With the optional shaft		Mass (kg)
S series	E series	H series			H	Area in which the hinge with H can be installed	
SA400C SA400RC SA400CUL SA400RCUL	EA400C	—	BZ6V60C	190±2	250±2	202 to 250	2.2
—	—	H400B H400R	BZ-V60C				2.2
SA600RC SA600RCUL SA800RC SA800RCUL	EA600C EA800C	—	BZ6V70C				2.2
—	—	H600B H600R H800B H800R	BZ-V70C				2.2

Notes:

- Handle protection degree IP54 (IEC60529, JIS C0920).
- The handle cannot hold the door.
- Breakers use different size screws for the X type (rear connection) or P-type (Pulg-in) breakers.

G type operating handles

■ Operating instructions

1. MCCB operation

- Close the door and turn the handle to the ON position and the breaker will be positioned at ON.
- When the breaker is interrupted automatically the handle will move to the TRIP position.
- To reset move the handle to the RESET position.

2. Door panel locking

- Turn the handle to the OPEN position and the lock mechanism will be released thus allowing the door to be opened.
- The door cannot be opened when the breaker is positioned at ON.

3. Handle locking

The cylinder key can lock the handle in either the ON or OFF position. Even if it is locked at the ON position when the breaker trips, the handle will indicate TRIP.



Locked



Unlocked

4. Interlock release

This type is provided with an interlock release screw. Turn this screw if it is necessary to open the door at the ON position. This releases the lock and allows the door to be opened. When reclosing the door make sure the handle of the breaker coincides with the position (ON or OFF) of that of the external handle.

■ Type number nomenclature

BZ-G□C-K

Key

- Blank: Without key
- K: With cylinder key
- Q: With padlocking device

Basic type

- BZ-G□C
- G-□A

■ Installation

BZ-G□C

1. Drilling and cutting of the door panel
Drill and cut the door panel as shown in the drawing.

2. Mounting of the MCCB

The distance between the backside of the breaker mounting plate and breaker should be the dimension "A" as shown in the drawing below.

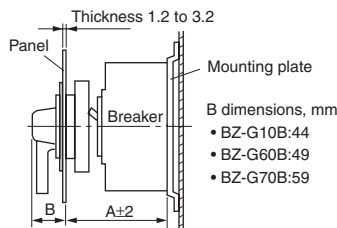

A dimensions, mm

- BZ-G10B : 103
- BZ-G60B, G70B: 157

Mount the breaker and the retaining plate commonly to the panel board.

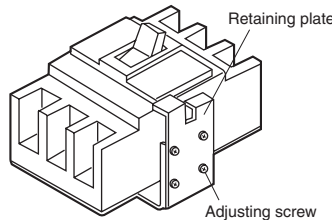

3. Fit the decorative plate and handle mechanism to the door panel by means of the mounting screws as shown in the illustration.

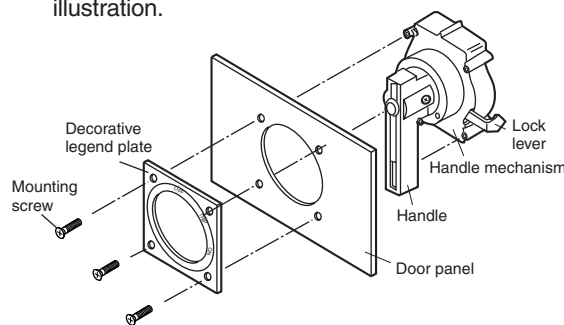

4. Adjust the height of the retaining plate by means of adjusting screws.

G-120A, 160A

1. Drilling and cutting of the door panel
Drill and cut the panel as shown in the drawing.

2. Mounting of the MCCB

When mounting the MCCB to the panel board make sure that the retaining plate and the supporter (type H-11 separately sold) engage correctly.

3. Fitting the G type handle (Refer to the illustration.)

- First remove the set screw③and handle mounting screws②. Then remove handle①, decorative plate④and operating mechanism⑦.
- Fit the decorative plate④and handle mechanism⑦to the panel⑥by means of the mounting screws②as shown in the illustration.
- Insert the handle on the shaft⑤and secure by means of the set screw③

4. Adjust the height of the retaining plate (H-11) by means of the adjusting screws.

5. Check the door for play. Carry out the retaining plate adjustment once more taking up any endplay.

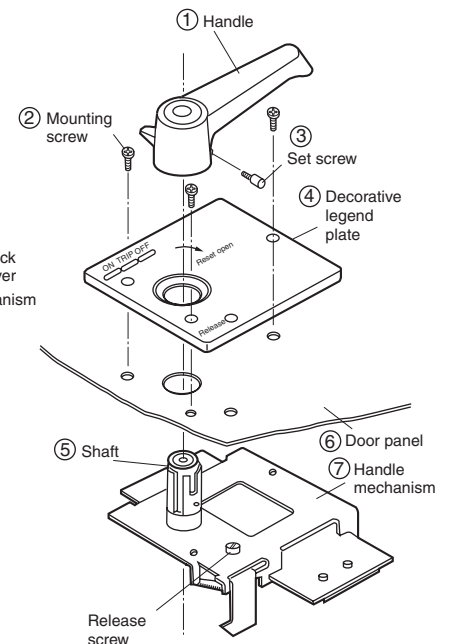

Molded Case Circuit Breakers

External accessories

G type operating handles

■ Dimensions, mm BZ-G35C, BZ-G50C

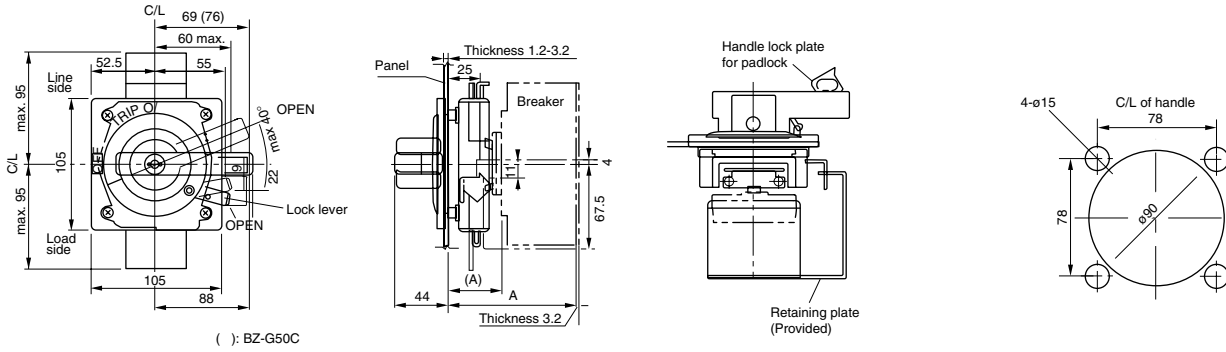

Breaker type	Handle type	A (A)	Mass (kg)
SA104R	BZ-G35C, BZ-G35C-K	125±2 (43)	1.2
SA204R	BZ-G50C, BZ-G50C-K	130±2 (47.5)	

G-22A

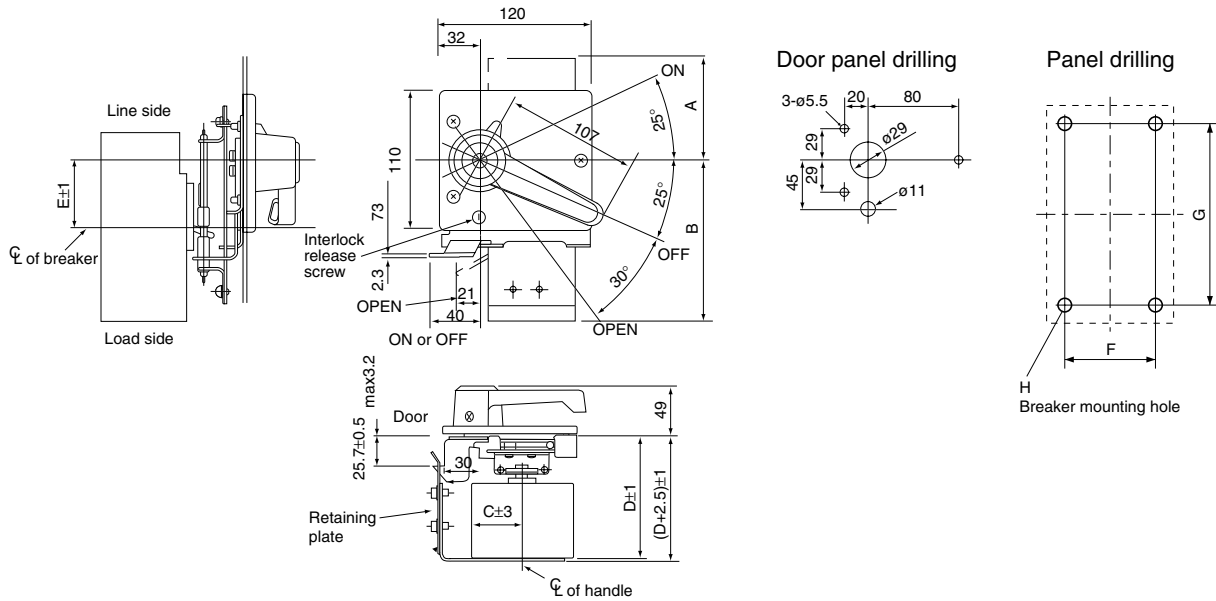

Dimensions for reference only. Confirm before construction begins.

Breaker type	Handle type	A	B	C	D	E	F	G	H	Retaining plate
SA404HA	G-22A, G-22A-K	111	152	40	150	36	44	215	M6 or ø7	H-2
SA604H SA804H	G-42A, G-42A-K	117	133	40	157	36	70	243	M6 or ø7	H-5

■ Dimensions, mm

Retaining plate and supporter (Sold separately)

H-2

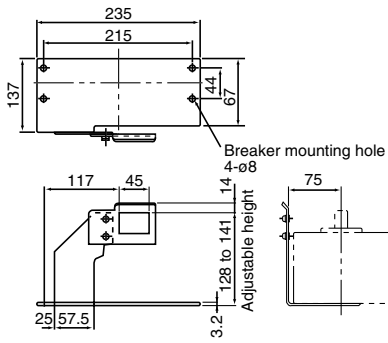

H-5

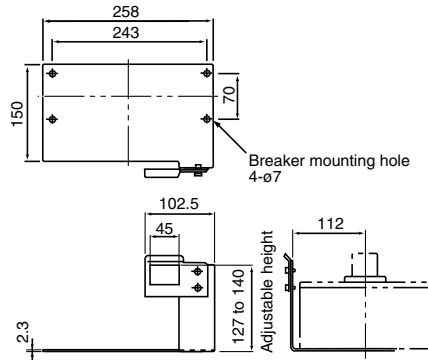

Molded Case Circuit Breakers

External accessories

Steel enclosures

Pressed steel enclosures

■ Description

BZ-type enclosures are available in three types — two with V and G-type handle which allows the operation from the outside and other with the operating handle of the breaker extending from it to allow it to be directly switched ON or OFF from outside the enclosure.

Enclosures with V and G-type handles are provided with a door interlocking mechanism which prevents the door from being opened in the ON condition.

Knockout holes for wiring use are provided as shown in the diagram.

(For G-type handles, contact FUJI.)



■ Type of enclosures

Breaker type			Enclosure		
S series	E series	H series	Standard	With V type handle Dustproof *1	Rainproof *2 *3
SA32C, SA52C, SA52RC SA62C, SA62RC	EA32AC, EA52AC EA52C, EA62C	—	BZ6C10C2	BZ6CV10C	BZ6CW10C
SA33C, SA53C, SA53RC SA63C, SA63RC	EA33AC, EA53AC EA53C, EA63C	—	BZ6C10C3	BZ6CV10C	BZ6CW10C
—	EA102C	—	BZ6C25C2	BZ6CV25C	BZ6CW25C
—	EA103C EA103AC	—	BZ6C25C3	BZ6CV25C	BZ6CW25C
SA102C	—	—	BZ6C30C2	BZ-CV30C	BZ-CW30C
SA102RC SA103C, SA103RC	—	—	BZ6C30C3	BZ-CV30C	BZ-CW30C
—	—	H52BA, H53BA H102BA, H103BA	BZ-C30B-3	BZ-CV30C	BZ-CW30C
SA202C, SA202RC SA203C, SA203RC	EA202C EA203C	H202BA, H203BA	BZ-C40B	BZ-CV40C	BZ-CW40C
—	—	H103R H203R	BZ-C50B	—	—
SA402C, SA402RC SA403C, SA403RC	EA402C EA403C	H402B, H403B H403R	BZ-C60B	BZ-CV60C	BZ-CW60C
SA603RC SA803RC	EA603C EA803C	H603B, H603R H803B, H803R	BZ-C70B	BZ-CV70C	—

Notes: • Protection degree (IEC60529) *1: IP40 *2: IP54
 • *3 BZ-CV40C and rainproof steel enclosures not available for the H series.

■ Ordering information

Specify the following:

1. Type number of enclosures

■ Dimensions, mm

Standard

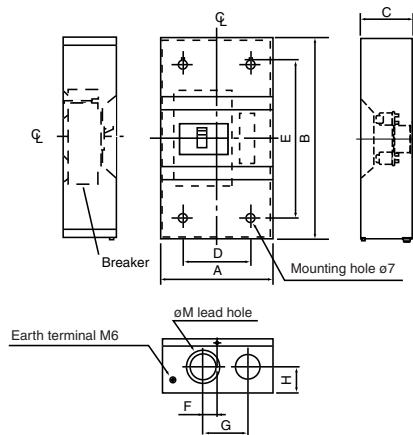

With V type handle

BZ6CV10C to BZ-CV40C

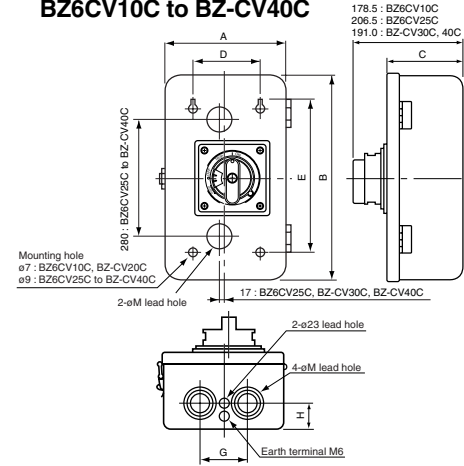

BZ-CV60C, 70C

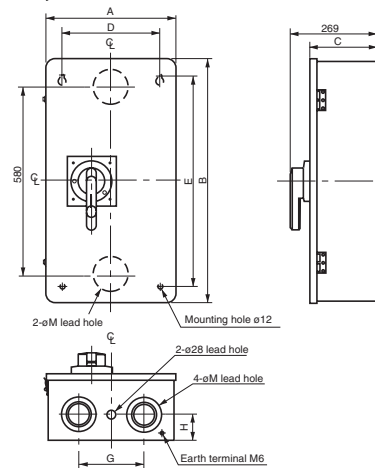

■ Connection method diagrams

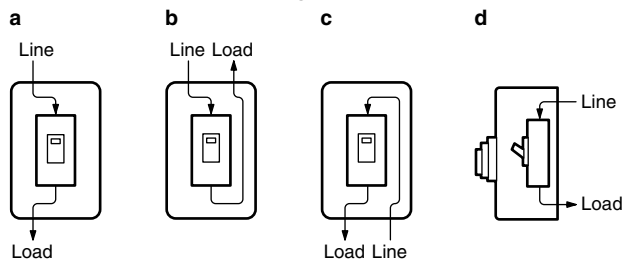

Type	Connection	A	B	C	D	E	F	G	H	M (Ø)	Mass (kg)
BZ6C10C2	a, b, c	135	225	95	90	170	25	65	40	22, 35	1.35
BZ6C10C3											
BZ6C25C2											
BZ6C25C3											
BZ6C30C2, BZ-C30B-2											
BZ6C30C3, BZ-C30B-3											
BZ-C40B											
BZ-C50B											
BZ-C60B											
BZ-C70B											
BZ-C120	a, b, c, d	520	1150	200	400	950	100	200	80	63, 78, 106	19.3
BZ6CV10C											
BZ-CV25C											
BZ-CV30C											
BZ-CV40C											
BZ-CV60C	400	750	206	300	650	-	200	80	63, 78, 106	21.7	
BZ-CV70C											

Molded Case Circuit Breakers

External accessories

Terminal covers

Terminal covers

■ Description

These terminal covers are used as guards to prevent accidental touch with live line terminations.

These terminal covers can be fitted to either line or load side.

● Up to 225AF

Short type BZ-TS

- Snap-on fitting
- Transparent and black(BZ6TS10 only), sealing possible

Long type BZ-TB

- Crimp connection use
- Transparent and black(BZ6TB10 only), sealing possible

● 400AF and larger

Long type BZ-TB

- Transparent

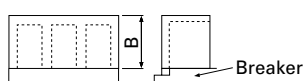
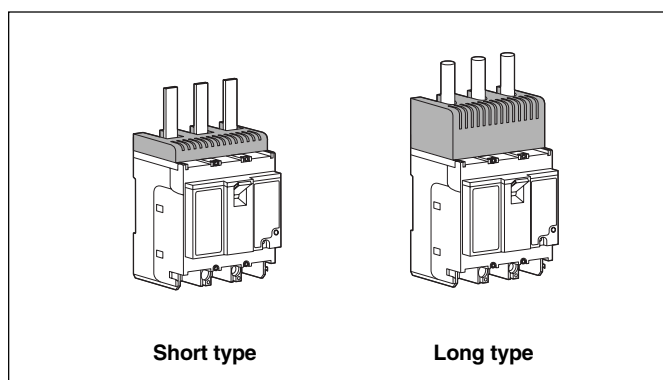

● IEC and CE marking conformed

Packing quantity : 2 pcs.

Breaker type	Terminal cover	B dimension	Mass	Terminal cover	B dimension	Mass
S series	Short type	(mm)	(g)	Long type	(mm)	(g)
SA32C	BZ6TS10C2 (Black)	10	25	BZ6TB10C2 (Black)	40	68
SA52C, SA52RC	BZ6TSH10C2 (Transparent)	10	25	BZ6TBH10C2 (Transparent)	40	68
SA62C, SA62RC						
SA33C	BZ6TS10C3 (Black)	10	32	BZ6TB10C3 (Black)	40	87
SA53C, SA53RC						
SA63C, SA63RC	BZ6TSH10C3 (Transparent)	10	32	BZ6TBH10C3 (Transparent)	40	87
SA54B	BZ-TS20B-4	10	41.3	BZ-TB20B-4	30	90
SA102C	BZ-TS30B-2	10	29	BZ-TB30B-2	40	64
SA102RC	BZ-TS30B-3	10	43	BZ-TB30B-3	40	86
SA103C, SA103RC						
SA104R	–	–	–	BZ-TB35B-4	40	163
SA202C, SA202RC	BZ-TS40B	10	60	BZ-TB40B	50	107
SA203C, SA203RC						
SA204R	–	–	–	BZ-TB45B-4	50	204
–	BZ-TS50B	10	76	BZ-TB50B	40	175
SA402C, SA402RC	–	–	–	BZ-TB60B	116	549
SA403C, SA403RC						
SA603RC	–	–	–	BZ-TB70B	135	568
SA803RC						
SA603RC	EA603C	H603B, H603R	–	–	–	–
SA803RC	EA803C	H803B, H803R	–	–	–	–

● UL Listed

Breaker type	Terminal cover	Mass	Terminal cover	Mass	Terminal cover	Mass
S series	Short type	(g)	Long type	(g)	For flat terminal	(g)
SA52RCUL	BZ6TS10C2U (Black)*	26.5	BZ6TB10C2U (Black)	69.5	–	–
SA53RCUL	BZ6TS10C3U (Black)*	33.5	BZ6TB10C3U (Black)	88.5	–	–
SA102CUL, SA102RCUL	BZ-TS30B-3	43	BZ-TB30B-3	86	BZ-TL30B-3	45
SA103CUL, SA103RCUL						
SA202CUL, SA202RCUL	BZ-TS40B	60	BZ-TB40B	107	BZ-TL40B	60
SA203CUL, SA203RCUL						
SA402CUL, SA402RCUL	–	–	BZ-TB60B	549	–	–
SA403CUL, SA403RCUL						
SA602RCUL	–	–	BZ-TB70B	568	–	–
SA803RCUL	–	–	–	–	–	–

Note: * Standard-provided

Insulation barriers

■ Description

The interphase barriers are provided on frame size of 30AF to 1200AF breakers for front mounting. The barriers are installed in the molded slots between terminals.

The earth barrier is used to increase the insulation with the mounting plate surface when two crimp terminals are wired. Installation of these barriers after wiring is possible even when an external accessory is installed.

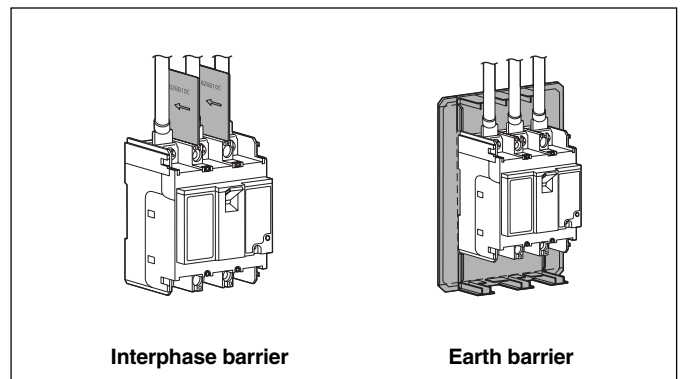

● Interphase barrier

Breaker type			Interphase barrier				
S series	E series	L and H series	Type	Dimensions, mm		Packing quantity	Mass (g)
				A	B		
SA32C SA52C, 52RC SA62C, 62RC	EA32AC EA52AC, 52C EA62C EA102C	—	BZ6B10C	50	49	4	23
SA33C SA53C, 53RC SA63C, 63RC	EA33AC EA53AC, 53C EA63C EA103AC, 103C	—	BZ-B30B	50	51	4	29
SA102C, 102RC, 102CUL, 102RCUL SA103C, 103RC, 103CUL, 103RCUL	—	LA53B(Line*1) H52BA, 53BA H102BA, 103BA		50	58	4	31
SA102CUL, 103CUL SA102RCUL, 103RCUL	—	—	BZ6B30CU	58	58	4	31
SA202C, 202RC SA203C, 203RC	EA202C EA203C	H202BA H203BA	BZ-B40B	80	52	4	48
SA202CUL, 203CUL SA202RCUL, 203RCUL	—	—	BZ6B40CU	80	58.5	4	52
—	—	H103R H203R	BZ-B50B	90	58.5	4	52
—	—	H103R H203R	BZ-B50B	80	90.5	4	82
SA402C, 402RC, 402CUL, 402RCUL SA403C, 403RC, 403CUL, 403RCUL SA603RC, 603RCUL SA803RC, 803RCUL S1003, 1203	EA402C EA403C EA603C EA803C	H402B H403B, 403R H603B, 603R H803B, 803R	B-43A	105	95	4	131
SA404H SA604H, 804H	—	—	B-44A	105	95	6	195

Interphase barrier

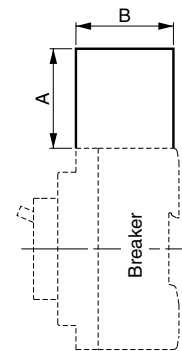

● Earth barrier

Breaker type			Earth barrier				
S series	E series	L and H series	Type	Dimensions, mm*2		Packing quantity	Mass (g)
				A	B		
SA32C SA52C, 52RC SA62C, 62RC	EA32AC EA52AC, C EA62C EA102C	—	BZ6BL10C2	100 (50, 75)	43 (30)	2	33
SA33C SA53C, 53RC SA63C, 63RC	EA33AC EA53AC, C EA63C EA103AC, C	—	BZ6BL10C3	125 (75, 100)	43 (30)	2	41
—	—	LA53B	BZ-BL20B-3	125 (75, 100)	70 (30)	2	20
SA102C	—	—	BZ-BL30B-2	100 (60, 80)	70 (40)	2	11
SA102RC SA103C, 103RC	—	H52BA, 53BA H102BA, 103BA	BZ-BL35B	130 (90, 110)	70 (40)	2	16
SA202C, 202RC SA203C, 203RC	EA202C EA203C	H202BA H203BA	BZ-BL40B	190 (105, 147)	100 (50, 72)	2	48
—	—	H103R H203R	BZ-BL50B	190 (105, 147)	100 (50, 72)	2	48

Earth barrier

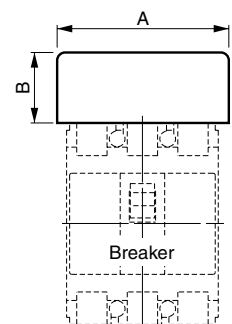

Notes: *1 Barrier type for the load side is BZ-B35B.

Interphase barriers are standard provided for the front mounting type breaker.

4-pole types are available for interphase barrier only, and 2-sets are required.

*2 The value in parentheses is the dimensions after the barrier is cut.

Molded Case Circuit Breakers

Accessories

Mounting modification kits

Mounting modification kits

Standard type breakers are front mounting front connections. The standard breaker can easily be modified to become front mounting rear connection and flush mounting types by using the modification kits.

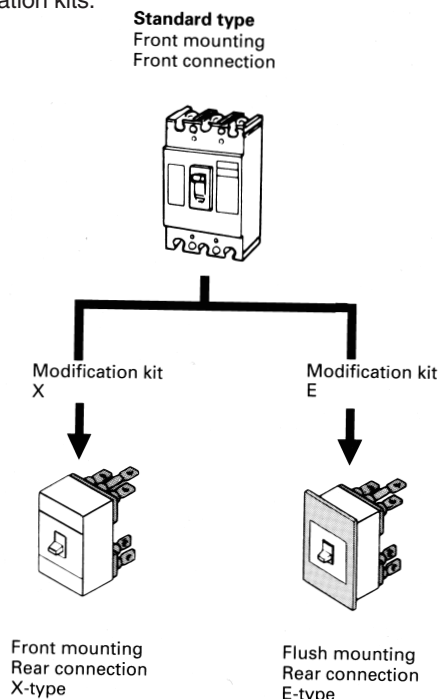

Modification kits

● For front mounting, front connection (Flat terminal)

Breaker type	Kit type	
	For 2-pole	For 3-pole
SA30C, 50C, 50RC EA30AC, 50AC, 50C	BZ6S10C502	BZ6S10C503
SA60C, 60RC EA60C, 100AC, 100C	BZ6S10C1002	BZ6S10C1003
LA53B	–	BZ-S20B-503
SA100C, 100RC	BZ-S35B-1002	BZ-S35B-1003
SA225C, 225RC EA225C	BZ-S50B-2252	BZ-S50B-2253
H50BA, 100BA	BZ-S35B-1002	BZ-S35B-1003
H225BA	BZ-S50B-2252	BZ-S50B-2253
H100R, 225R	–	BZ-S50B-2253

Note: • BZ6S10C502 for EA102C/50, BZ6S10C503 for EA103C/50

UL Listed / Flat terminal

Breaker type	Kit type
SA50RCUL	BZ-SU20B
EA100CUL	BZ-SU25B
SA100CUL SA100RCUL	BZ6SU35B
SA225CUL SA225RCUL	BZ6SU50B
SA400CUL SA400RCUL	BZ-SU60B
SA600RCUL	BZ-SU70B-600
SA800RCUL	BZ-SU70B-800

Black terminal: See page 06/29 "Quick reference guide"

● For front mounting, rear connection (X type)

Breaker type	Kit type	
	For 2-pole	For 3-pole
SA30C, 50C, 50RC EA30AC, 50AC, 50C	BZ6X10C502	BZ6X10C503
SA60C, 60RC EA60C, 100AC, 100C	BZ6X10C1002	BZ6X10C1003
SA100C, 103RC	BZ-X30C-1002	BZ-X30C-1003
SA102RC	BZ-X31C-1002	
SA225C, 225RC EA225C H225BA	BZ-X40B-2252	BZ-X40B-2253
SA400C, 400RC EA400C	BZ-X60B-4002	BZ-X60B-4003
H50BA, 100BA	BZ-X31C-1002	BZ-X30C-1003
H100R, 225R	–	BZ-X50B-2253
H400B, 400R	BZ-X60B-4002	BZ-X60B-4003

Note: • BZ6X10C502 for EA102C/50, BZ6X10C503 for EA103C/50

● For flush mounting, rear connection (E type)

Breaker type	Kit type	
	For 2-pole	For 3-pole
SA30C, 50C, 50RC EA30AC, 50AC, 50C	BZ6E10C502	BZ6E10C503
SA60C, 60RC EA60C, 100AC, 100C	BZ6E10C1002	BZ6E10C1003
SA100C	BZ6E30C1002	BZ6E30C1003
SA102RC	BZ6E31C1002	–
SA103RC	–	BZ6E30C1003
SA225C, 225RC EA225C	BZ6E40B2252	BZ6E40B2253
H50BA, 100BA	BZ-E31C-1002	BZ-E30C-1003
H225BA	BZ-E40B-2252	BZ-E40B-2253
H100R, 225R	–	BZ-E50B-2253
SA400C, 400RC EA400C H400B, 400R	BZ-E60B-4002	BZ-E60B-4003

● For flush mounting, top and bottom connection (Y type)

Breaker type	Kit type	
	For 2-pole	For 3-pole
SA30C, 50C, 50RC EA30AC, 50AC, 50C	BZ6Y10C502	BZ6Y10C503
SA60C, 60RC EA60C, 100AC, 100C	BZ6Y10C1002	BZ6Y10C1003

Molded Case Circuit Breakers Accessories

Mounting modification kits and padlocking device

■ Mass

For front mounting, front connection		For front mounting, rear connection (X type)		For flush mounting, rear connection (E type)	
Kit type	Mass (kg)	Kit type	Mass (kg)	Kit type (g)	Mass (kg)
BZ6S10C502	0.1	BZ6X10C502	0.3	BZ6E10C502	0.44
BZ6S10C503	0.15	BZ6X10C503	0.43	BZ6E10C503	0.59
BZ6S10C1002	0.25	BZ6X10C1002	0.30	BZ6E10C1002	0.44
BZ6S10C1003	0.35	BZ6X10C1003	0.43	BZ6E10C1003	0.59
BZ-S20B-503	0.1	BZ-X30C-1002	0.46	BZ6E30C1002	0.91
BZ-S35B-1002	0.25	BZ-X30C-1003	0.63	BZ6E30C1003	1.33
BZ-S35B-1003	0.35	BZ-X31C-1002	0.39	BZ6E31C1002	1.06
BZ-S50B-2252	0.35	BZ-X40B-2252	0.52	BZ6E40B2252	1.17
BZ-S50B-2253	0.5	BZ-X40B-2253	0.77	BZ6E40B2253	1.42
		BZ-X50B-2253	0.80	BZ-E31C-1002	0.86
		BZ-X60B-4002	1.98	BZ-E30C-1003	1.11
		BZ-X60B-4003	2.71	BZ-E40B-2252	0.97
				BZ-E40B-2253	1.22
				BZ-E50B-2253	1.27
				BZ-E60B-4002	3.40
				BZ-E60B-4003	3.67

06

■ Padlocking device (UL not approved)

Breaker handles can be fitted with locks. The handle can be locked at either the ON or OFF position. If an overcurrent flows, the breaker trips even when the handle is kept locking. Add the suffix Q1 or Q2 to the ELCB type number to order the padlocking device (not sold separately).

Q1 : Cap type, Q2 :Plate type

Applicable padlocking device

S series	E series	L•H series
SA30C	EA30AC	LA50B
SA50C	EA50C	
SA50RC	EA50AC	H50BA
SA60C	EA60C	
SA60RC	EA100C	H100BA
SA100C		
SA100RC	EA225C	
		H225BA
SA225C		
SA225RC	EA400C	
		H400B
SA400C	EA600C	H400R
SA400RC		
	EA800C	H600B
SA600RC		H600R
SA800RC		H800B
		H800R

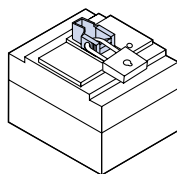

Cap type Q1*(400 to 800AF)

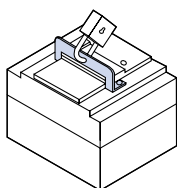

Plate type Q2

A padlock is not provided.

■ Handle locking covers/30 to 225AF

Breaker type	Handle locking cover	Handle locking cover
EA30AC, 50AC, 50C		BZ6L10C
SA30C, 50C, 50RC, 50RCUL, 60C, 60RC		
EA60C, 100C, 100AC, 100CUL		
SA100C, 100RC, 100CUL, 100RCUL		BZ6L30C
SA225C, 225RC, 225CUL, 225RCUL		
EA225C		BZ6L40C
H225BA		

Molded Case Circuit Breakers

Distribution breakers

F series

Distribution breakers: F series

■ Features

This breaker is used for protection of lighting and heating branch circuits.

- Compact and light in weight
- Large breaking capacity

Breaker ampere frame	Ampere rating	1-pole 240 volts AC Type	2-pole 240 volts AC Type	3-pole 240 volts AC Type	
50	15	F51B/15	F52B/15	F53B/15	
	20	F51B/20	F52B/20	F53B/20	
	30	F51B/30	F52B/30	F53B/30	
	40	F51B/40	F52B/40	F53B/40	
	50	F51B/50	F52B/50	F53B/50	
100	60	—	F102B/60	F103B/60	
	75	—	F102B/75	F103B/75	
	100	—	F102B/100	F103B/100	

■ Ordering information

Specify the following:

1. Type number

■ Type number nomenclature

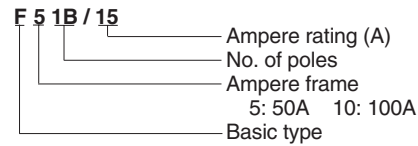

■ breaking capacities

Type		Distribution breaker				
		F51B	F52B	F53B	F102B	F103B
Short-circuit breaking capacity (kA)	JIS	2.5	2.5	—	2.5	—
	C8370	—	—	2.5	—	2.5
	265V AC	—	5	5	5.5	5.5
	220V AC	5	—	—	—	—
BS	240/415V AC	3	3	—	—	—
	240V AC	3	3	3	3	3
Mass (kg)		0.18	0.35	0.55	0.41	0.65

■ Characteristic curves

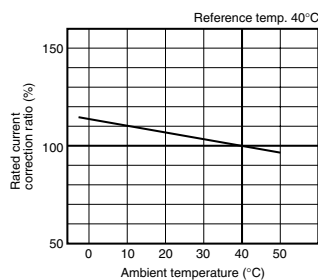
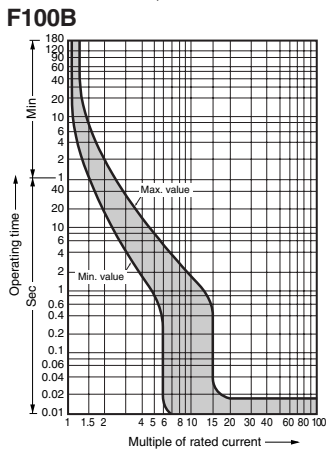
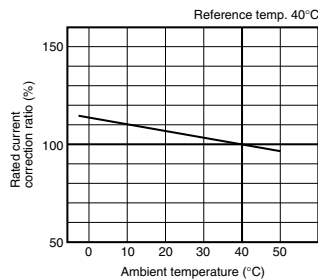
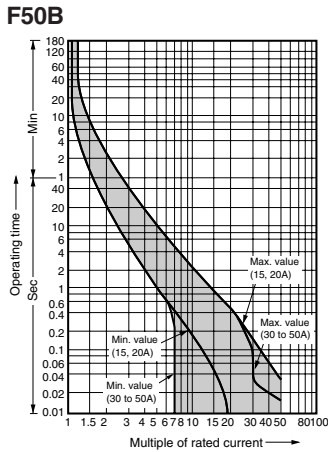

■ Dimensions, mm

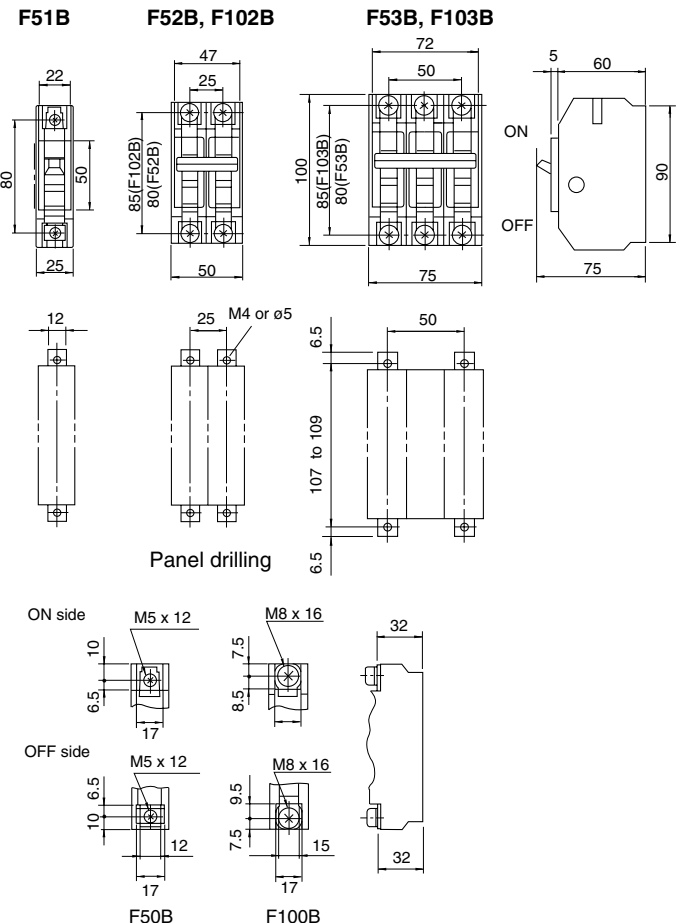

Solid-state trip types, SA1000E, 1200E, 1600E

■ Features

- **Equipped with a load current pre-trip alarm**
Constantly monitors the load current, and outputs an alarm when the set current is exceeded.
- **Adjustable rated current**
The rated current is easy to vary in 5 to 6 steps using an adjustment dial.
- **Wide-range-adjustable trip characteristics**
The current and time for instantaneous tripping and short-/long-time delay tripping can be set by the user.
- **Adjustable ground fault tripping determinate and set a current level for ground fault detection in the ranging between 10% to 40% of the rated CT current.**



■ Type number nomenclature

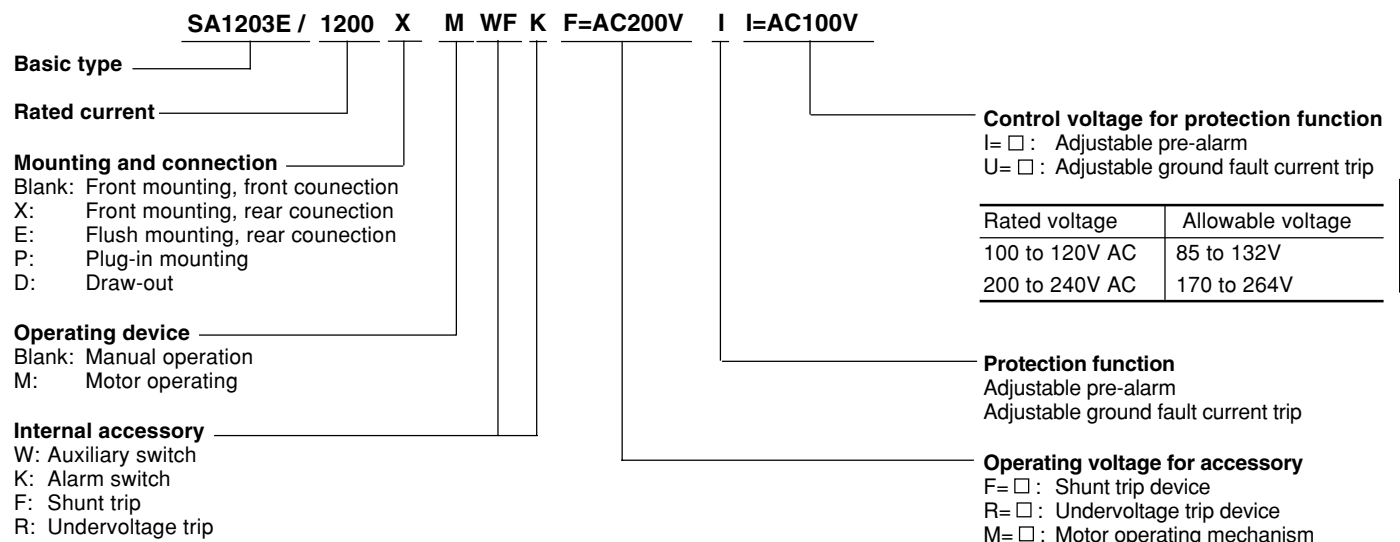

■ Ordering information

Specify the following:

1. Type number

Molded Case Circuit Breakers

Solid-state trip types

■ S series

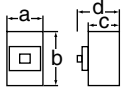
Frame		1000A		1200A		1600A		
Pole		3	4	3	4	3	4	
Type		SA1003E	SA1004E	SA1203E	SA1204E	SA1603E	SA1604E	
Rated current(A)		Adjustable 500—600—700—800 —900—1000		Adjustable 600—700—800—1000 —1200		Adjustable 800—900—1000—1200 —1400—1600		
Rated insulation voltage(V)		AC DC	690 —	690 —	690 —	690 —	690 —	
Rated breaking capacity (kA)	JIS C8370 (sym)	550V AC 460V AC 220V AC 250V DC	50 65 100 —	50 65 100 —	50 65 100 —	65 85 130 —	65 85 130 —	
	IEC 60947-2 (Icu/Ics) BS 4752 (sym)*	690V AC 660V AC 600V AC 500V AC 440V AC 400V AC 230V AC 250V DC	25/19 25/19 25/19 45/34 65/49 65/49 100/75 —	25/19 25/19 25/19 45/34 65/49 65/49 100/75 —	25/19 25/19 25/19 45/34 65/49 65/49 100/75 —	45/34 45/34 45/34 65/49 85/64 85/64 125/94 —	45/34 45/34 45/34 65/49 85/64 85/64 125/94 —	
Dimensions (mm)		a	210	280	210	280	210	280
		b	370		370		370	
		c	120		120		140	
		d	171		171		191	
Protection function	Long-time delay tripping time (s)	5-30 (at 6In) (Adjustable)						
	Short-time delay tripping current (A)	2In-10In (Adjustable)						
	Short-time delay tripping time (s)	0.1-0.3 (Adjustable)						
	Instantaneous tripping current (kA)	3.0-12 (Adjustable)		3.75-15 (Adjustable)		4.8-19.2 (Adjustable)		
	Ground fault current tripping or pre-alarm	●		●		●		
Mass(kg) Front mounting, front connection		22	28	22	28	27	35	
Tripping device		Solid-state		Solid-state		Solid-state		
Trip button		Provided		Provided		Provided		
Mounting	Front mounting, front connection	No mark	●		● Bar stud	●		
	Front mounting, rear connection	X	● Bar Stud		● Bar stud	● Bar stud		
	Flush mounting, rear connection	E	● Bar Stud		●	● Bar stud		
	Plug-in mounting	P	—		—	—		
Internal accessories	Auxiliary switch	W	●		●	●		
	Alarm switch	K	●		●	●		
	Shunt trip	F	●		●	●		
	Undervoltage trip	R	●		●	●		
External accessories	Motor operating mechanism	M	●		●	●		
	Lead-wire terminal block	—	●		●	●		

Note: * For SA1200E and SA1600E

● Available — Not available

Protection function

• Long-time delay tripping (Rated current adjustable)

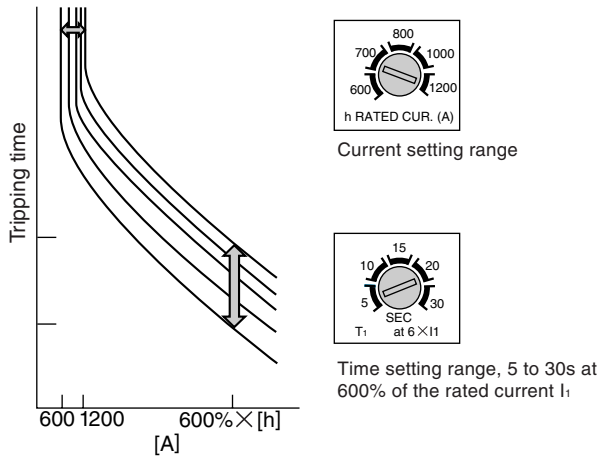

• Adjustable instantaneous tripping

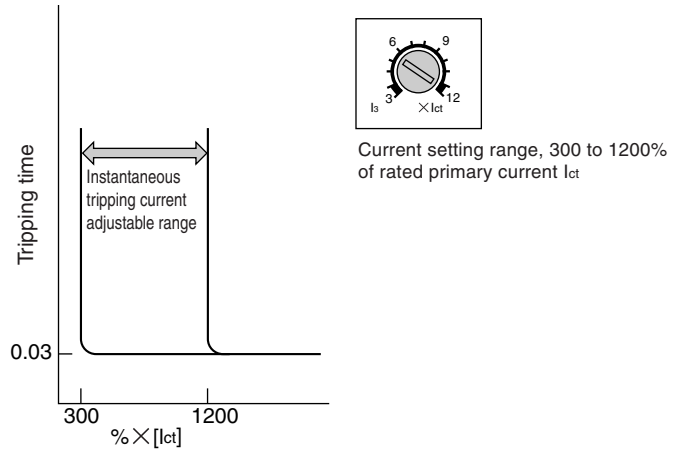

• Adjustable short-time delay tripping

Coordination with solid-state trip type MCCB

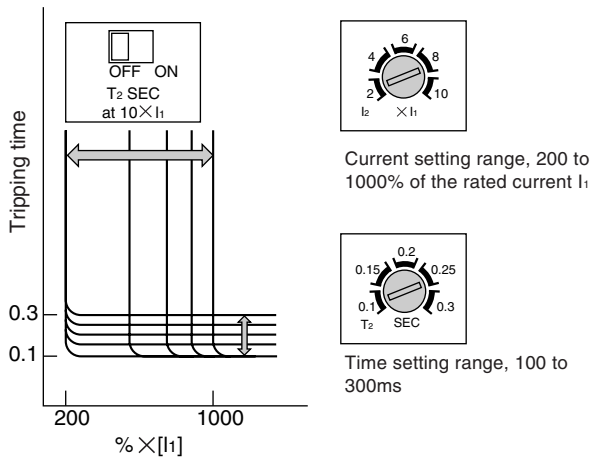

Coordination with thermal-magnetic trip type MCCB

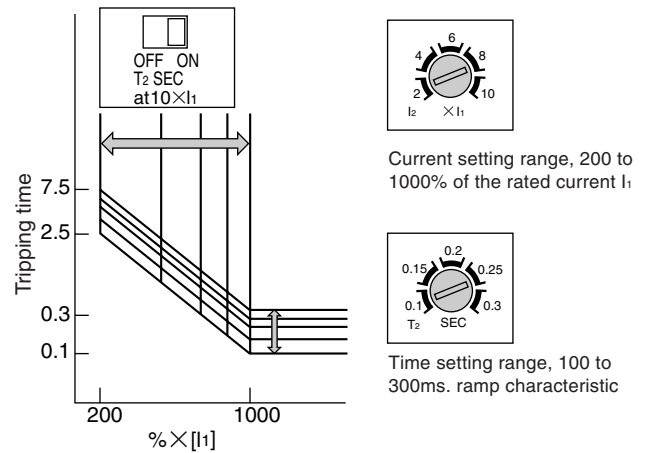

• Adjustable pre-trip alarm

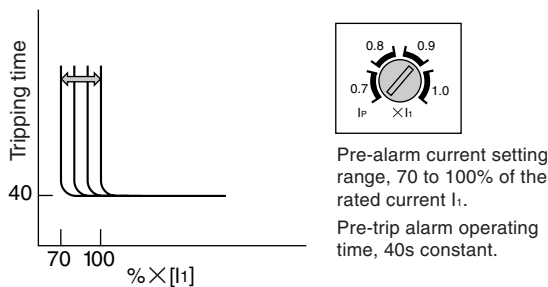

• Adjustable ground fault tripping

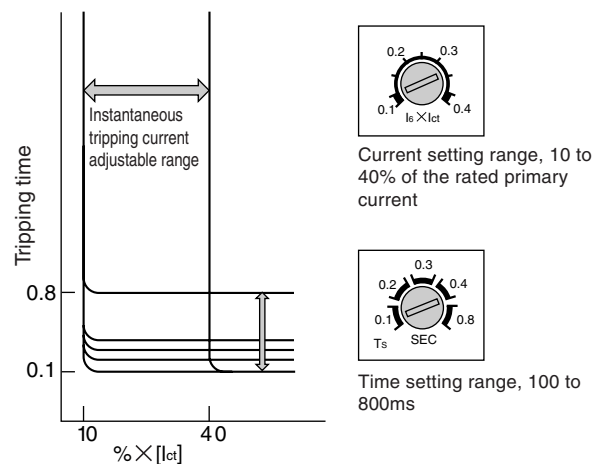

Molded Case Circuit Breakers

Solid-state trip types

■ Pre-trip alarm function

Constantly monitors the load current, and outputs an alarm when it exceeds the set current. Helpful for preventive maintenance and power management. The pre-trip alarm operates via an LED on the breaker surface and a contact output. Separate power supply is necessary. The pre-trip alarm setting range allows adjustment to 70, 80, 90, or 100% of the rated current.

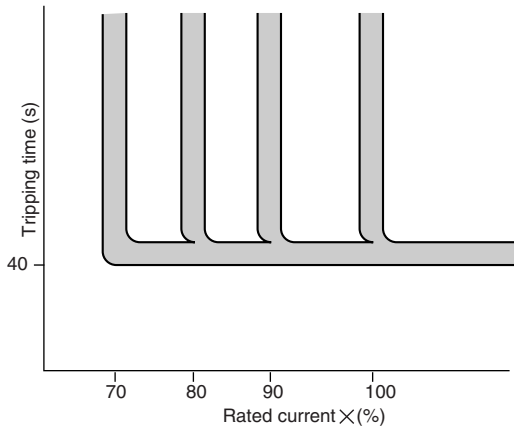

■ Multi protection function

Wide-range-adjustable trip characteristics with high precision. Either ground fault tripping or the pre-trip alarm can be selected as an option (not both).

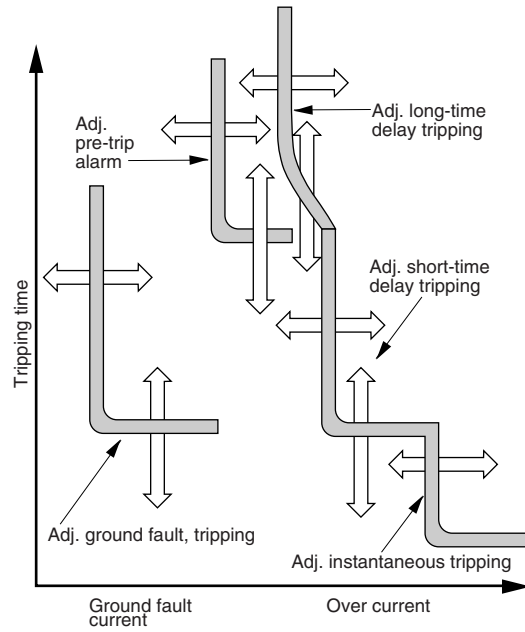

• Pre-trip alarm characteristics

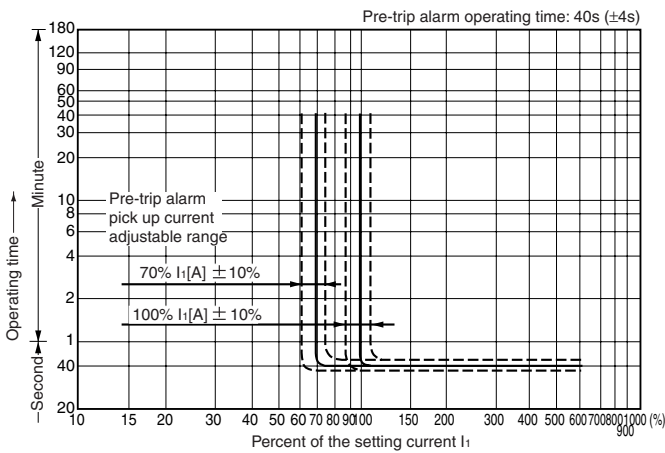

• Ground fault tripping characteristics

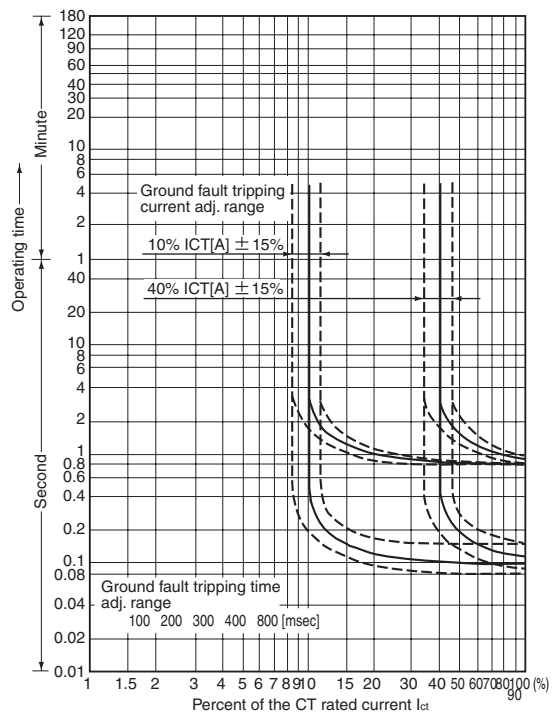

■ Operating characteristic
SA1000E

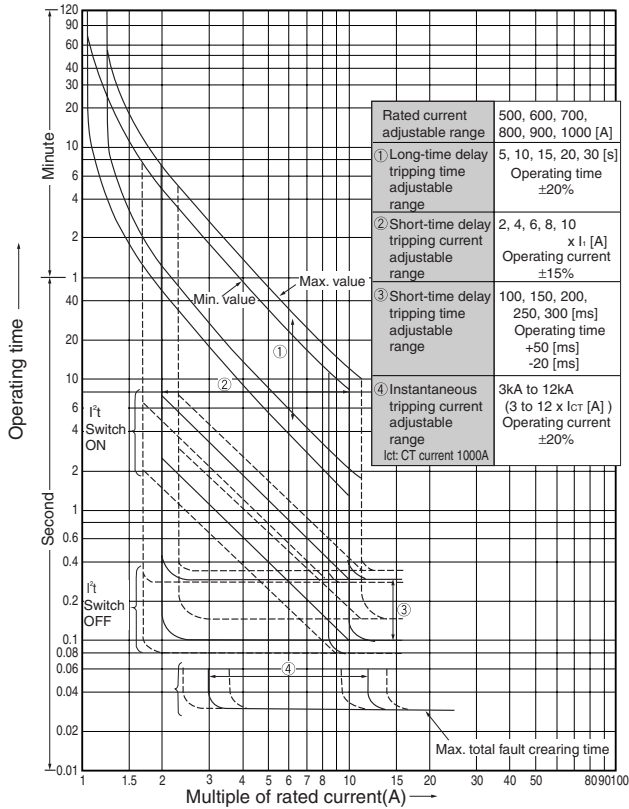

SA1200E

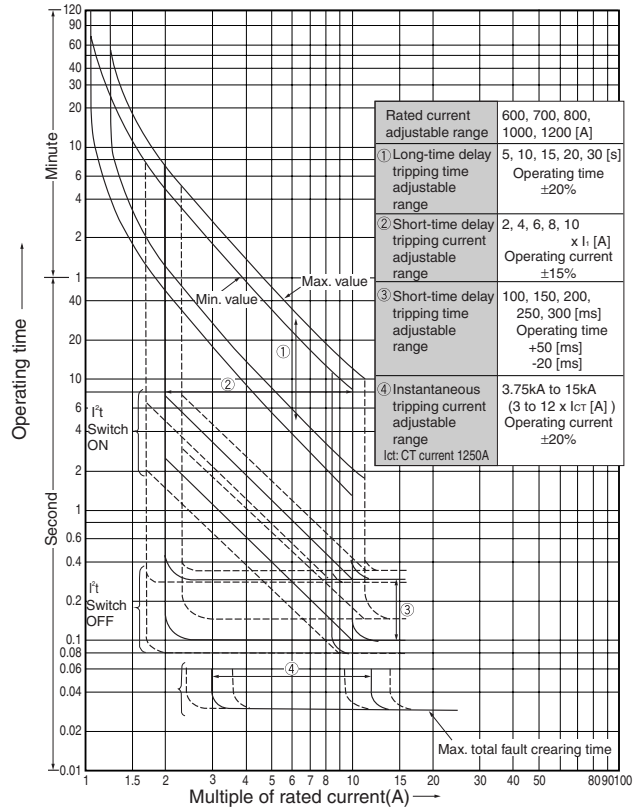

SA1600E

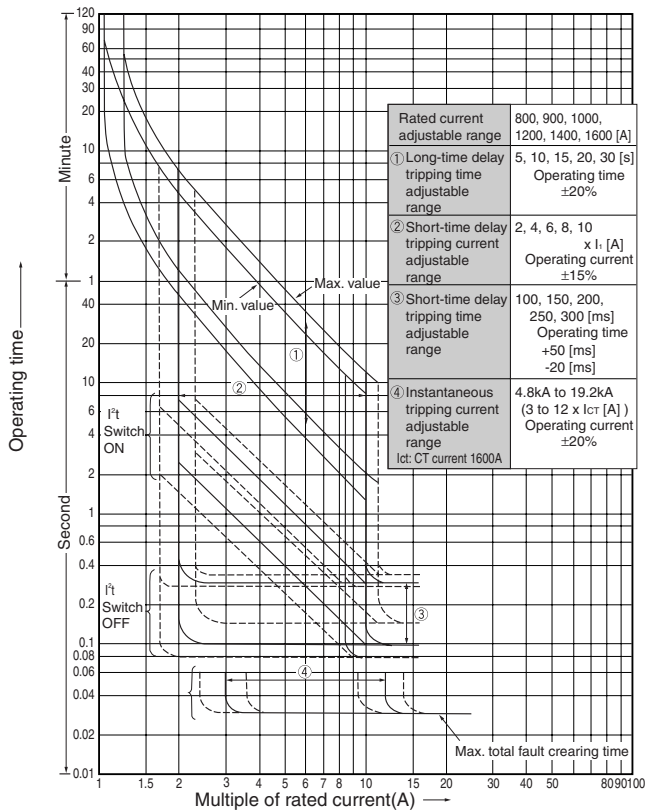

Molded Case Circuit Breakers

Solid-state trip types

■ Dimensions, mm

SA1000E, 1200E

Front mounting, front connection

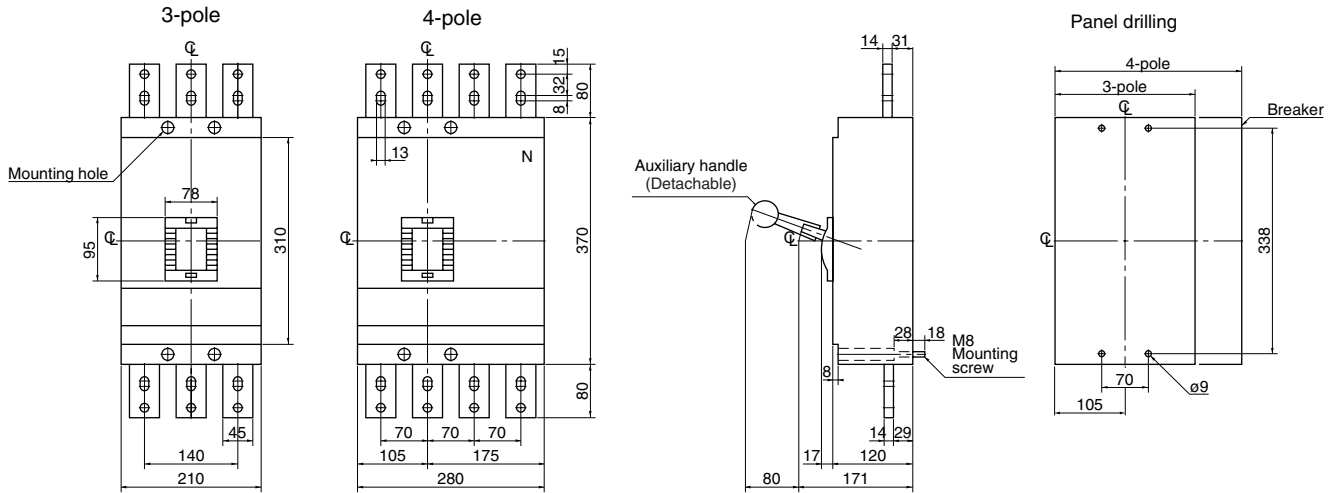

Front mounting, rear connection

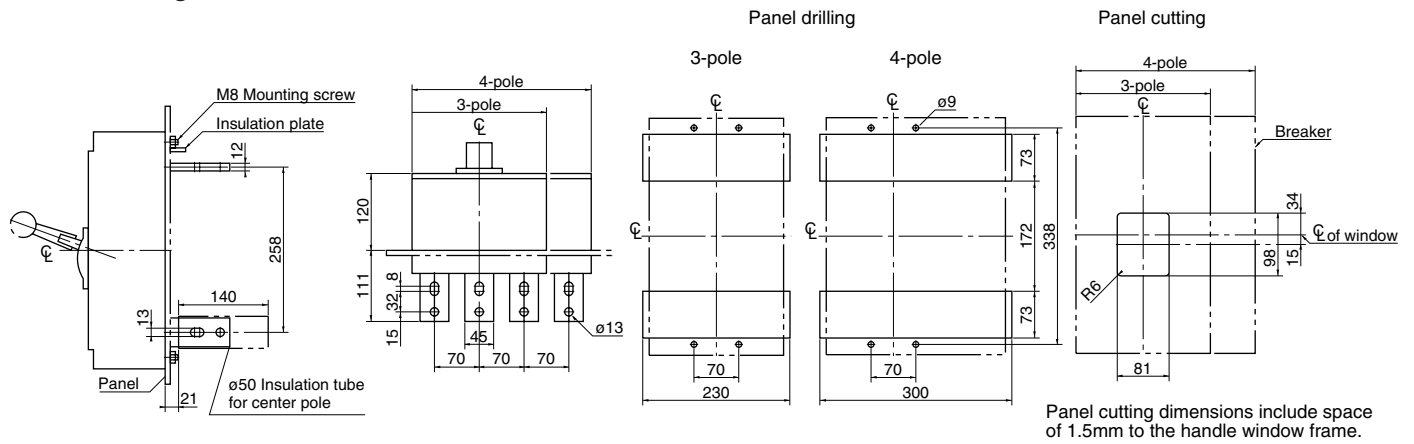

Molded Case Circuit Breakers

CCC approved

■ CCC approved

• MCCB types

Series	AF	2-poles	3-poles	Rated breaking current (Icu/lcs) [kA] *1			Certificate No.
				Ue: 230V AC	Ue: 400V AC	Ue: 440V AC	
S	30	SA32C	SA33C, SA33CM	5/3	2.5/2	2.5/2	2003010307063635
	50	SA52C	SA53C, SA53CM	10/5	7.5/4	7.5/4	2003010307063640
		SA52RC	SA53RC, SA53RCM	25/13	10/5	10/5	2003010307063643
	60	SA62C	SA63C, SA63CM	10/5	7.5/4	7.5/4	2003010307063646
		SA62RC	SA63RC	25/13	10/5	10/5	2003010307063647
	100	SA102C	SA103C	50/25	25/7	–	2004010307116286
		–	SA103CM	50/25	25/7	–	2004010307116286
		SA102RC	SA103RC	100/50	50/13	–	2004010307116286
		–	SA103RCM	100/50	50/13	–	2004010307116286
	225	SA202C	SA203C	50/25	25/7	–	2004010307116273
		–	SA203CM	50/25	25/7	–	2004010307116273
		SA202RC	SA203RC	100/50	50/13	–	2004010307116273
		–	SA203RCM	100/50	50/13	–	2004010307116273
	400	SA402C	SA403C	50/25	35/18	–	2003010307063390
SA402RC		SA403RC	85/43	50/25	–	2003010307063390	
600	–	SA603RC	85/43	50/25	–	2003010307063391	
800	–	SA803RC	85/43	50/25	–	2003010307063391	
E	30	EA32AC	EA33AC, EA33ACM	2.5/2	1.5/1	1.5/1	2003010307063433
	50	EA52AC	EA53AC	2.5/2	1.5/1	1.5/1	2003010307063433
		EA52C	EA53C, EA53CM	5/3	2.5/2	2.5/2	2003010307063635
	60	EA62C	EA63C, EA63CM	5/3	2.5/2	2.5/2	2003010307063385
	100	–	EA103AC	5/3	1.5/1	–	2003010307063440
		EA102C	EA103C, EA103CM	25/13	10/5	10/5	2003010307063647
	225	EA202C	EA203C	35/18	15/4	–	2004010307116273
		–	EA203CM	35/18	15/4	–	2004010307116273
	400	EA402C	EA403C	35/18	25/13	–	2003010307063390
	600	–	EA603C	50/25	35/18	–	2003010307063391
800	–	EA803C	50/25	35/18	–	2003010307063391	

Note: *1 For rated breaking current and rated voltage, the values in this table are approved.

• Internal accessories

SA30AF to 60AF / EA30AF to 100AF

• 2-pole

Available accessory	Type of breaker with accessory	Certificate No.
W (Auxiliary)	SA32C/□■	2003010307063635
K (Alarm)	SA52C/□■	2003010307063640
F (Shunt trip)	SA52RC/□■	2003010307063643
R (Undervoltage trip)	SA62C/□■	2003010307063646
W + K	SA62RC/□■	2003010307063647
W + R	EA32AC/□■	2003010307063433
K + R	EA52AC/□■	2003010307063433
W + K + R	EA52C/□■	2003010307063635
	EA62C/□■	2003010307063385
	EA102C/□■	2003010307063647

• 3-pole

Available accessory	Type of breaker with accessory	Certificate No.
W (Auxiliary)	SA33C/□■	2003010307063635
K (Alarm)	SA53C/□■	2003010307063640
F (Shunt trip)	SA53RC/□■	2003010307063643
R (Undervoltage trip)	SA63C/□■	2003010307063646
W2	SA63RC/□■	2003010307063647
W + K	EA33AC/□■	2003010307063433
K2	EA53AC/□■	2003010307063433
W + K2	EA53C/□■	2003010307063635
W2 + K2	EA63C/□■	2003010307063385
W + F	EA103AC/□■	2003010307063440
W + R	EA103C/□■	2003010307063647
W2 + R		
K + F		
K + R		
K2 + R		
W + K + F		
W + K + R		
W2 + K + R		
W + K2 + R		
W2 + K2 + R		

Notes: • Replace the □ mark by the rated current code.
 • Replace the ■ mark by required accessory code.
 Example Breaker: SA52C with W, K and R } → Type number: SA52C/50WKR
 Rated current: 50A

SA100AF and 225AF / EA225F

• 2-pole / 3-pole

Available accessory	Type of breaker with accessory	Certificate No.
W (Auxiliary)	SA102C/□■	2004010307116286
K (Alarm)	SA103C/□■	
F (Shunt trip)	SA103CM/□■	2004010307116286
R (Undervoltage trip)	SA102RC/□■	
W2	SA103RC/□■	2004010307116273
W + K	SA103RCM/□■	
K2	SA202C/□■	2004010307116278
W + K2	SA203C/□■	
W2 + K2	SA203CM/□■	2004010307116278
W + F	SA202RC/□■	
W + R	SA203RC/□■	2004010307116278
K + F	SA203RCM/□■	
K + R	EA202C/□■	2004010307116278
K2 + R	EA203C/□■	
W + K + F	EA203CM/□■	
W + K + R		

400, 600, 800AF

2-pole / 3-pole

Available accessory	Type of breaker with accessory	Certificate No.
W (Auxiliary)	SA402RC/□■	2003010307063390
K (Alarm)	SA403RC/□■	
F (Shunt trip)	SA603RC/□■	2003010307063391
R (Undervoltage trip)	SA803RC/□■	
W2	EA402C/□■	2003010307063391
W + K	EA403C/□■	
W2 + K	EA603C/□■	2003010307063391
K2	EA803C/□■	
W + K2		2003010307063391
W2 + K2		
W + F		2003010307063391
W + R		
W2 + R		2003010307063391
K + F		
K + R		2003010307063391
K2 + R		
W + K + F		2003010307063391
W + K + R		
K2 + F		2003010307063391
K2 + R		
W2 + K + F		2003010307063391
W2 + K + R		
W + K2 + F		2003010307063391
W + K2 + R		
W2 + K2 + F		2003010307063391
W2 + K2 + R		

Molded Case Circuit Breakers

CCC approved

• External operating handle (optional equipment)

Handle		Applicable type	Certificate No.
N type	V type		
BZ6N10C	BZ6V10C	All types of α -TWIN Series	Certified according to an applicable main body.
BZ6N30C	BZ6V30C	SA102C SA103C SA103CM SA102RC SA103RC SA103RCM	2004010307116286
BZ6N40C	BZ6V40C	SA202C SA203C SA203CM SA202RC SA203RC SA203RCM	2004010307116273
BZ6N40C	BZ6V40C	EA202C EA203C EA203CM	2004010307116273
BZ-N60C	BZ6V60C	SA402C SA403C SA402RC SA403RC EA402C EA403C	2003010307063390
BZ-N70C	BZ6V70C	SA603RC SA803RC EA603C EA803C	2003010307063391

Catalog Disclaimer

The information contained in this catalog does not constitute an express or implied warranty of quality, any warranty of merchantability or fitness for a particular purpose is hereby disclaimed.

Since the user's product information, specific use application, and conditions of use are all outside of Fuji Electric FA Components & Systems' control, **it shall be the responsibility of the user to determine the suitability of any of the products mentioned for the user's application.**

One Year Limited Warranty

The products identified in this catalog shall be sold pursuant to the terms and conditions identified in the "Conditions of Sale" issued by Fuji Electric FA with each order confirmation.

Except to the extent otherwise provided for in the Conditions of Sale issued by Fuji Electric FA, Fuji Electric FA warrants that the Fuji Electric FA products identified in this catalog shall be free from significant defects in materials and workmanship provided the product has not been: 1) repaired or altered by others than Fuji Electric FA; 2) subjected to negligence, accident, misuse, or damage by circumstances beyond Fuji Electric FA's control; 3) improperly operated, maintained or stored; or 4) used in other than normal use or service. This warranty shall apply only to defects appearing within one (1) year from the date of shipment by Fuji Electric FA, and in such case, only if such defects are reported to Fuji Electric FA within thirty (30) days of discovery by purchaser. Such notice should be submitted in writing to Fuji Electric FA at 5-7, Nihonbashi Odemma-cho, Chuo-ku, Tokyo, Japan. The sole and exclusive remedy with respect to the above warranty whether such claim is based on warranty, contract, negligence, strict liability or any other theory, is limited to the repair or replacement of such product or, at Fuji Electric FA's option reimbursement by Fuji Electric FA of the purchase price paid to Fuji Electric FA for the particular product. **Fuji Electric FA does not make any other representations or warranties, whether oral or in writing, expressed or implied, including but not limited to any warranty regarding merchantability or fitness for a particular purpose.** Except as provided in the Conditions of Sale, no agent or representative of Fuji Electric FA is authorized to modify the terms of this warranty in writing or orally.

In no event shall Fuji Electric FA be liable for special, indirect or consequential damages, including but not limited to, loss of use of the product, other equipment, plant and power system which is installed with the product, loss of profits or revenues, cost of capital, or claims against the purchaser or user of the product by its customers resulting from the use of information, recommendations and descriptions contained herein. The purchaser agrees to pass on to its customers and users, in writing at the time inquiries and orders are received by buyer, Fuji Electric FA's warranty as set forth above.

Caution "Safety precautions"

- Operate (keep) in the environment specified in the operating instructions and manual. High temperature, high humidity, condensation, dust, corrosive gases, oil, organic solvents, excessive vibration or shock might cause electric shock, fire, erratic operation or failure.
- Follow the regulations of industrial wastes when the product is to be discarded.
- The products covered in this catalogs have not been designed or manufactured for use in equipment or systems which, in the event of failure, can lead to loss of human life.
- If you intend to use the products covered in this catalog for special applications, such as for nuclear energy control, aerospace, medical, or transportation, please consult our Fuji Electric FA agent.
- Be sure to provide protective measures when using the product covered in these catalogs in equipment which, in the event of failure, may lead to loss of human life or other grave results.
- Follow the directions of the operating instructions when mounting the product.

06 INDIVIDUAL CATALOG

from D&C CATALOG 19th Edition Revised

Fuji Electric FA Components & Systems Co., Ltd.

5-7, Nihonbashi Odemma-cho, Chuo-ku, Tokyo, 103-0011, Japan

URL <http://www.fujielectric.co.jp/fcs/eng>

Information in this catalog is subject to change without notice.



Printed on 100% recycled paper using soy-based ink