

Space-saving Signal Conditioners M3-UNIT Series

STRAIN GAUGE TRANSMITTER

(field- and PC-configurable)

Functions & Features

- Provides a DC output signal proportional to a bridge type strain gauge utilized in load cells and pressure transducers
- Compatibility with strain gauges of various bridge resistances and output ratings
- Supplies required excitation voltage; 0.1 - 10.0 V adjustable
- Response time ≤ 10 msec.
- Front control button function can be locked
- CE marking
- UL approval

Typical Applications

- Weighing system for tanks, hoppers and silos
- Weighing system using cranes
- Pressure sensor utilizing strain gauges
- Float level meter utilizing strain gauges

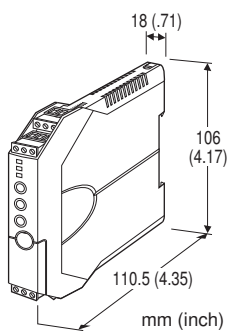

MODEL: M3LLC-[1]-R4/[2][3]

ORDERING INFORMATION

- Code number: M3LLC-[1]-R4/[2][3]

Specify a code from below for each [1] through [3].

(e.g. M3LLC-S1-R4/A)

- Factory setting:

Input signal

S1: 1.0 mV

S2: 3.0 mV

S3: 10.0 mV

S4: 30.0 mV

Excitation voltage: 1 V

Output range: 4 - 20 mA

[1] INPUT STRAIN GAUGE

S1: 0.0 - 1.0 mV/V

S2: 0.0 - 3.0 mV/V

S3: 0.0 - 10.0 mV/V

S4: 0.0 - 30.0 mV/V

OUTPUT - Field-selectable

Current

0 - 20 mA DC

Voltage

-2.5 - +2.5 V DC

-10 - +10 V DC

POWER INPUT

DC Power

R4: 10 - 32 V DC

(Operational voltage range 9 - 36 V, ripple 10 %p-p max.)

[2] CONFIGURATION OPTIONS

A: PC and field configurable

B: Field configurable

[3] OPTIONS

STANDARDS & APPROVALS

blank: CE marking

/UL: UL approval, CE marking

RELATED PRODUCTS

- PC configurator software (model: M3CON)

Downloadable at M-System's web site.

A dedicated cable is required to connect the module to the PC. Please refer to the internet software download site or the users manual for the PC configurator for applicable cable types.

GENERAL SPECIFICATIONS

Construction: Small-sized front terminal structure

Connection: Euro type connector terminal

Housing material: Flame-resistant resin (gray)

Isolation: Input to output to power

Overrange output: -15 to +115 %

Zero adjustment: -15 to +15 % (front)

Span adjustment: 85 to 115 % (front)

Status indicator LED: Tri-color (green/amber/red) LED;

Flashing patterns indicate operation status of the transmitter.

Configuration

PC configurator:

Programmable features include:

- Input range and output type and range
- Zero and span adjustments

(Refer to the instruction manual)

'One-Step Cal' calibration: With I/O type and the full-scale range configured via the internal DIP switches, precise 0 % and 100 % ranges are calibrated via the front control buttons with a help of LED.

INPUT SPECIFICATIONS

■ STRAIN GAUGE INPUT

- Strain Gauge

Rated output from strain gauge:

- S1: Volt. range -10.0 - +10.0 mV, span 1.0 - 10.0 mV
- S2: Volt. range -30.0 - +30.0 mV, span 3.0 - 30.0 mV
- S3: Volt. range -99.9 - +99.9 mV, span 10.0 - 99.9 mV
- S4: Volt. range -300.0 - +300.0 mV, span 30.0 - 300.0 mV

Consult factory for use with a compression/tension load cells.

- **Excitation:** 0.1 - 10.0 V adjustable (0.1 V increments)

Maximum current: 30mA

■ **TARE COMMAND INPUT:** TTL level (5V-CMOS level), open collector or dry contact

(saturation voltage \leq 1 V, sink current 0.5 mA)

OUTPUT SPECIFICATIONS

■ DC CURRENT

Maximum range: 0 - 20 mA DC

Minimum span: 1 mA

(Add 0.1 % to accuracy with output span 2 mA or less.)

Conformance range: 0 - 20 mA DC

(Negative overrange current below 0 mA is not available.)

Offset: Lower range can be any specific value within the output range provided that the minimum span is maintained.

Load resistance: Output drive 12 V maximum

■ DC VOLTAGE

Narrow Spans (mV)

Maximum range: -2.5 - +2.5 V DC

Minimum span: 250 mV

Conformance range: -3 - +3 V DC

Wide Spans (V)

Maximum range: -10 - +10 V DC

Minimum span: 1 V

Conformance range: -11.5 - +11.5 V DC

(Overrange voltage below -11.5 V is not available.)

Offset: Lower range can be any specific value within the output range provided that the minimum span is maintained.

Load resistance: Output drive 10 mA maximum; 5 mA for negative output

INSTALLATION

Power Consumption

- **DC:** Approx. 5 W

Operating temperature: -25 to +65°C (-13 to +149°F)

Max. 55°C (131°F) for UL approval

Operating humidity: 0 to 95 %RH (non-condensing)

Mounting: DIN rail

Weight: 150 g (0.33 lbs)

PERFORMANCE in percentage of span

Accuracy: Input + output

Input: ± 0.1 %

Output: ± 0.1 %

Temp. coefficient: ± 0.015 %/°C (± 0.008 %/°F) of max.

range at -5 to +55°C [23 to 131°F];

± 0.03 %/°C (± 0.02 %/°F) at < -5 °C, $> +55$ °C

Response time: ≤ 10 msec. (0 - 90 %)

Excitation: Set value ± 250 mV

Line voltage effect: ± 0.1 % over voltage range

Insulation resistance: ≥ 100 M Ω with 500 V DC

Dielectric strength: 1500 V AC @ 1 minute

(input to output or power to ground)

500 V AC @ 1 minute (output to power)

STANDARDS & APPROVALS

CE conformity:

EMC Directive (2004/108/EC)

EMI EN 61000-6-4: 2007

EMS EN 61000-6-2: 2005

Approval:

UL/C-UL general safety requirements

(UL 61010-1, CAN/CSA-C22.2 No.1010-1)

EXTERNAL VIEW

FRONT VIEW

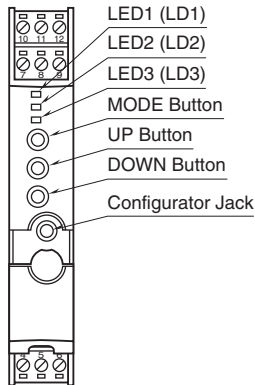

SIDE VIEW

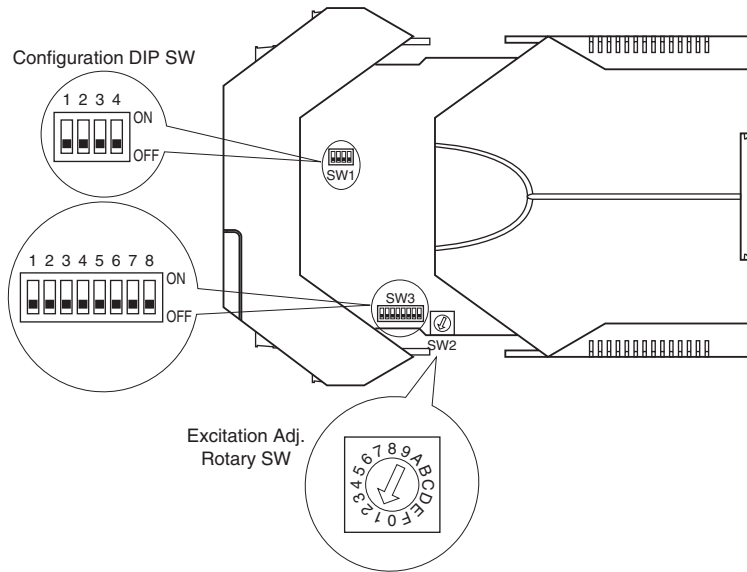

EXTERNAL DIMENSIONS & TERMINAL ASSIGNMENTS unit: mm (inch)

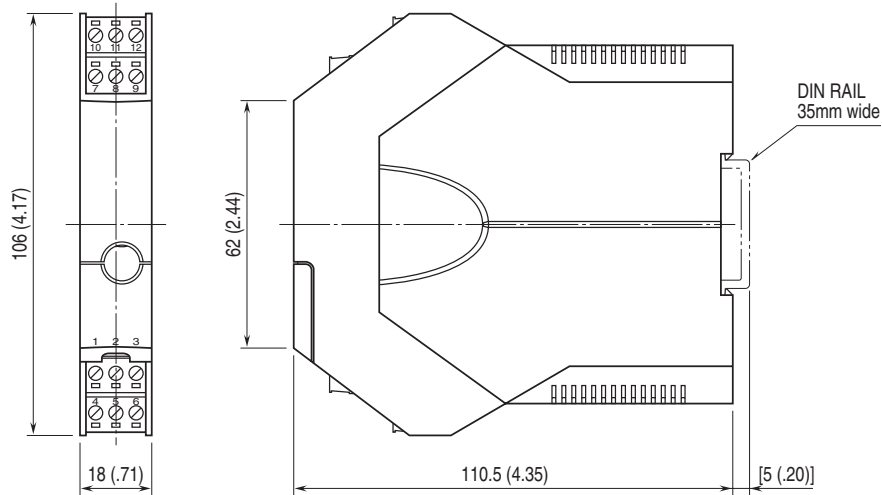

• When mounting, no extra space is needed between units.

SCHEMATIC CIRCUITRY & CONNECTION DIAGRAM

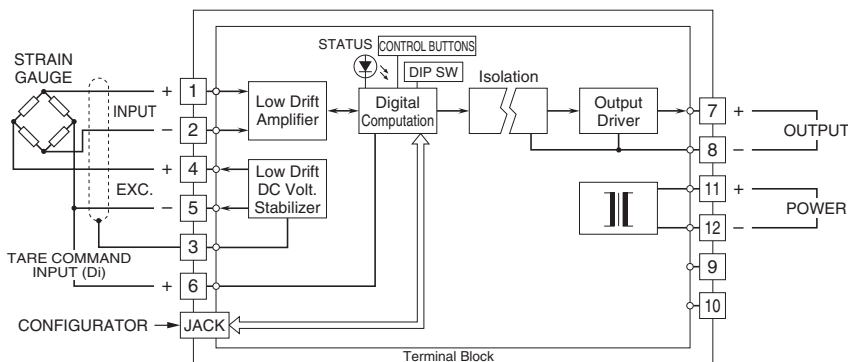



Specifications are subject to change without notice.