



# C2KA

## High Performance PICMG® 2.16 6U CompactPCI® Embedded Computer

### Features

- PICMG 2.16 compliant
- MPC7448 or MPC7447A PowerPC® G4 host processor with 512 KB / 1 MB L2 cache
- MV64460 system controller (Discovery III) bridge chip
- DDR333 SDRAM 1 GB with ECC
- Soldered boot flash 256 MB with multi-level write-protection
- Real-time clock with battery backup from system
- Watchdog from MV64460
- Three 10/100/1000 Ethernet ports
- Two 64-bit IEEE 1386.1 PMC extension slots
- Four async RS-232 or sync/async RS-422 serial I/O ports (COM1, COM2, COM3, COM4)
- Four sync/async RS-422/485 ports (COM5–COM8)
- Three USB 2.0 ports at backplane; additional port at front panel (convection-cooled configuration only)
- Two 1.5 Gbps SATA 1.0 ports
- 16 programmable GPIO ports with independent Interrupts
- Dual temperature sensor
- System and non-system (peripheral) mode
- Ruggedization Level 1 – 5
- Non-RoHS for critical avionics applications
- Temperature range (-40°C to 85°C)

The C2KA is a rugged PICMG 2.16 compliant 6U CompactPCI single board computer (SBC) featuring increased processor speeds, bus speeds and memory capacities make it an excellent choice for advanced defense, aerospace, and homeland security applications.

The C2KA hosts the MPC7448 or the MPC7447A PowerPC G4 processor from Freescale Semiconductor with core processor speeds up to 1.4 GHz and 1 MB of on-board L2 cache. The processor is supported with a 167 MHz MPX System Bus.

The C2KA integrates the Marvell® MV64460 System Controller (Discovery III) bridge chip, which includes a high speed DDR333 SDRAM controller with 167 MHz interface that service memory densities up to 1 GB. It also provides two PCI interfaces: one 64-bit 33/66 MHz PCI bus interface shared with on-board devices and PMC1, and one 64-bit 33/66 MHz PCI/33/66/133 MHz PCI-X Bus interface dedicated to PMC0.

The C2KA features multiple I/O, including three Gigabit Ethernet ports, four RS-232/RS-422 ports, four RS-422/485 ports, two 1.5 Gbps SATA ports, and three high-speed USB 2.0 ports. The convection model also provides one high-speed USB 2.0 port at the front panel.

The C2KA includes 16 programmable GPIO ports with independent interrupts. Each port can be programmed for direction, input polarity, output type, interrupt type (level or edge) and interrupt mask.

The C2KA hosts two 64-bit IEEE1386.1 PMC sites for expanding I/O capability.

For increased flexibility, the PLX PCI 6254 cPCI back plane bridge allows the C2KA to operate as a system controller or peripheral processor card.

The C2KA is available in five ruggedization levels.



# C2KA - High Performance PICMG 2.16 6U CompactPCI Embedded Computer

## Specifications

### Processor

- Motorola MPC7448 PowerPC G4 processor
- Core processor speeds up to 1.4 GHz
- High performance, low power, 32-bit PowerPC RISC architecture
- Superscalar processor
- 32 KB L1 instruction and data caches
- 512 KB L2 on-chip cache
- 64-bit 167 MHz MPX system bus interface to

### DDR SDRAM

- Soldered DDR333 SDRAM
- SDRAM controller from MV64460 system controller
- 64-bit (72-bit with ECC) 167 MHz memory bus
- Capacity: 1 GB

### Flash ROM

- 256 flash memory
- Multi-level write-protection

### PCI Interfaces

- Two PCI bus interfaces from MV64460 system controller
- PCI bus 0: 32/64-bit 33/66 MHz PCI/133 MHz PCI-X (dedicated to PMC0 site)
- PCI bus 1: 32/64-bit 33/66 MHz (shared by PMC1 site, USB controller, SATA controller, and PCI 6254 PCI bridge)
- Both PCI buses configurable VIO (+3.3V or +5V through on-board jumpers)

### 10/100/1000 Ethernet

- Three 10/100/1000BaseT Ethernet port to rear I/O
- MACs provided by the MV64460 system controller
- Independent quad port PHY

### General-Purpose I/O

- 16 programmable GPIO ports
- Programmable for line direction (input, output), input polarity (inverted, non-inverted), output type (TTL, open-drain), interrupt type (edge, level sensitive) and interrupt masking
- +5V tolerant
- Independent interrupts for each port

### USB Ports

- Four USB 2.0 ports: three (USB1-USB3) to cPCI\_J5 (all configurations) and one (USB4) to the front panel (Convection version only)
- Three speeds supported: USB1.0 (1.5 MHz), USB1.1 (12 MHz), and USB2.0 (480 MHz)

### cPCI Backplane Interface

- PCI 6254 cPCI bridge
- PICMG 2.0 R3.0 compliant
- 32/64-bit CompactPCI data transfers at 33/66 MHz
- Auto-detect firmware detects system slot for system controller or peripheral mode

### Serial I/O – RS-232/422

- Two serial ports from multi-protocol serial controller (MPSC) integrated in the MV64460 system controller –COM1, COM2
- Two serial ports from USARTs integrated in the FPGA—COM3, COM4
- COM1, COM2: Two independent serial ports configurable as asynchronous RS-232 or synchronous/asynchronous RS-422 available at cPCI\_J5
- COM3, COM4: Two independent serial ports configurable as asynchronous RS-232 or synchronous/asynchronous RS-422 available at cPCI\_J4
- Software selectable

### Serial I/O – RS-422/485

- Four independently configurable synchronous/asynchronous RS-422/485 serial ports: COM5-COM8 available at cPCI\_4
- USART integrated into FPGA

### Serial ATA (SATA)

- PCI-to-serial ATA host controller on PCI bus 1

### PMC Extension Slots – IEEE P1386/1386.1

- Two VITA 30.1-2001 and ANSI/VITA 20-2001-compliant PMC sites
- PMC0: 64-bit 33/66MHz PCI or 133MHz PCI-X PMC site on dedicated PCI bus 0
- PMC1: 64-bit 33/66MHz PCI PMC site on shared PCI bus 1
- Both PMC sites provide 64-bit user I/O (rear I/O)
- Both PMC sites (PCI busses) VIO configurable to +3.3V or +5V through on-board jumper

### Real-Time Clock

- Real-time clock feature for timekeeping functions
- Battery backup maintained through off-board +3.3V supply (provided by system through backplane (BATT+) pin at cPCI\_J5)

### Watchdog Timer

- MV64460 system controller
- Programmable intervals
- Interrupt and board reset triggers

### Temperature Sensor

- CPU die and ambient temperature
- Software readable from -55°C to +125°C

### Hot Swap

- PICMG2.1 Hot Swap-compliant

### Power Requirements

- +5V, +3.3V—required
- +12V required, -12V optional
- Battery backup for RTC (+3.3 on BATT+)

### Power Allowances – PMC slot

- +5V, +3.3V, ±12V: Total power max. 7.5W per site

### Power Consumption

- Tests performed with 7.5W PMC load

	+5V	+3.3V
<b>Peak:</b> *	5.7A	4.10A
<b>Inrush:</b>	2.0A	2.0A
<b>BATT+:</b>		10µA
<b>Total:</b>	42W	

\* Calculated values

### Mechanical

- PICMG 2.0 R3.0 and VITA 30.1 compliant
- 6U, 1 slot wide
- 233 mm x 160 mm x 20 mm

### Humidity (non-condensing)

- Operating: 5-95% @ 40°C
- Storage 5-95% @ 40°C

### Altitude

- Operating: 4.5 km (15,000 ft.)
- Storage: 12 km (40,000 ft.)

### MTBF

- Calculations are available in accordance with MIL-HDBK-217. Please contact GE Intelligent Platforms for latest values.

### Safety

- Designed to meet standard UL1950/60950

### Emissions

- Designed to meet FCC Part15, SubPart A

## Environmental

	Level 1	Level 2	Level 3	Level 4	Level 5
Cooling Method	Convection	Convection	Convection	Conduction	Conduction
Conformal Coating	Optional	Standard	Standard	Standard	Standard
High/Low Temp	0 to +55° C	-20 to +65° C	-40 to +75° C	-40 to +75° C	-40 to +85° C
Operational	(300 ft/m)	(300 ft/m)	(600 ft/m)	At cold wall	At cold wall
Random Vibration	0.002g <sup>2</sup> /Hz*	0.002g <sup>2</sup> /Hz*	0.04g <sup>2</sup> /Hz**	0.1g <sup>2</sup> /Hz**	0.1g <sup>2</sup> /Hz**
Shock	20g***	20g***	20g***	40g***	40g***

\*With a flat response to 1000 Hz, 6 dB/Oct roll-off from 1000 to 2000 Hz \*\* From 10 to 1000 Hz \*\*\* Peak sawtooth 11 ms duration

## Input/Output

I/O	Front Panel	J3	J4	J5	C2K-TM Rear Panel	C2K-TM On-board
COM1, COM2 (RS-232)				✓	✓	
COM3, COM4 (RS-232)			✓			✓
COM1, COM2, COM3, COM4 (RS-422)			✓			✓
COM5-COM8 (RS-422/485)			✓			✓
10/100/1000BaseT Ethernet (ETH0, ETH1)		✓			✓	
10/100/1000BaseT Ethernet (ETH2)			✓		✓	
GPIO (0-3)			✓			✓
GPIO (4-15)				✓		✓
PMC0 I/O		✓				✓
PMC1 I/O				✓		✓
SATA1-2				✓	✓	
USB1-3				✓	✓	
USB4 (C-style only)	✓					
EM_BOOTSEL# / ROM_WP#				✓		✓

# C2KA - High Performance PICMG 2.16 6U CompactPCI Embedded Computer

## Block Diagram

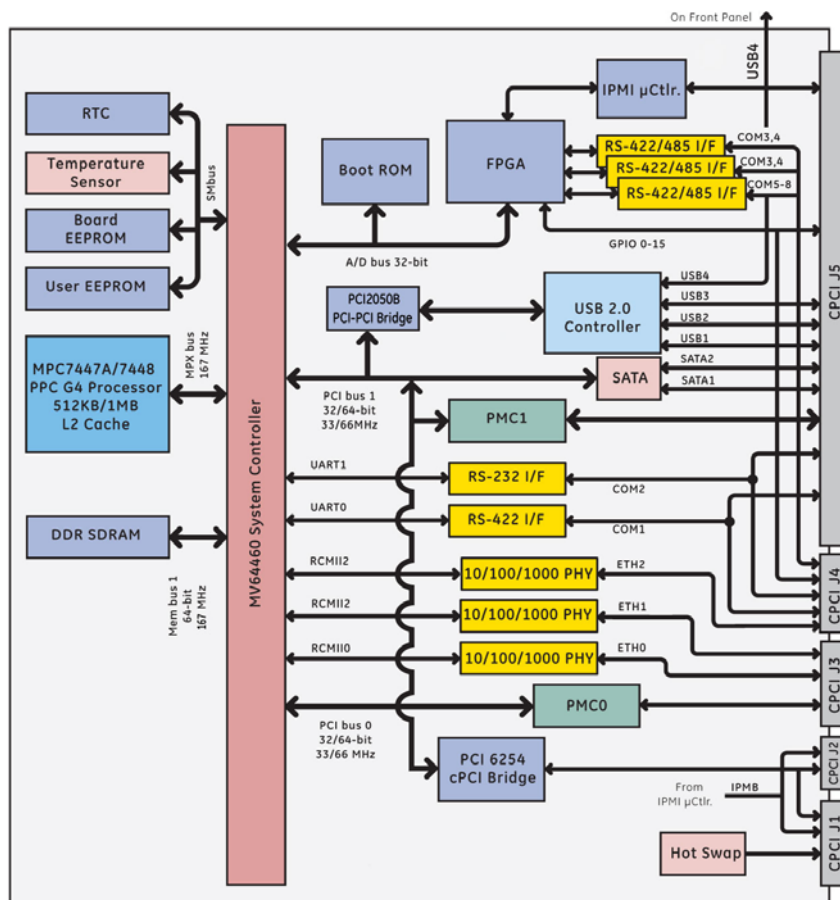

## Ordering Information

### Configuration

**C2KA-112001:** High Performance PICMG 2.16 6U CompactPCI Embedded Computer with MPC7447A processor, 1 GB DRAM, 256 MB Flash, UBOOT Boot ROM, and Level 1 ruggedization. A MPC7448 processor and ruggedization Levels 2 through 5 are available options.

### Hardware Accessories

**C2K-TM:** I/O transition module for 6U backplane

### Operating Systems

VxWorks and Linux Board Support Packages are available. For detailed information and further options, contact GE Intelligent Platforms.

## About GE Intelligent Platforms

GE Intelligent Platforms, a General Electric Company (NYSE: GE), is an experienced high-performance technology company and a global provider of hardware, software, services, and expertise in automation and embedded computing. We offer a unique foundation of agile, advanced and ultra-reliable technology that provides customers a sustainable advantage in the industries they serve, including energy, water, consumer packaged goods, government and defense, and telecommunications. GE Intelligent Platforms is a worldwide company headquartered in Charlottesville, VA and is part of GE Home and Business Solutions. For more information, visit [defense.ge-ip.com](http://defense.ge-ip.com).

## GE Intelligent Platforms Contact Information

Americas: 1 800 433 2682 or 1 434 978 5100

Global regional phone numbers are listed by location on our web site at [defense.ge-ip.com](http://defense.ge-ip.com).

[defense.ge-ip.com](http://defense.ge-ip.com)

