

67C Series Instrument Supply Regulators

- ★ Designed for Digital Instrumentation
- ★ Optional Smart Bleed™ Construction
- ★ Optional Stainless Steel Construction
- ★ Compact and Light Weight
- ★ No Air Loss
- ★ Easy Maintenance
- ★ Optional Integral Filter
- ★ Optional Internal Relief Valve
- ★ Rugged Construction

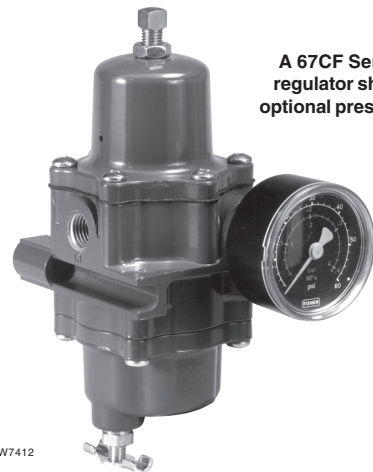

A 67CF Series filter regulator shown with optional pressure gauge

W7412



A 67C Series instrument supply regulator

W8438



A 67CF Series regulator used as a supply regulator for digital instrumentation

W7423_1

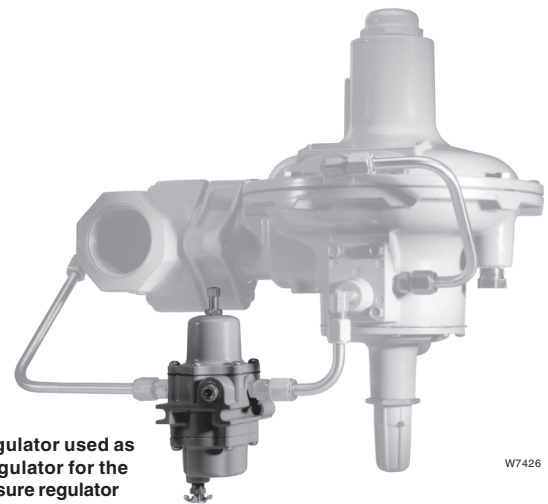

A 67CF Series regulator used as a pilot supply regulator for the Type 299H pressure regulator

W7426



Introduction

The 67C Series regulators are typically used to provide constantly controlled, reduced pressures to pneumatic and electropneumatic controllers and other instruments. These direct-operated regulators are suitable for most air or gas applications. Other applications include providing reduced pressures to air chucks, air jets, and spray guns.

Features

- **Compact**—The 67C Series regulators are engineered for outstanding performance in a compact, light-weight package.
- **Panel Mounting**—Panel mount construction includes spring case with 1/4-inch NPT vent, handwheel adjusting screw, and mounting nut.
- **Instrument Supply Regulator**—The Types 67CF, 67CFR, 67CFS, and 67CFSR provide a clean air supply to a variety of pneumatic and electro-pneumatic instrumentation.
- **Digital Instrument Supply Regulator**—Designed for the accuracy, repeatability, and hysteresis demands of digital instrumentation.
- **Pilot Supply Regulator**—Improves the accuracy of two-path control regulators by reducing inlet sensitivity caused by fluctuating inlet pressures.
- **Pressure Loading Regulator**—Provides accuracy and improved performance in dirty steam service by eliminating the need for a pilot regulator (see figure 3).
- **Sour Gas Service Capability**—NACE MR0175 and MR0103 compliant construction available.
- **Optional Stainless Steel Construction**—The Types 67CS, 67CSR, 67CFS and 67CFSR provide high resistance to corrosion especially beneficial in offshore applications.
- **Full Usable Capacity**—Fisher regulators are laboratory tested. 100 percent of the published capacities can be used with confidence.

- **Internal Relief**—The Types 67CR, 67CSR, 67CFR, and 67CFSR have an internal relief valve with a soft seat for reliable shutoff with no discernible leakage. These regulators are recommended for conserving plant air.
- **Smart Bleed™**—Opens to exhaust downstream pressure when inlet pressure drops below outlet pressure. Recommended for deadend service.
- **Integral Filter**—The Types 67CF, 67CFR, 67CFS, and 67CFSR have an integral filter ensuring clean downstream air supply.
- **Ease of Maintenance**—No special tools are required to perform maintenance, and all maintenance can be performed with the regulator in the line. Filter elements are easily replaced. The one-piece valve plug cartridge allows easy inspection and replacement.
- **Rugged Construction**—The 67C Series regulators are engineered for longer service life with minimal maintenance requirements.
- **Second Outlet**—Body side outlet for pressure gauge or other uses.
- **Powder Paint Coating**—Types 67C, 67CR, 67CF, and 67CFR are powder paint coated, offering impact, abrasion, and corrosion resistance. Stainless steel regulators (Types 67CS, 67CSR, 67CFS and 67CFSR) are not painted.
- **Corrosion Resistant Fasteners**—Bolting and adjusting screw are double zinc-chromated for enhanced corrosion resistance. Optional stainless steel bolting and adjusting screw are also available.

Table 1. Outlet Pressure Ranges and Control Spring Data

Type	OUTLET PRESSURE RANGES, PSIG (bar)	CONTROL SPRING DATA			
		Color	Material	Part Number	Wire Diameter, Inch (mm)
67C, 67CR, 67CF, 67CFR	0 to 20 (0 to 1,4)	green stripe	Music Wire	GE07809T012	0.135 (3,43)
	0 to 35 (0 to 2,4)	silver		T14059T0012	0.156 (3,96)
	0 to 60 (0 to 4,1)	blue stripe		T14058T0012	0.170 (4,32)
	0 to 125 (0 to 8,6)	red stripe		T14060T0012	0.207 (5,26)
67CS, 67CSR, 67CFS, 67CFSR	0 to 35 (0 to 2,4)	silver stripe	Inconel	T14113T0012	0.156 (3,96)
	0 to 60 (0 to 4,1)	blue		T14114T0012	0.172 (4,37)
	0 to 125 (0 to 8,6)	red		T14115T0012	0.207 (5,26)
	0 to 150 (0 to 10,3)	black		10C1730X012	0.250 (6,35)

Specifications

Body Size, Inlet and Outlets Connection Style

1/4-inch NPT

Construction Materials

See Table 2

Maximum Inlet Pressure (Body Rating)⁽¹⁾

All except 67CS and 67CSR: 250 psig (17,2 bar)

Type 67CS and 67CSR: 400 psig (27,6 bar)

Outlet Pressure Ranges

See Table 1

Maximum Emergency Outlet Pressure⁽¹⁾

50 psi (3,4 bar) over outlet pressure setting

Capacities

See Table 3 and Capacity Information section

Wide-Open Flow Coefficients

Main Valve: C_g : 11.7; C_v : 0.36; C_f : 32.2;

Internal Relief Valve: C_g : 1.45; C_v : 0.045; C_f : 32.8

IEC Sizing Coefficients

Main Valve: X_r : 0.66; F_L : 0.89; F_D : 0.50

Accuracy

Inlet Sensitivity: Less than 0.2 psig (0,014 bar) change in outlet pressure for every 25 psig (1,72 bar) change in inlet pressure

Repeatability: 0.1 psig (0,0069 bar)⁽²⁾

Air Consumption: testing repeatedly shows no discernible leakage

Type 67CR, 67CSR, 67CFR, and 67CFSR Internal Relief Performance

Low capacity for minor seat leakage only; other overpressure protection must be provided if inlet pressure can exceed the maximum pressure rating of downstream equipment or exceeds maximum outlet pressure rating of the regulator.

Approximate Unit Weight

Types 67C, 67CR, 67CF, and 67CFR:

1 pound (0,5 kg)

Types 67CS and 67CSR:

2.5 pounds (1,2 kg)

Types 67CFS and 67CFSR:

4 pounds (1,8 kg)

Smart Bleed™ Check Valve Setpoint

6 psi (0,4 bar) differential

Pressure Registration

Internal

Drain Valve and Spring Case Vent Location

Aligned with inlet standard, other positions optional

Regulator Temperature Capabilities

With Nitrile (NBR)

Standard Bolting: -20 to 180°F (-29 to 82°C)

Stainless Steel Bolting: -40 to 180°F (-40 to 82°C)

With Fluoroelastomer (FKM):

0 to 300°F (-18 to 149°C)

With Silicone (VMQ)⁽³⁾ Diaphragm and Low

Temperature bolting: -60 to 180°F (-51 to 82°C)

With Gauges: -20 to 180°F (-29 to 82°C)

Type 67CF, 67CFR, 67CFS, and 67CFSR Filter Capabilities

Free Area: 12 times pipe area

Micron Rating: *Cellulose Element:* 40 microns

Glass Fiber Element: 5 microns

Stainless Steel Element: 40 microns

Options

All Types

- Handwheel adjusting screw
- Inlet screen
- NACE MR0175⁽⁴⁾ or NACE MR0103 construction
- Panel mount (includes spring case with 1/4-inch vent, handwheel, and panel mounting nut)
- Closing cap (available on spring case with 1/4-inch NPT vent)
- Fluoroelastomer (FKM) elastomers for high temperatures and/or corrosive chemicals
- Silicone (VMQ) elastomers for cold temperatures
- Fixed Bleed Restriction
- Triple scale outlet pressure gauge (brass or stainless steel)
- Stainless steel stem on the valve plug
- Tire valve or pipe plug in second outlet

Type 67CFR only

- Smart Bleed™ internal check valve

Types 67CF and 67CFR only

- Stainless steel drain valve

1. The pressure/temperature limits in this bulletin and any applicable standard or code limitation should not be exceeded.

2. Repeatability is the measure of the regulator's ability to return to setpoint consistently when traveling from steady state to transient to steady state.

3. Silicone is not compatible with hydrocarbon gas.

4. Product complies with the material requirements of NACE MR0175. Environmental limits may apply.

Bulletin 71.1:67C

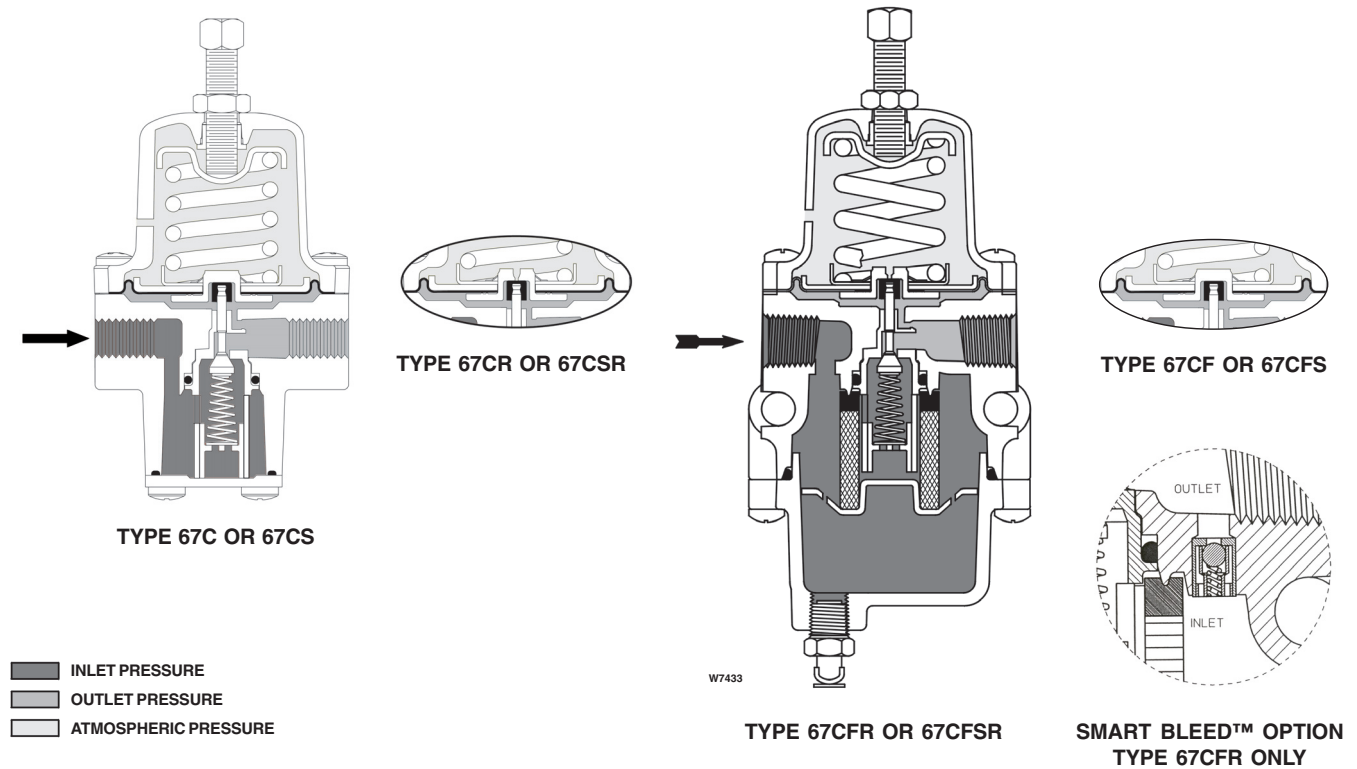

Figure 2. 67C Series Operational Schematics

Table 2. 67C Series Construction Materials

MATERIAL	TYPE			
	67C and 67CR	67CF and 67CFR	67CS and 67CSR	67CFS and 67CFSR
Body and Spring Case	Aluminum (ASTM B85/Alloy 380)		CF8M/CF3M Stainless steel	
Bottom Plate	316 Stainless steel	---	316 Stainless Steel	---
Pusher Post and Valve Cartridge	Polyester resin			
Upper Spring Seat	Zinc-plated Steel		316 Stainless steel	
Lower Spring Seat, Diaphragm Plate	Chromate conversion coated aluminum		316 Stainless steel	
Control Spring	Plated Steel or Inconel (NACE)		Inconel	
Valve Plug	Brass stem with Nitrile plug, Aluminum stem with Nitrile or Fluoroelastomer plug, or Stainless steel stem with Nitrile or Fluoroelastomer plug		316 Stainless steel stem with Nitrile or Fluoroelastomer plug	
Valve Spring	Stainless steel or Inconel (NACE)		Inconel	
Diaphragm and O-Rings	Nitrile, Fluoroelastomer, or Silicone ⁽¹⁾			
Soft Seat and Gaskets	Nitrile or Fluoroelastomer			
Bolting, Adjusting Screw, Locknut	Zinc-plated steel or Stainless steel		316 Stainless steel	
Handwheel	Zinc-plated steel screw with resin handwheel			
Filter Retainer	---	Plated Steel	---	316 Stainless steel
Filter Element	---	Cellulose, Glass fiber, or Stainless steel	---	Glass fiber or 316 Stainless steel
Drain Valve	---	Brass or Stainless steel	---	316 Stainless Steel or 18-8 Stainless steel
Dripwell	---	Aluminum (ASTM B85/Alloy 380)	---	CF8M/CF3M Stainless steel

1. Silicone diaphragm only available with internal relief (67CR, 67CSR, 67CFR, 67CFSR).

Principle of Operation (figure 2)

Downstream pressure is registered internally on the lower side of the diaphragm. When the downstream pressure is at or above the set pressure, the valve plug is held against the orifice and there is no flow through the regulator. When demand increases, downstream pressure drops slightly allowing the spring to extend, moving the stem down and the valve plug away from the orifice. This allows flow through the regulator.

Internal Relief (Types 67CR, 67CSR, 67CFR, and 67CFSR)

If for some reason, outside of normal operating conditions, the downstream pressure exceeds the set point of the regulator, the force created by the downstream pressure will lift the diaphragm until the diaphragm is lifted off the relief seat. This allows flow through the token relief. The relief valve on the Type 67CR, 67CSR, 67CFR, or 67CFSR is an elastomer plug that prevents leakage of air from the downstream to atmosphere during normal operation, thereby conserving plant air.

Smart Bleed™ Airstet

In some cases, it is desired to exhaust downstream pressure if inlet pressure is lost or drops below the setpoint of the regulator. For example, if the regulator is installed on equipment that at times has no flow demand but is expected to backflow on loss of inlet pressure. The Type 67CFR can be ordered with the Smart Bleed™ option which includes an internal check valve for this application. During operation, if inlet pressure is lost, or decreases below the setpoint of the regulator, the downstream pressure will back flow upstream through the regulator and check valve. This option eliminates the need for a fixed bleed downstream of the regulator, thereby conserving plant air.

Overpressure Protection

The 67C Series regulators have maximum outlet pressure ratings that are lower than their maximum inlet pressure ratings. A pressure relieving or pressure limiting device is needed if inlet pressure can exceed the maximum outlet pressure rating. Refer to the Capacity Information section and the Wide-Open Coefficients for Relief Valve Sizing in the Specifications on page 3 to determine the required relief valve capacity.

Type 67CR, 67CSR, 67CFR, and 67CFSR regulators have a low capacity internal relief valve for minor seat

leakage only. Other overpressure protection must be provided if the maximum inlet pressure can exceed the maximum pressure rating of the downstream equipment or exceeds maximum outlet pressure rating of the Type 67CR, 67CSR, 67CFR, or 67CFSR regulator.

Capacity Information

Table 3 shows the air regulating capacities of the 67C Series regulators at selected inlet pressures and outlet pressure settings. Flows are shown in scfh (at 60°F and 14.7 psia) and in m³/h(n) (at 0°C and 1,01325 bar) of air.

Note

The 67C Series regulators may be sized for 100% flow using capacities as shown in table 3. It is not necessary to reduce published capacities.

To determine the equivalent capacities for other gases, multiply the table capacity by the following appropriate conversion factor: 1.29 for 0.6 specific gravity natural gas, 0.810 for propane, 0.707 for butane, or 1.018 for nitrogen. For gases of other specific gravities, divide the table capacities by the square root of the appropriate specific gravity. To find wide-open flow capacities for relief sizing at any inlet pressure, perform one of the following procedures. Then, if necessary, convert using the factors provided above.

For critical pressure drops (absolute outlet pressure equal to or less than one-half of absolute inlet pressure), use the following formula:

$$Q = (P_1)(C_g)$$

For pressure drops lower than critical (absolute outlet pressure greater than one-half of absolute inlet pressure), use the following formula:

$$Q = \sqrt{\frac{520}{GT}} C_g P_1 \text{SIN} \left(\frac{3417}{C_1} \sqrt{\frac{\Delta P}{P_1}} \right) \text{DEG}$$

where,

- Q = gas flow rate, scfh
- P₁ = absolute inlet pressure, psia (P₁ gauge + 14.7)
- C_g = gas sizing coefficient
- G = specific gravity of the gas
- T = absolute temperature of gas at inlet, °Rankine
- C₁ = flow coefficient (C_g ÷ C_v)
- ΔP = pressure drop across the regulator, psi

Then, if capacity is desired in normal cubic meters per hour (at 0°C and 1,01325 bar), multiply scfh by 0.0268.

Bulletin 71.1:67C

Table 3. Capacities

=OUTLET PRESSURE RANGE, SPRING PART NUMBER AND COLOR, PSIG (bar)	OUTLET PRESSURE, PSIG (bar)	INLET PRESSURE, PSIG (bar)	CAPACITIES IN SCFH (m ³ /h(n)) OF AIR			
			Types 67C, 67CR, 67CS, and 67CSR		Types 67CF, 67CFR, 67CFS, and 67CFSR	
			10% Droop	20% Droop	10% Droop	20% Droop
0 to 35 (0 to 2,4) T14059T0012 (Silver) T14113T0012 (Silver Stripe)	15 (1,0)	50 (3,4)	250 (6,70)	430 (11,5)	250 (6,70)	430 (11,5)
		75 (5,2)	340 (9,11)	610 (16,3)	300 (8,04)	690 (18,5)
		100 (6,9)	430 (11,5)	800 (21,4)	330 (8,84)	1000 (26,8)
		150 (10,3)	680 (18,2)	1200 (32,2)	400 (10,7)	1600 (42,9)
		250 (17,2)	1300 (34,8)	1900 (50,9)	450 (12,1)	1800 (48,2)
		400 (27,6) ⁽²⁾	390 (10,5)	1850 (50,0)	----	----
	20 (1,4)	50 (3,4)	310 (8,31)	460 (12,3)	350 (9,38)	500 (13,4)
		75 (5,2)	420 (11,3)	700 (18,8)	530 (14,2)	820 (22,0)
		100 (6,9)	620 (16,6)	940 (25,2)	750 (20,1)	1100 (29,5)
150 (10,3)		960 (25,7)	1450 (38,9)	1400 (37,5)	1600 (42,9)	
35 (2,4)	250 (17,2)	1550 (41,5)	2150 (57,6)	2550 (68,3)	2700 (72,3)	
	400 (27,6) ⁽²⁾	1200 (32,2)	2750 (73,7)	----	----	
	50 (3,4)	390 (10,5)	490 (13,1)	390 (10,5)	500 (13,4)	
	75 (5,2)	590 (15,8)	850 (22,8)	640 (17,1)	820 (22,0)	
0 to 60 (0 to 4,1) T14058T0012 (Blue stripe) T14114T0012 (Blue)	35 (2,4)	100 (6,9)	770 (20,6)	1150 (30,8)	840 (22,5)	1100 (29,5)
		150 (10,3)	1200 (32,2)	1750 (46,9)	1450 (38,9)	1650 (44,2)
		250 (17,2)	2200 (58,9)	2700 (72,3)	2450 (65,6)	2700 (72,3)
		400 (27,6) ⁽²⁾	2850 (76,4)	3450 (92,5)	----	----
		50 (3,4)	310 (8,31)	440 (11,8)	330 (8,84)	470 (12,6)
		75 (5,2)	440 (11,8)	670 (18,0)	500 (13,4)	730 (19,6)
	60 (4,1)	100 (6,9)	560 (15,0)	900 (24,1)	700 (18,8)	1000 (26,8)
		150 (10,3)	780 (20,9)	1350 (36,2)	1050 (28,1)	1550 (41,5)
		250 (17,2)	1450 (38,9)	2200 (59,0)	2000 (53,6)	2600 (69,7)
0 to 125 (0 to 8,6) T14060T0012 (Red stripe) T14115T0012 (Red)	80 (5,5)	400 (27,6) ⁽²⁾	770 (20,6)	2500 (67,0)	----	----
		75 (5,2)	520 (13,9)	720 (19,3)	520 (13,9)	720 (19,3)
		100 (6,9)	750 (20,1)	1050 (28,1)	770 (20,6)	1000 (26,8)
		150 (10,3)	1100 (29,5)	1700 (45,6)	1100 (29,5)	1600 (42,9)
		250 (17,2)	2050 (54,9)	2850 (76,4)	2450 (65,6)	2750 (73,7)
		400 (27,6) ⁽²⁾	3200 (85,8)	4300 (115)	----	----
	125 (8,6)	150 (10,3)	900 (24,1)	1250 (33,5)	900 (24,1)	1150 (30,8)
		250 (17,2)	1560 (41,8)	2450 (65,6)	1650 (44,2)	2450 (65,6)
		400 (27,6) ⁽²⁾	2200 (59,0)	4350 (117)	----	----
0 to 150 (0 to 8,6) ⁽¹⁾ 10C1730X012 (Black)	80 (5,5)	250 (17,2)	550 (14,7)	1200 (32,2)	550 (14,7)	1200 (32,2)
		400 (27,6) ⁽²⁾	400 (10,7)	1100 (29,5)	----	----
	135 (9,3)	250 (17,2)	970 (26,0)	1800 (48,2)	1100 (29,5)	1800 (48,2)
		400 (27,6) ⁽²⁾	840 (22,5)	2350 (63,0)	----	----
	150 (10,3)	250 (17,2)	1100 (29,5)	1850 (49,6)	1100 (29,5)	1850 (49,6)
		400 (27,6) ⁽²⁾	940 (25,2)	2500 (67,0)	----	----

1. Available for Types 67CS, 67CSR, 67CFS and 67CFSR only

2. Inlet pressures above 250 psig (17,2 bar) with a maximum of 400 psig (27,6 bar) only available on Types 67CS and 67CSR.

670 Series Panel-Mounted Loading Regulators (figure 4)

The 670 Series panel-mounted loading regulators are compact, rugged units used primarily for manually loading pressure-balanced gas regulators and providing manual control for diaphragm actuator control valves. Applications include remote control of gas pressure to burners in refineries, power plants, and various process furnaces.

Three basic panels are available within the product line, each having one 67C Series pressure regulator

connected to one or two gauges and a changeover valve. A single gauge typically shows loading pressure to the control valve. For more information see bulletin 62.3:670.

Ordering Information

When ordering, complete the Ordering Guide on page 12. Refer to the Specifications on page 3. Review the description to the right of each specification and the information in each referenced table or figure. Specify your choice whenever a selection is offered.

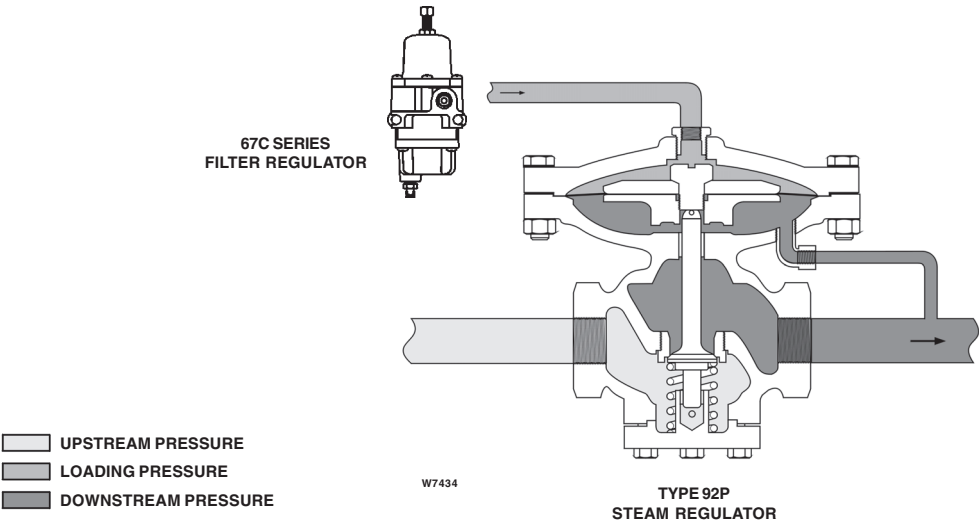

A 67C SERIES PRESSURE LOADING REGULATOR USED WITH THE TYPE 92P STEAM REGULATOR ELIMINATES THE NEED FOR A PILOT REGULATOR. THIS PROVIDES HIGH ACCURACY AND IMPROVED PERFORMANCE IN DIRTY STEAM SERVICE.

Figure 3. 67C Series Regulator Used to Pressure Load a 92P Steam Regulator



1-GAUGE PANEL

2-GAUGE PANEL

2-GAUGE PANEL WITH
CHANGEOVER VALVE

Figure 4. 670 Series Typical Panel Layouts

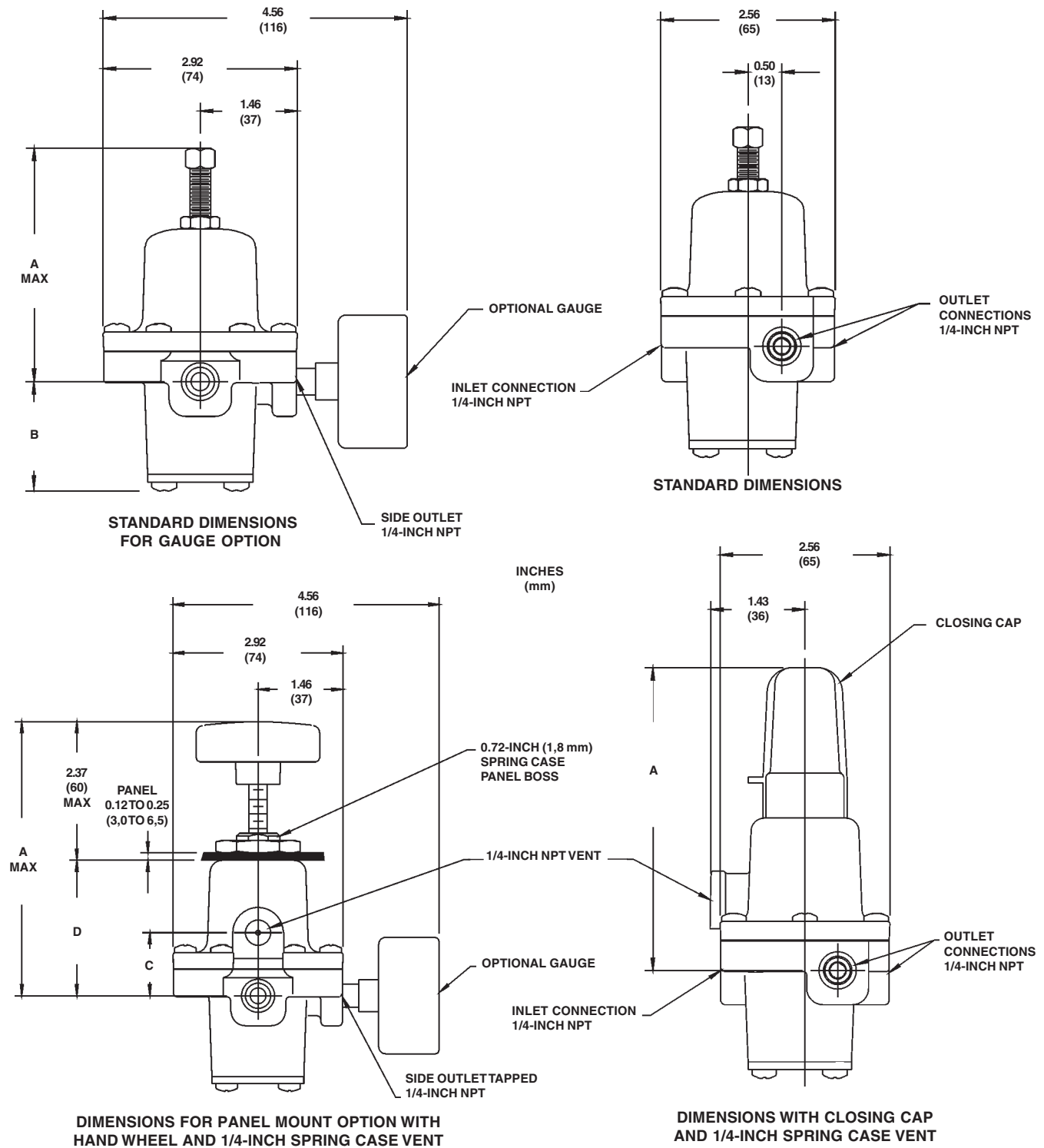

TYPE	STANDARD DIMENSIONS		DIMENSION WITH CLOSING CAP	PANEL MOUNT OPTION WITH HANDWHEEL DIMENSIONS		
	A	B	A	A	C	D
67C, 67CR	3.50 (89)	1.51 (38)	4.60 (117)	4.69 (119)	1.08 (27)	2.33 (59)
67CS, 67CSR	4.13 (105)	1.62 (41)	4.93 (125)	5.00 (127)	1.14 (29)	2.65 (67)

Figure 5. Types 67C, 67CR, 67CS, and 67CSR Dimensions

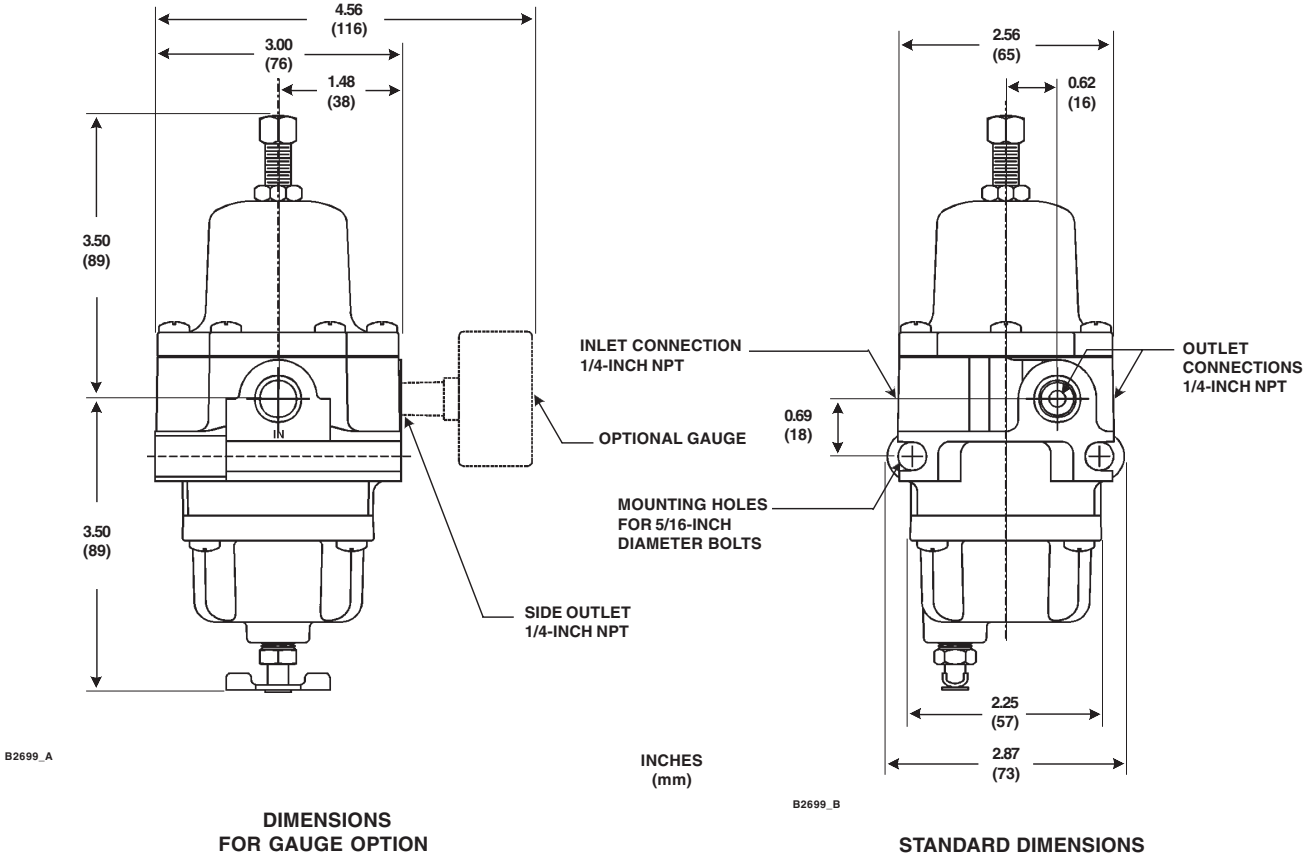

Figure 6. Types 67CF and 67CFR Dimensions

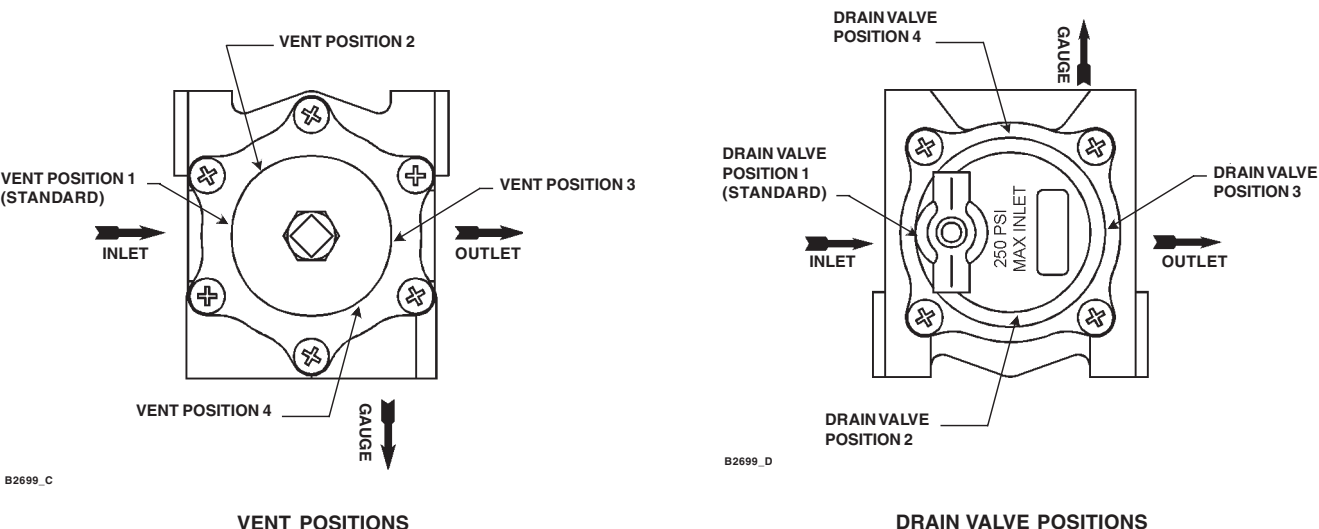

Figure 7. 67C Series Vent and Drain Valve Positions

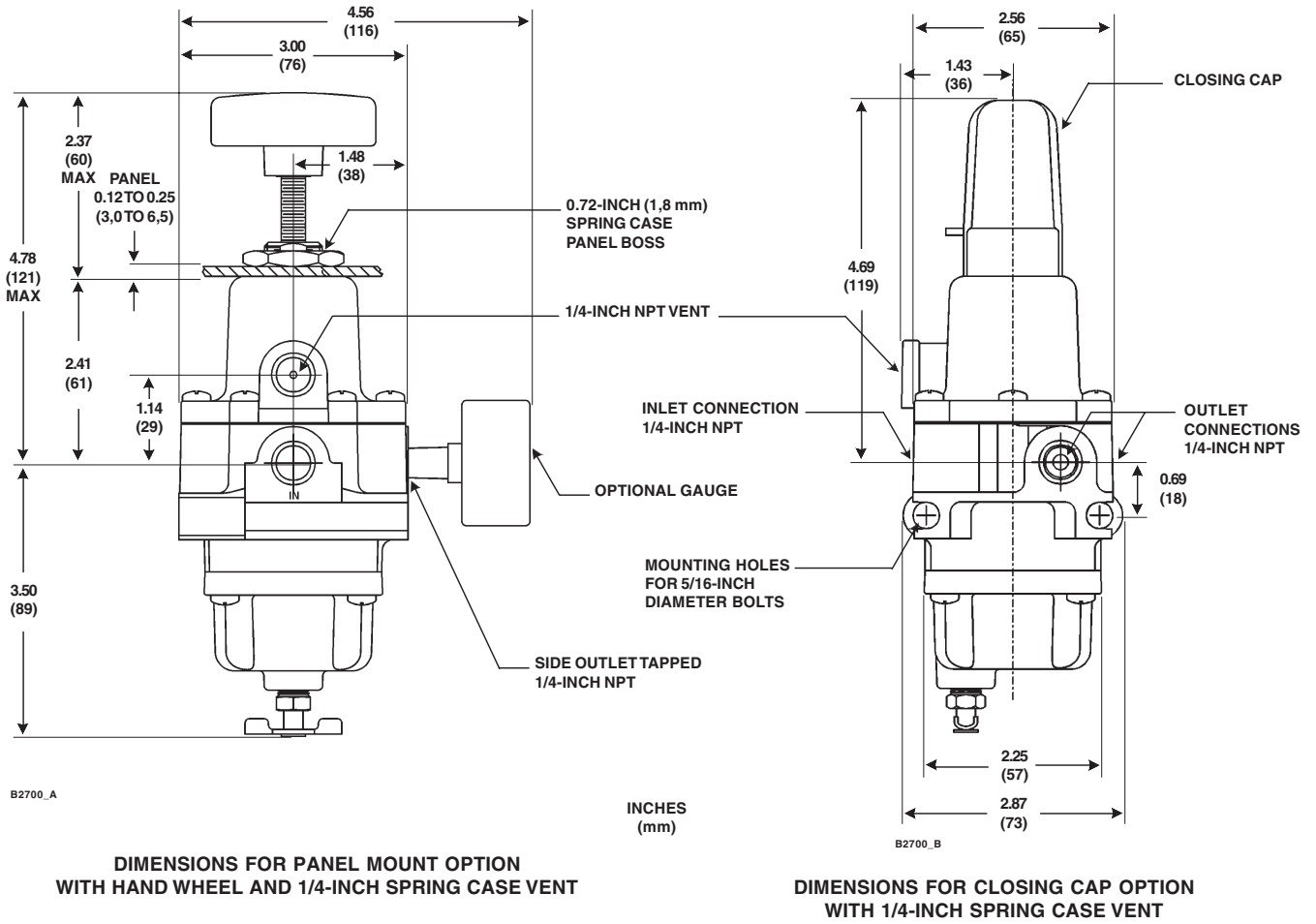

Figure 8. Types 67CF and 67CFR Dimensions (continued)

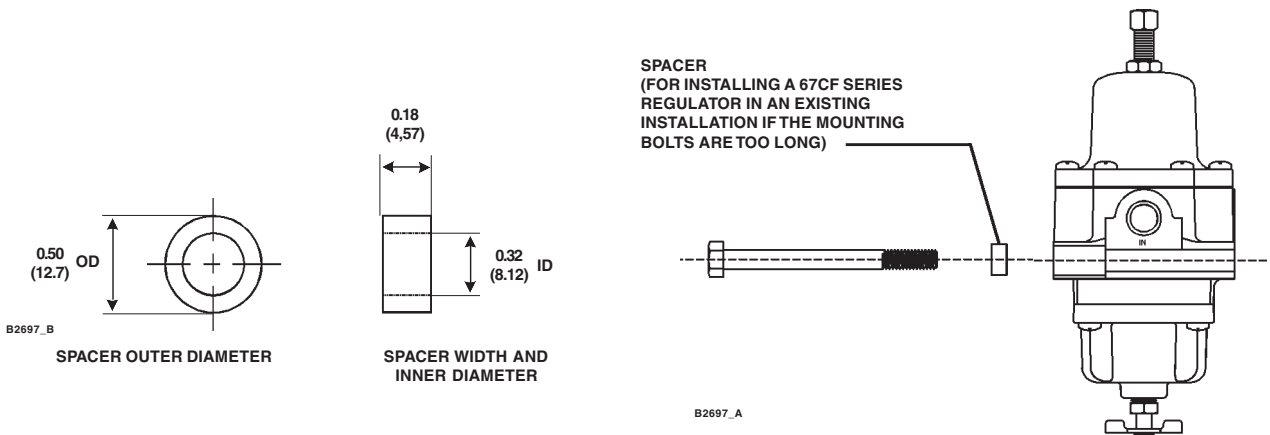
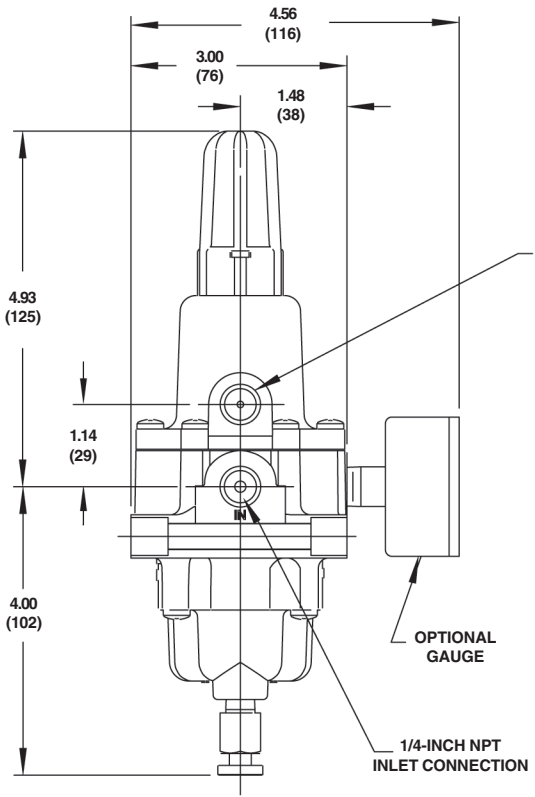
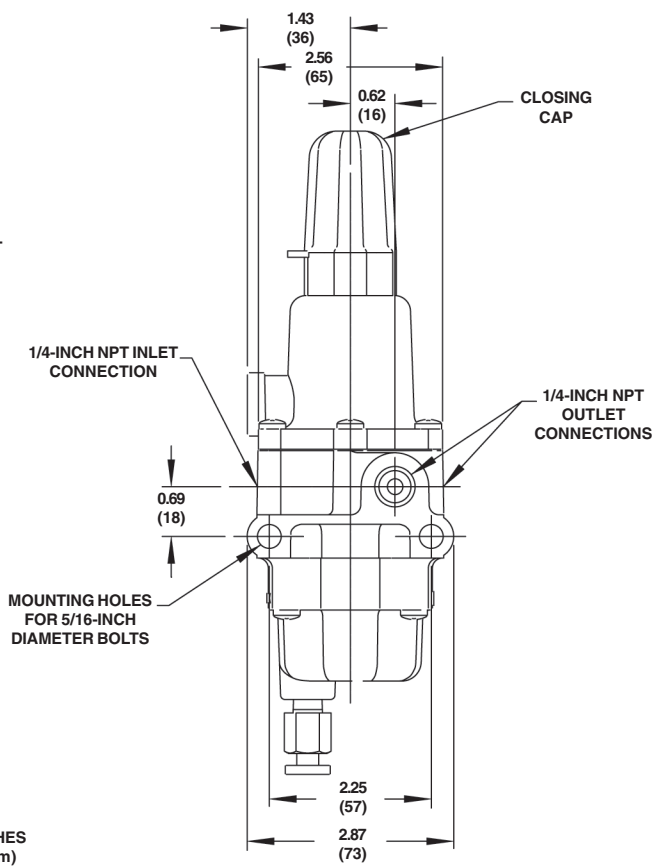

Figure 9. Spacer Dimensions and Installation Schematic



STANDARD DIMENSIONS (INCLUDING CLOSING CAP)



INCHES (mm)

STANDARD DIMENSIONS (INCLUDING CLOSING CAP)

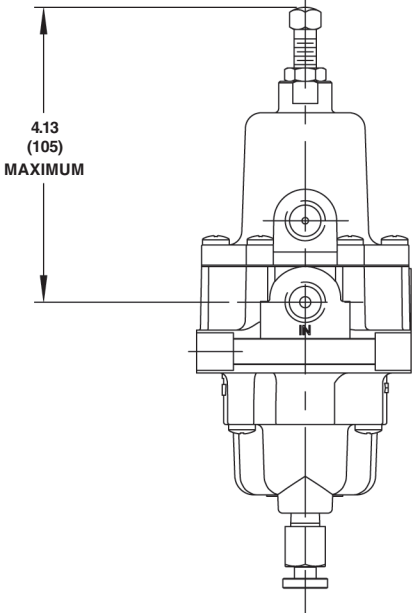

DIMENSIONS WITHOUT CLOSING CAP

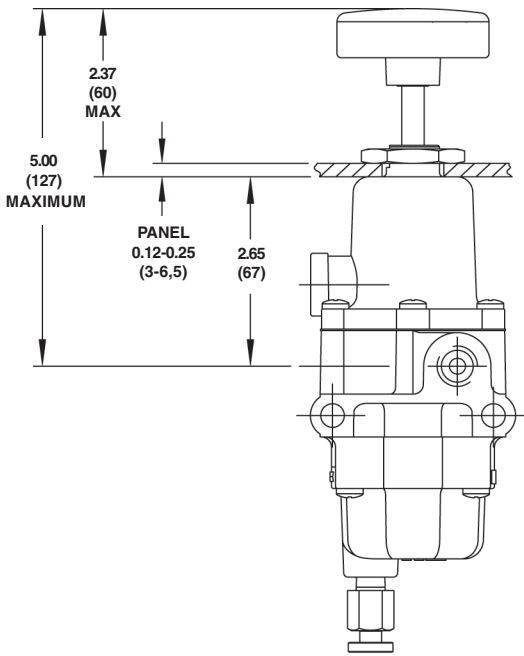

INCHES (mm)

DIMENSIONS FOR PANEL MOUNT OPTION WITH HANDWHEEL

Figure 10. Types 67CFS and 67CF SR Dimensions

Bulletin 71.1:67C

Ordering Guide

Type (Select One)

- Type 67C (aluminum without internal relief)***
- Type 67CR (aluminum with internal relief)***
- Type 67CS (stainless steel without internal relief)***
- Type 67CSR (stainless steel with internal relief)***
- Type 67CF (aluminum with filter and without internal relief)***
- Type 67CFR (aluminum with filter and internal relief)***
- Type 67CFS (stainless steel with filter and without internal relief)***
- Type 67CFSR (stainless steel with filter and internal relief)***

Quantity (Specify) _____

Spring Case Style (Select One)

- Drilled hole vent (67C, 67CR, 67CF, 67CFR standard)***
- 1/4-inch NPT vent (67CS, 67CSR, 67CFS, 67CFSR standard)***
- Single hole panel mount***

Adjusting Screw (Select One)

- Square head (67C, 67CR, 67CF, 67CFR standard)***
- Square head with closing cap (67CS, 67CSR, 67CFS, 67CFSR standard)***
- Handwheel***

Outlet Pressure Range (Select One)

- 0 to 20 psig (0 to 1,4 bar)***
- 0 to 35 psig (0 to 2,4 bar)***
- 0 to 60 psig (0 to 4,1 bar)***
- 0 to 125 psig (0 to 8,6 bar)***
- 0 to 150 psig (0 to 10,3 bar) (67CS, 67CSR, 67CFS, 67CFSR only)***

Diaphragm, O-Rings, and Valve Plug (Select One)

- Nitrile (NBR) (standard)***
- Fluoroelastomer (FKM)**
- Silicone (VMQ) diaphragm, O-rings, and nitrile valve plug*

Filter Material (Select One)

- Cellulose (40 microns)(67CF, 67CFR standard)***
- Glass (5 microns)***
- Stainless steel (40 microns)(67CFS, 67CFSR standard)***

Drain Valve (Select One)

- Brass (67CF, 67CFR standard)***
- Stainless steel (67CFS, 67CFSR standard)***

Drain Valve Location (Select One)

- Position 1 - Aligned with inlet (standard)***
- Position 2
- Position 3
- Position 4

Fisher Regulators Quick Order Guide	
***	Standard - Readily Available for Shipment
**	Non-Standard - Allow Additional Time for Shipment
*	Special Order, Constructed from Non-Stocked Parts. Consult Your Fisher Sales Representative for Availability.
Availability of the product being ordered is determined by the component with the longest shipping time for the requested construction.	

Spring Case Vent Location (Select One)

- Position 1 - Aligned with inlet (standard)***
- Position 2
- Position 3
- Position 4

Fixed Bleed for Type 67CR, 67CSR, 67CFR, or 67CFSR (Optional)

- Yes**

Smart Bleed™ Internal Check Valve Airset (Optional - 67CFR only)

- Yes**

Second Outlet (Select One)

- Open (67C, 67CR, 67CF, 67CFR standard)***
- Plugged with pipe plug (67CS, 67CSR, 67CFS, 67CFSR standard)***
- Tire Valve***
- Pressure Gauge (see below)

Triple Scale Pressure Gauge (Optional)

- Brass Gauge or Stainless Steel Gauge
 - 0 to 30 psig/0 to 0.2 MPa/0 to 2 bar***
 - 0 to 60 psig/0 to 0.4 MPa/0 to 4 bar***
 - 0 to 160 psig/0 to 1.1 MPa/0 to 11 bar***

NACE MR0175 Construction (Optional)⁽¹⁾

- Yes (not available with gauge)**

1. Product complies with the material requirements of NACE MR0175. Environmental limits may apply.

NACE MR0103 Construction (Optional)

- Yes (not available with gauge)**

Replacement Parts Kit (Optional)

- Yes, send one replacement parts kit to match this order.

Specification Worksheet

Application (Please designate units):
 Specific Use _____
 Line Size _____
 Gas Type and Specific Gravity _____
 Gas Temperature _____
 Does the Application Require Overpressure Protection?
 No Yes, if so, which is preferred:
 Relief Valve Monitor Regulator Shutoff Device
 Is overpressure protection equipment selection assistance desired? _____

Pressure (Please designate units):
 Maximum Inlet Pressure (P_{1max}) _____
 Minimum Inlet Pressure (P_{1min}) _____
 Downstream Pressure Setting(s) (P_2) _____
 Maximum Flow (Q_{max}) _____

Performance Required:
 Accuracy Requirements? _____
 Need for Extremely Fast Response? _____

Other Requirements: _____

Fisher is a mark owned by Fisher Controls International, Inc., a business of Emerson Process Management. The Emerson logo is a trademark and service mark of Emerson Electric Co. All other marks are the property of their respective owners.

The contents of this publication are presented for informational purposes only, and while every effort has been made to ensure their accuracy, they are not to be construed as warranties or guarantees, express or implied, regarding the products or services described herein or their use or applicability. We reserve the right to modify or improve the designs or specifications of such products at any time without notice.

Fisher does not assume responsibility for the selection, use or maintenance of any product. Responsibility for proper selection, use and maintenance of any Fisher product remains solely with the purchaser.

For information, contact Fisher:

Marshalltown, Iowa 50158 USA
 McKinney, Texas 75070 USA
 28320 Gallardon, France
 40013 Castel Maggiore (BO), Italy
 Sao Paulo 05424 Brazil
 Singapore 128461

