

Address:
Block 9, Shuiwei Ind Zone, Shuiwei New
Village, Dalang, Longhua, Shenzhen,
Guangdong, China 518109

Tel: (86)755-28121370/ 28121371/28109416/28109419
Fax: (86)755-28109417
E-mail: rd@horn.com.cn
Website: www.horn.com.cn

CUSTOMER : Digi-Key Corporation

APPROVAL SHEET

PRODUCT NAME	PART NUMBER	DIMENSION	REMARK
Electret Condenser Microphone	EM4513-50BC10&33	$\phi 4.5 \times 1.3(\text{mm})$	SMT

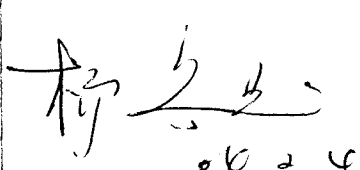
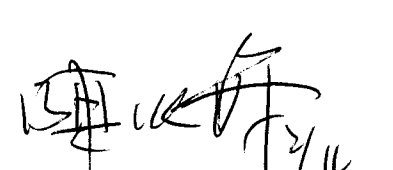
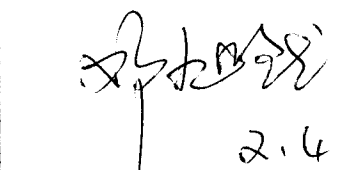
APPROVED BY	CHECKED BY	ISSUED BY
 06.2.4	 2/4	 2.4

APPROVED BY

DATE:

Address:
Block 9, Shuiwei Ind Zone, Shuiwei New
Village, Dalang, Longhua, Shenzhen,
Guangdong, China 518109

Tel: (86)755-28121370/ 28121371/28109416/28109419
Fax: (86)755-28109417
E-mail: rd@horn.com.cn
Website: www.horn.com.cn

SPECIFICATION

Item	Symbol	Test conditions	Min	Standard	Max	Unit
Sensitivity	S	$f=1\text{KHz}, P_{in}=1\text{Pa}$	-54	-50	-46	dB <small>(dB=1V/Pa)</small>
Directivity	Omnidirectional					
Impedance	Zout				2.2	K Ω
Input sound Pressure level	S.P.L				100	dB
Operation voltage	Vs	-	1.0	2	10	V
Current consumption	I	$f=1\text{KHz}, P_{in}=1\text{Pa}$			500	μA
Sensitivity reduction	ΔS	$f=1\text{KHz}, P_{in}=1\text{Pa}$ $V_s=2 \rightarrow 1.5\text{V}$			-3	dB
S/N ratio	S/N(A)	$f=1\text{KHz}, P_{in}=1\text{Pa}$ A=curve	58			dB

Measurement Circuit (Test Condition $V_s=2\text{V}$ $R_L=2.2\text{K}\Omega$

$T_a=20^\circ\text{C}$ $R.H=65\%$)

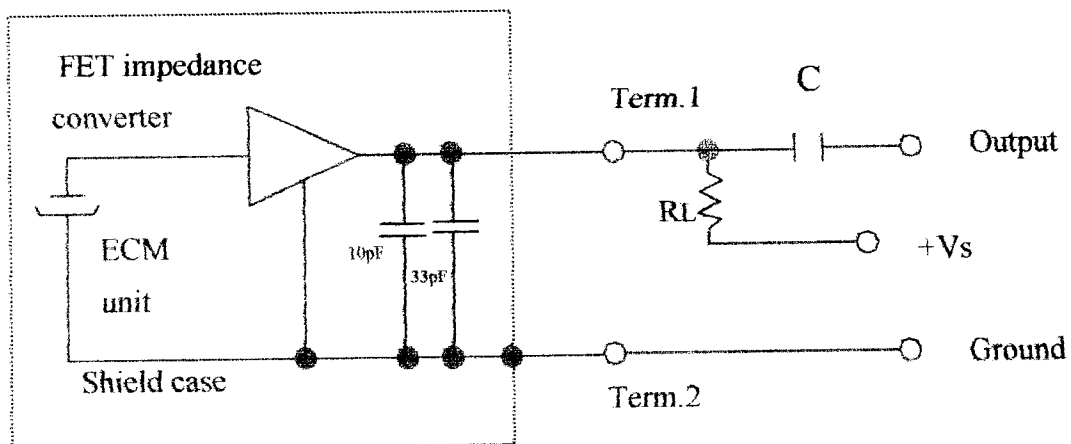

Address:
Block 9, Shuiwei Ind Zone, Shuiwei New
Village, Dalang, Longhua, Shenzhen,
Guangdong, China 518109

Tel: (86)755-28121370/ 28121371/28109416/28109419
Fax: (86)755-28109417
E-mail: rd@horn.com.cn
Website: www.horn.com.cn

Dimensional Drawing

unit: mm

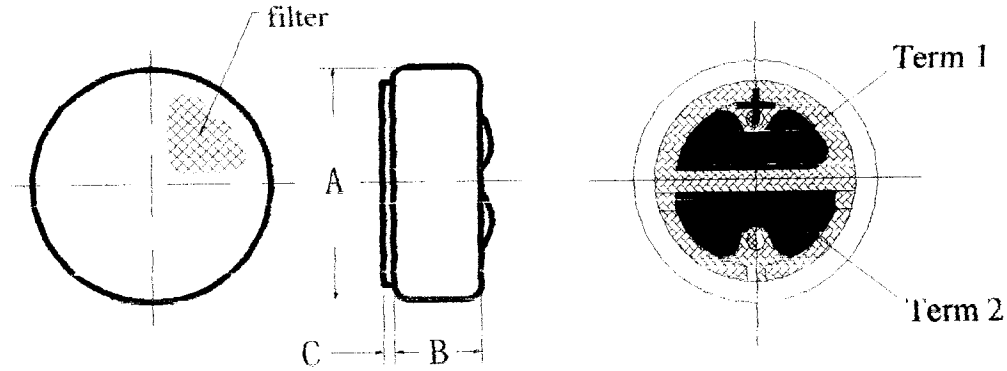

PART	MIN	STANDARD	MAX	REMARK
A	φ 4.3	φ 4.5	φ 4.7	
B	1.2	1.3	1.4	
C	0.1	0.2	0.3	

Typical Frequency Response Curve

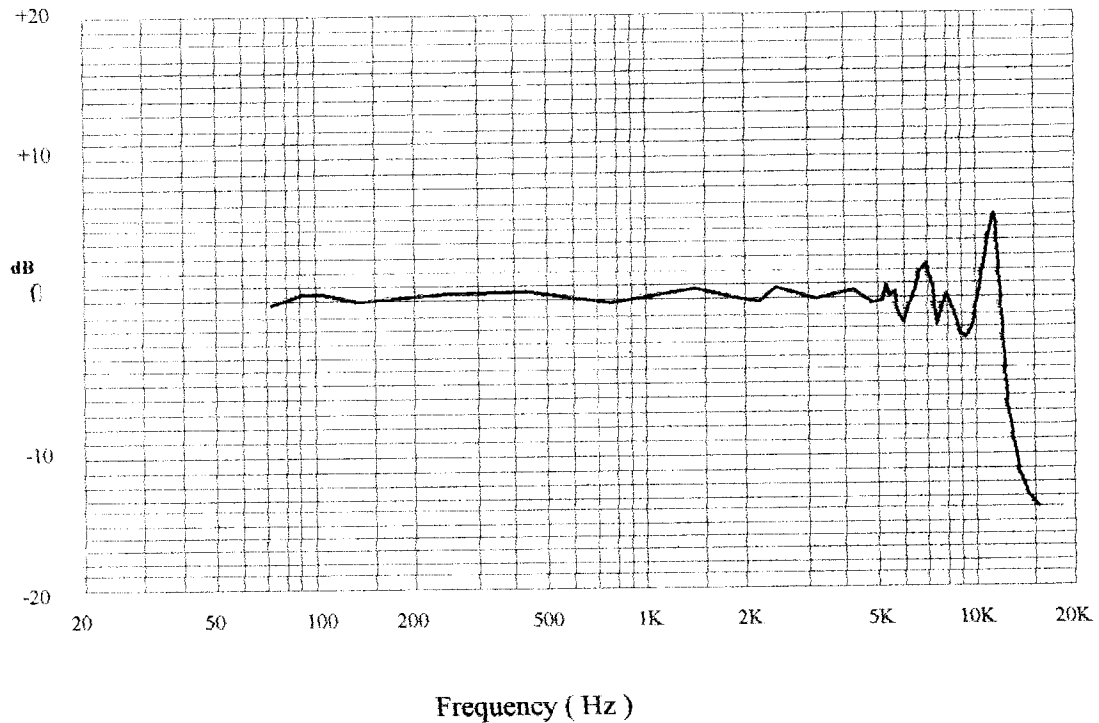

Address:
Block 9, Shuiwei Ind Zone, Shuiwei New
Village, Dalang, Longhua, Shenzhen,
Guangdong, China 518109

Tel: (86)755-28121370/ 28121371/28109416/28109419
Fax: (86)755-28109417
E-mail: rd@horn.com.cn
Website: www.horn.com.cn

Ambient condition

(1) Operating condition

Ambient temperature: $-10^{\circ}\text{C} \sim +45^{\circ}\text{C}$
Relative humidity: $\leq 85\%$

(2) Storage condition

Ambient temperature: $-20^{\circ}\text{C} \sim +60^{\circ}\text{C}$
Relative humidity: $45\% \sim 75\%$

Reliability Test

1) Vibration Test

To be no interference in operation after vibration of full amplitude 2mm for 30 minutes at three axis, the sensitivity to be within $\pm 3\text{dB}$ from initial sensitivity.

2) Drop Test

To be no interference in operation after dropped to concrete floor each time from 1 meter height of three directions in state of packing, the sensitivity to be within $\pm 3\text{dB}$ from initial sensitivity.

3) High Temperature Test

To be no interference in operation after high temperature test $70 \pm 3^{\circ}\text{C}$ for 48 hours, the sensitivity to be within $\pm 3\text{dB}$ from initial sensitivity.

4) Isotherm & Iso-humidity Test

To be no interference in operation after storage test at temperature $60 \pm 2^{\circ}\text{C}$ and relative humidity $(93 \pm 3\%)$ for 48 hours, the sensitivity to be within $\pm 3\text{dB}$ from initial sensitivity, the test is performed at temperature 20°C after operation for 6 hours.

5) Low Temperature Test

To be no interference in operation after high temperature test $-20 \pm 3^{\circ}\text{C}$ for 48 hours, the sensitivity to be within $\pm 3\text{dB}$ from initial sensitivity.

6) Temperature Cycle Test

After exposure at $+55 \pm 2^{\circ}\text{C}$ for 1 hour, at $20 \pm 2^{\circ}\text{C}$ for 1 hour, at $-10 \pm 2^{\circ}\text{C}$ for 1 hour, at $20 \pm 2^{\circ}\text{C}$ for 1 hour, with 5 cycles. Change of sensitivity within $\pm 3\text{dB}$ from initial measuring should be done after 2 hours exposed to $20 \pm 2^{\circ}\text{C}$.

7) Collision Test

After collided with the acceleration $100 \pm 10\text{m/s}$, at the vertical & horizontal directions for 1000 ± 10 times, at the state of packing. Change of sensitivity within $\pm 3\text{dB}$ from initial.

TEST RESULT OF SAMPLES

NO.	1KHz (dB)	CURRENT (mA)	NOTES
1	-49	0.17	(1KHz、0dB=1V/Pa)
2	-50	0.17	
3	-50	0.16	
4	-50	0.15	
5	-50	0.18	
6	-49.9	0.2	
7	-50.6	0.22	
8	-50.4	0.15	
9	-49.6	0.17	
10	-49.7	0.17	
11	50.3	0.15	
12	-50	0.16	
13	-51.1	0.16	
14	-51.1	0.16	
15	-49	0.17	

Customer: **Digi-Key Corporation**

Date: 2004.02.04

Part number: EM4513-50BC10&33

Sensitivity: -50±4dB

Test condition: 2.2K Ω 2V

Tester: G1



深圳市豪恩电声科技有限公司

SHENZHEN HORN ELECTROACOUSTIC TECHNOLOGY CO., LTD
 TEL: 86-755-28121370/28121371/28109416/28109419
 FAX: 86-755-28109417
 Website: www.horn.com.cn
 E-mail: rd@horn.com.cn

Certificate of Confirmed Products

Date: Feb. 04. 2004

NO: W04011401

SUPPLIER	HORN	BUYER	Digi-Key Corporation	
TITLE	ECM	MODEL	EM4513-50BC10&33	
SIZE	φ 4.5 × 1.3mm	TEST CONDITION	2.2K Ω 2V	
QUANTITY		SAMPLE: 15PCS		
SPECIFICATIONS				
Sensitivity		-50 ± 4dB (0dB=1V/Pa. 1KHz)		
Directivity		Omnidirectional		
Impedance		Low impedance		
Standard operation voltage		2V		
Operation voltage		1.0-10V		
Current consumption		Max500uA		
Maximum input S.P.L		100dB		
S/N ratio		More than 58dB		
Sensitive reduction		within-3dB at 1.5V		
The test result from customers		Signature: _____ . _____ . 2004		
Final confirmed	Pass	Refuse	Accepted basis on	
Remarks				

***** The form must be confirmed by return fax after your test as your best regards! *****