



iNAV[®] 31K G2 AdvancedMC[™] Carrier Card

Flexible, high-performance building block for ATCA 3.1 systems

FEATURES

Flexible and Intelligent AdvancedMC carrier

Supports four Mid-size Advanced MCs with option to support up to two Mid-size Double-Width AMCs

Supports 1 and 10 Gigabit Ethernet (ATCA 3.1 Options 1, 9) ATCA Fabric, as well as Gigabit Ethernet Base Interface links

Advanced fully manageable Ethernet Switching technology

AMC.1: Optional x4 PCI Express links to each AdvancedMC bay, with support for a Processor AMC.

AMC.2: Four Gigabit Ethernet links to each AdvancedMC bay

AMC.3: Support for SAS / SATA disk AdvancedMCs.

Powerful Linux[®]-based Board Management Computer

Advanced Telecom Clock management provides the ability to accept a synchronization clock from any AdvancedMC bay and to drive a clock to any combination of AdvancedMC bays.

APPLICATIONS

Gateway GPRS Support Nodes (GGSNs)

HLRs

Softswitches

Routers

Media Gateways

Wireless Base Station

Audio and Video Service Platform

Serving GPRS Support Nodes (SGSNs)

Next Generation Networks

The next-generation network has the potential to seamlessly blend the public switched telephone network with both public and private data networks into a single multiservice network. In response, service providers are aggressively deploying a new generation of cost-effective, open systems architectures that promise to transform the telecommunications market in the same way that personal computers changed enterprise networking. But to compete and win in this competitive environment, carriers must offer revenue-generating enhanced services ahead of the competition, reduce up-front costs, preserve investments in existing infrastructure, future-proof new deployments, and provide a high degree of scalability.

Intelligent, Flexible, and High Performance with 10G Fabric Support

The iNAV 31K G2 AdvancedMC Carrier Card is a flexible, high-performance addition to next-generation systems. It meets the needs of a wide variety of applications in ATCA 3.1 systems, including I/O, processing, and storage.

The iNAV 31K G2 features include a high-performance Ethernet switch with 24 gigabit ports and up to two 10 gigabit ports, an optional PCI Express switch, advanced Telecom Clock management, and a Linux[®]-based Board Management Processor that provides full local and remote management.

10/20/2009



iNAV 31K G2 Features

Hardware

- AdvancedMC Bays
 - Bay B4 can support a Processor AdvancedMC which may act as root for the optional PCI Express interconnect
 - Bay B4 can also control SAS/SATA disk AdvancedMCs installed in Bays B1 and/or B2 (AMC.3 Type S1):
 - Port 2 of Bay B1 is connected to Port 2 of Bay B4
 - Port 2 of Bay B2 is connected to Port 3 of Bay B4
- Ethernet Switch
 - Four Gigabit Ethernet links are provided for each AdvancedMC bay on ports 0, 1, 8, 9 (AMC.2 Type 2E2)
 - Two links for the Base Interface
 - Links for the Board Management Computer, and the optional RTM
 - The ATCA 3.1 Fabric Interface supports one pair of 1 Gigabit or 10 Gigabit (XAUI) links compliant with ATCA 3.1 Options 1 and 9 to the ATCA 3.1 fabric
 - Line-rate switching under all conditions, IPv6 support, full VLAN support, advanced QoS, link aggregation, port mirroring, and many other advanced features
- Board Management Computer (BMC)
 - Power Architecture™ 8347E at 667 MHz
 - Up to 1 GB DDR RAM (SODIMM)
 - Gigabit connection to the Ethernet switch
 - Partitioned boot flash supports in-service field update
- Telecom Clock Management
 - On-board Telecom Clock management circuit provides the ability to accept a synchronization clock from any AdvancedMC bay or the backplane, and to drive a clock to any combination of AdvancedMC bays. Full management is provided through the BMC
- IPM Controller
 - Fully compliant with relevant ATCA 3.0, ATCA 3.1, and AdvancedMC specifications.
 - Based on the industry-standard Pigeon Point IPM Sentry products
- Optional PCI Express Interconnect
 - PCI Express switch provides x4 PCI Express connectivity to each AdvancedMC bay on ports 4-7 (AMC.1 Type 4), the RTM, and the Board Management Computer.
 - Location of the root complex is configurable to be either the BMC or AdvancedMC Bay B4
- Optional Rear Transition Module Support
 - AdvancedMC Ports 13-15, 17-20 from AdvancedMC bays B1 through B4 are routed to the connector
 - An optional x4 PCI Express link is provided for RTM management, along with Telecom Clock I/O and IPM Controller connections
- Port 12 of each AdvancedMC optionally routed to ATCA Update Channels

Software

The iNAV 31K G2 includes a rich suite of software for the Board Management Computer, as well as a fully-featured firmware package for the IPM Controller. The Board Management Computer (BMC) requires no further customer-provided programming, but it is also available for customer-provided application programs if desired. In some applications, the added cost of a Processor AdvancedMC or external processor blade may be avoided by running customer application software directly on the BMC.

- Boot monitor with Power-On Self Test and support for in-service firmware update with fallback.
- Wind River PNE Linux with driver support for all on-board hardware.
- Local Flash File System, and full IP services including DHCP and FTP.
- Configuration and management of the on-board Telecom Clock Management circuits, including input source select, output control, and failover behavior.
- Communication APIs for easy integration with the IPM Controller. Support for Hot Swap notification, Bused Resource messages, thermal measurements, inventory data, and AdvancedMC presence and power control.
- Adequate processor resources are available for complex customer-provided software.
- Advanced fully manageable Ethernet Switching technology Switch Management Software toolkits are available to provide management for the extensive capabilities of the on-board Ethernet Switch. Capabilities include:
 - Advanced traffic management features including DiffServ, Access Control Lists and Bandwidth Provisioning
 - Powerful and flexible configuration and management interfaces, including Command Line Interface and SNMP. Configuration and management of all major on-board hardware is provided through this common interface.
 - Rich Layer 2 feature set, including 802.1D Spanning Tree, 802.1Q port and protocol based VLANs, and 802.3ad Link Aggregation. Additional features include 802.1p Class of Service support, 802.3x Flow Control and advanced Layer 2 functionality such as 802.1s Multiple Spanning Trees and 802.1W Rapid Spanning Tree. Also port mirroring functionality, multicast provided by IGMP snooping, and advanced security features. In addition to the standard driver-level interface, advanced high-end switch management software is available. This software provides fully-featured switch management, including a full GUI interface.
 - Layer 3 routing including RIP v1/v2, OSPFv2, and wire-speed routing.

Contact Interphase for assistance with development of these capabilities.



iNAV 31K G2 Hardware

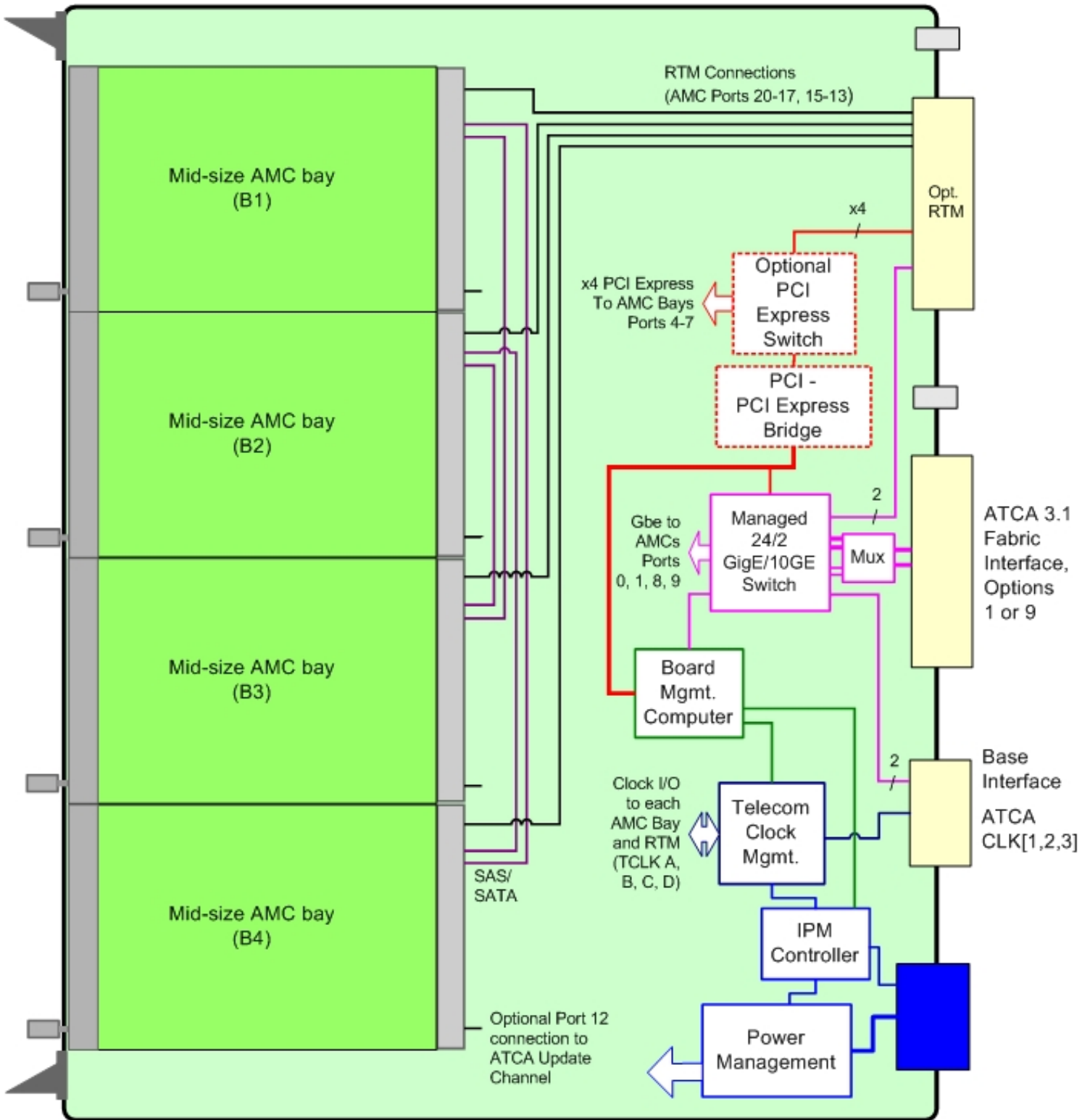



iNAV 31K G2 AdvancedMC Carrier Card

Configuration Options

The iNAV 31K G2 AdvancedMC Carrier Card can be configured with the following options:

- **Processor RAM Memory:** up to 1GB
- **PCI-e Switch:** PEX 8524
Provides support for AMC.1 AdvancedMC's with connectivity to the Blade Processor.
- **Managed Ethernet Switch:** BCM 56502
Upgrade to the BCM 56502 provides increased performance of the Ethernet Switch. The BCM 56502 provides larger buffers, better traffic capacity and improved queuing support. The choice of switch is transparent to the switch management interfaces.
- **NAND Flash:** up to 512 MB
- **Optional Rear Transition Module Support:**
Interphase will develop Rear Transition Modules (RTMs) to support customer-specified configurations of AdvancedMCs in Bays B1, B2, B3, and B4 of the iNAV 31K-G2 AdvancedMC Carrier Card. Custom RTMs may support AdvancedMCs provided by Interphase or by other vendors. Please contact Interphase for more information.

Custom Development

Custom software development, integration, and consulting services are also available via the Interphase Professional Services Group. With over 150 man years of development experienced amassed, the professional services team offers everything from completely custom development to merely customizing standard Interphase products to meet your specific needs.



Technical Specifications

Managed Ethernet Switch

BCM 56302	1 Gigabit ATCA 3.1 Option 1 Fabric Interface
	10 Gigabit ATCA 3.1 Option 9 Fabric Interface

Board Management Computer

Processor	Power Architecture™ 8347E at 667 MHz
RAM Memory	512MB SODIMM
ROM Memory	16MB NOR flash (two 8 MB partitions for in-service field update) 256MB NAND flash file system (expandable)

Mechanical

Form Factor	ATCA Mid-size Carrier AdvancedMC Bays B1, B2, B3, B4
Length	322.25 mm
Width	280 mm

Operating Environment

Power Distribution Limits	43W @ 12V no module power included 25W @ 12V for the RTM 173W for AMC and RTM 251W for blade with maximum load
Temperature	0 to 55 °C (32 to 131 °F)
Storage Range	-40 to 80 °C (-40 to 176 °F)
Relative Humidity	5% to 95% non-condensing
Altitude	0 to 2000 M (0 to 6500 ft)

Corporate Headquarters

Parkway Centre 1
2901 N. Dallas Parkway
Plano, Texas 75093
1-800-FASTNET
Phone: + 1.214.654.5000
Fax: + 1.214.654.5500

European Headquarters

Centre d'affaires 10ème
Avenue
855, avenue Roger Salengro
92370 Chaville - France
Tél.: + 33 (0) 1 41 15 44 00
Fax: + 33 (0) 1 41 15 12 13

Asia/Pacific Headquarters

27 Brallas Avenue
St. Ives NSW 2075
Australia
Tel.: + 612 9440 2140
Fax: + 612 9440 2141

About Interphase Corporation

Interphase Corporation (NASDAQ: INPH) delivers solutions for network connectivity, interworking, and packet processing for key applications for the communications, Mil/Aero, and enterprise markets. Founded in 1974, Interphase provides expert customization services and contract manufacturing, in addition to its COTS portfolio, and plays a leadership role in next generation AdvancedTCA® (ATCA), AdvancedMC™ (AMC),