



## TS-5112

### 12.1" TFT LCD Touchscreen User Interface

The TS-5112 is a high quality 12.1-inch TFT LCD touchscreen that supports display of Panelmaker® software items with Berkeley's Series-32, Series-64 and BX-series controller products. It is provided with Microsoft Windows® CE.NET operating system installed. The TS-5112 is a drop-in replacement for certain applications using the 3M 3170, Fluke/Dynapro 1020, 1030 and 1050 touchscreen models.

## FEATURES

- 12.1" SVGA TFT LCD with high luminance
- Slim and compact design with Al-Mg housing
- Fanless cooling system
- NEMA4/IP65 compliant front panel
- Windows CE.NET Operating System
- 16mb CompactFlash™ storage (upgradable to 256mb)
- 4 serial ports, 1 Ethernet port (10/100Mbps), 2 PS/2 ports
- Optional TS-3000-C and TS-3200-FP retrofit kits
- Optional MachineWorks Server for CE.NET



# SPECIFICATIONS

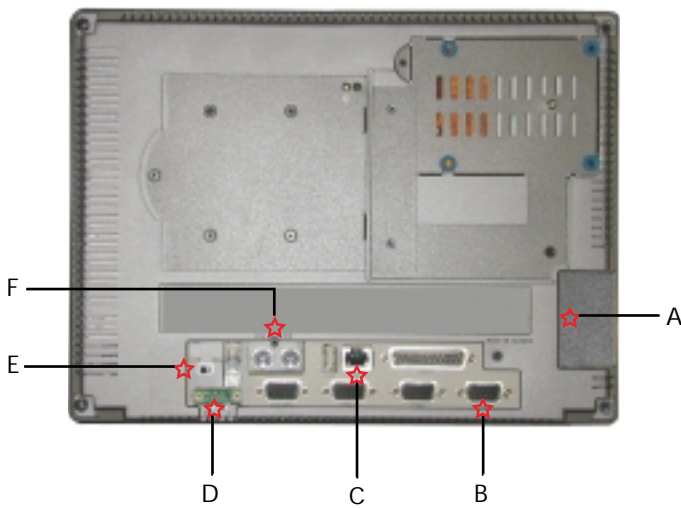
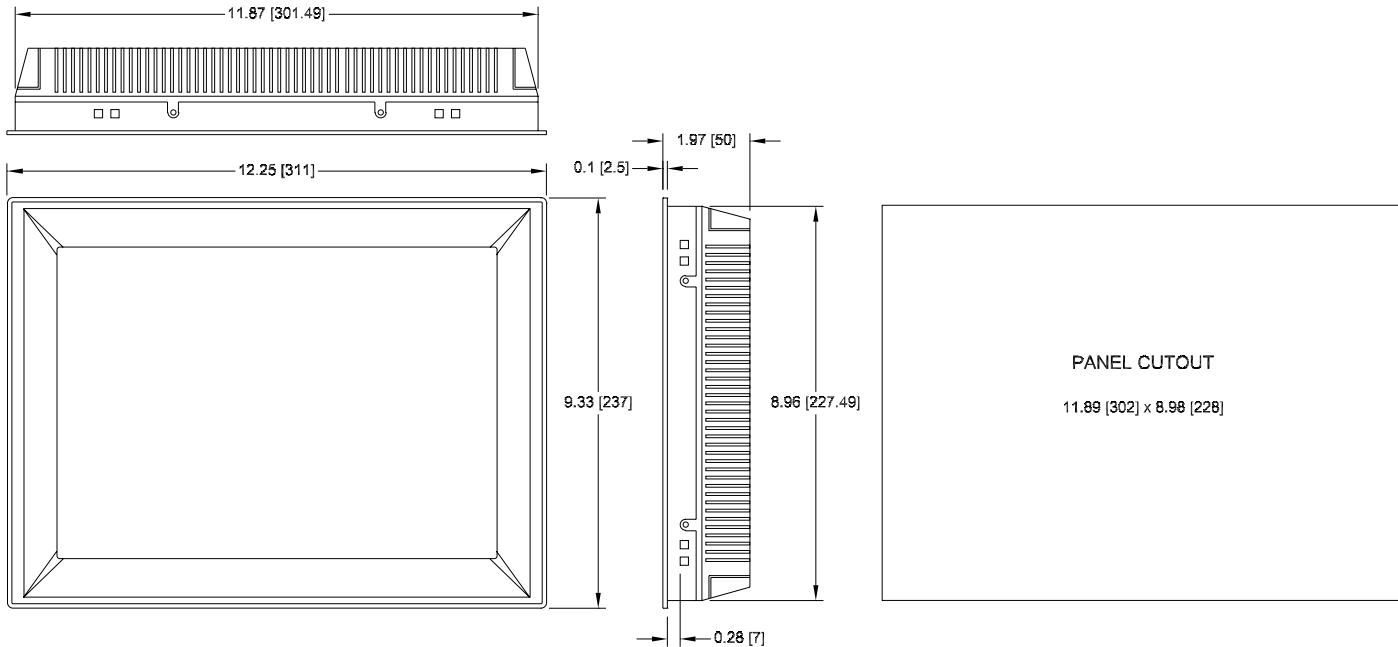

- A. CompactFlash
- B. Serial ports (4)
- C. Ethernet port
- D. Power connector
- E. Power switch
- F. PS/2 ports

Display Type	TFT Color LCD
Display Size (diag)	12.1"
Max Colors	256K
Resolution	800 x 600
Pixel Pitch (HxV, MM)	0.31 x 0.31
Viewing angle (°)	90
Luminance (cd/m2)	100
Storage temperature (°C)	-20 ~ 60 (-4° ~ 140°F)
Oper. temperature (°C)	0 ~ 50 (32° ~ 122°F)
Backlight	1 CCFL
Contrast Ratio	150
Weight	4.85 lbs. (2.2kg)
Power Input	24VDC, 0.8A Max.
Dimensions	12.25" x 9.35" x 2.00"



Corporate/USA Headquarters  
4124 Lakeside Drive  
Richmond, CA 94806  
tel 510.222.8004  
fax 510.222.8737  
www.berkeleyprocess.com  
e-mail marketing@berkeleyprocess.com

European Headquarters  
tel +44 (0)7041 390 070  
e-mail info.eu@berkeleyprocess.com

The products described herein, including without limitation, product features, specifications, designs and availability are subject to change without notice. Windows® is a trademark of Microsoft Corporation. CompactFlash® is a registered trademark of SanDisk Corporation.