

## Terminal Block Dual Output Signal Conditioners W5-UNIT

### RTD TRANSMITTER

#### Functions & Features

- Accepts direct input from a RTD
- Two independent output ranges
- Four-way isolation (input to output 1 to output 2 to power)
- Linearization and burnout
- Fast response type available
- High-density mounting
- CE marking for 24 V power

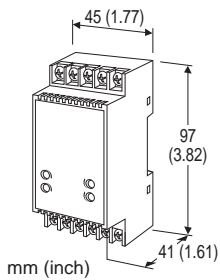

### MODEL: W5RS-[1][2][3]-[4][5]

#### ORDERING INFORMATION

Specify a code from below for each [1] through [5].

When only one output is needed, select code Y for Output 2, [3].

- Code number: W5RS-[1][2][3]-[4][5]  
(e.g. W5RS-4A6-R/K/BL/Q)

Specify variables.

- Temperature range (e.g. 0 - 500°C)
- Special output range (For codes Z & 0)
- Specify the specification for option code /Q  
(e.g. /C01/V01)

#### [1] INPUT RTD (2- or 3-wire)

**1:** JPt 100 (JIS'89)

(Usable range: -200 to +500°C, -328 to +932°F; min.span: 50°C, 90°F)

**3:** Pt 100 (JIS'89)

(Usable range: -200 to +650°C, -328 to +1202°F; min.span: 50°C, 90°F)

**4:** Pt 100 (JIS'97, IEC)

(Usable range: -200 to +850°C, -328 to +1562°F; min.span: 50°C, 90°F)

**5:** Pt 50 Ω (JIS'81)

(Usable range: -200 to +500°C, -328 to +932°F; min.span: 100°C, 180°F)

**6:** Ni 508.4 Ω

(Usable range: -50 to +200°C, -58 to +392°F; min.span: 30°C, 54°F)

**0:** Specify

#### [2] OUTPUT 1

##### Current

**A:** 4 - 20 mA DC (Load resistance 550 Ω max.)

**B:** 2 - 10 mA DC (Load resistance 1100 Ω max.)

**C:** 1 - 5 mA DC (Load resistance 2200 Ω max.)

**D:** 0 - 20 mA DC (Load resistance 550 Ω max.)

**E:** 0 - 16 mA DC (Load resistance 685 Ω max.)

**F:** 0 - 10 mA DC (Load resistance 1100 Ω max.)

**G:** 0 - 1 mA DC (Load resistance 11 kΩ max.)

**Z:** Specify current (See OUTPUT SPECIFICATIONS)

##### Voltage

**1:** 0 - 10 mV DC (Load resistance 10 kΩ min.)

**2:** 0 - 100 mV DC (Load resistance 100 kΩ min.)

**3:** 0 - 1 V DC (Load resistance 100 Ω min.)

**4:** 0 - 10 V DC (Load resistance 1000 Ω min.)

**5:** 0 - 5 V DC (Load resistance 500 Ω min.)

**6:** 1 - 5 V DC (Load resistance 500 Ω min.)

**4W:** -10 - +10 V DC (Load resistance 2000 Ω min.)

**5W:** -5 - +5 V DC (Load resistance 1000 Ω min.)

**0:** Specify voltage (See OUTPUT SPECIFICATIONS)

#### [3] OUTPUT 2

Same range availability as Output 1

**Y:** None

#### [4] POWER INPUT

##### AC Power

**M:** 85 - 264 V AC (Operational voltage range 85 - 264 V, 47 - 66 Hz)

(CE not available)

##### DC Power

**R:** 24 V DC

(Operational voltage range 24 V ±10 %, ripple 10 %p-p max.)

**R2:** 11 - 27 V DC

(Operational voltage range 11 - 27 V, ripple 10 %p-p max.)

(CE not available)

**P:** 110 V DC

(Operational voltage range 85 - 150 V, ripple 10 %p-p max.)

(CE not available)

#### [5] OPTIONS (multiple selections)

##### Response Time (0 - 90 %)

**blank:** Standard (≤ 0.5 sec.)

**/K:** Fast Response (Approx. 25 msec.)

##### Burnout

**blank:** Upscale burnout

**/BL:** Downscale burnout

##### Other Options

**blank:** none

**/Q:** Option other than the above (specify the specification)

## SPECIFICATIONS OF OPTION: Q (multiple selections)

### COATING (For the detail, refer to M-System's web site.)

/C01: Silicone coating

/C02: Polyurethane coating

/C03: Rubber coating

### ADJUSTMENT

/V01: Multi-turn fine adjustment

/VN: Sealed adjustment holes

## GENERAL SPECIFICATIONS

**Construction:** Terminal block

### Connection

**Input:** M3.5 screw terminals (torque 0.8 N·m)

**Output & power:** M3 screw terminals (torque 0.8 N·m)

**Screw terminal:** Nickel-plated steel

**Housing material:** Flame-resistant resin (black)

**Isolation:** Input to output 1 to output 2 to power

**Overrange output:** Approx. -10 to +120 % at 1 - 5 V

**Zero adjustment:** -2 to +2 % (front)

**Span adjustment:** 98 to 102 % (front)

**Linearization:** Standard

## INPUT SPECIFICATIONS

**Input:** 2- or 3-wire RTDs

**Maximum leadwire resistance:** 200 Ω per wire (3-wire)

**Sensing current:** 2 mA (Pt); 1 mA (Ni 508.4 Ω)

## OUTPUT SPECIFICATIONS

■ **DC Current:** 0 - 20 mA DC

**Minimum span:** 1 mA

**Offset:** Max. 1.5 times span

**Load resistance:** Output drive 11 V max.

■ **DC Voltage:** -10 - +12 V DC

**Spans:** Min. 5 mV, max. 20 V

**Offset:** Max. 1.5 times span

**Load resistance:** Output drive 10 mA max.; 5 mA for negative voltage output; at  $\geq 0.5$  V

## INSTALLATION

### Power Consumption

#### •AC:

Approx. 4 VA at 100 V

Approx. 5 VA at 200 V

Approx. 6 VA at 264 V

#### •DC: Approx. 3 W

**Operating temperature:** -5 to +55°C (23 to 131°F)

**Operating humidity:** 0 to 90 %RH (non-condensing)

**Mounting:** DIN rail

**Weight:** 130 g (0.29 lbs)

## PERFORMANCE in percentage of span

**Accuracy:**  $\pm 0.2$  %

**Temp. coefficient:**  $\pm 0.015\%/^{\circ}\text{C}$  ( $\pm 0.008\%/^{\circ}\text{F}$ )  
(at over 200°C or 360°F spans)

**Burnout response:**  $\leq 10$  sec.

**Line voltage effect:**  $\pm 0.1$  % over voltage range

**Insulation resistance:**  $\geq 100$  MΩ with 500 V DC

### Dielectric strength:

2000 V AC @1 minute (input to output 1 or output 2 to power to ground)

1000 V AC @1 minute (output 1 to output 2)

## STANDARDS & APPROVALS

### CE conformity:

EMC Directive (2004/108/EC)

EMI EN 61000-6-4: 2007

EMS EN 61000-6-2: 2005

## DIMENSIONS unit: mm (inch)

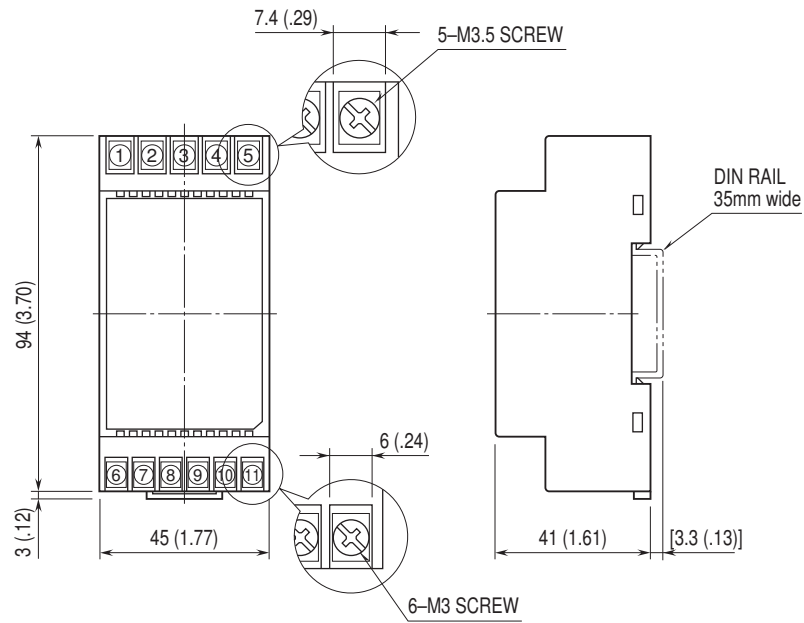

• When mounting, no extra space is needed between units.

## SCHEMATIC CIRCUITRY & CONNECTION DIAGRAM

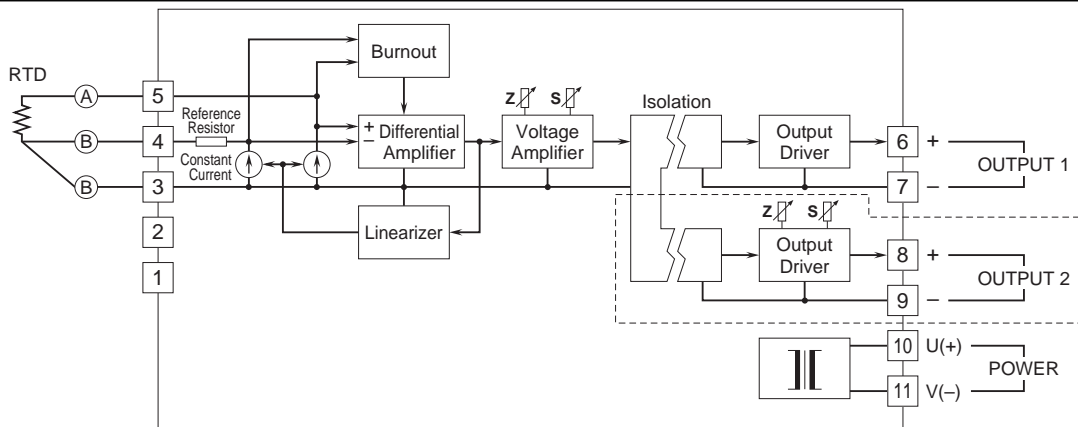

Remark 1: The section enclosed by broken line is only with 2nd output option.  
 Remark 2: DO NOT connect to the terminals 1 – 2.



Specifications are subject to change without notice.