

## Tension-Clamp Ultra-Slim Signal Conditioners M6S Series

### 2-INPUT MATH FUNCTION MODULE

(PC programmable)

#### Functions & Features

- Maintenance-free tension clamp connection
- 5.9-mm wide ultra-slim design
- Low profile allows the M6S module mounted in a 120-mm deep panel
- 2-input math functions and signal selector functions
- PC programmable
- High-density mounting
- Power indicator LED

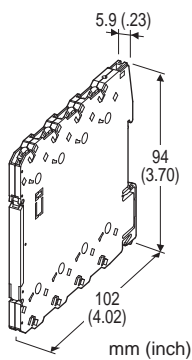

### MODEL: M6SXF2-[1][2][3]-R

#### ORDERING INFORMATION

- Code number: M6SXF2-[1][2][3]-R  
Specify a code from below for each [1] through [3].  
(e.g. M6SXF2-S2Z1Z1-R)
- Input 1 range (e.g. 1 - 5 V DC)
- Input 2 range (e.g. 4 - 20 mA DC)
- Output range (e.g. 4 - 20 mA DC)

#### [1] INPUT 1

##### Current

**Z1:** Range 0 - 50 mA DC (Input resistance 24.9 Ω)

##### Voltage

**S1:** Range -1000 - +1000 mV DC (Input resistance 1 MΩ min.)

**S2:** Range -10 - +10 V DC (Input resistance 1 MΩ min.)

(Configurator software is used to change the input type and precise range.)

#### [2] INPUT 2

Same range availability as Input 1

(Configurator software is used to change the input type and precise range.)

#### [3] OUTPUT

##### Current

**Z1:** Range 0 - 20 mA DC

##### Voltage

**V2:** Range -10 - +10 V DC

**V3:** Range -5 - +5 V DC

(Configurator software is used to change the output type and precise range.)

#### POWER INPUT

##### DC Power

**R:** 24 V DC

(Operational voltage range 24 V ±10 %, ripple 10 %p-p max.)

#### FUNCTIONS

PC Configurator Software is used to change function type.

##### Math Functions:

- Temperature compensation (w/o square root extraction)
- Temperature compensation (with square root extraction)
- Pressure compensation (w/o square root extraction)
- Pressure compensation (with square root extraction)
- Addition / Subtraction
- Multiplication
- Division

##### Signal Selector Functions:

- High selector
- Low selector

#### RELATED PRODUCTS

- PC configurator software (model: M6CFG)  
Downloadable at M-System's web site.  
A dedicated cable is required to connect the module to the PC. Please refer to the internet software download site or the users manual for the PC configurator for applicable cable types.

#### GENERAL SPECIFICATIONS

##### Connection

**Input and output:** Tension clamp

**Power input:** Via the Installation Base (model: M6SBS) or Tension clamp

**Applicable wire size:** 0.2 to 2.5 mm<sup>2</sup>, stripped length 8 mm

**Housing material:** Flame-resistant resin (black)

**Isolation:** Input 1 or input 2 to output to power  
No isolation between the inputs. Maintain the same potential level at both inputs.

**Overrange output:** -2 - +102 %

(Negative current output is not available.)

**Zero adjustment:** -2 to +2% (PC programming)

**Span adjustment:** 98 to 102% (PC programming)

**Power LED:** Green light turns on when the power is supplied.

**Status indicator LED:** Orange LED; Flashing patterns indicate different operating status of the transmitter.

**Programming:** Downloaded from PC; input type and range, output type and range, zero and span, function type and parameters, etc.

For detailed information, refer to the users manual for the PC configurator.

**Configurator connection:** 2.5 dia. miniature jack; RS-232C level

## INPUT SPECIFICATIONS

• **DC Current:** Input resistor incorporated  
(If not specified, the input range is 4 - 20 mA DC.)

**Input range:** 0 - 50 mA DC

**Minimum span:** 2 mA

**Offset:** Lower range can be any specific value within the input range provided that the minimum span is maintained.

• **DC Voltage**

**Code S1 (narrow spans)**

**Input range:** -1000 - +1000 mV DC

**Minimum span:** 100 mV

**Code S2 (wide spans)**

**Input range:** -10 - +10 V DC

**Minimum span:** 1 V

**Offset:** Lower range can be any specific value within the input range provided that the minimum span is maintained.

If not specified, the input range is shown below.

S1: 0 - 100 mV DC

S2: 1 - 5 V DC

## OUTPUT SPECIFICATIONS

• **DC CURRENT**

**Output range:** 0 - 20 mA DC

**Conformance range:** 0 - 20.4 mA DC

**Minimum span:** 1 mA

**Offset:** Lower range can be any specific value within the output range provided that the minimum span is maintained.

**Load resistance:** Output drive 11 V max.

(e.g. 4 - 20 mA: 550 Ω [11 V/20 mA])

If not specified, the output range is 4 - 20 mA DC.

• **DC VOLTAGE**

**Code V2 (wide spans)**

**Output range:** -10 - +10 V DC

**Conformance range:** -10.4 - +10.4 V DC

**Minimum span:** 1 V

**Code V3 (narrow spans)**

**Output range:** -5 - +5 V DC

**Conformance range:** -5.2 - +5.2 V DC

**Minimum span:** 0.5 V

**Offset:** Lower range can be any specific value within the output range provided that the minimum span is maintained.

**Load resistance:** Output drive 1 mA max.

(e.g. 1 - 5 V: 5000 Ω [5 V/1 mA])

If not specified, the output range is shown below.

V2: 0 - 10 V DC

V3: 1 - 5 V DC

## INSTALLATION

**Power consumption:** Approx. 0.5 W

**Operating temperature:** -20 to +55°C (-4 to +131°F)

**Operating humidity:** 30 to 90 %RH (non-condensing)

**Mounting:** Installation Base (model: M6SBS) or DIN rail

**Weight:** 65 g (2.3 oz)

## PERFORMANCE in percentage of span

**Overall accuracy:** Input accuracy + output accuracy  
See CALCULATION EXAMPLES OF OVERALL ACCURACY

• **Input accuracy\*:** (% of max. input range)

-1000 - +1000 mV : ±0.05 %

-10 - +10 V : ±0.05 %

0 - 50 mA : ±0.1 %

• **Output accuracy\*\*:** ±0.04% of max. output range

\*Inversely proportional to the span.

For math functions, the input accuracy equals that of either input 1 or 2, whichever is greater, with the following parameter setting:

$K_1=K_2=1$ ,  $A_2=0\%$ ,  $X_2=100\%$  for temp./press. compensation

$K_0=0.5$ ,  $K_1=K_2=1$ ,  $A_0=A_1=A_2=0\%$  for four arithmetic functions

For selector functions, it equals that of the selected signal.

\*\*Inversely proportional to the span.

**Temp. coefficient:** ±0.01 %/°C (±0.006 %/°F) of max. span

**Response time:** ≤ 0.5 sec. (0 - 90 %)

**Line voltage effect:** ±0.1 % over voltage range

**Insulation resistance:** ≥ 100 MΩ with 500 V DC

**Dielectric strength:** 2000 V AC @1 minute (input to output to power to ground)

## CALCULATION EXAMPLES OF OVERALL ACCURACY

[Example] Function: Temperature compensation w/o square root extraction;  $K_1=K_2=1$ ,  $A_2=0\%$ ,  $X_2=100\%$

Input 1: Type -10 - +10 V / range 1 - 5 V

Input 2: Type 0 - 50 mA / range 4 - 20 mA

Output: Type 0 - 20 mA / range 4 - 20 mA

Input 1 = Max. Input Range (20 V) / Span (4 V) × 0.05% = 0.25%

Input 2 = Max. Input Range (50 mA) / Span (16 mA) × 0.1% = 0.31%

Output = Max. Output Range (20 mA) / Span (16 mA) ×

0.04% = 0.05%

Accuracy = 0.31% (input 2 > input 1) + 0.05% = 0.36%

## STANDARDS & APPROVALS

CE conformity:

EMC Directive (2004/108/EC)

EN 61000-6-4 (EMI)

EN 61000-6-2 (EMS)

## EXTERNAL VIEW

■ FRONT VIEW (with the cover open)

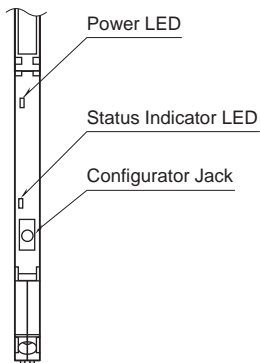

■ SIDE VIEW

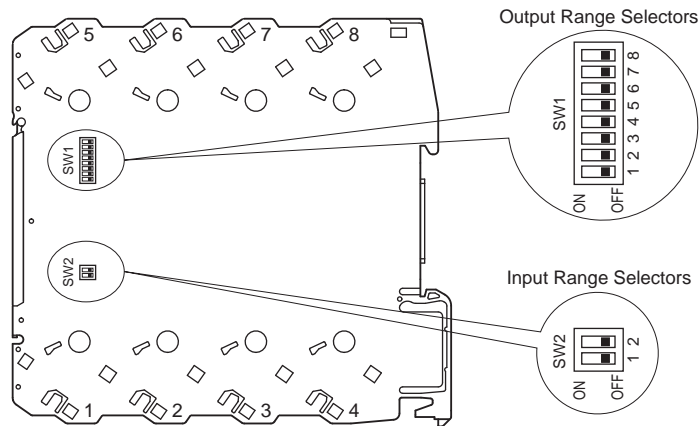

The DIP switch setting is required to select input and output types before setting a precise range using PC Configurator Software (model: M6CFG).

Refer to the instruction manual for detailed procedures.

## DIMENSIONS unit: mm (inch)

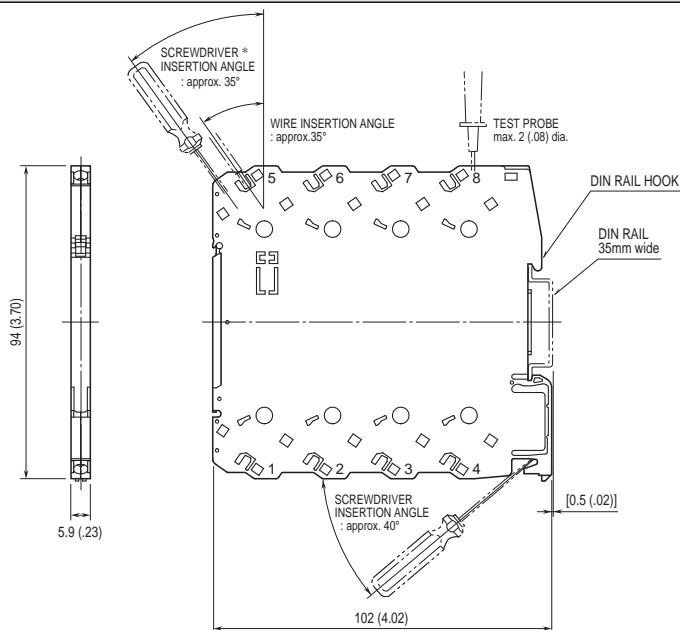

\* When mounting, no extra space is needed between units.

\*Use a minus screwdriver: tip width 3.8 mm max., tip thickness 0.5 to 0.6 mm

**SCHEMATIC CIRCUITRY & CONNECTION DIAGRAM**

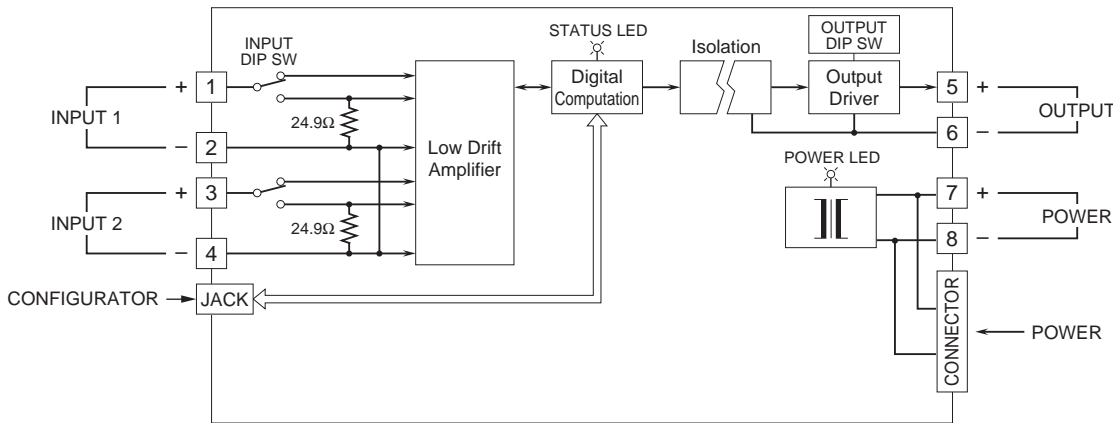

**FUNCTIONS**

■ FUNCTIONS

• Math Functions

Temperature compensation (w/o square root extraction)

$$X_0 = \frac{K_1 X_1}{\sqrt{K_2 X_2 + A_2}}$$

where  $X_0$  : Compensated flow (linear characteristics)  
 $X_1$  : Uncompensated flow  
 $X_2$  : Temperature

Temperature compensation (with square root extraction)

$$X_0 = \frac{K_1 \sqrt{X_1}}{\sqrt{K_2 X_2 + A_2}}$$

where  $X_0$  : Compensated flow (linear characteristics)  
 $X_1$  : Uncompensated flow  
 $X_2$  : Temperature

Pressure compensation (w/o square root extraction)

$$X_0 = K_1 X_1 \sqrt{K_2 X_2 + A_2}$$

where  $X_0$  : Compensated flow (linear characteristics)  
 $X_1$  : Uncompensated flow  
 $X_2$  : Pressure

Pressure compensation (with square root extraction)

$$X_0 = K_1 \sqrt{X_1} \sqrt{K_2 X_2 + A_2}$$

where  $X_0$  : Compensated flow (linear characteristics)  
 $X_1$  : Uncompensated flow  
 $X_2$  : Pressure

Addition / Subtraction

$$X_0 = K_0 \{K_1 (X_1 + A_1) + K_2 (X_2 + A_2)\} + A_0$$

Multiplication

$$X_0 = K_0 (K_1 X_1 + A_1) (K_2 X_2 + A_2) + A_0$$

Division

$$X_0 = \frac{K_0 (K_1 X_1 + A_1)}{(K_2 X_2 + A_2)} + A_0$$

• Signal Selector Functions

High selector

$$X_0 = X_1 \text{ with } X_1 \geq X_2$$

$$X_0 = X_2 \text{ with } X_1 < X_2$$

Low selector

$$X_0 = X_2 \text{ with } X_1 \geq X_2$$

$$X_0 = X_1 \text{ with } X_1 < X_2$$

Available range

$X_0$  : Output (%) -2 to +102%

$X_1$  through  $X_2$  : Input (%) -2 to +102%

$K_0$  through  $K_2$  : Gain (no unit)  $\pm 29.999$

$A_0$  through  $A_2$  : Bias (%)  $\pm 299.99\%$

Factory default setting: Addition / Subtraction

$K_0 = 1, K_1 = 1, K_2 = 1, A_0 = 0\%, A_1 = 0\%, A_2 = 0\%$



Specifications are subject to change without notice.