

LINCOLN

®

CENTRO-MATIC® AUTOMATED LUBRICATION SYSTEMS



"I install Lincoln Centro-Matic systems with confidence because I know they're going to prolong the life of my customer's critical machinery."

**Les Maness, Installation Foreman,
Lincoln Distributor**

People, Capabilities and Systems to Save Money and Increase Productivity



We're the largest and most successful company in our field because we continually satisfy our customers with the world's best lubrication and pumping systems. For almost 90 years, companies have relied on our technical and quality leadership, our world-class manufacturing and customer service, and our vast network of distributors and support facilities.

Lincoln develops new products and systems at research and development facilities in the U.S., Germany and India that provide global and regional application solutions.

We have solutions for large processing plants, automotive manufacturing, pulp and paper mills, and food and beverage facilities. Virtually every industrial professional involved in operations and maintenance can benefit from Lincoln systems.

On the road or in the field, Lincoln protects heavy equipment used in mining, construction, agriculture and over-the-road trucking. The world's leading manufacturers offer our systems as standard equipment or factory options.

Lincoln builds precision metal components, state-of-the-art electronic controls, and the industry's top-performing pump systems. Our quality systems in the United States and Germany are ISO 9001 registered.

With five technical support centers on three continents, and a network of systems houses and distributors supported by regional sales and service offices, our customers can always draw on our worldwide resources.

To make sure your investment results in significant savings, Lincoln developed a unique program called BearingSaver®. You not only get a complete audit of your facility, you also receive an analysis of your return on investment.

Industrial Solutions



Worldwide Support



Quality Manufacturing



Customer Service

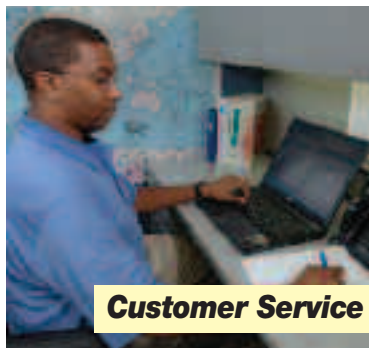

BearingSaver®



Mobile Equipment



Research & Development



<i>Introduction to Centro-Matic®</i>	2
<i>Grease Injectors</i>	5
<i>Oil Injectors</i>	11
<i>Metric Injectors</i>	15
<i>Injector Accessories</i>	16
<i>P653S Electric Pump</i>	18
<i>P603S Pump</i>	20
<i>Manual Grease Pumps</i>	22
<i>Air-Operated Grease Pumps</i>	23
<i>Electric Grease Pumps</i>	27
<i>Manually Operated Oil Pumps</i>	27
<i>Air-Operated Oil Pumps</i>	28
<i>Electric-Operated Oil Pumps</i>	30
<i>Bucket Pumps</i>	31
<i>FlowMaster® Hydraulic Pump</i>	32
<i>FlowMaster® Electric Pumps</i>	33
<i>Hydraulic-Powered Grease Pumps</i>	36
<i>Airless Spray Systems</i>	37
<i>Pump Accessories</i>	39
<i>System Controls</i>	41
<i>Numerical Index</i>	49

Lincoln Centro-Matic® systems and components are made to match your application. Systems can service one machine, different zones on one machine or even several separate machines. Regardless of the application, the principle of centralized lubrication remains the same: a central pump station automatically delivers lubricant through a single supply line to the injectors. Each injector serves only one lubrication point and may be accurately adjusted to deliver the precise amount of grease or oil required. Centro-Matic systems give you multiple advantages over other designs.

Simplicity

Systems are easy to understand, install and maintain. You realize savings right from the start because one lubricant supply line means lower installation costs.

Powerful Pumping Unit

Centro-Matic systems dispense either grease or oil in measured quantities, unaffected by normal temperature or viscosity changes. For large systems, Lincoln's single-line design and powerful pumps mean injectors can be located long distances from original refinery containers or bulk lubricant tanks.

External Adjustment

Lubricant injectors are externally adjustable without special tools so each bearing can receive the correct amount of lubricant. No under- or over-lubrication at individual points.

Visual Indicators

Each injector incorporates an indicator pin that gives visual confirmation the injector is operating correctly. When necessary, troubleshooting is the simple process of checking indicator pins.

Ease of Service

When injectors finally need service, the job is quick and easy. No need to remove supply line connections or disturb adjacent injectors. Replacement can usually be done between lubrication cycles, so there's almost no lubricant loss or downtime.

Parts and Service

You're never far from a Lincoln authorized distributor. Qualified distributors offer design engineering, startup help and training for your personnel in the use and maintenance of Centro-Matic systems. They'll back you up with parts and service for years after the sale.

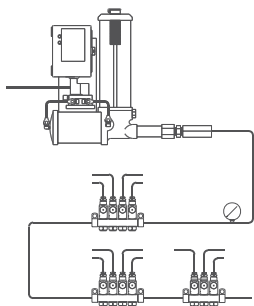

Air-Operated

Actuated automatically by compressed air at various pre-determined intervals. An air-operated pump delivers lubricant to the injectors. When all injectors have cycled, the pump shuts off automatically and vents lubricant pressure. Available with automatic, manual or mechanical controls.

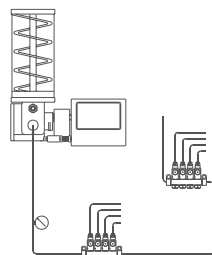

Electric

Used where compressed air is not available, or electrical operation is preferred. Totally enclosed motor supplies the power requirements of the pumping mechanism. Time control is adjustable to provide predetermined frequency of lubrication.

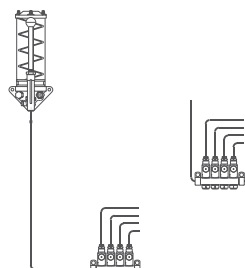

Manual

Designed for smaller, individual machines, manual systems provide a low-cost, efficient method of distributing lubricant to the injectors. Cycling a complete bank of injectors takes only a few seconds. In manually-operated systems, the lubricant pump is hand-operated and the machine operator performs the lubrication intervals.

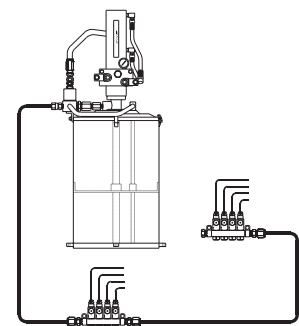

Hydraulic

A complete hydraulically-powered pumping unit for centralized lubrication of individual machines. Usually installed on machinery such as coal mining and earth moving equipment which utilize a hydraulic pressure system. The frequency of the lubrication cycle can be set manually or by mechanical or automatic controls.

Basic Operating Principles of Centro-Matic® Injectors

Each Lincoln Centro-Matic injector can be manually adjusted to discharge the precise amount of lubricant each bearing needs. Injectors are mounted singly at each bearing, or grouped in a manifold with feedlines supplying lubricant to the bearings. In each case, injectors are supplied with lubricant under pump pressure through a single supply line. Two injector types are available: a top adjusting and a side adjusting. Both types can be used in the same circuit; their selection is made on the basis of bearing lubricant requirements.

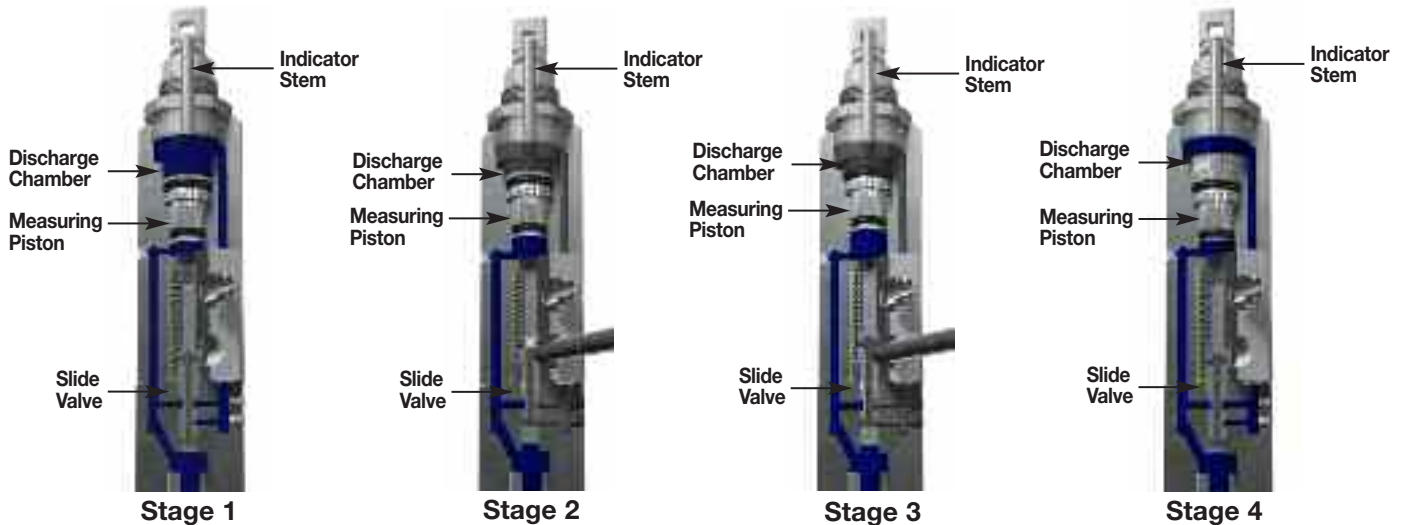

SL-V, SL-V XL

Stage 1—The discharge chamber is filled with lubricant from the previous cycle. Under pressure of incoming lubricant, lubricant is directed to both sides of the measuring piston through the slide valve. The port to the bearing is closed in this position which prevents the measuring piston from moving. The indicator stem will be at its innermost position, having pulled away from the stop in the adjusting screw.

Stage 2—Pressure has built up and has moved the slide valve in position shown. This closes the flow passage to the upper side of the piston (larger diameter) while simultaneously opening the port to allow lubricant to flow out of the injector to the bearing. Pressure from the supply line continues to apply pressure to the lower portion of the measuring piston, which causes a pressure difference across the measuring piston thus allowing it to move upward.

Stage 3—Movement of the measuring piston is shown caused by the pressure on the lower side of the measuring piston dispensing lubricant out to the bearing. The indicator stem will move up against the stop in the adjusting screw when all lubricant has been delivered to the bearing.

Stage 4—As the pressure in the supply line is vented down to 1,000 psi, the slide valve moves back to its rest position. Flow of lubricant to the bearing is closed and simultaneously allows lubricant to flow to the upper (larger diameter) of the piston. The displacement of fluid on the lower side of the measuring chamber is also allowed by the slide valve to flow to the upper side of the piston. The injector is recharged by the residual pressure in the supply line to the upper portion of the measuring chamber.

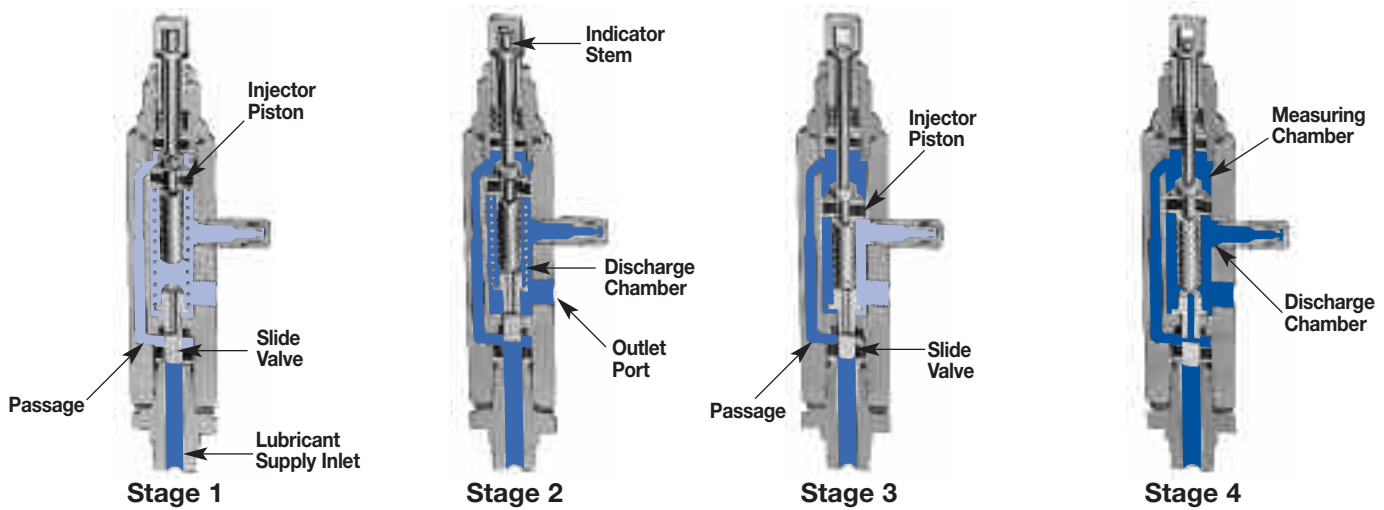

SL-1, -11, -41, -44

Stage 1—The injector piston is in its normal, or rest position. The discharge chamber is filled with lubricant from the previous cycle. Under the pressure of incoming lubricant, the slide valve is about to open the passage leading to the piston.

Stage 2—When the slide valve uncovers the passage, lubricant is admitted to the top of the piston, forcing the piston down. The piston forces lubricant from the discharge chamber through the outlet port to the bearing.

Stage 3—As the piston completes its stroke, it pushes the slide valve past the passage, cutting off further admission of lubricant to the passage. Piston and slide valve remain in this position until lubricant pressure in the supply line is vented (relieved) at the pump.

Stage 4—After pressure is relieved, the compressed spring moves the slide valve to the closed position. This opens the port from the measuring chamber and permits the lubricant to be transferred from the top of the piston to the discharge chamber.

SL-32, -33, -42, -43

Stage 1—Incoming lubricant, under pressure from the supply line, moves the injector piston forward. The piston forces a pre-charge of lubricant from the discharge chamber through the outlet check valve to the feed line.

Stage 2—When the system is vented (pressure relieved), the piston returns to the rest position, transferring lubricant from the measuring chamber to the discharge chamber.

Applications—When it comes to eliminating costly, manual point-by-point lubrication, Centro-Matic systems have proven to be the right solution for many industries and applications. Examples include:

- Paper Converting
- Printing
- Food & Beverage
- Plastic Processing
- Packaging
- Metalworking
- Wood Processing
- Textile
- Material Handling Equipment

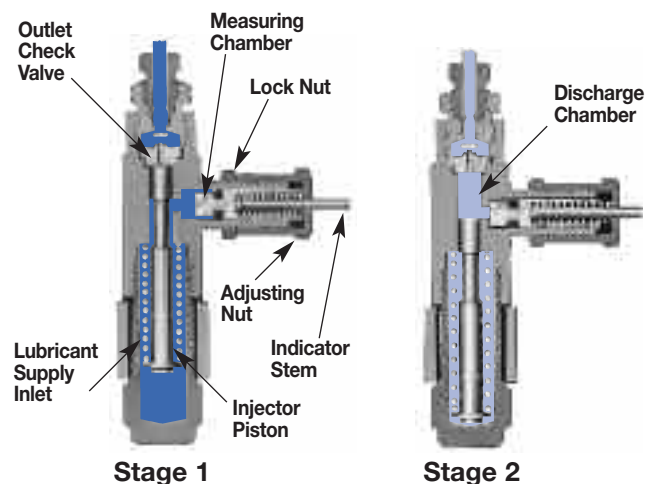

Series SL-33

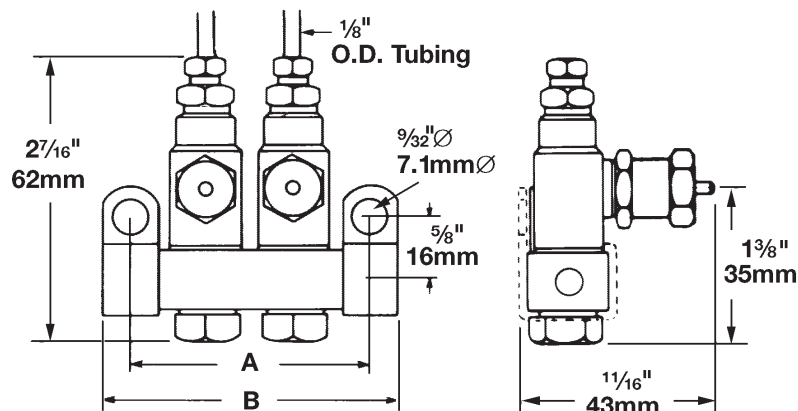

- For single-line, high-pressure central lubrication system.
- For dispensing petroleum-based lubricants with a viscosity up to NLGI No. 2 (refer to Design Guide).
- Output is externally adjustable.
- Indicator stem permits visual check of injector operation.
- May be combined in a circuit of Injectors SL-32, SL-V, SL-V XL, SL-1 and/or SL-11.
- Individual injectors can be easily removed for inspection or replacement.
- Available in stainless steel SAE 304, for application where environmental conditions are hazardous to carbon steel or in industries preferring stainless steel.

Specifications:

Series	Output		Operating Pressure			
	Min.	Max.	Min.	Max.	Typical	Vent
SL-33	.001 cu. in. .016 cc	.003 cu. in. .049 cc	1200 psig 83 bar	3500 psig 241 bar	1500 psig 103 bar	200 psig 14 bar

Model		Number of Outlets	Connections		Dimensions			
Carbon Steel	Stainless Steel (304)		Manifold Inlet	Injector Outlet	A		B	
				in.	mm	in.	mm	
83309-1	83715-1	1	1/8" NPTF (F)	1/8" O.D. Tube	1 1/8"	29	1 1/8"	41
83309-2	83715-2	2			1 1/4"	48	2 1/8"	60
83309-3	83715-3	3			2 1/8"	67	3 1/8"	79
83309-4	83715-4	4			3 1/8"	86	3 3/8"	98
83309-5	—	5			4 1/8"	105	4 3/8"	117
83309-6	83715-6	6			4 3/8"	124	5 1/8"	137
—	83715-7	7			5 1/8"	143	6 1/8"	156
83900	83900-9	1	1/8" NPTF (M)	Single Injector/No Manifold				
83314	83314-9	—	—	Single Replacement Injector				

Notes:

1. Injectors, except replacement injectors for manifold, include compression nut and ferrule for tubing — 1/8" O.D. as standard. Other outlet connectors for feed line optional.
2. Injectors with manifolds include two mounting clips and screws.
3. Injectors have Nitrile packings (200°F max. / 93°C). Check packing compatibility with synthetic lubricants.
4. Output with indicator cap hand-tightened is .001 cu. in. Maximum output is achieved with two turns at .001 cu. in./turn.

Series SL-32

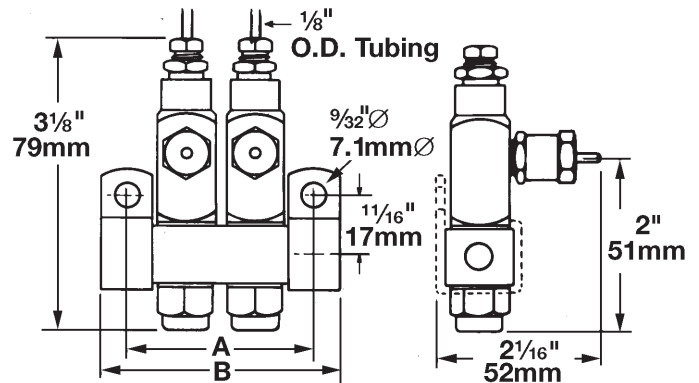

- For single-line, high-pressure central lubrication system.
- For dispensing petroleum-based lubricants with a viscosity up to NLGI No.2 (refer to Design Guide).
- Output is externally adjustable.
- Indicator stem permits visual check of injector operation.
- May be combined in a circuit of injectors SL-33, SL-V, SL-V XL, SL-1 and/or SL-11.
- Individual injectors can be easily removed for inspection or replacement.
- Available in stainless steel SAE 304, for application where environmental conditions are hazardous to carbon steel or in industries preferring stainless steel.

Specifications:

Series	Output		Operating Pressure			
	Min.	Max.	Min.	Max.	Typical	Vent
SL-32	.001 cu. in. .016 cc	.008 cu. in. .131 cc	1200 psig 83 bar	3500 psig 241 bar	1500 psig 103 bar	200 psig 14 bar

Model		Number of Outlets	Connections		Dimensions			
Carbon Steel	Stainless Steel (304)		Manifold Inlet	Injector Outlet	A		B	
					in.	mm	in.	mm
83336-1	83724-1	1	1/4" NPTF (F)	1/8" O.D. Tube	1 1/4	32	1 1/4	44
83336-2	83724-2	2			2	51	2 1/2	63
83336-3	83724-3	3			2 3/4	70	3 3/4	83
83336-4	83724-4	4			3 1/2	89	4	102
83338	—	1	1/4" NPTF (M)		Single Injector/No Manifold			
83337	83337-9	—	—		Single Replacement Injector			

Notes:

1. Injectors, except replacement injectors for manifold, include compression nut and ferrule for tubing — 1/8" O.D. as standard. Other outlet connectors for feed line optional.
2. Injectors with manifolds include two mounting clips and screws.
3. Injectors have Nitrile packings (200°F max. / 93°C). Check packing compatibility with synthetic lubricants.
4. Output with indicator cap hand-tightened is .001 cu. in. Maximum output is achieved with five turns at .0014 cu. in./turn.

Series SL-V

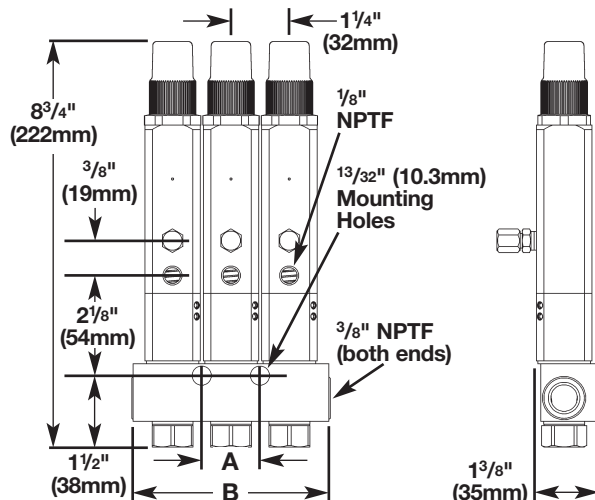

- For single-line, high-pressure central lubrication system.
- For dispensing lubricants compatible with polyurethane seals up to NLGI No. 2 (refer to Design Guide).
- Output is externally adjustable.
- Indicator stem permits visual check of injector operation.
- May be combined in a circuit of injectors SL-32, SL-33, SL-1, SL-V XL and/or SL-11.
- Individual injectors can be easily removed for inspection or replacement.
- Each SL-V injector includes a clear polycarbonate protective cap.

Specifications:

Series	Material	Output		Operating Pressure				Connections	
		Min.	Max.	Min.	Max.	Typical	Vent	Manifold Inlet	Injector Outlet
SL-V	Carbon Steel	0.015 cu. in. 0.25 cc	0.08 cu. in. 1.31 cc	1850 psig 128 bar	6000 psig 415 bar	2500 psig 170 bar	1000 psig 70 bar	3/8" NPTF (F)	1/8" NPTF (F)

Model	Type	Number of Outlets	Dimension A		Dimension B	
			in.	mm	in.	mm
85770-1	One Injector Manifold	1	Single Mounting Hole		2 1/2	63
85770-2	Two Injector Manifold	2			3	76
85770-3	Three Injector Manifold	3	1 1/4	32	4 1/4	108
85770-4	Four Injector Manifold	4	2	63	5 1/2	140
85770-5	Five Injector Manifold	5	3 3/4	95	6 3/4	171
85770-6	Six Injector Manifold	6	5	127	8	203
85771	Replacement for manifold injectors					
85772	Single injector/no manifold (3/8" NPTF(M) inlet)					

Notes:

1. Injector manifolds have 1/2" (10.3 mm) dia. mounting holes for 3/8" bolt.
2. Injectors have polyurethane seals Check compatibility with synthetic lubricants.
3. Injector rated for 180°F (80°C) max. ambient temperature, depending on lubricant used.
4. Injectors include fitting for filling feedlines via alternate outlet port.
5. Output with adjustment screw hand-tightened is .015 cu. in. Maximum output is achieved with five turns at .014 cu. in./turn.

Series SL-V XL High-Output

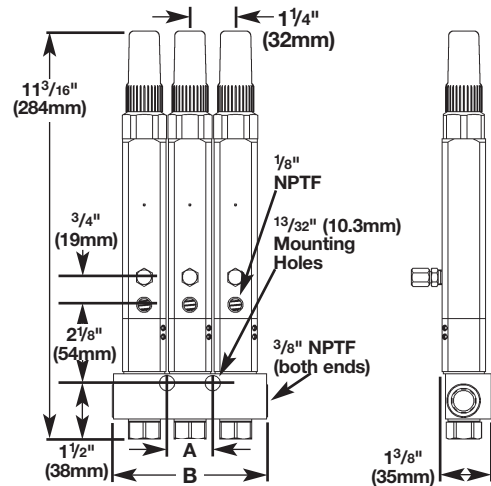

- For single-line, high-pressure central lubrication system.
- For dispensing lubricants compatible with polyurethane seals up to NLGI No. 2 (refer to Design Guide).
- Output is externally adjustable.
- Indicator stem permits visual check of injector operation.
- May be combined in a circuit of injectors SL-32, SL-33, SL-1, SL-V and/or SL-11.
- Individual injectors can be easily removed for inspection or replacement.
- Two SL-V XL injectors are required to replace one SL-11 injector.
- Each SL-V XL injector includes a clear polycarbonate protective cap.

Specifications:

Series	Material	Output		Operating Pressure				Connections	
		Min.	Max.	Min.	Max.	Typical	Vent	Manifold Inlet	Injector Outlet
SL-V XL	Carbon Steel	0.015 cu. in. 0.25 cc	0.305 cu. in. 5.00 cc	1850 psig 128 bar	6000 psig 413 bar	2500 psig 172 bar	1000 psig 69 bar	3/8" NPTF (F)	1/8" NPTF (F)

Model	Type	Number of Outlets	Dimension A		Dimension B	
			in.	mm	in.	mm
85780-1	One Injector Manifold	1	Single Mounting Hole		2 1/2	63
85780-2	Two Injector Manifold	2	Single Mounting Hole		3	76
85780-3	Three Injector Manifold	3	1 1/4	32	4 1/4	108
85780-4	Four Injector Manifold	4	2 1/2	63	5 1/2	140
85780-5	Five Injector Manifold	5	3 3/4	95	6 3/4	171
85780-6	Six Injector Manifold	6	5	127	8	203
85781	Replacement for manifold injectors					
85782	Single injector/no manifold (3/8" NPTF(M) inlet)					

Spectrum Adjustment Sleeves:

Model Number (10/bag only)	Output in ³ (cc)	Ratio from Minimum Output	Ratio from Maximum Output	Sleeve Color
N/A	0.015 (0.25)	1	0.05	NA
85785-1	0.030 (0.50)	2	0.10	red
85785-2	0.045 (0.75)	3	0.15	silver
85785-3	0.060 (1.00)	4	0.20	gold
85785-4	0.075 (1.25)	5	0.25	green
85785-5	0.113 (1.88)	7.5	0.37	black
85785-6	0.150 (2.50)	10	0.50	purple
85785-7	0.188 (3.13)	12.5	0.62	blue
85785-8	0.225 (3.75)	15	0.75	orange
85785-9	0.263 (4.38)	17.5	0.87	brown
85785-10	0.300 (5.00)	20	1.00	yellow

Notes:

1. Injector manifolds have 13/32" (10.3 mm) dia. mounting holes for 3/8" bolt.
2. Injectors have polyurethane seals Check compatibility with synthetic lubricants.
3. Injector rated for 180°F (80°C) max. ambient temperature, depending on lubricant used.
4. Injectors include fitting for filling feedlines via alternate outlet port.
5. Output with adjustment screw hand-tightened is .015 cu. in. Maximum output is achieved with 20 1/2 turns at .014 cu. in./turn.

Series SL-1

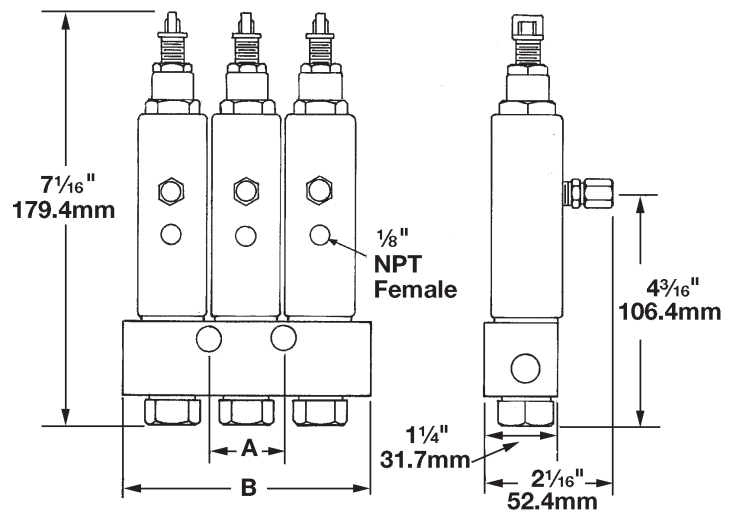

- For single-line, high-pressure central lubrication system.
- For dispensing lubricants compatible with Viton® packings and viscosity up to NLGI No. 2 (refer to Design Guide).
- Output is externally adjustable.
- Indicator stem permits visual check of injector operation.
- May be combined in a circuit of injectors SL-32, SL-33, SL-V, SL-V XL and/or SL-11.
- Individual injectors can be easily removed for inspection or replacement.
- Available in stainless steel SAE 316, for application where environmental conditions are hazardous to carbon steel or in industries preferring stainless steel.

Specifications:

Series	Output		Operating Pressure				Connections	
	Min.	Max.	Min.	Max.	Typical	Vent	Manifold Inlet	Injector Outlet
SL-1	.008 cu. in. .131 cc	.080 cu. in. 1.31 cc	1850 psig 127 bar	3500 psig 241 bar	2500 psig 172 bar	600 psig 41 bar	3/8" NPTF (F)	1/8" NPTF (F)

Model		Number of Outlets	Dimensions			
Carbon Steel	Stainless Steel (316)		A	B	A	B
			in	mm	in	mm
81770-1	239351* One Injector Manifold	1	Single Mounting Hole		2 1/2	63
81770-2	239352* Two Injector Manifold	2	Single Mounting Hole		3	76
81770-3	239353* Three Injector Manifold	3	1 1/4	32	4 1/4	108
81770-4	239354* Four Injector Manifold	4	2 1/2	63	5 1/2	140
81770-5	239355* Five Injector Manifold	5	3 1/4	95	6 3/4	171
81770-6	—	6	5	23	8	203
81713	—	Single injector/no manifold, [3/8" NPTF (M) inlet]				
81713A	84776* Injector	Replacement for manifolded injectors				

* For complete assembly, you must order stainless steel manifold and corresponding quantity of Model #84776 Injectors separately.

Notes:

1. Injector manifolds have 1 3/32" (10.3 mm) dia. mounting holes for 3/8" bolt.
2. Injectors have Viton® packings. Check compatibility with synthetic lubricants.
3. Injector rated for 350°F (176°C) max. ambient temperature, depending on lubricant used.
4. Injectors include fitting for filling feedlines via alternate outlet port.
5. Output with adjustment screw hand-tightened is .009 cu. in. Maximum output is achieved with eight turns at .009 cu. in./turn.

Series SL-11

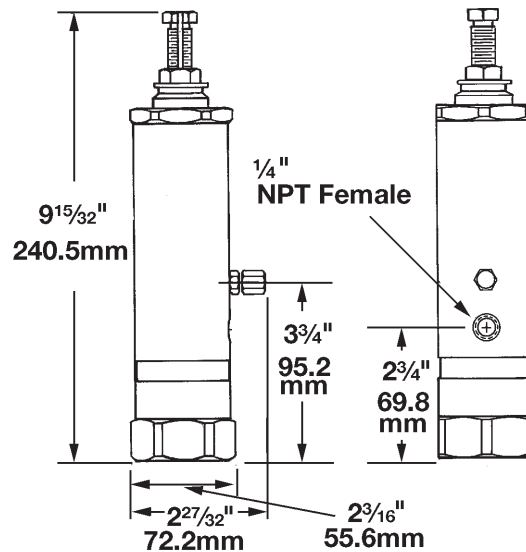

- For single-line, high-pressure central lubrication system.
- For dispensing lubricants compatible with Viton® packings and viscosity up to NLGI No. 2 (refer to Design Guide).
- Output is externally adjustable.
- Indicator stem permits visual check of injector operation.
- May be combined in a circuit of injectors SL-32, SL-33, SL-V, SL-V XL and/or SL-1.
- Available only as single unit with $\frac{1}{2}$ " NPTF Female inlet.

Specifications:

Series	Output		Operating Pressure			
	Min.	Max.	Min.	Max.	Typical	Vent
SL-11	.050 cu. in. .82 cc	.500 cu. in. 8.2 cc	1000 psig 69 bar	3500 psig 241 bar	2500 psig 172 bar	800 psig 55 bar

Carbon Steel	Number of Outlets	Connections	
		Inlet	Outlet
85497	1	$\frac{1}{2}$ " NPTF (F)	$\frac{1}{4}$ " NPTF (F)

Notes:

1. Injectors have Viton® packings. Check packing compatibility with synthetic lubricants.
2. Injector rated for 350°F (176°C) max. ambient temperature.
3. Injectors supplied with fitting for filling feed line via alternate outlet port.
4. Output with adjustment screw hand-tightened is .05 cu. in. Maximum output is achieved with 11½ turns at .040 cu. in./turn.

Series SL-42

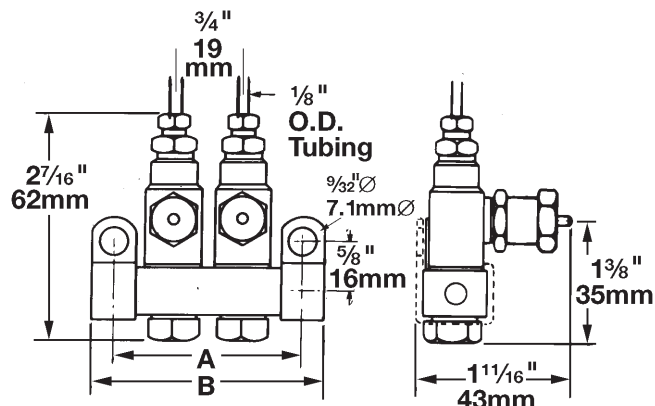

- For single-line central lubrication system.
- For dispensing fluid or semi-fluid lubricants.
- Output is externally adjustable.
- Indicator stem permits visual check of injector operation.
- May be combined in a circuit of injectors SL-43, SL-41 and/or SL-44.
- Individual injectors can be easily removed for inspection or replacement.
- Carbon steel injectors with Nitrile or Viton® packings.
- Injectors with Viton® packings are used for heat resistant applications or when lubricant to be dispensed requires Viton® packings for compatibility (indicated by black adjustment caps).

Specifications:

Series	Output		Operating Pressure			
	Min.	Max.	Min.	Max.	Typical	Vent
SL-42	.001 cu. in. .016 cc	.003 cu. in. .049 cc	750 psig 52 bar	1000 psig 69 bar	850 psig 59 bar	150 psig 10 bar

Model		Number of Outlets	Connections		Dimensions			
Standard	Heat Resistant		Manifold/ Injector Inlet	Injector Outlet	A		B	
					in.	mm	in.	mm
83311-1	84428-1	1	1/8" NPTF (F)	1/8" O.D. Tube Connection	1 1/8"	29	1 1/8"	41
83311-2	84428-2	2			1 1/4"	48	2 1/8"	60
83311-3	84428-3	3			2 1/8"	67	3 1/8"	79
83311-4	84428-4	4			3 1/8"	86	3 3/8"	98
83311-5	84428-5	5			4 1/8"	105	4 3/8"	117
83311-6	84428-6	6			4 3/8"	124	5 1/8"	137
83311-10	84428-10	10			7 1/8"	200	8 3/8"	213
83311-15	84428-15	15			11 1/8"	295	12 3/8"	308
83535	—	1	1/8" NPTF (M)		Single Injector/No Manifold			
83313	84048	—	—		Replacement for Manifold Injectors			

Notes:

1. Injectors, except replacement injectors for manifold, include compression nut and ferrule for tubing – 1/8" O.D. as standard. Other outlet connectors for feed line optional.
2. Injectors with manifolds include two mounting clips and screws.
3. Standard injectors have Nitrile packings (200°F/93°C max.); Heat Resistant injectors have Viton® packings (350°F/176°C max., depending on lubricant used) and black adjusting cap. Check packing compatibility with synthetic lubricants.
4. Output with indicator cap hand-tightened is .001 cu. in. Maximum output is achieved with two turns at .001 cu. in./turn.

Series SL-43

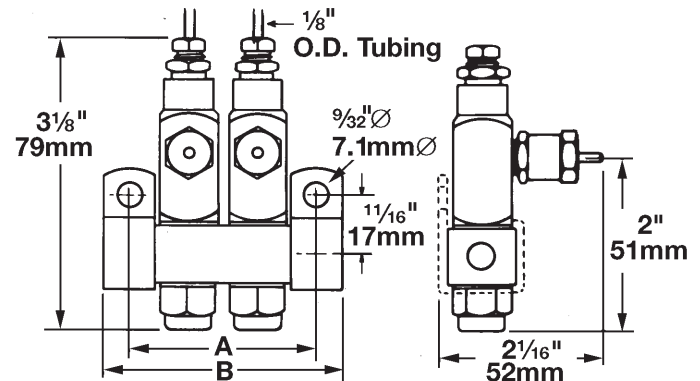

- For single-line central lubrication system.
- For dispensing fluids or semi-fluid lubricants.
- Output is externally adjustable.
- Indicator stem permits visual check of injector operation.
- May be combined in a circuit of injectors SL-42, SL-41 and/or SL-44.
- Individual injectors can be easily removed for inspection or replacement.
- Carbon steel injectors with Nitrile or Viton® packings.
- Injectors with Viton® packings are used for heat resistant applications or when lubricant to be dispensed requires Viton® packings for compatibility (indicated by black adjustment caps).

Specifications:

Series	Output		Operating Pressure			
	Min.	Max.	Min.	Max.	Typical	Vent
SL-43	.001 cu. in. .016 cc	.008 cu. in. .131 cc	750 psig 52 bar	1000 psig 69 bar	850 psig 59 bar	150 psig 10 bar

Model		Number of Outlets	Connections		Dimensions			
Carbon Steel			Manifold/ Injector Inlet	Injector Outlet	A		B	
Standard	Heat Resistant				in.	mm	in.	mm
83661-1	84429-1	1	¼" NPTF (F)	½" O.D. Tube Connection	1¼	32	1¼	44
83661-2	84429-2	2			2	51	2½	63
83661-3	84429-3	3			2¾	70	3¼	83
83661-4	84429-4	4			3½	89	4	102
83660	84110	—	—	—	Replacement for Manifold Injectors			

Notes:

1. Injectors, except replacement injectors for manifold, include compression nut and ferrule for tubing – 1/8" O.D. as standard. Other outlet connectors for feed line optional.
2. Injectors with manifolds include two mounting clips and screws.
3. Standard injectors have Nitrile packings (200°F/93°C max.)
4. Heat Resistant injectors have Viton® packings (350°F/176°C max. depending on lubricant used) and Black Adjusting Cap.
5. Check packing compatibility with synthetic lubricants.
6. Output with indicator cap hand-tightened is .001 cu. in. Maximum output is achieved with five turns at .0014 cu. in./turn.

Series SL-41

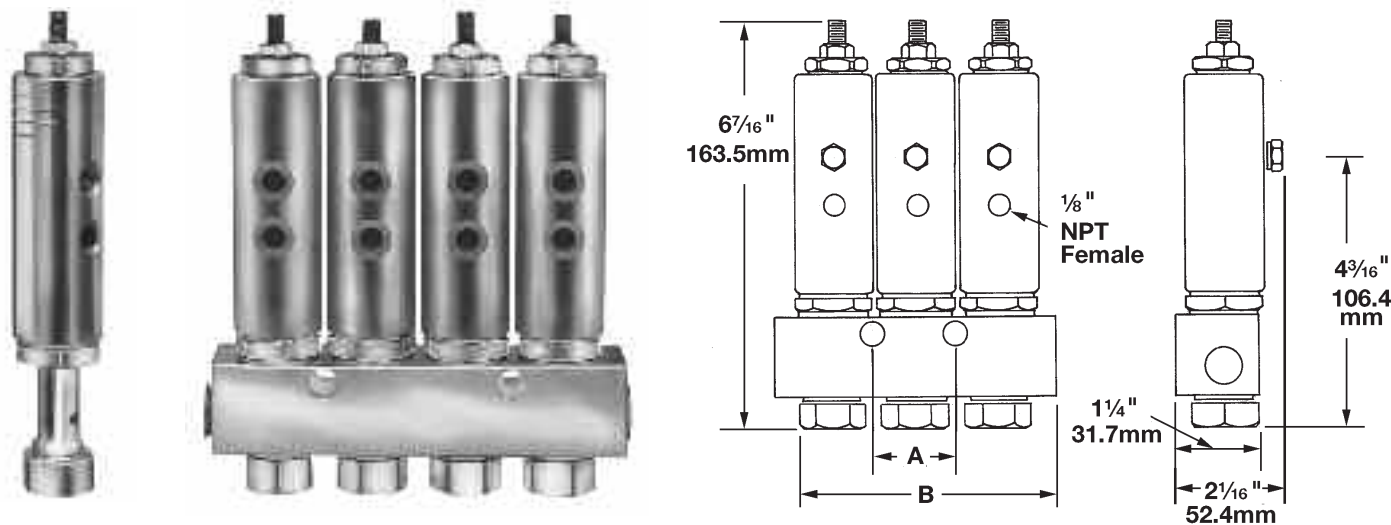

- SL-41 series injectors are designed for use in high temperature applications up to 350°F (176°C), depending on lubricant.
- Available installed only in manifolds with 3/8" NPT female inlet.
- Injectors feature a tamper-resistant adjustment screw which does not incorporate a visual indicator.
- May be combined in a circuit of injectors SL-42, SL-43 and SL-44.

Specifications:

Series	Output		Operating Pressure			
	Min.	Max.	Min.	Max.	Typical	Vent
SL-41	.008 cu. in. .131 cc	.080 cu. in. 1.31 cc	750 psig 52 bar	1000 psig 69 bar	850 psig 59 bar	150 psig 10 bar

Model	Number of Outlets	Connections		Dimensions			
		Manifold/ Injector Inlet	Injector Outlet	A		B	
				in.	mm	in.	mm
82294-1	1	3/8" NPTF (F)	1/8" NPTF (F)	Single Hole Mounting		2 1/2	63
82294-2	2					3	76
82294-3	3			1 1/4	32	4 1/4	108
82294-4	4			2 1/2	63	5 1/2	140
82294-5	5			3 3/4	95	6 3/4	171
82292	Single Injector/No Manifold, [3/8" NPTF (M) Inlet]						
82295	—	—	1/8" NPTF (F)	Replacement for Manifold Injectors			

Notes:

1. Injector manifolds have 13/32" (10.3 mm) mounting holes for 3/8" bolt.
2. Minimum output (.008 cu. in.) is achieved by hand tightening the adjustment screw, then backing out 9 turns. Maximum output (.08 cu. in.) is achieved by hand tightening the adjustment screw, then backing out 16 turns.

Series SL-44

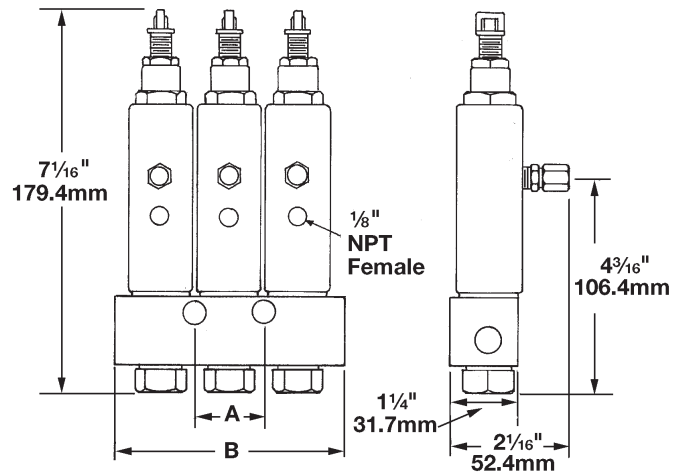

- For single-line central lubrication system.
- For dispensing fluid or semi-fluid lubricants.
- Output is externally adjustable.
- Indicator stem permits visual check of injector operation.
- May be combined in a circuit of injectors SL-43, SL-41 and/or SL-42.
- Individual injectors can be easily removed for inspection or replacement.
- Carbon steel injectors with Viton® packings.

Specifications:

Series	Output		Operating Pressure			
	Min.	Max.	Min.	Max.	Typical	Vent
SL-44	.008 cu. in. .131 cc	.080 cu. in. 1.31 cc	750 psig 52 bar	1000 psig 69 bar	850 psig 59 bar	150 psig 10 bar

Model	Number of Outlets	Connections		Dimensions			
		Manifold Inlet	Injector Outlet	A		B	
				in.	mm	in.	mm
83749-1	1	3/8" NPTF (F)	1/8" NPTF (F)	Single Hole Mounting		2 1/2	63
83749-2	2			3	76		
83749-3	3			1 1/4	32	4 1/4	108
83749-4	4			2 1/2	63	5 1/2	140
83749-5	5			3 3/4	95	6 3/4	171
83748	1	—	—	Replacement for Manifold Injectors			

Notes:

1. Injector manifolds have 1 3/32" mounting holes for 3/8" bolt.
2. Injectors have Viton® packings. Check packing compatibility with synthetic lubricants.
3. Injectors rated at 350°F (176°C) maximum ambient temperature, depending on lubricant used.
4. Output with adjustment screw hand-tightened is .009 cu. in. Maximum output is achieved with eight turns at .009 cu. in./turn.

Series SL-32, 33 and 42 Metric

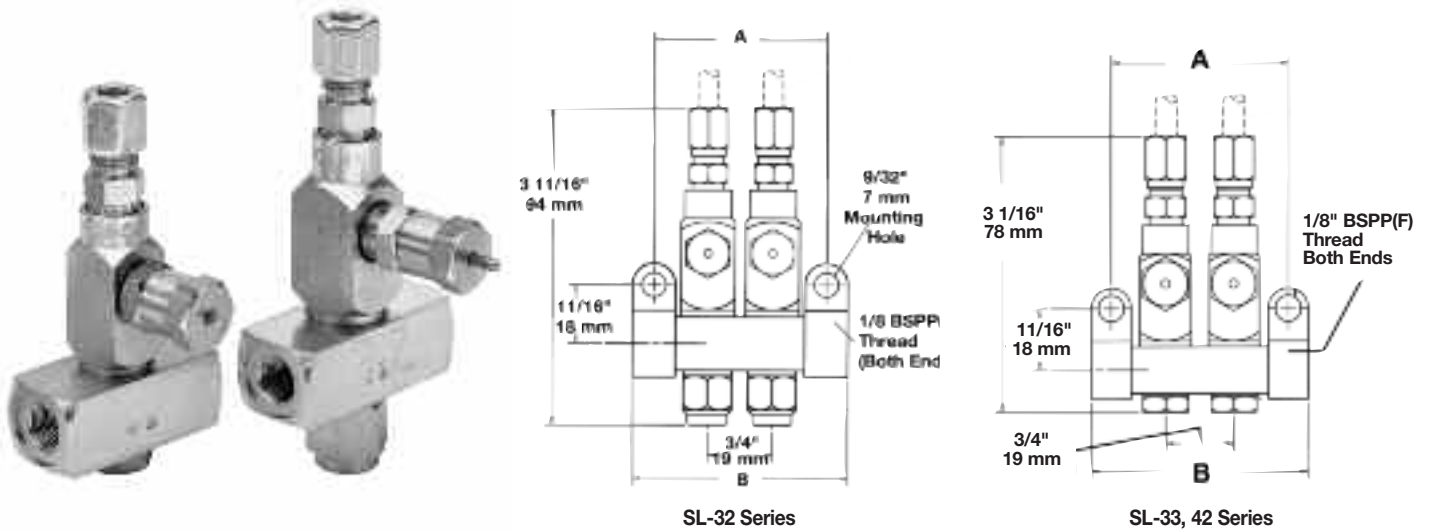

With the same proven design as our U.S. standard injectors, the new metric versions of our popular small grease and oil injectors feature metric ports. Any surface that needs a wrench is metric. It's more convenient for customers in most of the world, and easier to maintain because there's no need for a second set of wrenches or adapters.

- Offered for international customers.
- Metric ports connect with metric lines without adapters.
- No need for a second set of tools.
- Proven design used in the United States.
- Models for both grease and oil.

Specifications:

Model			Outlets	Connections		Dimension A		Dimension B	
Oil SL-42	Grease SL-33	Grease SL-32		Inlet	Outlet	in.	mm	in.	mm
85352-1	85351-1		1	1/8" BSPP(F)	6 mm O.D. Tube Connection	1 1/8"	29	1 1/8"	41
85352-2	85351-2		2			1 1/4"	48	2 1/8"	60
85352-3	85351-3		3			2 1/8"	67	3 1/8"	79
85352-4	85351-4		4			3 1/8"	86	3 3/8"	98
85352-5	85351-5		5			4 1/8"	105	4 3/8"	118
85352-6	85351-6		6			4 3/8"	124	5 1/8"	137
		85353-1	1			1 1/4"	32	1 3/8"	44
		85353-2	2			2	51	2 1/2"	64
		85353-3	3			2 3/8"	70	3 1/4"	83
		85353-4	4			3 1/8"	89	4	102



Injector Connector Tube

Permits application of combined discharge of two or more Series SL-V, SL-1, SL-41 or SL-44 injectors through one feed line. Used where bearing size is such that multiple injector output is required. Fittings 1/8" NPT male each end. Carbon steel construction.

Model	For Injector Series	Connections
81646	SL-V, SL-V XL OR SL1, SL41, SL44	1/8" NPTF Male
274824	SL-1 to SL-V connection	1/8" NPTF Male



Injector Outlet Adapter

Converts individual injector lubricant outlet when standard 1/8" O.D. tube is not desired. All adapters are carbon steel unless otherwise noted.

Model	For Injector Series	Outlet Connections
14988	SL32, SL33, SL42, SL43	1/8" NPTF Female
84200		1/4" O.D. Tube
14991		1/8" NPTF Male
249281		4 mm Tube
249282		6 mm Tube



Manual Grease Fitting Adapter

Allows manual lubrication of the machine between normal system cycles. Carbon steel with Nitrile seals.

Model	For Injector Series	Outlet Connections
84195	SL32, SL33, SL42, SL43	1/8" O.D. Tube
84203		1/4" O.D. Tube



Injector Locking Cap

Carbon steel locking caps set injectors to fixed output.

Model	For Injector Series	Fixed Volume Output
102781	SL32, SL43	.002 in ³ / .033 cc
	SL33, SL42	.003 in ³ / .049 cc



Injector Cover Caps

Injector cover caps are designed to protect the injector from dirt, harmful liquids and fumes.

Model	Fits Injector Series	Covers	Material	Length		Diameter	
				in	mm	in	mm
273088	SL-V	Indicator Stem	Polycarbonate	1.5	38.1	.715(ID)	18.2
273089	SL-V XL			2.2	55.9	.715(ID)	18.2
83272	SL1, SL44		Vinyl	1.5	38.1	.69(ID)	17.5
83730	SL11	2.0		50.8	1.125(ID)	28.6	
68483	SL32, SL33, SL42, SL43	Measuring Chamber	Aluminum	1.25	31.2	.5(ID)	12.7
90537	SL1, SL41, SL44	Injector Body		3.25	82.6	1.19(ID)	30.2

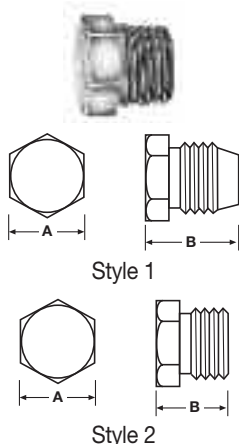

Closure Plugs for Injectors and Manifolds

For use in plugging lubricant outlets of injectors and manifolds.

Model	Material	Thread Size (in)	A in. / mm	B in. / mm	Style
12698*	Carbon Steel	3/16" -24	3/16" / 7.9	1/2" / 12.7	1
12698-9*	Stainless Steel				
12511	Carbon Steel	1/8" PTF	3/16" / 11.1	3/16" / 11.1	2
12511-9	Stainless Steel				
67044	Carbon Steel	3/8" NPT	3/16" / 11.1	13/16" / 20.6	2
67007		1/4" NPT			
67007-9					

* For plugging outlet of series SL-32, SL-33, SL-42, SL-43 injectors.

Compression Nuts

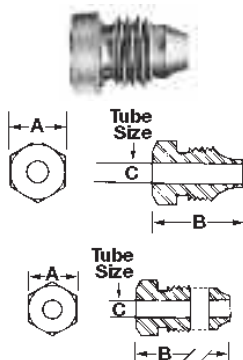

Model	Style	Material	Thread Size (in)	A in. / mm	B in. / mm	C in. / mm
66260	One Piece	Brass	3/16"-24	3/16" / 7.9	1/2" / 12.7	1/8" / 3.2
66260-9		Stainless Steel				
83924	Two Piece	Brass	3/16"-24	3/16" / 7.9	1/2" / 12.7	1/8" / 3.2
83924-9		Stainless Steel				
66713	One Piece	Brass	3/16"-24	3/16" / 11.1	5/8" / 15.9	1/4" / 6.3

Injector-Operated Air Valve



Model	For Injector Series	Air Inlet	Air Outlet
82272	SL-1, SL-44	1/8" NPTF(F)	1/8" NPTF(F)

Air Lubricant Spray Devices



Model	Use With Series	Air Inlet (in)	Lubricant Inlet (in)	Spray Outlet	Air Consumption		
68421	SL1, SL44	1/4" NPTF Female	1/4" NPTF Female	Fixed Nozzle	3.5 CFM	4.1 CFM	5.2 CFM
69456				Swivel Nozzle	@40 PSI	@60 PSI	@80 PSI
68587*				Bulkhead Mount	99 l/min	116 l/min	147 l/min
84204	SL32, SL33, SL42, SL43	1/4" NPTF Female	3/16" - 24 Male	Fixed Nozzle	Throttle Controlled		

* 3/16" (4.8 mm) maximum bulkhead thickness.

Metric Outlet Adapters

Adapts injector outlet to 4 or 6 mm tubing.

Conversion Kit Model No.	Tubing Size	Material	Nut	Ferrule
249281	4 mm	Carbon Steel	249277	249271
249282	6 mm	Carbon Steel	249274	249273

Assembly comes with one nut and one ferrule.



Model 68874

Feedline Brush

Use to apply lubricant to chains and conveyors. 1/8" NPT(F) inlet, 1" long, 5/8" surface area diameter; aluminum body with nylon bristles.

Taking Lincoln's Pump Performance and Dependability In A Totally New Direction

The fully integrated P653S pump is an example of Lincoln's commitment to providing innovative, cost-effective solutions through industry-leading advances in technology. This next-generation, lower-cost pump package can be fitted with one of four reservoir sizes and easily adapts to many applications.



P653S Pump Features

- Integrated pump supplies lubricant to a single line parallel lubrication system
- Pumps low- and high-viscosity greases including industry standard NLGI grade 2 grease
- Easily interfaces with telematics technology in today's heavy equipment
- Operating temperature range from -40°F to +158°F (-40°C to +70°C) VDC or 32°F to 122°F (0°C to 50°C) VAC*
- Neutral switch allows mobile equipment to remain idling with pump power on but the timer is deactivated – allowing manual lubrication functionality.

Benefits

- Integration of major system components reduces labor and overall costs
- Simplifies lubrication system design
- Installation time is reduced due to the "plug-and-play" pump design. Simply mount the pump, connect power and the supply lines and the system is ready for operation.
- Neutral switch ensures lubrication only when the machine is operating – eliminating wasted grease.

* Appropriate greases apply

Available With or Without Follower (shown with follower)

High-Volume Output

Vent Valve

120/220-AC or 24-DC Pump



INTERNAL COMPONENTS

- Telematics Signaling Capabilities for Low Level and System Fault Detection
- Pressure Switch or Transducer

Reservoir Available in Four Sizes – 4, 8, 15, and 20 Liters Means Versatility in Scheduling Refilling Service Intervals

Reservoir Refill Port

Programmable Controller

Centro-Matic® Automated Lubrication Systems

P653S Electric Pump



P653S Pump Specifications

Electrical data	DC Pumps	AC Pumps
Incoming voltage:	19 to 31 VDC	100 to 240 VAC
Maximum current:	10 amps	1.7 amps
Frequency:	—	47 to 63 hz
Operating temperature:	-40°F to +158°F (-40°C to +70°C)	32°F to 122°F (0°C to 50°C)

Common Electrical Data for DC and AC Pumps

Minimum pause time:	4 min.
Maximum pause time:	59 hrs. 59 min.
Pause time increments:	1 hr. or 1 min.
Maximum pumping time:	10 min.

Pump P653S

Operating pressure with:	
Pressure switch:	3,500 psig (240 bar)
Pressure transducer (adj.):	1,400 to 4,600 psig (96 to 317 bar)
End of line pressure switch and transducer setting:	2,500 psig (172 bar)
Number of outlets:	1
Output:	1.5 in ³ /min (24.6 cm ³ /min)

Pump Elements

Piston diameter:	7 mm
Number of pumping elements (connected together):	3

Available Pump Models

NOTE: All models are designed for grease and include stirring paddle and low-level detection. Pumps include remote signaling cable, relief valve, electrical connectors and external pressure switch or transducer (as indicated for each model).

Model No.	24 VDC	120/230 VAC 50/60 Hz	Reservoir Size (L)	Follower Plate	Internal Pressure Switch	Internal Pressure Transducer	Internal & End-of-Line Pressure Switch	Internal & End-of-Line Pressure Transducer
80086	X		4		X			
80087	X		4			X		
80105	X		4				X	
80106	X		4					X
80076	X		4	X	X			
80077	X		4	X		X		
80109	X		4	X			X	
80110	X		4	X				X
80090	X		8		X			
80091	X		8			X		
80107	X		8				X	
80108	X		8					X
80080	X		8	X	X			
80081	X		8	X		X		
80111	X		8	X			X	
80112	X		8	X				X
80082		X	4		X			
80083		X	4			X		
80084		X	4				X	
80085		X	4					X
80072		X	4	X	X			
80073		X	4	X		X		
80074		X	4	X			X	
80075		X	4	X				X
80088		X	8		X			
80089		X	8			X		
80078		X	8	X	X			
80079		X	8	X		X		

The Path to Cost Reduction

A lack of lubrication can bring your machines and equipment to a screeching halt. Manual lubrication is often awkward and expensive. Automated lubrication offers an efficient, rational and environmentally friendly solution.

From a few lubrication points to a few thousand – Lincoln offers the complete range of lubrication equipment and systems for professional lubrication of construction and mining equipment.

Lincoln lubrication systems are based on the principle of grouping lubrication points together that can be serviced from one supply point. Our modules build upon each other – enabling the system to grow in accordance with our customer's requirements. This enables us to offer a custom-tailored lubrication solution for individual needs.



P603S Pump Features

Reliable Operation in Harsh Environments

- Wind turbines – especially offshore
- Construction and mining
- Commercial vehicles
- Compact and medium-sized machines and industrial applications
- Robust and easy system layout
- Simple maintenance – easy to expand
- SE1 suction elements for used lubricant
- Suitable for quick separating lubricants
- Increased profits and productivity
- Improved operating times; less costly downtime resulting from improper lubrication
- Lower costs for repairs and spare parts
- Exactly matched metering reduces the cost of lubricant
- Precise metering reduces the environmental impact. No dripping of “too much” lubricant
- Improved safety by minimizing slipping
- Hard-to-reach points are easily accessible from a convenient point – which also improves safety
- Reliable supply of all connected lubrication points. No points are “overlooked”

P603S Pump Specifications

Incoming metering:	0.05 - 0.4 cm ³ /stroke
Pump output:	12 cm ³
Supply voltage:	12 VDC, 24 VDC, 100-240 VAC
Visual monitoring (indicator pin):	x
Programmable controller:	x
Reservoir capacity/liter:	4, 8, 10, 15, 20
Integrated pressure sensor and vent:	x
Visual low-level:	x
Compatible with SE1 suction elements:	x

Available Pump Models

Model No.	Description	Power	Size	Follower	Transducer
645-41064-3	P603S- 4XLF -3Z7-AC-2A7.16-S13-SE	AC	4L	X	X
645-41062-3	P603S- 8XLF -3Z7-AC-2A7.16-S13-SE	AC	8L	X	X
645-41110-2	P603S- 8XLBO-3Z7-AC-3A7.16-S12-SE	AC	8L		X
645-41062-4	P603S- 8XLBO-3Z7-AC-3A7.16-S19-SE	AC	8L		X
645-41062-3	P603S- 8XLF -3Z7-AC-2A7.16-S13-SE	AC	8L	X	X
645-41073-5	P603S-15XLF -3Z7-AC-2A7.16-S13-SE	AC	15L	X	X
645-41064-8	P603S- 4XLF1-3Z7-12-1A7.16-S01-SE	12 DC	4L	X (Bayonett)	X
645-41064-7	P603S- 4XNBO-3Z7-12-2A7.16-S01-SE	12 DC	4L		X
645-41110-3	P603S- 8XLF1-3Z7-12-1A7.16-S01-SE	12 DC	8L	X (Bayonett)	X
645-41062-9	P603S- 8XLF -3Z7-24-1A7.16-S01-SE	24 DC	8L	X	X
645-41064-4	P603S- 4XLBO-3Z7-24-1A7.16-S17-SE	24 DC	4L		X
645-41064-6	P603S- 4XLF -3Z7-24-1A7.16-S13-SE	24 DC	4L	X	X
645-41064-2	P603S- 4XNBO-3Z7-24-1A7.16-S01-SE	24 DC	4L		X
645-41062-8	P603S- 8XLBO-3Z7-24-2A7.16-S19-SE	24 DC	8L		X
645-41062-9	P603S- 8XLF -3Z7-24-1A7.16-S01-SE	24 DC	8L	X	X
645-41062-7	P603S- 8XLF -3Z7-24-1A7.16-S03-SE	24 DC	8L	X	X
645-41119-1	P603S-10XLF -3Z7-24-1A7.16-S13-SE	24 DC	10L	X	X



Pump and Accessories – All-In-One

The pump with integrated controller is easy to install. The all-in-one design of the pump includes the programmable controller, a pressure switch/transducer and a vent valve.

Simple System Design – Easy to Expand

The single-line system's design and layout is uncomplicated, making it easy to install and operate. A single mainline reduces material and installation costs.

Easy to Service

It is quick and easy to exchange out an injector. The mainline or neighboring injectors do not have to be removed. The exchange can be performed between lubrication cycles so that there is no wastage of lubricant or excessive costly downtime.

Additional Pressure Switch

An additional pressure switch at the end of larger systems can be used for added pressure control to ensure correct lubrication

Special Features for Wind Turbine Applications – Also for Off-Shore Systems

Lincoln single-line systems completely vent during the pause interval. As a result, they are suitable for fast separating lubricants.

For rotating operation in wind turbines the reservoir is equipped with a follower plate and stirring paddle – which also facilitates the usage of fast separating lubricants. For stationary operation a stirring and fixed paddle is sufficient.

Pump Specifications

	P603S 12/24 VDC	P603S / AC
Pump output	0.73 cu.in/min (12cm ³ /min)	0.73 cu.in/min (12cm ³ /min)
Maximum working pressure	4,350 psig (300 bar) / 3,480 psig (240bar)	4,350 psig (300 bar) / 3,480 psig (240bar)
Maximum current draw	2 amps	2 amps
Steering paddle and follower	yes	yes
Reservoir size, liter	4, 8, 10, 15 and 20	4, 8, 10, 15 and 20
Number of pumping elements	3, (seven millimeter dia.)	3, (seven millimeter dia.)
RPM, paddle (76 F)	18	18
Pressure switch at pump	yes	yes
Transducer at pump	yes	yes
Pressure switch/ end of line	yes	yes
Transducer/end of line	yes	yes
PCB	yes	yes
Separate alarms, LL/Proxy switch	no	no
24.0 VDC input	yes	yes
Switching power supply	no	yes
Connectors	Bayonets style	Bayonets style + square type (AC)
Data logger	no	no
Remotely change lube frequency	yes	yes
Count control	yes	yes
Ignition & Neutral Switch	yes	yes
Acknowledging fault	at pump/external	at pump/external
Manually lub switch, external	yes	yes
Pump on LED, external	yes	yes
Protetecion	IP 6K9K	IP 6K9K
Temperature	-40°C / +70°C	-40°C / +70°C

Once you have determined your total lubricant requirements, your greatest line length and compensated for line expansion, you're ready to determine the pump you need.

If your overall requirements are less than 2.4 cu. in. for oil or 2.15 cu. in. for grease, you can select a single stroke pump. Should your requirements demand more capacity, a reciprocating pump will fill the need.

Your Lincoln representative will suggest the best pump for you based on your application. Look over the following pages of pump selection options and feel free to ask questions.



Model 83817 Economy Grease Pump

Manual pump has metal reservoir and spring-loaded follower. Indicator pin in pump base shows when 2500 psi system operating pressure has been achieved.

Model:	83817	
Output/Stroke:	.100 cu. in.	1.6 cc
Reservoir Capacity:	1 lb.	.45 kg
	30 cu. in.	492 cc
Lube Outlet:	1/8" NPTF (F)	
Typical System	Min. 1200 psig	82 bar
Operating Pressure:	Max. 3500 psig	241 bar
Dimensions (HxWxL):	15 1/4" x 5" x 5 5/8"	387 x 127 x 141 mm
Filling Method:	14.6 oz. Grease Cartridge/Bulk Fill	

Model 1810 Grease Pump

Translucent reservoir with spring-loaded follower. Indicator pin in pump base shows when 2500 psi system operating pressure has been achieved. Refill through included fitting using Model 81834 filler pump or other manual pump equipped with Model 645006 coupler.

Model:	1810	
Output/Stroke:	.160 cu. in.	2.6 cc
Reservoir Capacity:	5 lb.	2.27 kg
	150 cu. in.	2458.50 cc
Lube Outlet:	1/4" NPTF (F)	
Typical System	Min. 1200 psig	82 bar
Operating Pressure:	Max. 3500 psig	241 bar
Dimensions (HxWxL):	16 1/4" x 7 1/8" x 7 3/4"	413 x 181 x 197 mm
Filling Method:	81834 Filler Pump	

Centro-Matic® Integrated Pumps

All models are air-operated, positive displacement pumps delivering a maximum volume by means of a single stroke of the pump (volumes listed below). Solenoid air valves and adjustable solid-state time controls are integrated into the pump body. All pumps are designed to deliver grease to single-line injectors and include a special high-volume refill fitting. Acrylic reservoirs are available in several sizes. Integrated controls feature LED indicators for “Power On”, “Pump On” and “Alarm,” along with a membrane-type, “Manual Lube” switch.



Model 85434

Model 85434 Integrated Grease Pump

Ratio:	31:1	
Power:	120 VAC	
Typical System	Min. 1200 psig	82 bar
Operating Pressure:	Max. 3500 psig	240 bar
Maximum Output:	1.4 in ³	18.7 cm ³
Reservoir Capacity:	4.5 lbs.	1.8 kg
Dimensions (LxWxH):	24.70" x 6.52"x 18.11"	627 x 166 x 460 mm

Model 85435 Integrated Grease Pump

Same as Model 85434 except 240 VAC.

Model 85436 Integrated Grease Pump

Same as Model 85434 except with a Ratio of 25:1 and Maximum Output of 2.15 in³ (35.2 cm³).



Model 85442

Model 85442 Integrated Grease Pump

Ratio:	20:1	
Power:	120 VAC	
Typical System	Min. 1200 psig	82 bar
Operating Pressure:	Max. 3500 psig	240 bar
Maximum Output:	0.45 in ³	7.4 cm ³
Reservoir Capacity:	1 lb.	0.450 kg
Dimensions (LxWxH):	5.25" x 7.24"x 12.02"	133 x 184 x 305 mm

Model 85444 Integrated Grease Pump

Ratio:	20:1	
Power:	120 VAC	
Typical System	Min. 1200 psig	82 bar
Operating Pressure:	Max. 3500 psig	240 bar
Maximum Output:	0.45 in ³	7.4 cm ³
Reservoir Capacity:	4 lbs.	1.8 kg
Dimensions (LxWxH):	5.25" x 7.24"x 20.75"	133 x 184 x 527 mm

Model 85445 Integrated Grease Pump

Same as Model 85444 except 240 VAC.



Timer and Controller Specifications

On Time	Off Time	Alarm Contacts	Operating Temperature
10 sec or 30 sec	1/2 to 30 min or 30 min to 30 hrs	8 amps @ 250 VAC	-10°F to 150°F -23°C to 65°C



Model 82886



Model 83668

Model 82886 Pump

Pump discharges lubricant on air-powered forward stroke and vents on spring-powered return stroke through built-in check/vent valve. Reservoir is translucent with spring-loaded follower. Includes filler fitting for refilling reservoir with Model 81834 or other manual pump equipped with Model 645006 coupler.

Model 83668

Same as Model 82886 except includes larger reservoir.

Model 82653 Bare Pump

Pump uses air for forward and return stroke but dispenses lubricant on forward stroke only. Return stroke vents lubricant pressure through included check/vent valve. Translucent reservoir has spring-loaded follower. Refill through included filler fitting using Model 81834 or other manual pump equipped with Model 645006 coupler.

Model 83834 High Volume Bare Pump

Same as Model 82653 except 25:1 ratio, 2.15 cu. in (35.2 cc) maximum output.

Model 82655 Pump with Controls

Same as Model 82653 except includes Model 84501 solid state timer and 350244 four way electric solenoid valve.

Model 83800 High Volume Pump with Controls

Same as Model 83834 except includes Model 84501 solid state timer and 350244 four way electric solenoid valve.



Model 82653

Model	Lubricant/ Air Ratio	Max. Output	Reservoir Capacity	Reservoir Temp. Range	Air Inlet	Lube Outlet	Lubricant Oper. Pressure		Dimensions HxWxL	Air Valve Required
							Min.	Max.		
82886	20:1	.45 in ³ 7.4 cm ³	1 lb/.45 kg 30 in ³ /492 cm ³	0°F to 150°F -18°C to 65°C	¼" NPTF(F)	¼" NPTF(F)	1200 psig 82 bar	3500 psig 240 bar	10 ³ / ₈ " x 5 ¹ / ₄ " x 6	3-way
83668									263x133x152mm	
82653	3:1	1.4 in ³ 22.9 cm ³	4 lb/1.81 kg 120 in ³ / 1967 cm ³						18 ¹ / ₂ " x 5 ³ / ₄ " x 21 470x146x533mm	4-way
82655										
83834	83800									

Note: Air consumption @ 100 psi is .15 CFM per stroke.

Timer Specifications

Cycle Time		On Time		Power Requirements	Ambient Operating Temp. Range
Min	Max	Min	Max		
20 Sec.	24 Hr.	10 Sec.	1 Min. 24 Sec.	120 VAC, 60 hz 110 VAC, 50 hz	-10°F to +150°F -23°C +65°C

Note:

Refer to System Controls section for detailed timer and solenoid operated air valve specifications.



Model 83167

Includes transparent reservoir, spring-loaded follower, vent valve assembly and filler fitting for refilling of reservoir with 81834 filler pump or other manual pump equipped with Model 645006 coupler.

Model:	83167	
Lubricant/Air Ratio:	40:1	
Output/Min @ 100 PSIG Air:	12 cu. in.	197 cc
Reservoir Capacity:	12 lb. / 5.44 kg	360 cu. in. / 5900 cc
Air Inlet:	1/8" NPTF (F)	
Lube Outlet:	3/4" NPTF (F)	
Typical System	Min. 1200 psig	82 bar
Operating Pressure:	Max. 3500 psig	241 bar
Dimensions (HxWxL):	22 1/2" x 9" x 16 1/4"	572 x 229 x 413 mm
Filling Method:	81834 Filler Pump	
Reservoir:	Translucent Acrylic	

Notes: 1. Pump requires 3-way air valve. 2. Air consumption @ 100 psi is .15 CFM per cycle



Model 83599

Same as Model 83167 except includes base mounting kit and metal reservoir with indicator rod for visual check of grease level. Reservoir includes spring-loaded follower.

Model:	83599	
Lubricant/Air Ratio:	40:1	
Output/Min @ 100 PSIG Air:	12 cu. in.	197 cc
Reservoir Capacity:	12 lb. / 5.44 kg	360 cu. in. / 5900 cc
Air Inlet:	1/4" NPTF (F)	
Lube Outlet:	3/4" NPTF (F)	
Typical System	Min. 1200 psig	82 bar
Operating Pressure:	Max. 3500 psig	241 bar
Dimensions (HxWxL):	24 3/8" x 9" x 18 3/16"	619 x 229 x 462 mm
Filling Method:	81834 Filler Pump	
Reservoir:	Aluminum	

Notes: 1. Pump requires 3-way air valve. 2. Air consumption @ 100 psi is .15 CFM per cycle



Model 1823

Includes 2½" air motor driven pump, vent valve assembly, pump elevator, connecting lubricant and air hoses, and control panel.

Model:	1823	
Lubricant/Air Ratio:	50:1	
Output/Min @ 100 PSIG Air:	30 cu. in.	492 cc
Drum Size:	U.S. standard 120 lb. refinery drum	
Air Inlet:	¾" NPTF (F)	
Lube Outlet:	¾" NPTF (F)	
Typical System	Min. 1200 psig	82 bar
Operating Pressure:	Max. 3500 psig	241 bar
Components	Pump & Vent Assembly	282288
Included:	Controller	85209
	Pump Elevator	83447

Controller Electrical Requirements: 120V, 60 Hz., 110 V, 50hz

Notes: 1. Air consumption @ 100 psi is .42 CFM per cycle.

2. Model 83371 follower plate is available as an optional accessory.



Model 282288

Same specifications as Model 1823 but does not include elevator or controller.

Model 1827 Heavy-Duty Unit

Consists of PowerMaster pump, vent valve assembly with air and lubricant connecting hoses, drum cover and control panel.



Model:	1827	
Lubricant/Air Ratio:	75:1	
Output/Min @ 100 PSIG Air:	161 cu. in.	2638 cc
Drum Size:	U.S. standard 400 lb. refinery drum	
Air Inlet:	¾" NPTF (F)	
Lube Outlet:	¾" NPTF (F)	
Typical System	Min. 1200 psig	82 bar
Operating Pressure:	Max. 3500 psig	241 bar
Components	Basic Pump	2004
Included:	Vent Valve	85215
	Controller	85209
	Drum Cover	81675

Model 1828

Same as Model 1827 except includes Model 2008 pump, 85218 vent valve and Model 84034 drum cover sized for U.S. standard 120 lb. refinery drum. Includes 85209 controller.

Model 1829

Same as Model 1827 except includes Model 2010 pump (50:1 ratio, 231 cu. in./min. (3785 cc) delivery at 100 psig air). Fits U.S. standard 400 lb. refinery drum. Includes 85209 controller and 85215 vent valve.





Model 1849

Fully automatic assembly including pump, 220/440 volt motor, translucent reservoir with spring-loaded follower, 4000 psi (276 bar) safety unloader, adjustable pressure switch and time control. Time control is adjustable for lubrication cycle frequency of 5, 10, 15, 20, 30 or 60 minutes. Solid state time delay relay (35 sec. to 240 sec.) included for connection of audible or visual alarm to signal lubrication failure due to empty reservoir or broken supply line.

Model:	1849 *	
Output/Min:	18 cu. in.	295 cc
Reservoir Capacity:	12 lb. / 5.44 kg	360 cu. in. / 5900 cc
Lube Outlet:	¼" NPTF (F)	
Electrical Specifications:		
Pump Motor	220/440 VAC, 60 Hz, 3 ph	
Controller	115 VAC, 60 Hz	
Typical System	Min. 1200 psig	82 bar
Operating Pressure:	Max. 3500 psig	241 bar
Dimensions (HxWxL):	25 ³ / ₈ " x 13" x 19 ¹³ / ₁₆ "	645 x 330 x 503 mm
Reservoir Fill Method:	81834 Filler Pump or Manual Pump and 645006 Coupler	

* See Model 85520 in Systems Control section for controller specifications.

Model 1835

Same as Model 1849 except has 115 VAC, 60 Hz motor and controller.

Model 1833

Similar to Model 1849 except: 24 VDC pump motor and controller; metal reservoir with visual level indicator rod; 2.5, 5, 10, 20, 40 and 80 minute cycle frequency adjustment; 60 second fixed on time and alarm relay features. Incorporates pressure switch factory set at 2500 psi (172 bar).

Model:	1833	
Output/Min:	18 cu. in.	295 cc
Reservoir Capacity:	12 lb. / 5.44 kg	360 cu. in. / 5900 cc
Lube Outlet:	¼" NPTF (F)	
Electrical Specifications:		
Pump Motor	¼ HP, 24 VD, 10 AMP	
Controller	24 VDC, 5 watts	
Typical System	Min. 1200 psig	82 bar
Operating Pressure:	Max. 3500 psig	241 bar
Dimensions (HxWxL):	34 ¹ / ₄ " x 11 ¹ / ₂ " x 21 ¹ / ₄ "	870 x 292 x 552 mm
Reservoir Fill Method:	81834 Filler Pump or Manual Pump with 645006 Coupler	

Notes:

1. Controller has provision for remote manual lube button and remote lube failure alarm.
2. Enclosure is designed to meet NEMA 3S and 12 specifications.



Manually-Operated Oil Pump

Model 1812

Pump has translucent reservoir with filler cap and strainer. Pump base has built-in check/vent valve and an indicator pin to show when system pressure is achieved.

Model:	1812	
Output/Stroke:	.160 cu. in.	2.6 cc
Reservoir Capacity:	4½ pint /130 cu. in.	2.13 liter/2130 cc
Lube Outlet:	¼" NPTF (F)	
Typical System	Min. 750 psig	52 bar
Operating Pressure:	Max. 1000 psig	69 bar
Dimensions (HxWxL):	16 ³ / ₄ " x 7 ¹ / ₈ " x 7 ³ / ₄ "	425 x 181 x 197 mm

Note: Check compatibility when using synthetic oils.



Centro-Matic® Integrated Pumps

All models are air-operated, positive displacement pumps delivering a maximum volume by means of a single stroke of the pump (volumes listed below). Solenoid air valves and adjustable solid-state time controls are integrated into the pump body. All pumps are designed to deliver fluid lubricants to single-line injectors and are filled via a spring-loaded filler cap and internal filter. Acrylic reservoirs are available in several sizes. Pump Models 85432 and 85433 do not include a reservoir, and are designed for remote or bulk-fill oil applications (80 psi/5.4 bar maximum head pressure). Integrated controls feature LED indicators for “Power On”, “Pump On” and “Alarm,” along with a membrane-type, “Manual Lube” switch.



Model 85430

Model 85430 Integrated Fluid Pump

Ratio:	20:1	
Power:	120 VAC	
Typical System Operating Pressure:	Min. 750 psig	52 bar
	Max. 1000 psig	69 bar
Maximum Output:	2.4 in ³	39.3 cm ³
Reservoir Capacity:	4.5 pints	2.1 liters
Dimensions (LxWxH):	24.70" x 6.52" x 18.11"	627 x 166 x 460 mm



Model 85432

Model 85431 Integrated Fluid Pump

Same as Model 85430 except 240 VAC.

Model 85432 Integrated Fluid Pump

Same as Model 85430 except without reservoir.

Model 85433 Integrated Fluid Pump

Same as Model 85432 except 240 VAC.



Model 85438

Model 85438 Integrated Fluid Pump

Ratio:	20:1	
Power:	120 VAC	
Typical System Operating Pressure:	Min. 750 psig	52 bar
	Max. 1000 psig	69 bar
Maximum Output:	0.45 in ³	7.4 cm ³
Reservoir Capacity:	1.25 pints	0.6 liters
Dimensions (LxWxH):	5.25" x 7.24" x 12.02"	133 x 184 x 305 mm

Model 85440 Integrated Fluid Pump

Ratio:	20:1	
Power:	120 VAC	
Typical System Operating Pressure:	Min. 750 psig	52 bar
	Max. 1000 psig	69 bar
Maximum Output:	0.45 in ³	7.4 cm ³
Reservoir Capacity:	4.25 pints	2.0 liters
Dimensions (LxWxH):	5.25" x 7.24" x 20.75"	133 x 184 x 527 mm

Model 85441 Integrated Fluid Pump

Same as Model 85440 except 240 VAC.



Model 85440

Timer and Controller Specifications

On Time	Off Time	Alarm Contacts	Operating Temperature
10 sec or 30 sec	1/2 to 30 min or 30 min to 30 hrs	8 amps @ 250 VAC	-10°F to 150°F -23°C to 65°C

Centro-Matic® Automated Lubrication Systems

Air-Operated (Single-Stroke) Oil Pumps



Model 82885



Model 83667



Model 82676

Model 82885

Pump discharges lubricant on air-powered forward stroke and vents on spring-powered return stroke through built-in check/vent valve. Translucent reservoir is refilled through filler cap with strainer.

Model 83667

Same as Model 82885 except includes larger reservoir.

Model 82570

High-volume pump discharges lubricant on air-powered forward stroke and vents through included check/vent valve on air-powered return stroke. Translucent reservoir is refilled through filler cap with strainer.

Model 82573

Air-operated, single stroke oil pump and timer assembly. Same as Model 82570 except includes Model 84501 solid state timer and 350244 four-way electrical solenoid valve. Power requirements: 120 VAC, 60 Hz; 110 VAC, 50 Hz.

Model 82676

Same as Model 82570 except for use with external oil supply through ½" NPT(F) oil inlet (maximum head pressure 80 psi (5.5 bar)).

Model	Metric Equiv	Lubricant/ Air Ratio	Max Output	Reservoir Capacity	Air Inlet	Lube Outlet	Lubricant Oper. Press.		Dimensions HxWxL	Air Valve Required
							Min	Max		
82885	85391	20:1	.45 in ³ 7.4 cm ³	1¼ pint / 6 liter 36 in ³ / 600cm ³	¼" NPTF(F)	¼" NPTF(F)	750 psig 52 bar	1000 psig 69 bar	10¾"x5¼"x6" 263x133x152mm	3-way
83667	4½ pint / 2 liter 123 in ³ / 2000 cm ³		18½"x5½"x6" 470x140x152mm							
82570	Remote		2.4 in ³ 39.3 cm ³	Remote					17¾"x5¾"x18¼" 451x146x464mm	4-way
82573									18½"x5¾"x21" 470x146x533mm	
82676										

** Air consumption @ 100 psi is .15 CFM per stroke.
Check compatibility when using synthetic oils.

Timer Specifications for Model 82573 Only

Cycle Time		On Time	
Min	Max	Min	Max
20 Sec.	24 Hr.	10 Sec.	1 Min. 24 Sec.

Note:

Refer to System Controls section for detailed timer and solenoid-operated air valve specifications.



Model 283167

Includes 2½" air motor driven pump, vent valve assembly, translucent reservoir with filler cap and strainer and 1200 psi (82 bar) safety unloader.

Model:	283167	
Lubricant/Air Ratio:	40:1	
Output/Min @ 100 PSI Air:	12 cu. in.	197 cc
Reservoir Capacity:	15 pint	7.1 liter
	433 cu. in.	7100 cc
Air Inlet:	½" NPTF (F)	
Lube Outlet:	¾" NPTF (F)	
Typical System	Min. 750 psig	52 bar
Operating Pressure:	Max. 1000 psig	69 bar
Dimensions (HxWxL):	23¾" x 9" x 16¼"	591 x 229 x 413 mm
Air Valve Required:	3-Way**	

** Air consumption @ 100 psi is .15 CFM per stroke.

Note: Check compatibility when using synthetic oils.



Model 1826

Consists of Model 2002 PowerMaster pump, Model 85217 vent valve assembly, Model 81675 drum cover, Model 85209 controller, air and lubricant connecting hoses and 1200 psi (82 bar) safety unloader.



Model:	1826	
Lubricant/Air Ratio:	24:1	
Output @ 75 Cycles/Min:	462 cu. in.	7571 cc
Drum Size:	U.S. standard 55-gal. refinery drum (removable head)	
Air Inlet:	¾" NPTF (F)	
Lube Outlet:	¾" NPTF (F)	
Typical System	Min. 750 psig	52 bar
Operating Pressure:	Max. 1000 psig	69 bar
Controller Electrical		
Requirements:	120 V 60 Hz, 110V 50 Hz	

Notes:

1. See System Controls section for detailed controller specifications.
2. See Industrial Pumping catalog for basic pump specification, including air consumption.

Electric-Operated Oil Pump

Model 1848

Fully automatic assembly including pump, 220-/440-volt motor, translucent reservoir, 1200 psi (82 bar) safety unloader, adjustable pressure switch and time control. Time control is adjustable for lubrication cycle frequency of 5, 10, 15, 20, 30 or 60 minutes. Solid state time delay relay (35 sec. to 240 sec.) included for connection of audible or visual alarm to signal lubrication failure due to empty reservoir or broken supply line.



Model:	1848	
Output/Min:	18 cu. in.	295 cc
Reservoir Capacity:	14.7 pint	6.96 liter
	424 cu. in.	6960cc
Lube Outlet:	¼" NPTF (F)	
Electrical Specifications:		
Pump Motor	220/440 VAC, 60 Hz, 3 ph	
Controller Max..	115 VAC, 60 Hz	
Typical System	Min. 750 psig	52 bar
Operating Pressure:	Max. 1000 psig	69 bar
Dimensions (HxWxL):	25¾" x 13" x 19¼"	645 x 330 x 503 mm
Note:	See Model 85520, System Controls section for controller specifications.	

Centro-Matic® Automated Lubrication Systems

Bucket Pumps



Lincoln offers 60, 90 or 120 lb. reservoirs for our bucket pumps. Here are the features:

- Rugged 14-gauge steel walls
- Large 3/4" NPT inlet for fast filling
- Wiper on follower plate that reduces lubricant waste
- Special coupling for easy pump removal when servicing
- Thick mounting ring that withstands severe vibration

These buckets work with hydraulic, air and electric pumps.

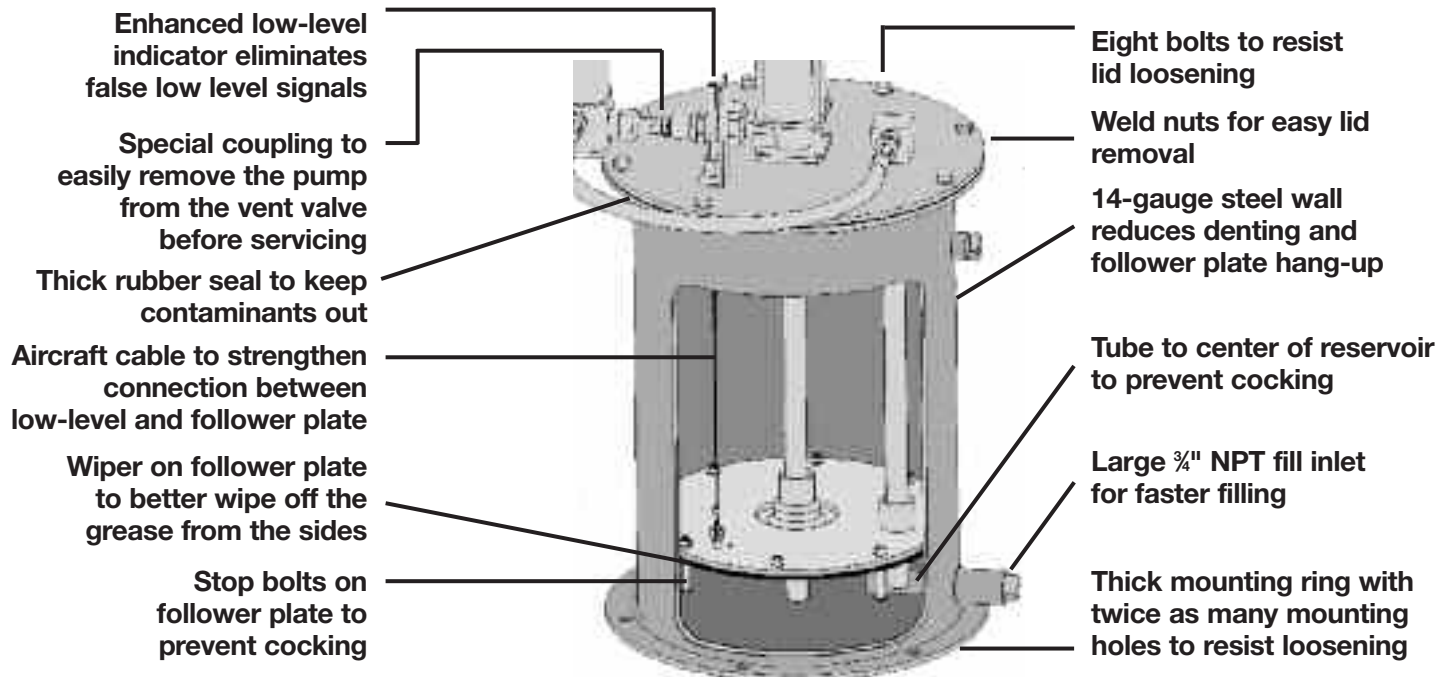

Model 84050

A 50:1 ratio double acting air-operated pump for high-volume displacement. Supplied with a 60-pound capacity metal reservoir with removable cover for easy filling. Includes air-operated vent valve and 5' (1.5m) air and lubricant connecting hoses.

Model:	84050	
Lubricant/Air Ratio:	50:1	
Output/Min @ 100 PSIG Air:	30 cu. in.	492 cc
Reservoir Capacity:	60 lb. / 27 kg	1800 cu. in. / 29,500 cc
Air Inlet:	3/8" NPTF (F)	
Lube Outlet:	1/4" NPTF (M) at Hose	
Typical System Operating Pressure:	Min. 1200 psig	82 bar
	Max. 3500 psig	241 bar
Dimensions (HxWxL):	31 3/4" x 15 1/8" x 15 1/8"	806 x 392 x 395 mm
Filling Method:	Bulk	
Reservoir:	Steel	

Notes: 1. Pump requires 3-way air valve. 2. Air consumption @ 100 psi is .42 CFM per cycle
3. Optional Model 92597 follower available.

Model 85460

Same as Model 84050 except includes installed visual low level and follower plate assembly.

Centro-Matic® Automated Lubrication Systems

FlowMaster® Hydraulic Pump

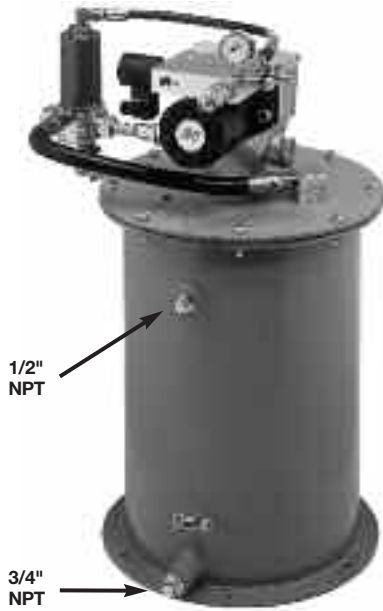

High-performance FlowMaster hydraulic pumps combine rotary-driven pump motors with reciprocating pump tubes and flexible control features that perform in desert heat and arctic cold. Integrated control manifold adjusts the amount of lubricant and operating pressure. The pump's output is adjustable from 7 to 45 cubic inches per minute.

Supply Inlet Hydraulic Pressure, Max.:	3000 psig	200 bar
Operating Inlet Hydraulic Pressure:	300 to 420 psig	20 to 32 bar
Hydraulic Inlet Flow:	Up to 7 gpm	28 l/min
Pump Ratio with Manifold:	9:1 at low inlet pressure (300 to 350 psi/20 to 25 bar) and low inlet flow (below 2 gpm/7 lpm) pump ratio approaches 11:1 ratio at higher inlet pressure and flow	
Pump Output:	7 - 45 in ³ /min	
Operating Temperature:	-20° to +150°F	-10° to +65°C
Solenoid Valve Coil:	24 VDC	
Hydraulic Inlet Port:	SAE 4	
Tank Return Port:	SAE 6	
Pump Outlets:	1/4" NPTF	
Max. Hydraulic Fluid Temp:	200°F	93°C

For the complete system, when ordering 120# or 400# versions also order the following:

120#	Drum Cover	84616
	Follower Assy	85492
	Vent Valve Assy	84990
400#	Drum Cover	271606
	Follower Assy	270982
	Vent Valve Assy	271605



Pump Only Models

Model	Capacity			Solenoid Manual Override	Adjustable Flow Control	Adjustable Pressure Control
	lbs	gal	L			
85247	120	18	68	Yes		
85480	120	18	68			
85481	60	8	30			
85482	400	55	208			
85483	35	5	19	No	Yes	Yes
85486	35	5	19			
85586*	400	55	208			
85610**	400	55	208			
85676	90	10	38	Yes	Fixed	Fixed
85678	60	8	30			
86261***	35	5	19	No	Yes	Yes

*Heavy-duty model **Low temperature model (-60°F) ***Kit consisting of pump, follower, bucket cover and hardware

Pump & Bucket Models with follower plate and low-level detect

Model	lbs	Size gal	L	Solenoid Manual Override	Adjustable Flow Control	Adjustable Pressure Control
85244**	90	10	38	Yes		
85487**	60	8	30	No	Yes	Yes
85585	90	10	38			
85677**	90	10	38	Yes	Fixed	Fixed
86258	60	8	30	No	Yes	Yes

*Includes high-level detect **Does not include follower plate or low-level detect

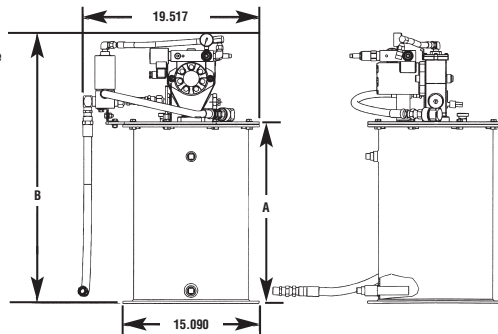
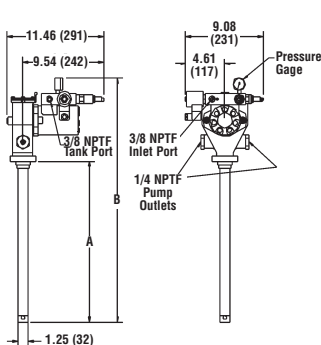

Container Size	Pump - in. (mm)		Pump Bucket-in. (mm)	
	A	B	A	B
35 lb.	13.69 (348)	23.50 (597)	14.59 (371)	24.40 (620)
60 lb.	19.00 (483)	28.81 (732)	19.90 (505)	29.70 (754)
90 lb.	27.50 (699)	37.31 (942)	28.40 (721)	40.13 (1,019)
120 lb.	27.50 (699)	37.31 (942)	28.40 (721)	40.13 (1,019)
400 lb.	34.00 (864)	43.81 (1,113)	34.00 (864)	44.94 (1,142)

Centro-Matic® Automated Lubrication Systems

FlowMaster® Electric Pumps



It seems too good to be true, but Lincoln's new Electric FlowMaster Pump can serve all but the largest automated lubrication applications. Now you can take advantage of the ease and economy of this efficient, versatile electric pump—no cost for air associated with running the pump and no hydraulic hoses to connect.

The Electric FlowMaster Pump is a workhorse. Because you can adjust the speed of the pump's motor, you can adjust the pump's output to precisely fit any application. Lincoln offers 12 different models.

For manual lubrication, use the pump with a hose reel and a dispensing valve.



24 VDC FlowMaster®

Operating Temperature Range:	-40° to +150°F	-40° to +65°C
Pump Outlets:	¼" NPTF	
Motor:	½" HP PEAK	

Pump Only Models

Model	Capacity			Power	Maximum Pressure Rating	Speed Range RPM
	lbs	gal	L			
85479	35	5	19	24 DC	2500 psi (170 bar)	9.5-100
85552	35	5	19			5-50
85553	120	18	68		5000 psi (345 bar)	9-93
85554	60	8	30			
85566	120	18	68			36-360
85567	60	8	30			
85568	120	18	68		2500 psi (170 bar)	9.5-100
85569	35	5	19		24 DC	5000 psi (345 bar)
85591	400	55	208	12 DC	3500 psi (241 bar)	300
85582	60	8	30			

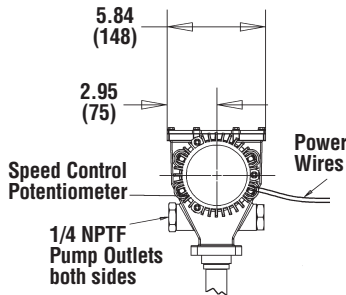

Model	Gear Ratio	Current Draw Amps	Output: in³/min	
			Min	Max
85479*	17.8:1	2-5	0.7	6.3
85552	34:1	1-4.2	0.4	3.5
85553				
85554	19:1	1-6.5	0.7	6.3
85566				
85567	5:1	2-15	2.8	25.2
85568				
85569	17.8:1	2-5	0.7	6.3
85582		31		21

* Kit consisting of pump, follower, bucket cover and hardware

Pump and Bucket Models

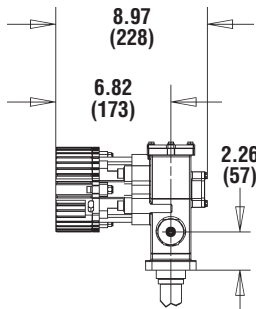

Model	Capacity			Power	Maximum Pressure Rating	Speed Range RPM
	lbs	gal	L			
85471	60	8	30	24 DC	5000 psi (345 bar)	36-360
85472	90	10	38			
85473*	120	18	68			

Model	Gear Ratio	Current Draw Amps	Output: in³/min	
			Min	Max
85471	5:1	2-15	2.8	25.2
85472				
85473				

Above models include follower plate and low-level detect

* Includes high-level detect

24 VDC Electric Vent Valve

274899	IP 67 Explosion Proof Rating
525-32083-1	IP 54 Explosion Proof Rating

Accessories

Description	120 lb.	400 lb.
Follower plate	85492	270982
Drum cover	85474	85475
Vent valve assembly: 24 VDC	85664	85665
Strainer	272180	272180



120/230 VAC FlowMaster®

Now you can save the cost of air and plug in our new 120/230 VAC FlowMaster pump. Convenient and powerful, the 120/230 VAC FlowMaster pump allows you to tap into your AC power source and pump grease from a 120 lb. or 400 lb. drum. Rely on it to drive your automated lubrication systems such as Centro-Matic®, Mod Lube®, Quicklub® and Two-line.

Operating Temperature Range:	-40° to +150°F (-40° to +65°C)
Operating Voltage:	120/230 VAC (60 Hz only)
Pump Outlets:	¼" NPTF
Motor:	½ HP

Pump Only Models

Model	Capacity			Power	Maximum Pressure Rating	Speed Range RPM
	lbs	gal	L			
85588	400	55	208	120-230 AC	5000 psi (345 bar)	360
85589	120	18	68			

Model	Gear Ratio	Current Draw: Amps		Output: in³/min	
		@120 V	@230 V	Min	Max
85588	5:1	1-4.6	.5-2.4	24.5	24.5
85589					

Accessories

Description	120 lb.	400 lb.
Follower plate	85492	270982
Drum cover	85474	85475
Vent valve assembly: 120 VAC	85662	85663
230 VAC	85660	85661
Strainer	272180	272180

Reel-N-Flow Pump and Reel Kit



Operating Temperature	-20° to +140°F (-29° to +60°C)
Operating Voltage	24 VDC (18 min., 30 max.)
Motor	1/3 HP (0.25 kw)
Max. Current Draw	15 AMPS
Max. Output	18.0 in³/min (295 cm³/min)
Max. Output Pressure	6,000 psi (413.8 bar)
Pump Weight	35 lbs. kg (15.9)
Hose Reel Capacity	3/8" High Pressure Hose, 50 ft. (15 m)

Mounts on 35#/5-gallon refinery container

Pump Models

Model	Description
274873	Bare, high-pressure pump
274874	Bare pump with integrated pressure switch and manifold

Kit Models

Model	Description	Bare Pump	Lid	Follower	Reel	Connect-ing Hose	Control Vlv. & Swivel
274886	274874 with bucket lid and follower	274874	274878	274888			
274887	274886 with hose reel, 50' hose, control valve, swivel & 7' connecting hose	274874	274878	274888	94553H	75084	3050, 81729

Accessories

Description	Model No.
10,000 psi Gauge	274872
35#/5-gal. Container Mount	274934



50Hz 380/420V 3 Phase AC FlowMaster Pump

The high-performance FlowMaster product line is a new generation of pump technology. Compact and versatile, its unique rotary drive and modular gear set let you adjust the pump to exactly fit your application.

- Wires directly to existing AC service
- Reduces installation costs – no need to tap into hydraulic circuits or pipe in compressed air
- Integrates easily to many styles of lubrication systems

Markets include:

- Heavy industry
 - Mining
 - Steel
 - Paper
- General Industry
 - Food/beverage
 - Automotive
 - Packaging
 - And others

Pump Model	85850	85851
Pump/Container Size	120 lb.	400 lb.
Pump Output	400 cm ³ /min. (24.5 in ³ /min.)	
Operating Temperature	-40° to 65°C (-40° to 150°F)	
Motor Max. Temperature	Up to 105°C (220°F)	
Operating Voltage	380/420 Volts 3 Phase	
Motor Power	1/2 Hp	
Pump Outlet	1/4" NPTF	

Accessories

Description	120 lb.	400 lb.
Follower plate	85492	270982
Drum cover	85474	85474
Vent valve assembly	85660	85661
Strainer	272180	272180



Model 84944

Model 84944

Hydraulic-operated pump with 60 lb. metal reservoir and vent valve.

Model:	84944	
Nominal Lubricant/ Hydraulic Pressure Ratio:	16:1	
Output/Min @ 30 Cycles/Min:	11 cu. in.	180 cc
Reservoir Capacity:	60 lb. / 27 kg	1800 cu. in. / 29,500 cc
Hydraulic Inlet/Outlet:	¼" NPTF (M)	
Lube Outlet:	¾" NPTF (M)	

Important Note:

1. Pumps require a timed electrical signal to operate. Use Model 244270 Cycle Timer. See System Controls section for specifications.
2. Included hydraulic solenoids require 24 VDC.

Model 84961

Basic pump only for Model 84944. Includes pump and hydraulic control. Does not include reservoir or vent valve.



Model 84960

Model 84960

Hydraulic pump for use with U.S. standard 120 lb. refinery drum. System components (pump, vent assembly, drum cover and follower plate) must be ordered separately.

Model 84962

Hydraulic pump for custom lubricant container installations. Pump length is sized for U.S. standard 400 lb. refinery drum depth.

Model	Nominal Lubricant/ Hydraulic Pressure Ratio	Output/Min @ 30 Cycles/Min	Lube Outlet	Pump Tube Length	Pump Tube Diameter
84960	16:1	11 in ³ / 180 cm ³	¼" NPTF(F)	—	—
84962				33 ¹ / ₁₆ " 862 mm	1" 25.4 mm

Important Note:

1. Pumps require a timed electrical signal to operate. Use Model 244270 Cycle Timer. See System Controls section for specifications.
2. Included hydraulic solenoids require 24 VDC.
Use Vent Assembly Model 84990; Drum Cover Model 84616 and Follower Plate Model 83371.
Drum Cover and Follower Plate are for use with Model 84960 only.



Model 84962

Hydraulic Power Supply Requirements

Hydraulic Inlet Pressure psig / bar		Flow Rate @ 30 Cycles/Min. GPM ltrs/min	Fluid Max. Inlet Temperature	Ambient Operating Temperature Range		Filtration Requirement
Min	Max			Min	Max	
300 / 21	3000 / 207	1.0 / 3.8	210°F/99°C	-40°F/-40°C	+135°F/57°C	10 Micron

Note: All pumps have a hydraulic pressure reducing valve rated for 60 psi (4 bar) to 800 psi (55 bar) output. Maximum input is 3000 psi (207 bar).

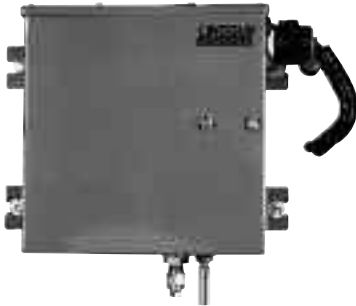

Model 85418



Controller

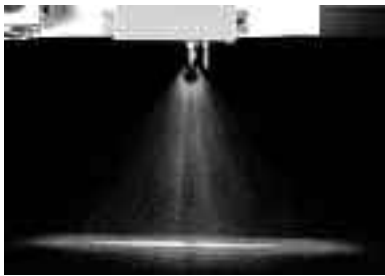

Model 85419



Model 84111

Airless Spray High-Pressure System

No air required—three words describe why Lincoln’s innovative new Airless Spray System is the only system of its kind on the market. But it takes many more words to list all the benefits the latest in Lincoln’s long line of technological advances has to offer. Because no air is required, the Airless Spray System means that mining, concrete, steel and other heavy industries can look forward to dependable, high-pressure lubricant spraying that’s low-maintenance and cost-effective.

85418 Airless Spray Valve

Model	Operating Voltage	Solenoid Valve Initial Current	Heater Current
85418	115 VAC	.18 Amps	1.80 Amps

Spray Tips

Model	Descrip.	Std Spray Tip	Std Tip with Swivel	Roto-Clean Tip	Roto-Clean Tip with Swivel*
252790	Retaining Nut	Required	Not Required	Not Required	Not Required
252792	Jet Stabilizer	Optional	Optional	Optional	Optional
85423-xxxx **	Std. Spray Tip	Required	Required	Not Required	Not Required
271579	Swivel Assy	Optional	Required	Optional	Required
252831	Body	Not Required	Not Required	Required	Required
85427-xxxx **	Roto-Clean Tip	Not Required	Not Required	Required	Required

* Discard tip retaining nut and protective cover, supplied with swivel assembly, when installing the roto-clean tip on a swivel assembly.

** See chart below for spray tip models

Standard Carbide Spray Tips	
Model	Model
85423-5001	85423-11003
85423-6501	85423-11004
85423-6502	85423-650067
85423-8001	85423-800067
85423-8002	85423-950080
85423-9501	85423-1100067
85423-9502	85423-1100080
85423-11001	

Roto-Clean Carbide Spray Tips	
Model	Model
85427-5001	85427-9501
85427-6501	85427-9502
85427-6502	85427-650067
85427-8001	85427-800067
85427-8002	85427-1100067

Pumps

Lincoln offers many pump options for supplying lubricant to the lube system. Air-operated pumps are preferred when possible due to their versatility and wide range of selection. Hydraulic and electric pumps are also available. **The pump must be capable of pumping the lubricant to a minimum of 3500 psi at the airless spray valve.**

Filters

Model	Description
85419	Dual filter panel with operator valve to select one of the two filters. The other filter is isolated from the system pressure for uninterrupted service and easy element replacement
84111	High-pressure, single in-line filter (recommended)
84004	Single in-line filter

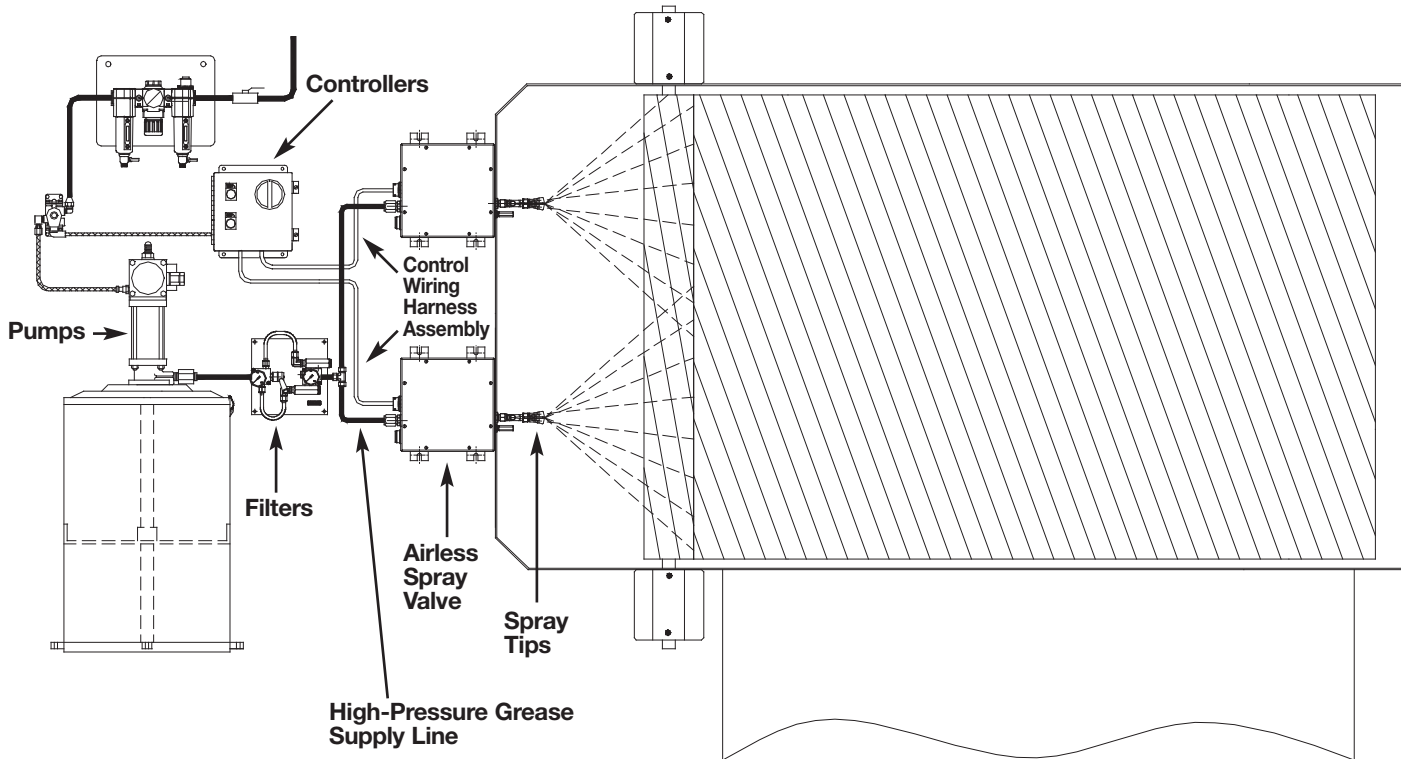

Controllers

Model	Description
254120	For single and dual Airless systems. Operates system by setting the time between lubrication events. Includes manual lube button and system alarm.
256228	For single Airless system with external initiate contacts with manual lube button and system alarm
254815	For dual Airless system with external initiate contacts with manual lube button and system alarm

Control Wiring Harness Assembly

Model	Description
256241	25' wiring harness connects the controller to each spray valve. One wiring assembly is required for each spray valve.

High Pressure Grease Supply Line

To be furnished by installer

2-Way Fluid Solenoid Valve

Model	Description
272285	For multiple machine/single pump applications. See design guide (form #403172) for details.



Reservoir Low-Level Alarm Kits

Low-level kits signal need to fill reservoir.

Model	Lubricant Type	Use with Models	Switch Type	Switch Capacity Voltage (Amps)	Features
83671	Grease	82653, 82655, 83668, 83800, 83834, 83167 83599, 1833, 1835, 1849 85434, 85435, 85436 85437, 85444, 85445	SPDT	125 VAC (15) 250 VAC (15) 480 VAC (15) 24 VDC (2) 125 VDC (½) 250 VDC (¼)	Connect to machine control or visual/audible alarm circuit.
83696	Oil	82570, 82573, 83667, 283167, 1848, 85430 85431, 85440, 85441			
84629	Grease	84960			Includes follower for U.S. Std. 120 lb. drum.
85490	Grease	84050	None	—	Includes follower, visual indication only.
249608	Grease	84050 new style			

Follower Plates

Recommended when pumping lubricants that do not readily seek their own level.



Model	Use with Pump Models	Container Size
83370	1827, 1829	Standard U.S. 400 lb. refinery drum
83371	1823, 282288, 84960	Standard U.S. 120 lb. refinery drum
92544	1828, 1830	Standard U.S. 120 lb. refinery drum
92597	84050, 84944	Lincoln 60 lb. container
252725	85483	Lincoln 35 lb. unit
85489	85481	Lincoln 60 lb. unit

In-Line Lubricant Filters

Filters mount in pump outlet before vent valve on reciprocating pump systems. Removes solid contaminants before delivering lubricants to the supply line.



Model 84004, 84523

Part No.	Element Size micron	Maximum Pressure	Connections in.	Hex Body Size - in.
84004	140	5000 psig / 340 bar	½ NPTF (M)	¼
84528	420			
*84239	10	6000 psig / 408 bar	¼ NPTF (F)	1¼

* In-line filter with Viton® seal.

Automatic Filling System Pressure Regulator

Pressurized systems automatically keep up to eight, single stroke oil pump reservoirs full at all times. Use with reservoir seal kits below. Fill pump not included.



Model	Fill Pump Requirements		Fill System Requirements			Lubricant Inlet/Outlet	Vent Outlet
	Max. * psig / bar	Max. Ratio	Max. Length		Reservoir Pressure psig / bar		
			5/8" Tube	3/8" Tube			
83372	125 / 8.6	3:1	100' / 30.5m	55' / 16.8m	5 / .34	½" NPT(F)	¼" NPTF(F)

* Indicates maximum lubricant output pressure.

Pressure Kits

Seal reservoirs for automatic filling.

Model	Use with Pump Models
83368	82885
83637	82570, 82573



Manual Filling Pumps

Designed to provide a fast, clean method of filling Centro-Matic pumps with a self-contained reservoir without the risk of lubricant contamination.

Model	Lubricant Type	Lubricant Output	Container Capacity	Hose Length	Lubricant Outlet	Dimensions - in. / mm		
						Height	Width	Container Diameter
81834	Grease NLGI #1 Max	1 oz/stroke 1.9 cu. in. 31 cc	30 lbs. 14.2 L	7' 2.1 m	645006 Hydraulic Coupler	26 3/4 679	14 356	9 229
1254	Oil	1 pint/ 7 strokes 473 cc	30 pints 14.2 L	5' 1.5 m	80599 Non-Drip Nozzle			



Metal Reservoirs: Rectangular reservoirs for gravity feed oil pumps

Standard 3/8" NPTF outlet furnished for gravity-fed pumps. Features spring loaded cap with strainer, sight gauge and Buna-N O-rings. Model 84376 Sight Gauge Kit available for use with synthetic oil.

Model	Capacity		Lubricant Outlet	Dimensions					
	Gal	Liter		Height		Width		Depth	
				in	mm	in	mm	in	mm
87417	5	19	3/8" NPTF (F)	10 1/8	257	17 1/2	446	12 1/2	318
87418	3	11.4				13 1/2	343	11 1/2	292
87419	1.5	5.7				10 1/2	267	7 1/2	191



Cylindrical Reservoir

Four-gallon steel tank-type reservoir consisting of Model 82700 tank and Model 82612 mounting brackets. Incorporates large filler opening with screw cap.

Model	Tank Number	Bracket Number	Capacity	Lubricant Outlet	Dimensions - in. / mm	
					Height	Diameter
82621	82700	82612	4 gal./15.1L	1/2" NPT (F)	18 / 457	9 / 229

Ultrasonic Sensor

Ultrasonic High/Low Sensor to make it easier to know when the 60 lb. Centro-Matic® automated lubrication system reservoir is getting low on lubricant and when it's refilled to capacity. Sensor detects the position of the follower plate with ultrasonic waves to report the lubricant level. The sensor is factory programmed for a 60 lb. reservoir. Its two outputs drive external signaling devices or connect with a customer's PLC. Three standard LEDs offer visual indication of the sensor's status and reservoir level.



Model	Description
270782	Ultrasonic sensor
270781	Ultrasonic sensor socket (required)

Ambient Temp. Range	Protection	Power Supply Operating Range	Current less load	Switching Outputs		
				Max. Current	High Level	Low Level
-13°F to 158°F -25°C to 70°C	IP65	20 - 30 VDC	60 mA	200 mA	NO contact (closes when full)	NO contact (opens when low)

Selecting the right controls for your automated lubrication system is one of the last steps in the design process. Several different models may be chosen to control power-operated pumps, depending on the degree of automation and monitoring required. Your Lincoln representative will assist you in specifying the correct model.

Options range from simple timers to fully-automated system controllers and monitors. Basic timers allow you to set the interval between lubrication cycles. More sophisticated monitors control the frequency of lubrication, oversee system performance and can sense lubricant flow to each bearing while showing system status and alarms on a LCD display panel. Monitors may be interfaced with machine control systems to protect your equipment from harm.

You may customize your installation with air and lubricant filters to prolong system life, pressure gauges for monitoring, shut-off valves to ease future maintenance and even automated filling systems to utilize bulk lubricant storage.

All of these possibilities, and more, have made Lincoln Automated Lubrication Systems the choice of industry for over 80 years.



Model 84501 Program Timer—Solid State

Designed to control the lubrication cycle frequency of air-operated single-stroke pumps. Timer turns pump on/off at programmed intervals via a 3-way or 4-way air solenoid valve (not included) installed in the air line to pump.

Off Time (Cycle Time)		On Time (Pumping Time)		Power Requirements	Approvals	Switch Capacity
Min	Max	Min	Max			
20 Sec.	24 Hrs.	10 Sec.	1 Min. 24 Sec.	120/230 VAC 50/60 Hz	UL, CSA	120 VAC, 5 Amps 230 VAC, 1.5 Amps

Built-In Program Options				Enclosure			Ambient Operating Temperature Range		
3 Hr. Program Memory		Prelube Function		Rating	Dimensions-in./mm			Minimum	Maximum
Yes	No	Yes	No		Height	Width	Depth		
Yes	No	Yes	No	NEMA #1	8¼ 210	6¼ 173	4¼ 125	0°F -18°C	130°F 54°C

Note:
Refer to Technical Manual for a full explanation of available program options.

Model 84511 Economy Timer for Single Stroke Pumps

Uses a timing motor, cam and switch to turn pump off and on. NEMA 1 enclosure, UL and CSA listed. Switch capacity 10 amps non-inductive.

Off Time (Cycle Time)		On Time (Pumping Time)		Power Requirements	Approvals	Switch Capacity
Min	Max	Min	Max			
5 Min.	1 Hr.	30 Sec.	90 Sec.	120 VAC, 60 Hz	UL, CSA	10 Amps

Note: Off-time selectable in 5 minute intervals.

Enclosure			
Rating	Dimensions - in. / mm		
	Height	Width	Depth
NEMA 1	5 / 127	3¼ / 82.5	3½ / 89



Model 84015 Timer—12-24V DC

Solid-state microprocessor-based controller for automated lubrication systems on mobile equipment or where AC power is not available. Rugged construction with liquid- and dust-tight enclosure. Includes manual push-button for remote initiation of a lube cycle.

Off Time** (Cycle Time)		Fixed On Time (Pumping Time)	Power Requirements	Switch Capacity
Min.	Max.			
2.5 Min.	80 Min.	75 Sec.	10-30 VDC 25 MA*	5 Amps

* Less load.

** Available selections are 2.5, 5, 10, 20, 40 or 80 minutes.

Rating	Enclosure			Ambient Operating Temperature Range	
	Dimensions-in. / mm			Minimum	Maximum
	Height	Width	Depth		
NEMA 12	5¼ / 133	3⅞ / 79	3 / 76	0°F / -18°C	131°F / 55°C



Model 85520 Programmable Controller

Microprocessor-controlled, 120 volt AC unit is fully programmable. Controller has a wider off-time range than timers and a memory switch to turn pre-lube option on or off.

Off Time (Cycle Time)		On Time (Pumping/ Alarm Time)		Power Requirements	Switch Capacity Inductive Load at 120VAC	
Min.	Max.	Min.	Max.		Load Relay	Alarm Relay
30 Sec.	30 Hours	30 Sec.	300 Sec.	120 VAC 50/60 Hz	2 Amps	2 Amps

Rating	Enclosure			Ambient Operating Temperature Range	
	Dimensions-in. / mm			Minimum	Maximum
	Height	Width	Depth		
NEMA 12	7½ / 191	4⅞ / 125	3½ / 89	0°F / -18°C	130°F / 55°C

* Less load.

Model 85525 Programmable Controller

Same as Model 85520 except includes pressure switch and mounting brackets.

Model 85535 System Controller—24V DC

Same as Model 85520 except is a 24-volt DC.



Model 85530 Lubrication System Controller

Controls lubrication frequency and monitors supply line pressure. The LCD displays operating status.

Lube Cycle				Max. Count Rate*	Pumping Time Before Alarm	
Timer Mode Off-Time		Counter Mode Off-Counts			Min.	Max.
Min.	Max.	Min.	Max.			
1 Minute	9,900 Minutes	1 Count	99,000 Counts	30/Sec. @ 50% Duty Cycle	1 Minute	99 Minutes

* Minimum duration of count signal is 33 milliseconds.

Power Requirements (less load)		Pump, Solenoid, or Alarm Capacity	Ambient Temperature Range	Rating	Enclosure		
Voltage	Current				Dimensions-in. / mm		
					Height	Width	Depth
120 VAC, 50/60 Hz	85 MA	360 VA	32° to 122°F 0° to +50° C	NEMA 12	9½ 241	8¼ 227	4¼ 105
230 VAC, 50/60 HZ	45 MA						
24 VDC	250 MA	5 Amps					

Note: Model 85530 is CSA/NRTL approved.



Model 85209 Panel Mounted Pneumatic Control System

Panel mounted units control lubrication frequency and monitor supply line pressure. Includes Model 85530 Controller (specifications above), Model 69630 Pressure Switch and solenoid-operated air valve.

Lube Cycle				Max. Count Rate	Pumping Time Before Alarm		Connections	
Timer Mode Off Time		Counter Mode Off Counts			Min.	Max.	Air	Lube
Min.	Max.	Min.	Max.					
1 Minute	9,900 Minutes	1 Count	99,000 Counts	30/Sec.	1 Minute	99 Minutes	¾" NPTF(F)	¾" NPTF(F)

Power Requirements		External Alarm Load Capacity	Ambient Temperature Range	Panel Dimensions in. / mm	
Voltage	Current (less load)			Height	Width
120 VAC, 60 Hz 110 VAC, 50 Hz	47 VA	360 VA	32° to 122°F 0° to +50°C	12 305	18¼ 464

Model 85208

Same as Model 85209 except 220 VAC, 50-60 Hz power.



Model 85500 System Sentry II

The ultimate automated lubrication system controller/monitor now features greater monitoring accuracy with less sensitivity to lubricant flow rates, feed line length, or bearing back pressure. System Sentry II is always on the job, making sure that every lube point is lubricated when it's supposed to be.

- Solid-state controller with LCD status display and 16-button keypad for system programming
- Controls up to two pumps with as many as two lube zones per pump
- Fully programmable monitoring and alarm functions
- Be set up to monitor every lube point for lubricant flow during each lubrication event
- Easy to understand prompts reported by simple English language messages in real time

Some functions require optional accessories. Use a maximum of 48 sensors and three accessory Sensor Boards (order separately—16 sensors per board) to monitor lube points.

Lube Cycle				Max. Count Rate*	Pumping Time Before Alarm		Net Wt.
Timer Mode Off-Time		Counter Mode Off-Counts			Min.	Max.	
Min.	Max.	Min.	Max.				
1 Second	9,900 Minutes	1 Count	99,000 Counts	30/Sec. @ 50% Duty Cycle	1 Second	99 Minutes	18 lbs. 8.1 kg

* Minimum duration of count signal is 33 milliseconds.

Power Requirements (less load)		Pump, Solenoid, or Alarm Capacity	Ambient Temperature Range	Rating	Enclosure		
Voltage	Current				Dimensions-in. / mm		
					Height	Width	Depth
120 VAC, 50/60 Hz	250 MA*	360 VA	32° to 122°F 0° to +50° C	NEMA 12	11 241	14 227	4 7/8 105
230 VAC, 50/60 HZ	125 MA*						
24 VDC	600 MA*	5 Amps					

Note: Model 85500 is CSA/NRTL approved.

* No external load, no sensors.



Model 247333 Pressure Transducer

Pressure Transducer signals actual system pressure via LCD display of System Sentry II. Comes with 72 inch (1.8m) shielded 24-gauge connecting wire. Maximum length of wire between transducer and monitor is 30 (9.1m) feet.

Range	Accuracy	Proof	Pressure Connection	Ambient Temp.	Input	Voltage Output	Offset	Enclosure
0 to 4000 psi 276 bar	±1%	7500 psig 517 bar	¼" NPT Male Thread	-20° to 180° F -29° to 82° C	10 to 30 VDC	1-6 VDC	1 VDC	NEMA 4X Rating 300 Series Stainless Steel

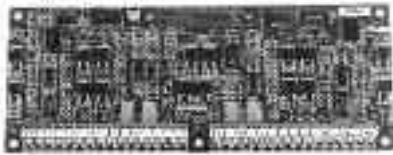

Model 250365 Sensor Board

Plug-in accessory board used with Model 85500 that allows the attachment of up to 16 lube flow sensors. (Model 85500 comes without boards installed and can hold up to a total of three.)



Sensor Assemblies

Sensor assemblies consist of a check body and lube sensor with attached 30' cable. Cables are epoxy potted into the sensors for a watertight seal. Sensors have a 3/8" pipe thread for conduit connection and a Viton® O-ring seal. Check bodies terminate in a 1/8" NPTF male thread for attachment to a bearing or other lubricant inlet. Maximum working pressure 6,000 psi (414 bar). Maximum wire run from sensor to monitor is 500 feet (152m).

Model	Description	Construction	Lubricant Temp. Range	Min. Flow Per Event	Inlet/Outlet	Min. Interval Between Lube Flow Event
250400	Straight Sensor Assembly	Brass Sensor & Plated Steel Check Body	32° to 145° F 0° to 63° C	.004 cu.in./ .066 cc @ 32°F / 0° C to 125°F / 52°C	1/8"	30 Seconds
250490	90° Sensor Assembly					
250500	Straight Sensor Assembly	316 Stainless Steel	.008 in³ / .131cc @ 126°F / 53°C to 145°F / 63°C			
250590	90° Sensor Assembly	Sensor & Check Body				

Model 243100 Sensor Wire

100 foot (30.5 meters) coil of two conductor 22-gauge wire for connecting sensors to monitor. Maximum length of wire between sensor and monitor is 500 feet (152 meters).



Use This Guide to Select Accessories for Model 85500 System Sentry II

Function	Pressure Switch #69630	Pressure Transducer #247333	Sensor Board #250365	Sensors Note 2	Sensor Wire #243100 (100') Note 3
Lube Controller 1 Pump, 1 Zone Note 1	Optional 1	Optional 1	—	—	—
Lube Controller, 1 Pump, 1 per Zone Up to 3 Zones	Required Required 1 (3 Max.)	—	—	—	—
Lube Controller, 2 Pumps, 1 Zone Per Pump	No	Required 2 (1 per Pump)	—	—	—
Lube Controller, 2 Pumps, Up to 2 Zones Per Pump	Required 1 per Zone (4 Max.)	Required 2 (1 per Pump)	—	—	—
Lube Point Monitoring ≤ 48 Points	—	—	Required 1 per each 16 Sensors	Required 1 per Lube Point	Required Quantity As Needed

Note 1: Controller may be operated without a pressure switch or pressure transducer but will not be able to monitor and alarm for lube system pressure failures.

Note 2: Sensors include 30' (9.1m) cable pigtail. Select brass/plated steel or stainless steel sensors in straight or 90° configuration as required.

Note 3: Maximum distance between monitor and sensor is 500' (152 meters).



Electric Solenoid-Operated Air Valves

Model	Type	Electrical Characteristics			Air Inlet/Outlet	Ambient Temperature Range	Cv Factor	Max. Pressure psi / bar	Conduit Connection
		Power Requirements	Inrush Current Amps	Holding Current Amps					
350244	4-Way	110 VAC, 50 Hz 120 VAC, 60 Hz 8.4 VA	.11	.07	¼" NPT(F)	0° to 120°F -18° to 49°C	1.2	150 10.3	½" NPS(F)
350245		220 VAC, 50 Hz 240 VAC, 60 Hz 8.4 VA	.055	.035					
350241	3-Way	110 VAC, 50 Hz 120 VAC, 60 Hz 8.4 VA	.11	.07	¼" NPT(F)	0° to 140°F -18° to 60°C	.18	150 10.3	N/A
350242		220 VAC, 50 Hz 240 VAC, 60 Hz 8.4 VA	.055	.035					
350282		12 VDC 6 Watts	N/A	N/A					
350283		24 VDC 6 Watts	N/A	N/A					
68586	2-Way	120V, 60 Hz 12 VA	.2	.1	¾" NPT(F)		2.4		½" NPT(F)
274398	3-Way	24 VDC 8.5 Watts	N/A	N/A	¼" NPT(F)		.5		N/A
244727	3-Way	110 VAC, 50 Hz 120 VAC, 60 Hz 11 VA	.12	.09	¾" NPT(F)	0° to 120°F -18° to 49°C	4.4		½" NPT(F)



Model 249605 Sealed Cycle Timer

Sealed timer attaches to Lincoln 16:1 Hydraulic Pumps and generates timed pulse signal to control pump reciprocating cycle rate.

Power Requirement	Cycle Rate/Minute	
	Min.	Max.
24 VDC	6	60



End-of-Line Monitors

Designed to detect system pressure utilizing normally open or normally closed switch.

Model	Switch Rating	Operating Range - psig / bar		Lube Inlet	Dimensions - in / mm		Conduit Connection
		Min.	Max.		Height	Width	
83898	125, 250 480 VAC,	1200 / 83	2500 / 172	1/4" NPT(F)	5 3/4 / 146	2 1/4 / 57	1/2" NPSM
83899	15 Amps	700 / 48	1150 / 79				



Model 83354 Signal Monitor

Designed to provide visual and audible indication of system operation and failure. Utilizes signal from system controller. Includes Model 69606 Alarm Horn mounted on enclosure door.

Power Requirement	Indicator Lamps			Audible Alarm	Dimensions - in / mm		
	Power On	Lube System On	System Failure		Height	Width	Depth
115 VAC 50/60 Hz 35 VA	Green	Amber	Red	69606 Horn (included)	10 254	8 203	6 152

Note: Lamps and horn are U.L. listed.



Model 69630 Pressure Switch

Senses supply line pressure rise/fall to signal system operation to controller or system alarm.

Type	Switch Capacity		Adjustable Range - psig / bar				Connections	
	AC	DC	Decreasing		Increasing		Lube	Electrical
			Min.	Max.	Min.	Max.		
Single Contact	10 Amps at 125, 250 or 480 VDC	15 Amps @ 6 VDC 5 Amps @ 24 VDC .03 Amps @ 250 VDC	250 17	2775 191	280 19	3000 207	1/4" NPT(F)	27/32" hole for 1/2" conduit connector

Note: Pressure switch has a NEMA 3 housing and UL listed switching elements.

Centro-Matic® Automated Lubrication Systems

Numerical Index



Viton® and Teflon® are registered trademarks of DuPont Performance Elastomers

Model No.	Page No.	Model No.	Page No.
P603S	20, 21	75084	34
P653S	18, 19	80072	19
525-32083-1	33	80073	19
645-41110-2	20	80074	19
645-41110-3	20	80075	19
645-41119-1	20	80076	19
645-41062-3	20	80077	19
645-41062-4	20	80078	19
645-41062-7	20	80079	19
645-41062-8	20	80080	19
645-41062-9	20	80081	19
645-41064-2	20	80082	19
645-41064-3	20	80083	19
645-41064-4	20	80084	19
645-41064-6	20	80085	19
645-41064-7	20	80086	19
645-41064-8	20	80087	19
645-41073-5	20	80088	19
1254	40	80089	19
1810	22	80090	19
1812	27	80091	19
1823	26, 39	80105	19
1826	30	80106	19
1827	26, 39	80107	19
1828	26, 39	80108	19
1829	26, 39	80109	19
1830	39	80110	19
1833	27, 39	80111	19
1835	27, 39	80112	19
1848	30, 39	80599	40
1849	27, 39	81646	16
2002	30	81675	30
2008	26	81713	9
2010	26	81713A	9
3050	34	81729	34
12511	17	81770-1	9
12511-9	17	81770-2	9
12698	17	81770-3	9
12698-9	17	81770-4	9
14988	16	81770-5	9
14991	16	81770-6	9
66260	17	81834	22, 24, 25, 27, 40
66260-9	17	82272	17
66713	17	82292	13
67007	17	82294-1	13
67007-9	17	82294-2	13
67044	17	82294-3	13
68421	17	82294-4	13
68483	16	82294-5	13
68586	47	82295	13
68587	17	82570	29, 39
68874	17	82573	29, 39
69456	17	82612	40
69630	43, 46, 47, 48	82621	40

Model No.	Page No.	Model No.	Page No.
82653	24, 39	83715-7	5
82655	24, 39	83724-1	6
82676	29	83724-2	6
82700	40	83724-3	6
82885	29 , 39	83724-4	6
82886	24	83730	16
83167	25 , 39	83748	14
83272	16	83749-1	14
83309-1	5	83749-2	14
83309-2	5	83749-3	14
83309-3	5	83749-4	14
83309-4	5	83749-5	14
83309-5	5	83800	24, 39
83309-6	5	83817	22
83311-1	11	83834	24, 39
83311-2	11	83898	48
83311-3	11	83899	48
83311-4	11	83900	5
83311-5	11	83900-9	5
83311-6	11	83924	17
83311-10	11	83924-9	17
83311-15	11	84004	37 , 39
83313	11	84015	42
83314	5	84034	26
83314-9	5	84048	11
83336-1	6	84050	31 , 39
83336-2	6	84110	12
83336-3	6	84111	37
83336-4	6	84195	16
83337	6	84200	16
83337-9	6	84203	16
83338	6	84204	17
83354	48	84239	39
83368	39	84297	47
83370	39	84376	40
83371	26, 36, 39	84428-1	11
83372	39	84428-2	11
83535	11	84428-3	11
83599	25 , 39	84428-4	11
83637	39	84428-5	11
83661-2	12	84428-6	11
83661-3	12	84428-10	11
83661-4	12	84428-15	11
83660	12	84429-1	12
83661-1	12	84429-2	12
83667	29 , 39	84429-3	12
83668	24, 39	84429-4	12
83671	39	84501	24, 29, 41
83696	39	84511	41
83715-1	5	84528	39
83715-2	5	84616	32, 36
83715-3	5	84629	39
83715-4	5	84776	9
83715-6	5	84944	36 , 39

Model No.	Page No.	Model No.	Page No.
84960	36, 39	85427-800067	37
84961	36	85427-1100067	37
84962	36	85430	28, 39
84990	32, 36	85431	28, 39
85208	43	85432	28
85209	26, 30, 43	85433	28
85215	26	85434	23, 39
85217	30	85435	23, 39
85218	26	85436	23, 39
85220	32	85437	39
85244	32	85438	28
85247	32	85440	28, 39
85351-1	15	85441	28, 39
85351-2	15	85442	23
85351-3	15	85444	23, 39
85351-4	15	85445	23, 39
85351-5	15	85460	31
85351-6	15	85471	33
85352-1	15	85472	33
85352-2	15	85473	33
85352-3	15	85474	33, 34, 35
85352-4	15	85475	33, 34
85352-5	15	85480	32
85352-6	15	85481	32, 39
85353-1	15	85482	32
85353-2	15	85483	32, 39
85353-3	15	85486	32
85353-4	15	85487	32
85391	29	85489	39
85418	37	85490	39
85419	37	85492	32, 33, 34, 35
85423-5001	37	85497	10
85423-6501	37	85500	44, 45, 46
85423-6502	37	85520	27, 30, 42
85423-8001	37	85525	42
85423-8002	37	85530	43
85423-9501	37	85535	42
85423-9502	37	85585	32
85423-11001	37	85586	32
85423-11003	37	85588	34
85423-11004	37	85589	34
85423-650067	37	85591	33
85423-800067	37	85610	32
85423-950080	37	85660	34, 35
85423-1100067	37	85661	34, 35
85423-1100080	37	85662	34
85427-5001	37	85663	34
85427-6501	37	85664	33
85427-6502	37	85665	33
85427-8001	37	85676	32
85427-8002	37	85677	32
85427-9501	37	85678	32
85427-9502	37	85770-1	7
85427-650067	37	85770-2	7

Model No.	Page No.
85770-3	7
85770-4	7
85770-5	7
85770-6	7
85771	7
85772	7
85780-5	8
85780-6	8
85780-1	8
85780-2	8
85780-3	8
85780-4	8
85781	8
85782	8
85785-1	8
85785-2	8
85785-3	8
85785-4	8
85785-5	8
85785-6	8
85785-7	8
85785-8	8
85785-9	8
85785-10	8
85850	35
85851	35
86258	32
86261	32
87417	40
87418	40
87419	40
90537	16
92544	39
92597	31, 39
94553H	34
102781	16
239351	9
239352	9
239353	9
239354	9
239355	9
243100	45 , 46
244270	36
244727	47
247333	45 , 46
249281	16 , 17
249282	16 , 17

Model No.	Page No.
249605	47
249608	39
250365	45 , 46
250400	45
250490	45
250500	45
250590	45
252725	39
252790	37
252792	37
252831	37
254120	38
254815	38
256228	38
256241	38
270781	40
270782	40
270982	32, 33, 34, 35
271579	37
271605	32
271606	32
272180	33, 34, 35
272285	38
273088	16
273089	16
274398	47
274824	16
274886	34
274887	34
274872	34
274873	34
274874	34
274878	34
274888	34
274934	34
274899	33
282288	26 , 39
283167	30 , 39
350241	47
350242	47
350244	24, 29, 47
350245	47
350282	47
350283	47
645006	22, 24, 25, 27, 40

A Complete Line of Lubrication Solutions and Industrial Pumping Products



Automated Lubrication



Our automated systems dispense measured amounts of lubricant at predetermined intervals. Systems include Helios® and Duo-Matic® two-line systems, Centro-Matic®, Modular Lube® and Quicklub® as well as ORSCO® precision oil lubrication. With our BearingSaver® program, we find the best automated solution for you from our wide range of systems for grease, fluid grease and oil.



General Lubrication

Sometimes a simple approach is the best solution. Our wide range of products includes smaller, self-contained automated lubricators and general lubrication equipment.

Lincoln has developed specialized pumps and pumping stations to handle the difficult job of transferring thick fluids. From the industry-best PileDriver III® and PowerMaster III® pumps and air motors to specialty pumps, controls and mounting accessories, Lincoln is the preferred pumping system for many tough applications.

Industrial Pumping



Lincoln's global distribution network is the best in the industry.

Whatever the service—evaluating your lubrication methods, installing a custom-engineered system, or supplying top-quality manual lubrication products—your Lincoln distributor makes certain you always get the very best value.

Systems House Distributors

Our systems house distributors offer the highest level of expertise available in the industry. They can custom design a system with the exact combination of Lincoln components you need. Then, they install the system in your plant with their knowledgeable technicians or work with your personnel to make sure the job is done correctly. Each distributor stocks a full inventory of pumps, metering devices, controllers, monitors and accessories. Each continues to meet our stringent requirements for product, systems and service knowledge. From Los Angeles to London, Boston to Bangkok, Lincoln's top-of-the-industry systems house distributors will be there when and where you need them.



**For the nearest
authorized Lincoln
sales and service
representative, call:**

Americas:

**St. Louis, Missouri
314.679.4200
Fax: 800.424.5359**

Europe/Africa:

**Walldorf, Germany
49.6227.33.0
Fax: 49.6227.33.259**

Asia/Pacific:

**Singapore
65.6588.0188
Fax: 65.6588.3438**



Lincoln Industrial Corp.
One Lincoln Way
St. Louis, MO 63120-1578

Phone 314.679.4200
Fax 314.679.4359
www.lincolnindustrial.com

Form 442832 (09/09)
© Copyright 2009
Printed in U.S.A.