



AH200W48V050V40AN

48V_{in} 40A_{out} 5V_{out} High Efficiency, Isolated Half Brick DC-DC Converter

Features

- Very high efficiency: 92%@20A, 91%@40A 48V_{in}, 25°C, 300LFM)
- Wide input voltage range (36 to 75Vdc)
- Total weight: 63g. (2.22oz.) Open-Frame Version; Max 85g. (2.99oz.) Metal-Plate Version
- Low profile, industry standard footprint and pinout: 2.3" x 2.4" x 0.4" (58.4mm x 61.0mm x 10.2mm)
- Adjustable output voltage (+10% / -20%)
- Input to Output Isolation at 2000Vdc, 10MΩ
- Fixed Frequency (300 KHz)
- Undervoltage Lockout (UVLO)
- Overcurrent protection
- Overtemperature protection
- Auto-restart after overcurrent shutdown
- Remote sense
- Remote ON/OFF
- Operating temperature -40/+100°C
- ISO 9001 Certified manufacturing processes
- Fully Safety Certified



Product Highlights

- The AH DC-DC Converter family is Ault's solution for next generation, cutting-edge board applications.
- The synchronous rectification topology uses MOSFET instead of Schottky diodes providing extreme reduction in heat generation, boosting efficiency, eliminating the need for a heat sink and increasing reliability.
- The low profile (0.4"), open frame construction allows smaller card pitch and improves ventilation.
- The fixed switching frequency provides predictable EMI characteristics.





AH200W 48V 5.0V High Efficiency DC-DC Converter

Mechanical Drawings

- All dimensions are in inches (mm)
- Tolerances: x.xx in. +/-0.2 in. (0.5mm)
- Pins 1-4, 6-8 are 0.040" (1.02mm) dia. with 0.080" (2.03mm) dia. standoff shoulders

OPEN-FRAME VERSION

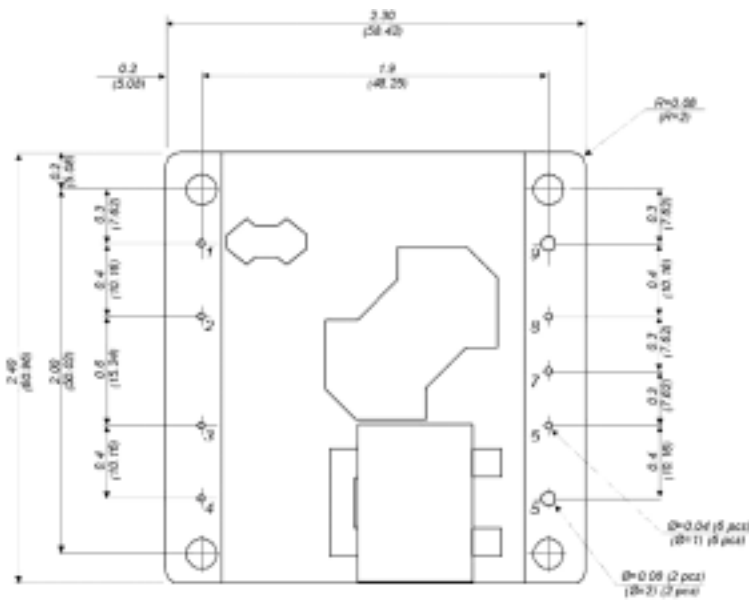

Bottom View



METAL-PLATE VERSION

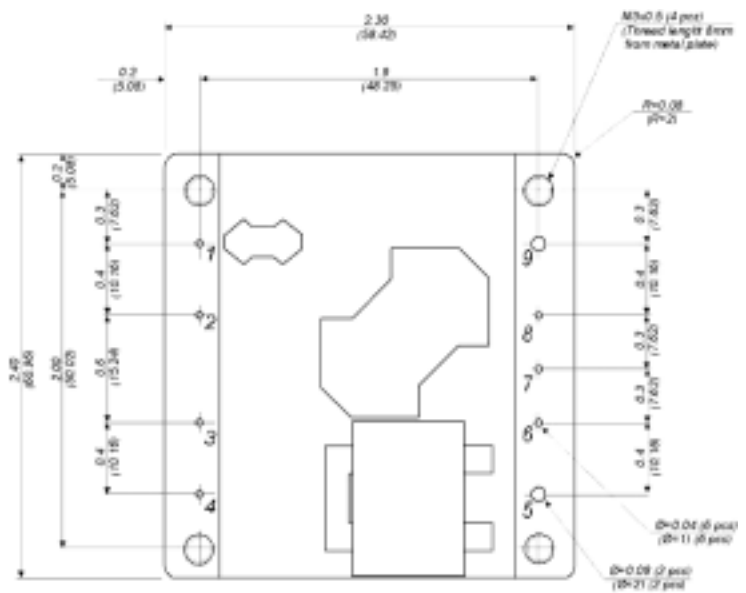

Bottom View

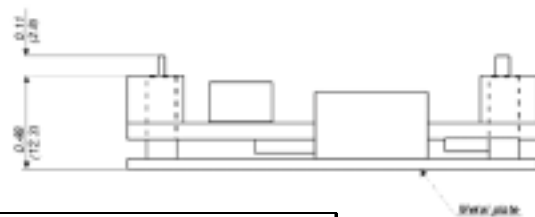

PINOUT Description		
Pin	Name	Function
1	Vin (-)	Return terminal for the -48V input bus
2	Not Present	
3	ON/OFF	Logic signal referenced to Vin (-), TTL compatible (internal pull up) to turn converter on and off
4	Vin (+)	Positive terminal for the +48V input bus
5	Vout (+)	Positive terminal for output voltage
6	Sense (+)	Positive remote sense
7	TRIM	Output voltage TRIM
8	Sense (-)	Negative remote sense
9	Vout (-)	Return terminal for output voltage



AH200W 48V 5.0V High Efficiency DC-DC Converter

Specifications

(Typical values are at nominal input line, full load, airflow 300 LFM, 25°C ambient temperature unless otherwise specified)

Input characteristics	Notes & Conditions	Min	Typ	Max	Units
Operating Input Voltage Range	Note 1	36	48	75	V
Input Surge Voltage	T < 10μs			100	V
Input Under-Voltage Lockout					
<i>Turn-On Voltage Threshold</i>		35.0	35.2	35.4	V
<i>Turn-Off Voltage Threshold</i>		31.7	31.9	32.1	V
<i>Lockout Hysteresis Voltage</i>		3.3	3.3	3.3	V
Maximum Input Current (I _{INmax})	V _{IN} =36V; Full Load at nominal output voltage			6.2	A
No-load Input Current			70	100	mA
Off Converter Input Current			8	10	mA
Inrush Current Transient Rating			0.03		A ² s
Input Reflected-Ripple Current	RMS; see figures 6,7		10	15	mA

Output characteristics	Notes & Conditions	Min	Typ	Max	Units
Output Voltage Set Point	50 % Load	4.98	5.00	5.02	V
Output Voltage Regulation					
<i>Over Load</i>			± 6	± 10	mV
<i>Over Line</i>			± 6	± 10	mV
<i>Over Temperature</i>			± 25	± 40	mV
Total Output Voltage Range		4.95		5.05	V
Output Voltage Ripple and Noise	20 MHz bandwidth				
<i>Peak to Peak</i>	Full load, 2x10μF ceramic; see fig. 6, 8		80		mV
<i>RMS</i>			18		mV
Operating Output Current Range		0	-	40	A
Output DC Current Limit Inception	Output Voltage 10% low	42	45	48	A
Output DC Current Limit Shutdown Voltage	See figure 5		2.3		V
Admissible Output Capacitance	Full load, resistive	0		40000	μF

Dynamic characteristics	Notes & Conditions	Min	Typ	Max	Units
Output Voltage Current Transient	470μF load cap. 1A/μs; see figure 3				
<i>Positive Step Change in I_{OUT}</i>	50% to 75% load		150		mV
<i>Negative Step Change in I_{OUT}</i>	75% to 50% load		150		mV
<i>Settling Time to 1%</i>			100		μs
Turn On Transient	See figures 1, 2				
<i>Turn On Time</i>	Full load		4		ms
<i>Output Voltage Overshoot</i>	10mF load capacitance, I _{out} = 0A		0		%

Efficiency	Notes & Conditions	Min	Typ	Max	Units
Load 100%	V _{in} =50V	90.5	91		%
Load 75%	V _{in} =50V	91.5	92		%
Load 50%	V _{in} =50V	91.5	92		%

NOTE 1 : Absolute max. input voltage 80V



AH200W 48V 5.0V High Efficiency DC-DC Converter

Isolation characteristics		Notes & Conditions	Min	Typ	Max	Units
	Isolation Voltage input to output	Basic isolation	2000			V _{DC}
	Isolation Voltage Input to plate	Basic isolation	2000			V _{DC}
	Isolation Capacitance			3300		pF
	Isolation Resistance		10			MΩ

General characteristics		Notes & Conditions	Min	Typ	Max	Units
	Operating Range Temperature	Maximum Rating	-40		+100	°C
	Storage Temperature	Maximum Rating	-50		+120	°C
	Relative Humidity	Non condensing	5		95	%
	Calculated MTBF	Bellcore Issue 4 RDF93 HRD Issue 5	1,965,099 hours			
	Approvals		EN60950; UL & CSA 60950 & IEC 60950. CE to LVD			

Feature characteristics		Min.	Typ.	Max	Units
	Switching frequency		300		kHz
	ON/OFF Control				
	<i>Off-State Voltage</i>	2.7		15	V
	<i>On-State Voltage</i>	0		0.8	V
	Output Voltage Trim Range	-20		+10	%
	Output Over-Voltage Protection			130	%
	Over-Temperature shutdown	PCB Hot spot	125		°C



AH200W 48V 5.0V High Efficiency DC-DC Converter

Performance Curves

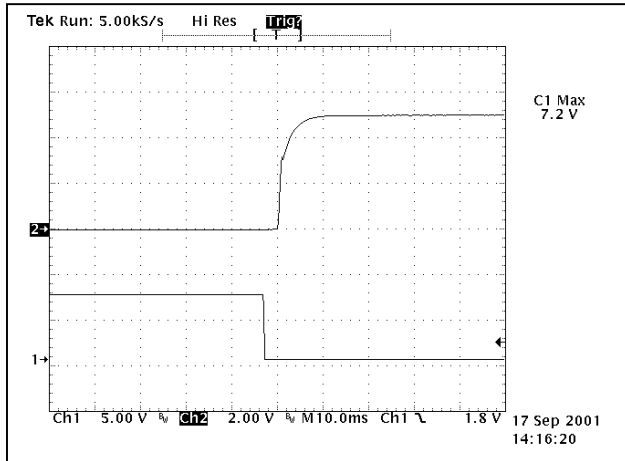

Figure 1. Turn-on transient at full rated current (resistive load)
Top Trace: Vout; 2V/div (Vin=50V)
Bottom Trace: ON/OFF; 5V/div

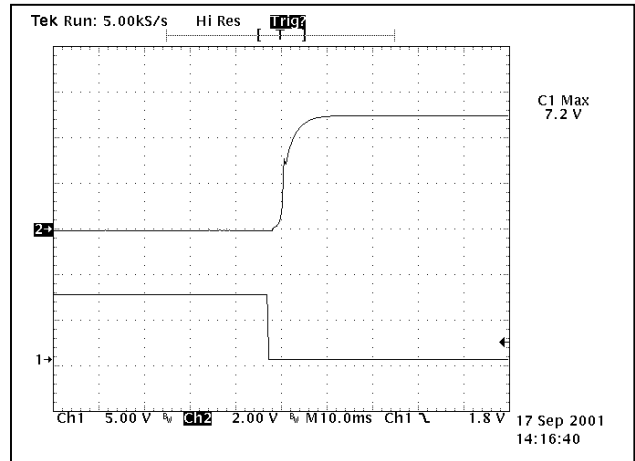

Figure 2. Turn-on transient at zero load.
Top Trace: Vout; 2V/div (Vin=50V)
Bottom Trace: ON/OFF; 5V/div

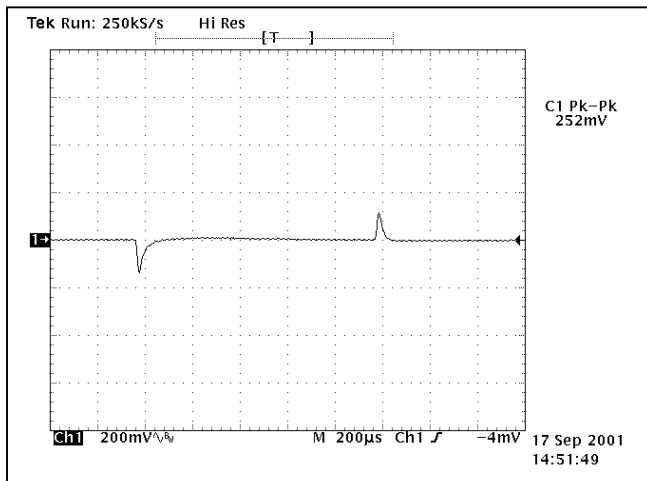

Figure 3. Output Voltage response (200mV/div) to a step-change in load current (50% - 75% - 50% of $I_{max}:dl/dt=1A/\mu s$.
Load capacitance: 470 μ F, 30mOhm ESR tantalum capacitor .

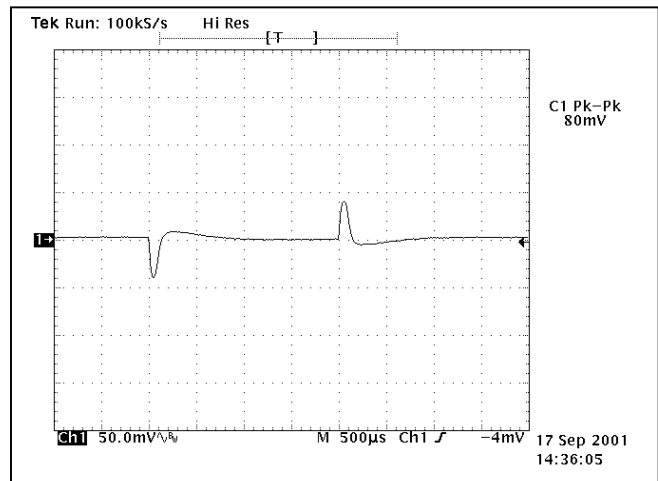

Figure 4. Output Voltage response (50mV/div) to a step-change in load current (50% - 75% - 50% of $I_{max}:dl/dt=0.1A/\mu s$.
Load capacitance: 470 μ F, 100mOhm ESR tantalum capacitor .

AH200W 48V 5.0V High Efficiency DC-DC Converter

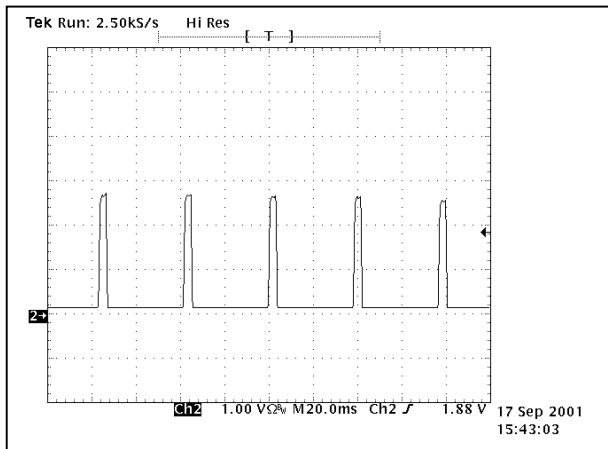

Figure 5. Load current (0.5A/div) vs time when converter attempts to turn on into 10mOhm short circuit.

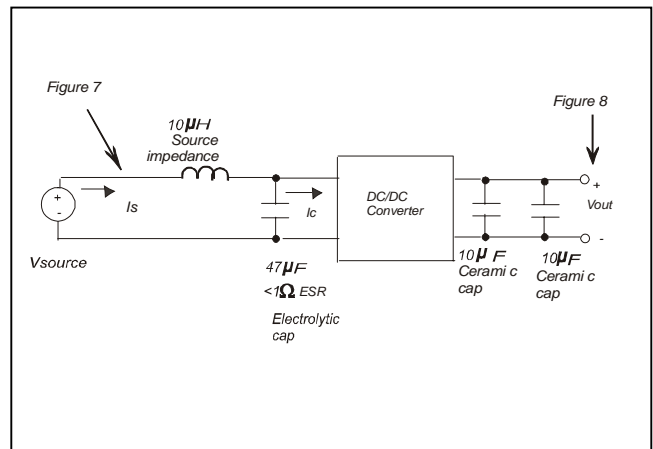

Figure 6. Test set-up diagram showing measurement point for Input Reflected Ripple Current and Output Voltage

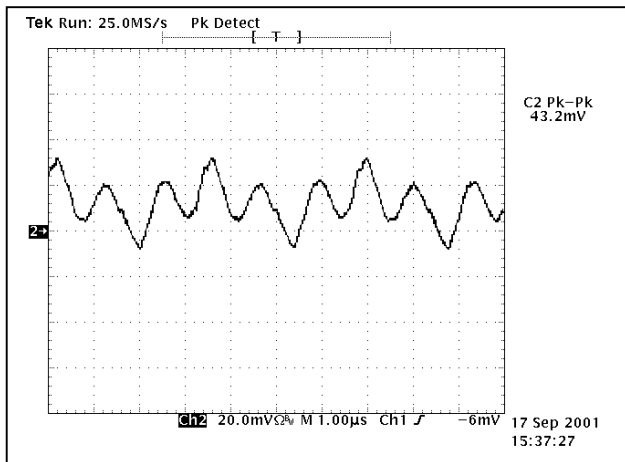

Figure 7. Input reflected ripple current at nominal input voltage and rated load current (see Fig.6)

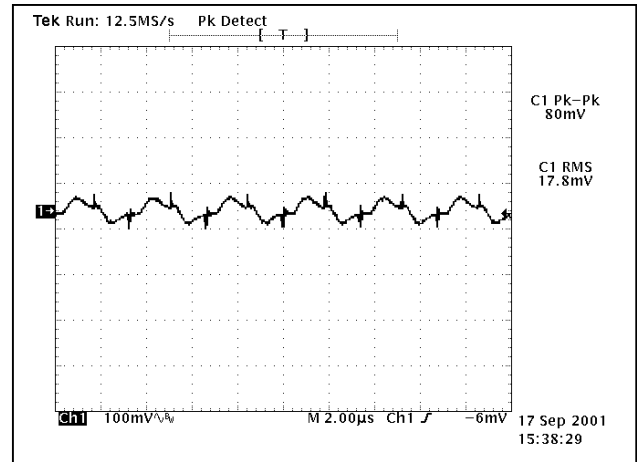

Figure 8. Output voltage ripple at nominal input voltage and rated load current. Load cap: 20µF ceramic capacitor
** see note below (see Fig.6)

** Output ripple measure: care must be taken to insert the output capacitors in the output current paths. The measurements is taken with the following output capacitors:
 -2x AVX PN CM316X5R106K006AT
 -2x Murata PN GRM31CR60J106KC01L
 -2x Taiyo Yuden PN JMK316B106KL

AH200W 48V 5.0V High Efficiency DC-DC Converter

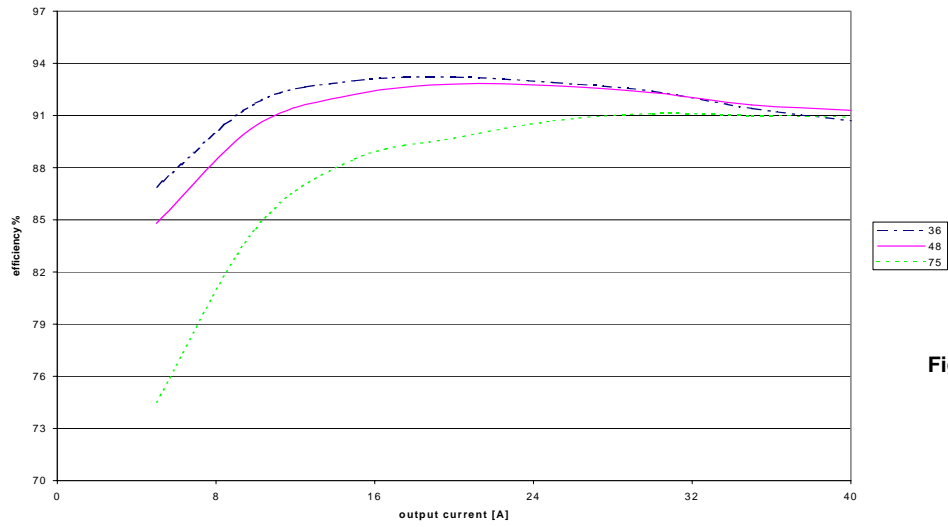

Figure 9. Efficiency vs. load current for minimum, nominal and maximum input voltage.

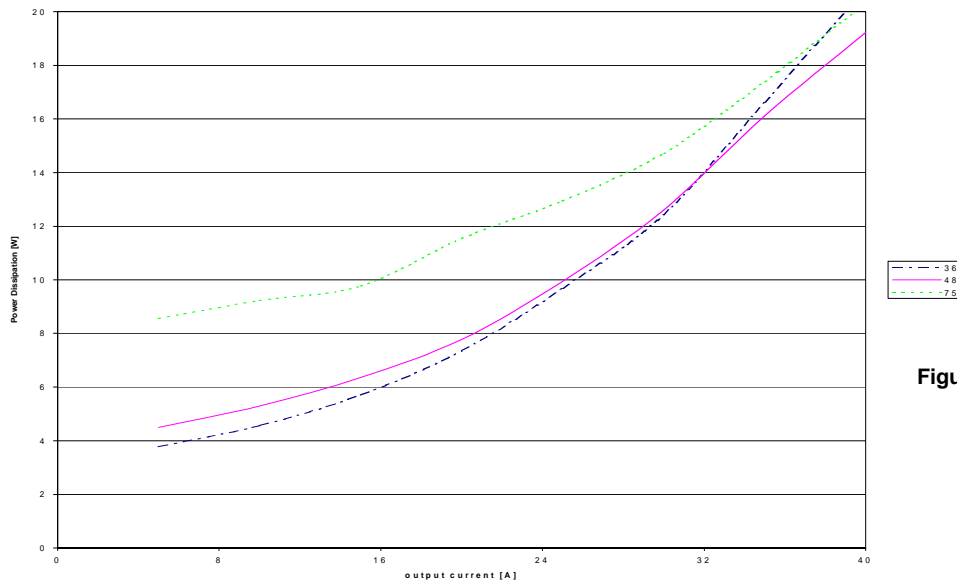

Figure 10. Power dissipation vs. load current for minimum, nominal and maximum input voltage.

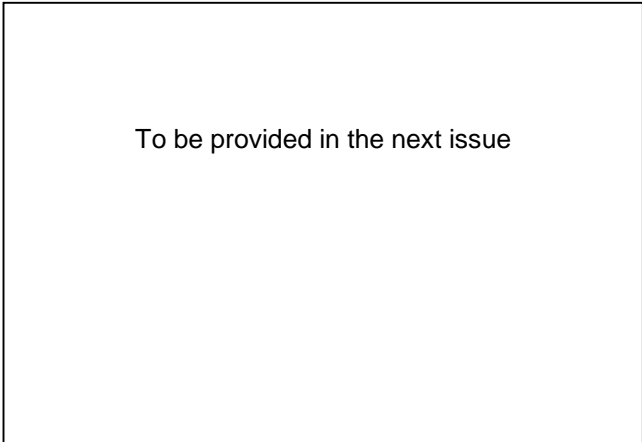

Figure 11: Maximum output power derating curves vs. ambient air temperature for airflow rates of 0 LFM through 400 LFM with air flowing from **input to output** and nominal input voltage.

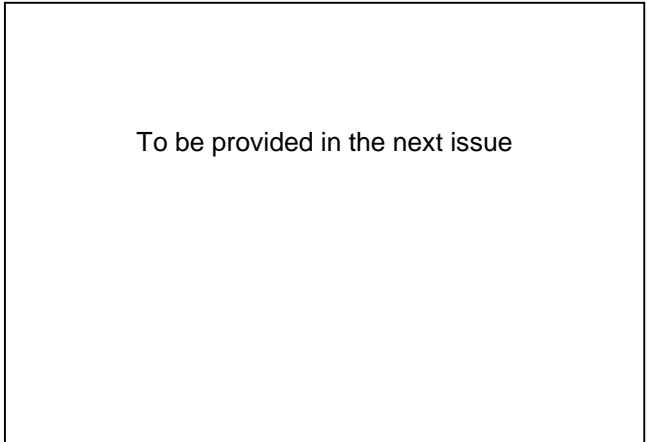

Figure 12: Thermal plot of converter at 30 amp load current with 40°C air flowing at the rate of 300 LFM. Converter in vertical position with air flowing from **input to output**.

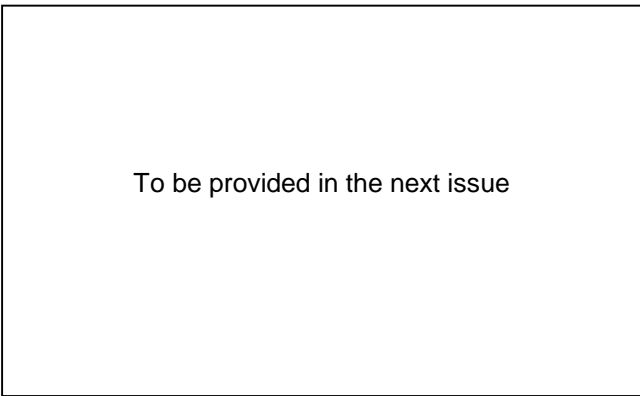

Figure 13: Maximum output power derating curves vs. ambient air temperature for airflow rates of 0 LFM through 400 LFM with air flowing from **output to input** and nominal input voltage.

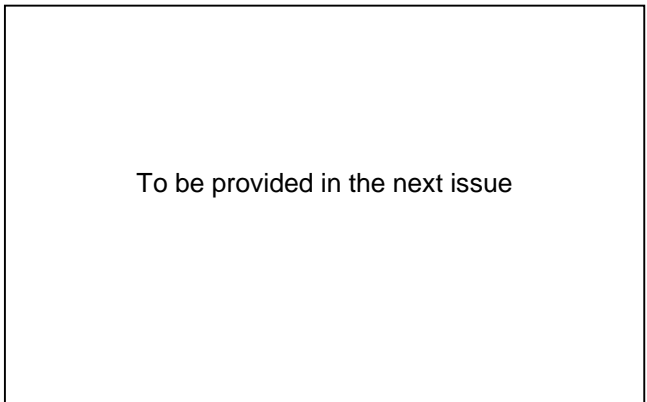

Figure 14: Thermal plot of converter at 30 amp load current with 40°C air flowing at the rate of 300 LFM. Converter in vertical position with air flowing from **output to input**.



AH200W 48V 5.0V High Efficiency DC-DC Converter

Features and Pins description

SAFETY

The converter is certified according to EN60950, UL and CSA 60950, 3rd ed., and IEC 60950. The converter has basic insulation rating. The converter meets NEBS compatibility. An external input fuse must always be used.

ON-OFF CONTROL

The default logic is negative: the on/off (pin #2) voltage is referenced to the -Vin (pin #4) and must be lower than 0.8V to turn the module on, and higher than 2.7V to shut the module off. Consult the factory for availability of positive logic modules.

TRIMMING

The output voltage can be trimmed by means of an external resistor connected between the Trim and the +S or -S pins. The selection of the resistor follows the industry standard.

A resistor connected between Trim and -S pins will decrease the output voltage. For a decrease of Δ% of the nominal output voltage, the value of the resistor should be:

$$R_{\text{trim-down}} = \left(\frac{100\%}{\Delta} \right) - 2k\Omega, \quad \text{where } \Delta = \left(\frac{V_{\text{nominal}} - V_{\text{target}}}{V_{\text{nominal}}} \right) \times 100\%$$

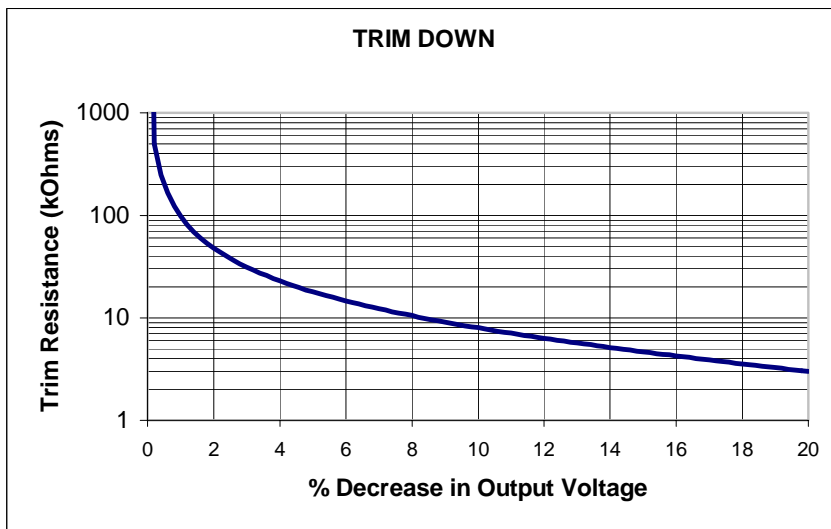

Figure A

A resistor connected between Trim and +S pins will increase the output voltage. For a desired increase of Δ% of the nominal output voltage, the value of the resistor should be:

$$R_{\text{trim-up}} = \frac{\left(\frac{V_{\text{nom}}}{V_{\text{ref}}} - 2 \right) \cdot V_{\text{tar}} + V_{\text{nom}}}{V_{\text{tar}} - V_{\text{nom}}} k\Omega, \quad \text{where } V_{\text{nom}} = \text{Nominal Voltage}, V_{\text{tar}} = \text{Target Voltage}, V_{\text{ref}} = 1.225 \text{ V}$$



AH200W 48V 5.0V High Efficiency DC-DC Converter

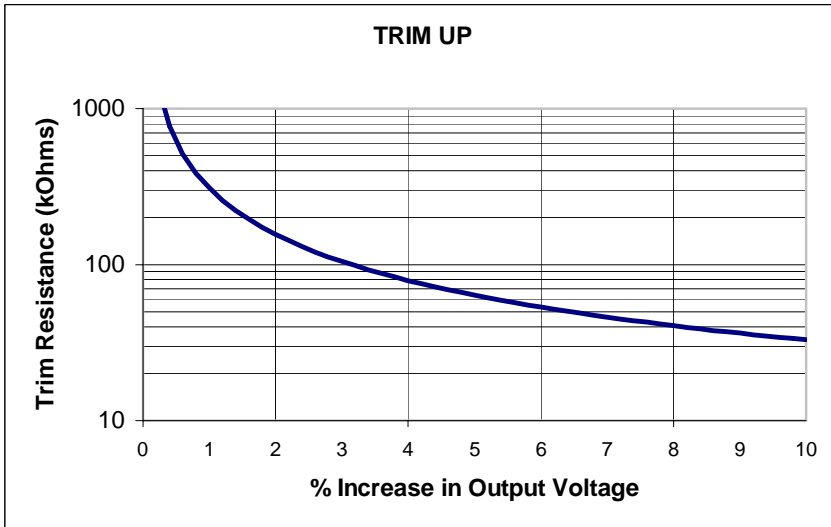

Figure B

SENSE (+ or -)

The + or - S pins should be connected to the load to have a tight regulation.

The maximum voltage drop that can be compensated for is 10% of V_{out} .

Note that the overvoltage protection senses the output voltage directly at + V_{out} and - V_{out} pins.

Care must be taken to avoid that the voltage at the output terminals + V_{out} and - V_{out} pins exceeds 5.5.

THERMAL CONSIDERATIONS

The module is provided with thermal protection that prevents the hot spot on the PCB from exceeding 125°C.

Depending on the air flow rate and the ambient temperature the maximum current reachable when the thermal protection kicks in is shown in Figure 11-12-13-14.

OVERCURRENT PROTECTION

The overcurrent limit inception is typically at 110% of the rated output current. When this limit is exceeded the output voltage decreases.

A further current increase will trigger the hiccup protection.

The behavior of the converter when the output is short circuited is shown in Figure 5.

Ault Incorporated
7105 Northland Terrace

Phone: 1-800-635-3311

763-592-1900

Fax: 7630592-1911

Website: <http://www.aultinc.com>