

AHP-1152

15" XGA HMI Touch Panel Computer With Onboard Intel® Atom™ D510 1.66 GHz Processor

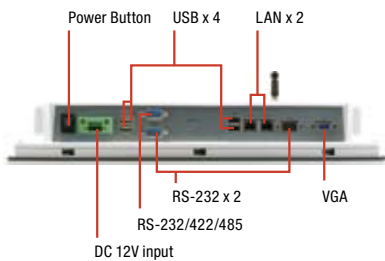

Features

- Onboard Intel® Atom™ D510 1.66 GHz
- 15" 250 Nits XGA CCFL Backlight
15" 800 Nits XGA LED Backlight
- Fanless Operation
- Slim Design: 65mm
- WiFi (Optional)



Specifications

| System | |
|-------------------------|--|
| Processor | Intel® Atom™ D510, 1.66 GHz |
| System Memory | DDR2 SODIMM, Up to 2 GB |
| LCD/CRT Controller | Integrated in Processor, shared memory up to 224MB |
| Ethernet | 10/100/1000Base-TX, RJ-45 x 2 |
| I/O Port | USB2.0 x 4, RS-232 x 2, RS-232/422/485 x 1, LAN x 2, VGA x 1 |
| Storage Disk Drive | 2.5" SATA Hard Disk Drive /CompactFlash™ Slot (Internal) |
| Expansion Slot | Mini card x 2 |
| OS support | Windows® CE 6.0, Windows® XP Embedded, Windows® XP, Windows® 7, Windows® Embedded Standard 7, Linux Fedora |
| Mechanical | |
| Construction | IP-65 certified plastic front panel Plastic Gray panel |
| Color | PMS 5425C + Gray |
| Mounting | VESA 100/ Panel |
| Dimension | 16"(W) x 12.2"(H) x 2.6"(D) (407mm x 310.5mm x 65mm) |
| Carton Dimension | 20.67"(W) x 18.31"(H) x 9.1"(D) (525mm x 465mm x 230mm) |
| Gross Weight | 11.9 lb (5.4 kg) |
| Net Weight | 9.7 lb (4.4 kg) |
| Environmental | |
| Operating Temperature | 32°F ~ 122°F (0°C ~ 50°C) |
| Storage Temperature | -4°F ~ 140°F (-20°C ~ 60°C) |
| Storage Humidity | 5%~90% @ 40°C; non-condensing |
| Vibration | 3 g rms/ 5~ 500Hz/ operation – With HDD |
| Shock | 20 G peak acceleration (11 msec. duration) |
| EMC | CE/FCC class A |
| Power Supply | |
| DC input | DC 12V w/ 3-pin terminal block |
| LCD | |
| Display Type | 15" TFT-LCD |
| Max Resolution | 1024 x 768 |
| Max. Colors | 16.2M colors |
| Luminance | HTT: 250 cd/m ² , STT: 800 cd/m ² |
| Viewing Angle | HTT: 170°(H), 160°(V)/ STT: 160°(H), 140°(V) |
| Back Light | HTT: CCFL/ STT: LED |
| Back Light MTBF (hours) | HTT: 30,000/ STT: 60,000 |
| Touchscreen | |
| Type | 5-wire, Analog Resistive |
| Resolution | 2048 x 2048 |
| Light Transmission | >80% |
| Life time | 35 Million activations |

AHP-1152

Dimension

Unit: mm

Cutout Size: 394mm x 297,5mm

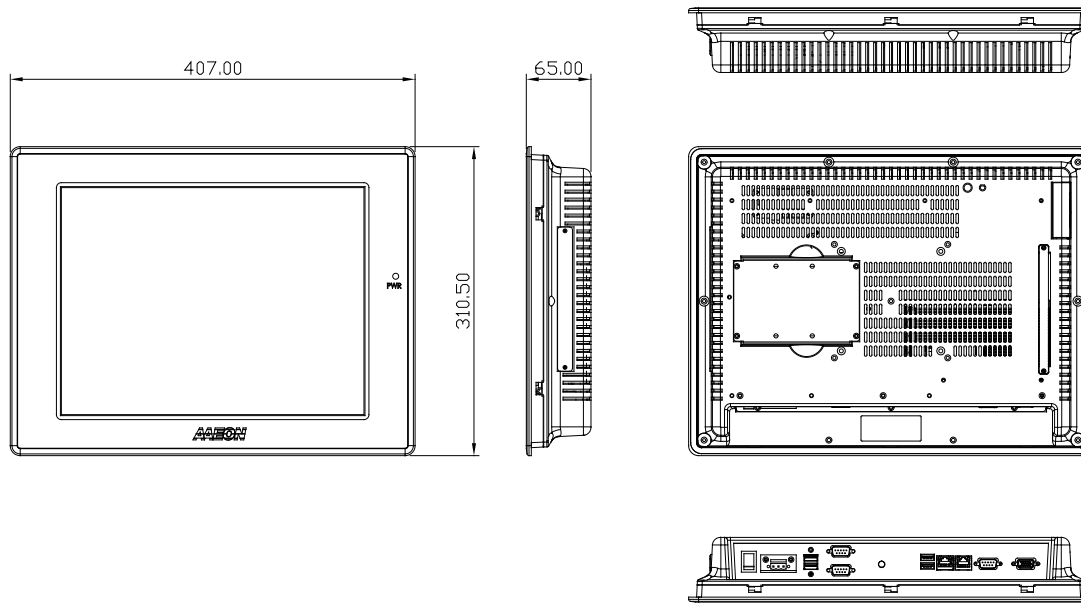

Ordering Information

| Part Number | Display Type | Max Resolution | Luminance | View Angle | Backlight MTBF (Hours) | CPU | LAN | USB | RS-232 | RS-485/422/232 | Storage | RAM | Display | Expansion | Mounting | Power | Temp. | Touch |
|------------------------|--------------|----------------|-----------------------|----------------|------------------------|-----------------------------|-----|-----|--------|----------------|--------------------------------|-------------|---------|---------------|------------------|-------|--------------------|------------------|
| TF-AHP-1152HTT-A1-1010 | 15" TFT-LCD | 1024 x 768 | 250 cd/m ² | 170(H), 160(V) | 30,000 | Intel® Atom™ D510 - 1.66GHz | 2 | 4 | 2 | 1 | CF kit x 1 SATA-HDD kit x 1 | 1G included | VGA x 1 | Mini Card x 2 | VESA 100 / Panel | DC12V | 0°C~50°C (w/o air) | 5-wire resistive |
| TF-AHP-1152STT-A1-1010 | 15" TFT-LCD | 1024 x 768 | 800 cd/m ² | 160(H), 140(V) | 60,000 | Intel® Atom™ D510 - 1.66GHz | 2 | 4 | 2 | 1 | CF kit x 1 SATA-HDD kit x 1 | 1G included | VGA x 1 | Mini Card x 2 | VESA 100 / Panel | DC12V | 0°C~50°C (w/o air) | 5-wire resistive |

Packing List

- Phoenix Power Connector
- Mounting Brackets and Screws
- CD-ROM for Manual (in PDF Format) and Drivers
- AHP-1152

Optional Accessories

- **STAND-8150B0**
Desktop Stand with VESA 100mm Standard
- **1702031802**
Power Cord (US Type)
- **1702031803**
Power Cord (European Type)
- **1757908401**
12V 84W Power Adapter w/ 3-pin Terminal Block
- **9761215303**
Wireless b/g/n