



**MODEL 9308**

Lock-In/Lock-Out

**MODEL 9307**

Lock-Out

Extra Heavy-Duty, Full Extension  
Up to 500 lb. [227 kg.] Load Rating  
Optional Accessory Platform Brackets

**APPLICATIONS:** Designed for use in heavy-duty mobile and vehicular applications where a lock-in and lock-out are required. **This product is covered by U.S. and various foreign patents issued and/or pending.**

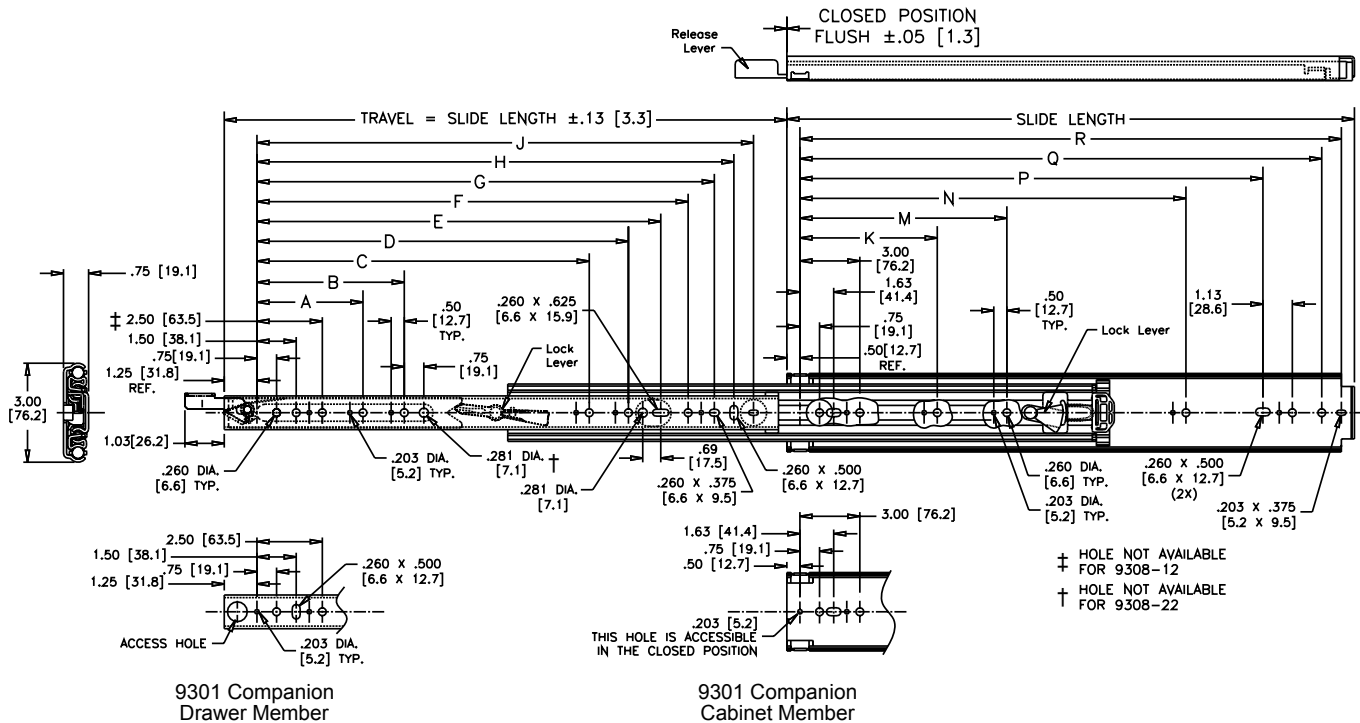

- Finish** Clear electroplate (C) only
- Length** Even lengths: 12"-32" [304.8mm - 812.8mm]
- Travel** Full extension
- Height** 3.00" [76.2mm]
- Side Space** .75" (+.031, -.000) [19.1mm (+.79, -.00)]
- Movement** Steel ball bearings
- Load Rating**
  - Moderate Use - 500 lbs. [227.3 kg.]
  - Frequent Use - 400 lbs. [181.8 kg.]
  - Mobile (Vehicular) - 300 lbs. [136.4 kg.]
  - See 9301 data sheet for further load information.

- Mounting** Side mount **Only** (Optional Accessory platform brackets available)
- Features** Non-disconnect. 9308 - Lock-in & lock-out. 9307 - lock-out only. Bumper provides extra silencing during drawer closure.
- Companion** 9301 non-locking slide can be used in conjunction with locking 9307 or 9308 (see 9301 datasheet)
- Hardware** Customer supplied (see back page)

**Caution** This slide must never be used as a pull-out step, platform or any other application supporting human weight as injury may result.

| Part Number | Slide Length     | Slide Travel     | A               | B               | C | D | E                | F                | G                | H                | J   | K               | M | N                | P                | Q                | R                |
|-------------|------------------|------------------|-----------------|-----------------|---|---|------------------|------------------|------------------|------------------|-----|-----------------|---|------------------|------------------|------------------|------------------|
| 9308-12     | 12.00<br>[304.8] | 12.00<br>[304.8] |                 |                 |   |   |                  | 6.06<br>[153.9]  | 7.06<br>[179.3]  | 7.81<br>[198.4]  |     |                 |   |                  | 8.00<br>[203.2]  | 10.25<br>[260.4] | 11.00<br>[279.4] |
| 9308-14     | 14.00<br>[355.6] | 14.00<br>[355.6] |                 |                 |   |   |                  | 8.06<br>[204.7]  | 9.06<br>[230.1]  | 9.81<br>[249.2]  |     |                 |   |                  | 10.00<br>[254.0] | 12.25<br>[311.2] | 13.00<br>[330.2] |
| 9308-16     | 16.00<br>[406.4] | 16.00<br>[406.4] |                 |                 |   |   |                  | 10.06<br>[255.5] | 11.06<br>[280.9] | 11.81<br>[299.9] |     |                 |   |                  | 12.00<br>[304.8] | 14.25<br>[361.9] | 15.00<br>[381.0] |
| 9308-18     | 18.00<br>[457.2] | 18.00<br>[457.2] | 5.00<br>[127.0] |                 |   |   |                  | 12.06<br>[306.3] | 13.06<br>[331.7] | 13.81<br>[350.8] |     |                 |   |                  | 14.00<br>[355.6] | 16.25<br>[412.8] | 17.00<br>[431.8] |
| 9308-20     | 20.00<br>[508.0] | 20.00<br>[508.0] | 5.00<br>[127.0] |                 |   |   | 11.69<br>[296.9] | 14.06<br>[357.1] | 15.06<br>[382.5] | 15.81<br>[401.6] |     |                 |   |                  | 16.00<br>[406.4] | 18.25<br>[463.6] | 19.00<br>[482.6] |
| 9308-22     | 22.00<br>[558.8] | 22.00<br>[558.8] | 5.00<br>[127.0] | 7.50<br>[190.5] |   |   | 13.69<br>[347.7] | 16.06<br>[407.9] | 17.06<br>[433.3] | 17.81<br>[452.4] | N/A |                 |   |                  | 18.00<br>[457.2] | 20.25<br>[514.4] | 21.00<br>[533.4] |
| 9308-24     | 24.00<br>[609.6] | 24.00<br>[609.6] | 5.00<br>[127.0] | 7.50<br>[190.5] |   |   | 15.69<br>[398.5] | 18.06<br>[458.7] | 19.06<br>[484.1] | 19.81<br>[503.2] |     |                 |   |                  | 20.00<br>[508.0] | 22.25<br>[565.2] | 23.00<br>[584.2] |
| 9308-26     | 26.00<br>[660.4] | 26.00<br>[660.4] | 5.00<br>[127.0] | 7.50<br>[190.5] |   |   | 17.69<br>[449.3] | 20.06<br>[509.5] | 21.06<br>[534.9] | 21.81<br>[553.9] |     |                 |   |                  | 22.00<br>[558.8] | 24.25<br>[615.9] | 25.00<br>[635.0] |
| 9308-28     | 28.00<br>[711.2] | 28.00<br>[711.2] | 5.00<br>[127.0] | 7.50<br>[190.5] |   |   | 19.69<br>[500.1] | 22.06<br>[560.3] | 23.06<br>[585.7] | 23.81<br>[604.8] |     |                 |   |                  | 24.00<br>[609.6] | 26.25<br>[666.8] | 27.00<br>[685.8] |
| 9308-30     | 30.00<br>[762.0] | 30.00<br>[762.0] | 5.00<br>[127.0] | 7.50<br>[190.5] |   |   | 21.69<br>[550.9] | 24.06<br>[611.1] | 25.06<br>[636.5] | 25.81<br>[655.6] |     | 9.25<br>[234.9] |   | 19.75<br>[501.6] | 26.00<br>[660.4] | 28.25<br>[717.6] | 29.00<br>[736.6] |
| 9308-32     | 32.00<br>[812.8] | 32.00<br>[812.8] | 5.00<br>[127.0] | 7.50<br>[190.5] |   |   | 26.06<br>[661.9] | 27.06<br>[687.3] | 27.81<br>[706.4] |                  |     | 9.25<br>[234.9] |   | 19.75<br>[501.6] | 28.00<br>[711.2] | 30.25<br>[768.4] | 31.00<br>[787.4] |

\* Load rating based on 18" slides side mounted in a 32" wide drawer.

## Mounting Instructions

1. With the slides fully extended, install cabinet member (outer member) with customer supplied 1/4" hex-head or pan head [M6 Euro] screws through the horizontal slots. Be sure slides are parallel.
2. Attach drawer to extended inner member with customer supplied 1/4" hex-head or pan head [M6 Euro] screws through the mounting holes/slots. Leave all screws loose for final adjustment. Adjust slide position until movement is smooth.
3. Tighten all screws and if necessary, use more screws to secure slides and complete installation. See Figure 1.

## Customer Supplied Mounting Hardware

**Metal Applications:** 1/4" hex-head or pan head [M6 Euro] screw with .260 [6.6mm] holes; **-or-** hex-head or pan head [M5 Euro] screw with .203 [5.2mm] holes.

**Wood Applications:** 1/4" lag or sheet metal screw **-or-** #10 lag or sheet metal screw. Maximum screw head of .190 [4.8mm] high by .500 [12.7mm] diameter for clearance.

## Optional Accessory Platform Brackets

Brackets provide four bottom-mount and two side-mount options. For bottom-mount, one bracket attaches to the slide outer member and the cabinet base. The other bracket attaches to the slide inner member and the platform or tray. For side-mount, the bracket attaches to the slide inner member.

See Figure 2 for examples of both mounting options. When the brackets are used either individually or in combination, they will accommodate all slide lengths. Each kit contains two brackets, four 1/4" hex-head screws, and four 1/4" hex nuts with lock washers. See separate Accessory Platform Bracket Kit data sheet for more information.

## Slide Ordering Instructions

### Locking Slide

The locking slide can be used on either the right hand side, left hand side, or both sides of the unit. After the length, specify "L" for left hand locking slide and "R" for right hand locking slide.

Complete your slide order for model 9308 or 9307 locking slide by specifying the following:

|                               |        |   |                |             |
|-------------------------------|--------|---|----------------|-------------|
| Total Required Slides         | 4 Each | C | 9308(07) -22-L | <b>-or-</b> |
| Slide Finish                  | 4 Each | C | 9308(07) -22-R |             |
| Locking Slide Model 9308 (07) |        |   |                |             |
| Slide Length                  |        |   |                |             |
| Locking Slide Hand            |        |   |                |             |

NOTE: For applications requiring a lock on both sides, order an equal amount of "L" and "R" hand slides.

### 9301 Non-Locking Companion Slide

Model 9301 is unhandred and can be used on either the left or right hand side of the unit. For each locking slide ordered, order 1 companion slide.

Complete your slide order for model 9301 companion slide by specifying the following:

|                            |        |   |      |     |
|----------------------------|--------|---|------|-----|
| Total Required Slides      | 4 Each | C | 9301 | -22 |
| Slide Finish               |        |   |      |     |
| Companion Slide Model 9301 |        |   |      |     |
| Slide Length               |        |   |      |     |

See 9301 data sheet for additional information.

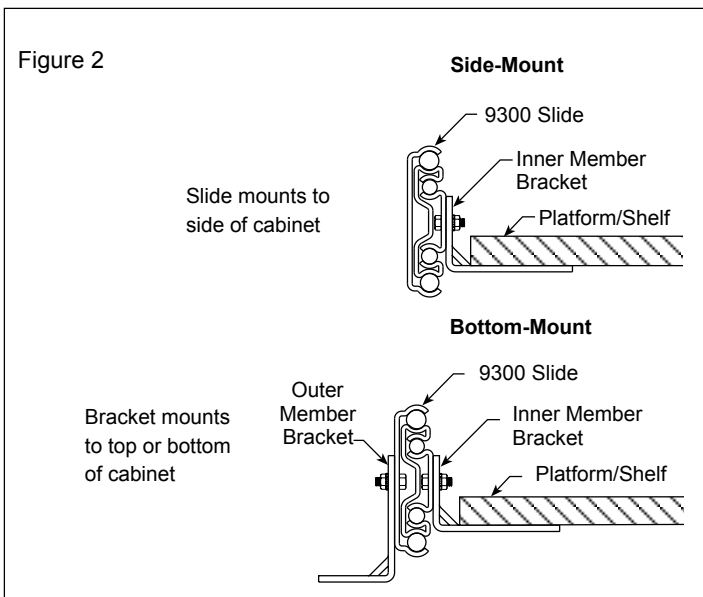
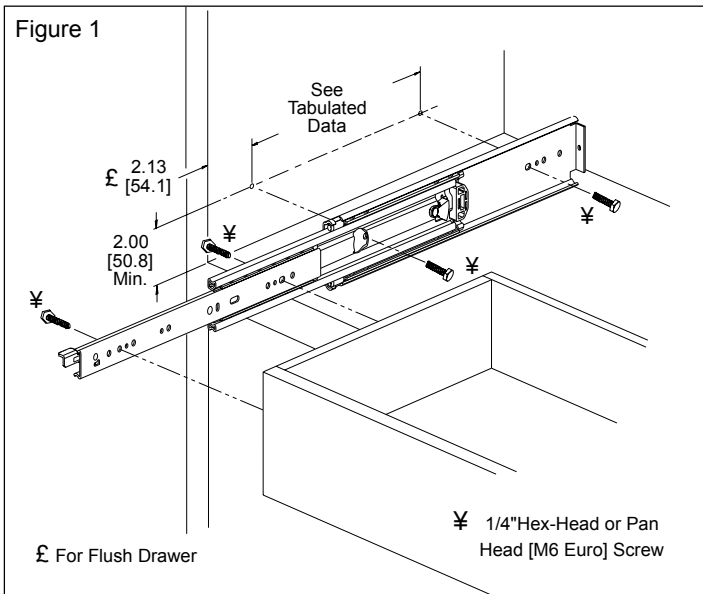

## Packaging

**Bulk Pack:** Slides only. Left and right hand slides packaged in separate boxes.

|                           |                |
|---------------------------|----------------|
| Slide Lengths: 12" to 22" | 8 each per box |
| 24" to 32"                | 4 each per box |

## Specifications

Slide members: Cold rolled steel  
 Ball retainers: Polymer  
 Ball bearings: Carburized steel

**Note:** Specifications, materials, prices, terms, and delivery are subject to change without notice.

# Accuride

ACCURIDE INTERNATIONAL INC.

12311 Shoemaker Avenue  
 Santa Fe Springs, CA 90670

TEL (562) 903-0200

FAX (562) 903-0208

www.accuride.com

Manufacturing, Engineering, and Sales  
 United States • Germany • Japan • Mexico • United Kingdom