



DECS-200N Negative Forcing Digital Excitation Control System

The DECS-200N is a very compact Negative Forcing Digital Excitation Control System. This compact design accommodates 63 Vdc and 125 Vdc applications up to 20 Adc continuously. The on-board six-thyristor controlled rectifier bridge offers the highest system performance possible, making the DECS-200N ideal for providing exceptional system response, which makes it suitable for applications requiring power system stabilizers.

FEATURES

- Multiple microprocessor-based design
- True RMS sensing, single or three phase
- $\pm 0.25\%$ Voltage Regulation Accuracy
- 63 Vdc and 125 Vdc output capability up to 20 Adc continuous
- Built-in 6 SCR power bridge
- Negative field forcing
- Highly compact design
- High initial response
- Soft start buildup
- Var and Power Factor operating modes with Autotracking
- Autotracking between operating modes and between dual DECS-200Ns
- On and off-line Overexcitation Limiter
- Customizable Underexcitation Limiter
- Stator Current Limiting
- Underfrequency compensation or V/Hz Ratio Limiter
- Field flashing control provisions
- Paralleling provisions
- Generator Protection
- Exciter Diode Monitoring (EDM)
- Oscillography and Sequence of Events Recording
- Voltage Matching
- 5 Programmable output contacts
- Modbus™ protocol via RS-485 communications

WINDOWS® SOFTWARE

Interface software for setting and communicating with DECS-200N
Request DECS-200N-CD

ADDITIONAL INFORMATION

INSTRUCTION MANUAL

Request Publication 9388800990

**DESCRIPTION and
SPECIFICATIONS**
Pages 2 through 5

**FEATURES and
FUNCTIONS**
Pages 6 and 7

**INTERCONNECT
DIAGRAM**
Page 8

**FRONT, SIDE VIEWS
and DIMENSIONS**
Pages 9 through 11

ORDERING
Page 12

DESCRIPTION

The DECS-200N is a multi-microprocessor based Negative Forcing Digital Excitation Control System designed into one complete compact package. This space-saving design consists of all the functionality needed to control, limit and protect a generator from operating outside the machine's capability. This is accomplished by the DECS-200N's impressive control algorithm coupled with a versatile 20A dc 6 SCR power bridge. The input of the power bridge can be fed by a 50 to 500 Hz, single or three phase voltage source, depending on the desired excitation levels it is intended to support.

The DECS-200N also incorporates four control modes of operation: Automatic Voltage Regulation (AVR), Field Current Regulation (FCR, Manual), Volt Amp Reactive (Var)

and Power Factor (PF) control. In addition to these control modes, the DECS-200N provides the ability for all non-active control modes to follow the set point of the active mode, permitting bumpless transfer between any other modes. For applications requiring redundancy, the DECS-200N can communicate unit-to-unit, allowing the backup DECS-200N to automatically follow the active unit's set point in the event it is necessary to switch to the backup DECS-200N. Communications with a PC is possible via a front panel RS-232 port for local programming and metering. Provisions for remote control are also available using contact inputs and the RS-485 port via Modbus protocol. The DECS-200N offers all of the features, functionality, flexibility, and programmability for use in new installations and in retrofit applications.

APPLICATION

The DECS-200N is a highly responsive negative forcing excitation control system used to control the output voltage, vars, or power factor of a synchronous generator by automatically adjusting the amount of dc excitation being applied to the generator's exciter field. Due to its negative forcing capabilities, the DECS-200N is ideal for virtually any size system that demands exceptional system response and/or requires Power System Stabilizers.

SPECIFICATIONS

INPUTS

Control Power

The DECS-200N incorporates redundant control power inputs. Both AC and DC voltage can be used to ensure source reliability.

DC Input

Nominal voltage: 24/48 Vdc (style LX) or 125 Vdc (style CX)
 Voltage range: 18 to 60 Vdc (style LX) or 90 to 150 Vdc (style CX)
 Burden: 30 W maximum

AC Input

Isolation transformer for ac input is required when dual control power sources (both AC and DC) are used.

Nominal voltage: 24 Vac (style LX) or 120 Vac (style CX)
 Voltage range: 20 to 40 Vac (style LX) or 82 to 132 Vac (style CX)
 Frequency: 50/60 Hz
 Burden: 40 VA maximum

AC Operating Power

Configuration: 1 phase or 3 phase
 Voltage range: 80 to 277 Vac
 Frequency range: 50 to 160 Hz (style X1), 161 to 420 Hz (style X2), or 421 to 500 Hz (style X3)

To achieve the desired forcing levels of the bridge output for the intended application, the appropriate operating power input voltage level must be applied. The table below lists the required nominal operating power voltage and configuration required to obtain 63 Vdc or 125 Vdc continuous field power. Refer to Exciter Diode Monitor (EDM) on page 4 if applied to brushless generators.

Parameter	For 63 Vdc Continuous Applications		For 125 Vdc Continuous Applications	
	1 Phase	3 Phase	1 Phase	3 Phase
Input Power Configuration	1 Phase	3 Phase	1 Phase	3 Phase
Nominal Input Voltage	208 Vac	120 Vac		240 Vac
Minimum Residual Voltage for Buildup	24 Vac	12 Vac	Not Recommended	24 Vac
Operating Power Input Burden at 20 A dc Excitation Output	4,160 Vac	3,400 VA		6,800 VA

SPECIFICATIONS, continued

Generator and Bus Voltage Sensing

- Single-phase or three-phase line voltage, four ranges:
- 100V/50Hz nominal (85 to 127V), 120V/60Hz nominal (94 to 153V)
 - 200V/50Hz nominal (170 to 254V), 240V/60Hz nominal (187 to 305V)
 - 400V/50Hz nominal (340 to 508V), 480V/60Hz nominal (374 to 600V)
 - 500V/50Hz nominal (425 to 625V), 600V/60Hz nominal (510 to 660V)

Generator Current Sensing

- Two ac current sensing ranges and two channel (phase) inputs:
- For metering and control: 1A and 5A.
 - For cross current compensation: 1A and 5A.

Sensing Burden

Voltage: Less than 1VA per phase. Current: Less than 1VA.
 Parallel Compensation: Less than 1VA.

Contact Switching Inputs

- 11 contact switching inputs are supplied with 24Vdc to accommodate dry contacts. Contacts are as follows:
- Start
 - Stop
 - Unit/Parallel Operation
 - AVR Mode
 - FCR Mode
 - Secondary DECS Enabled (optional)
 - Var/PF Enable
 - Pre-position
 - Raise Switch
 - Lower Switch
 - Alarm Reset

Remote Set Point Control (Accessory Input)

Two separate analog inputs for remote set point control. Typically used to accept a signal from a Basler Electric Power System Stabilizer (PSS-100). Select one from the configuration menu.

- ±10Vdc
- 4 to 20 milliamperes

OUTPUTS

Field Output

The table below lists the fields output capabilities of the DECS-200N. In order to achieve the listed forcing capabilities, the proper nominal input voltage must be applied to the DECS-200N operating power terminals (in the appropriate configuration). The impedance of the operating power source may affect the levels of the positive and negative forcing voltage. The forcing values listed assume a source impedance of 10%.

Parameter	For 63 Vdc Continuous Applications		For 125 Vdc Continuous Applications	
	1 Phase	3 Phase	1 Phase	3 Phase
Input Power Configuration	1 Phase	3 Phase	1 Phase	3 Phase
Nominal Input Voltage	208 Vac	120 Vac		240 Vac
Full-Load Continuous Excitation	63 Vdc	63 Vdc		125 Vdc
Max. Positive Forcing Voltage	130 Vdc	120 Vdc	Not Recommended	240 Vdc
Max. Negative Forcing Voltage	-105 Vdc	-100 Vdc		-200 Vdc
Max. Continuous Current	20 Adc	20 Adc		20 Adc
Maximum Forcing Current	40 Adc	40 Adc		40 Adc
Minimum Field Resistance	3.15 Ohms	3.15 Ohms		6.25 Ohms

Contact Output Ratings

Make and Break (Resistive)	Carry (Resistive)
24 Vdc @ 7.0A 48 Vdc @ 0.7A 125 Vdc @ 0.2A	24/48/125 Vdc @ 7.0A
120/240 Vac @ 7.0 A	120/240 Vac @ 7.0A

COMMUNICATION

There are three communication ports, two RS-232 and one RS-485:

- COM0: RS-232, 9 pin, sub-D connector located on front panel and used to communicate with local computers. 19200 baud, 8N1 full duplex, ASCII commands.
- COM1: RS-232, 9 pin, sub-D connector located on right side panel and used to connect primary and backup DECS-200 units. Port is only used to autotracking with backup DECS-200N.
- COM2: RS-485, located on left side panel and used to communicate with local or remote computers or other devices. 1200 to 19200 baud, 8N1 half duplex, Modbus protocol.

SPECIFICATIONS, continued

REGULATION ACCURACY

AVR Mode: Voltage regulation equals $\pm 0.25\%$ over the load range at rated power factor and constant generator frequency. Steady state stability equals $\pm 0.1\%$ at a constant load and generator frequency.

Temperature drift equals $\pm 0.5\%$ for 0 to 50°C temperature change. Underfrequency (volts/hertz) characteristic slope from 0 to 3.0 P.U. is adjustable in 0.1 P.U. increments.

FCR Mode: Field current regulation equals $\pm 1.0\%$ of the nominal value for 10% of the bridge input voltage change or 20% of the field resistance change.

var Mode: $\pm 2.0\%$ of the nominal VA rating at the rated frequency.

PF Mode: ± 0.02 PF in the set point PF for the real power between 10 and 100% at the rated frequency. (e.g. -set point PF = 0.80, PF regulation is from 0.78 to 0.82 PF.)

Internal autotracking (optional): $\pm 0.5\%$ of the nominal field voltage change when transferring.

PARALLEL COMPENSATION: Can use either reactive droop or reactive differential (cross-current) compensation. Adjustable from 0 to 30% of the rated generator voltage droop with optional 1 ampere or less or 5 amperes or less input. Line drop compensation uses this same parameter; however, it is adjustable from -30% to 0.

FIELD OVERVOLTAGE PROTECTION: Adjustable in increments of 1.0 Vdc from 1.0 to 325 Vdc rated output voltage with 0.2 to 30 second inverse time delay settable in increments of 0.1 second.

FIELD OVERCURRENT PROTECTION: Adjustable in increments of 0.1 Adc steps of rated field current from 0 to 22 Adc excitation current setting with an inverse time delay (ANSI C50.13).

EXCITER DIODE MONITOR (EDM): The DECS-200N's EDM can detect open and shorted diodes on brushless generators. To do this, the DECS-200N requires the user to input the number of generator poles and the number of exciter poles. The open and shorted diodes ripple threshold is adjustable from 0 to 100% of field current. The open diode protection time delay is adjustable from 10 to 60 seconds, and the shorted diode protection time delay is adjustable from 5 to 30 seconds.

For proper detection of an open diode on a brushless exciter, the following criteria must be met:

- The ratio between the number of generator poles and the exciter number of poles should be between 1.5 and 10.
(Pole Ratio = Number of Exciter Poles/Number of Generator Poles)
- Three phase operating power is required when input voltage is supplied from the generator output (shunt powered).

GENERATOR UNDERVOLTAGE PROTECTION: Adjustable in increments of 1 Vac from 0 to 30 kV sensing voltage setting with a 0.5 to 60 second time delay (ANSI C50.13) settable in increments of 0.1 sec.

GENERATOR OVERVOLTAGE PROTECTION: Adjustable in increments of 1 Vac from 0 to 30 kV sensing voltage with a 0.1 to 60 second time delay (ANSI C50.13) settable in increments of 0.1 second.

GENERATOR LOSS OF FIELD PROTECTION: Adjustable in increments of 1 kVar from 0 to 3,000 Mvar, with a 0.1 to 9.9 second delay settable in increments of 0.1 second.

LOSS OF SENSING: The loss of sensing setting for both balanced and unbalanced generator voltage is adjustable from 0 to 100% of nominal generator voltage. The protection delay is adjustable from 0 to 30 seconds in 0.1 increments.

SOFT START: Functional in AVR and FCR with an adjustable rate of 1 to 7200 seconds in one second increments.

SUMMING POINT and TAKEOVER TYPE

OVEREXCITATION LIMITING: Limiter response time is less than three cycles.

SUMMING POINT TYPE:

- On-Line **High Current Level:** (instantaneous) set point adjustable from 0 to 40.0 Adc in 0.1 Adc increments. Limiting occurs for a time period ranging from 0 to 10 sec., settable in 1 sec. increments.
- Medium Current Level:** set point adjustable from 0 to 30 Adc in 0.1 Adc increments. Limiting occurs for a time period ranging from 0 to 120 seconds, settable in 1 sec. increments.
- Low Current Level:** set point adjustable from 0 to 20 Adc in 0.1 Adc increments. Limiting occurs indefinitely.

SPECIFICATIONS, continued

Off-Line **High Current Level:** (instantaneous) set point adjustable from 0 to 40Adc in 0.1Adc increments. Limiting occurs for a time period ranging from 0 to 10 seconds, settable in 1 second increments.
Low Current Level: set point adjustable from 0 to 20Adc in 0.1Adc increments. Limiting occurs indefinitely.

TAKEOVER TYPE OEL: The Takeover OEL uses an I²t characteristic.

On-Line **High Level:** High Current Level (instantaneous) set point is adjustable from 0 to 40.0Adc in 0.1 Adc increments.
Low Level: Low Current set point is adjustable from 0 to 20.0Adc in 0.1Adc increments. Limiting occurs indefinitely.

Time Dial - This setting determines the inverse time curve selected.

Off-Line **High Level** - High current level (instantaneous) set point is adjustable from 0 to 40.0Adc in 0.1Adc increments.

Low Level - Low current set point is adjustable from 0 to 20.0Adc in 0.1Adc increments. Limiting occurs indefinitely.

Time Dial - This setting determines the inverse time curve selected.

UNDEREXCITATION LIMITING Adjustments based on generator ratings.

STATOR CURRENT LIMITING

High Level - High current level set point adjustable from 0 to 60,000Aac in 0.1Aac increments. Limiting occurs for a time period ranging from 0 to 60 seconds, settable in 0.1 sec. increments.

Low Level - Low current level set point adjustable from 0 to 60,000Aac in 0.1Aac increments. Limiting occurs indefinitely.

SEQUENCE OF EVENT RECORDING (SER) 127 event reports stored in volatile memory (retrievable via BESTCOMS). SER triggered by: Input/Output status changes, system operating status changes, and alarm annunciations.

OSCILLOGRAPHY Stores 8 records. Up to 6 variables can be logged in a record. Sampling rate: 600 data points per log, pre-trigger adjustable from 0 to 599 data points, 4ms to 10sec intervals between data points (2.4sec to 6000sec. total log duration)

MANUAL EXCITATION CONTROL Regulates field current from 0 to 20.0A in increments of 0.1Adc.

VOLTAGE MATCHING Matches utility bus RMS voltage with generator output RMS voltage within $\pm 0.15\%$ of the generator voltage. Bus sensing is single phase L-L voltage monitoring magnitude.

REAL TIME CLOCK Time displayed in either 12 hour or 24 hour format and can be selected to allow for daylight savings timer. The date is selectable for two formats: d-m-y or m/d/y. Requires control power to operate. If power is lost, the clock will need to be reset.

HIGH POT. IEEE 421.3

ENVIRONMENTAL

Humidity IEC 68-1, IEC 68-2-28

Operating temperature: -40°C to +60°C (-40°F to +140°F)

Style X3 only: 0°C to +60°C (0°F to +140°F) for high frequency version

Storage temperature: -40°C to +85°C (-40°F to +185°F)

Salt Fog Per MIL-STD-810E, Method 509.3 (100 hrs. of salt fog, 100 hours of drying time)

Shock 15 Gs in each of three mutually perpendicular planes

Vibration 5-26Hz: 1.2Gs; 27-52Hz: 0.914mm (.036 inch) double amplitude; 53-500Hz: 5.0Gs

Size 8.96" (228mm) wide x 7.94" (202mm) deep x 14.03" (356mm) high

Weight 14 lbs. (6.35kg)

AGENCY cURus recognition per UL Standard 508, File E97035 and CSA Standard C22.2 No. 14.
 GOST-R certified per the relevant standards of Gosstandart of Russia.
 Republic of Belarus Certificate of Conformity: Byelorussian certified.

FEATURES/FUNCTIONS

Voltage Regulation

The DECS-200N regulates the generator RMS voltage to within 0.25% from no-load to full-load. It does this by utilizing digital signal processing and precise regulation algorithms developed by Basler Electric, utilizing the experience gained in many years of manufacturing tens of thousands of digital voltage regulators.

Stability

The DECS-200N utilizes proportional (P), integral (I) and derivative (D) stability control. DECS-200N has 20 preprogrammed stability (PID) settings for exciter field applications. This means that a standard stability setting is already available for most applications/machines. The DECS-200N has a stability range that allows for customizing the stability settings to fine tune the stability to provide optimum customized generator transient performance. Setup software contains PID selection program to assist in determining the correct PID settings. The DECS-200N provides for customizing the stability and transient performance of the Min/Max Excitation Limiter and var/PF controllers by providing additional stability adjustments.

Underfrequency Limiter or V/Hz Ratio Limiter

DECS-200N is selectable for either Underfrequency Limiter or a V/Hz Ratio Limiter function. The underfrequency limiter slope can be tuned to have 0 to 3 times p.u. Volts/Hz, in 0.1Hz increments, and the corner frequency roll-off point can be set across a range of 45 to 65Hz, in 0.1Hz increments. This adjustability allows the DECS-200N to precisely match the operating characteristics of the prime mover and the loads being applied to the generator. The Volts/Hz Ratio Limiter clamps the regulation set point to prevent operation above a V/Hz level that is prescribed by the slope of the DECS-200N. This feature is also useful for other potentially damaging system conditions such as a change in system voltage and reduced frequency situations that exceed the V/Hz ratio.

Soft Start Voltage Buildup

Generator voltage overshoot can be harmful to the generator's insulation system if not controlled. DECS-200N has a soft start feature with a user-adjustable setting to govern the rate at which the generator voltage is allowed to build up. This reduces the amount of generator voltage overshoot from nominal operating voltage during start-up of the generator system.

Paralleling Compensation

DECS-200N has provisions to parallel two or more generators using reactive droop or reactive differential compensation with the addition of an external current transformer with secondary currents of 1 or 5Aac. The current input is rated at less than 1VA. This low burden means that existing metering CTs can be used and dedicated CTs are not required.

Set Point Control

DECS-200N has means for external set point adjustment of the controlling mode of operation. This eliminates the need for additional equipment like motor operated potentiometers for remote control or multiple point control for the excitation system. The operating mode's set point may be directly controlled by raise/lower contact inputs, auxiliary inputs of 4-20mA or ± 10 Vdc. The auxiliary input adjusts the operating mode across its predetermined adjustment range. The auxiliary input can be

provided from other controlling devices such as a power system stabilizer. These devices modify the operation of the DECS-200N to meet specific operating characteristics and requirements for the machine under DECS-200N control. Two more methods of set point control may be achieved via the RS-232 communication port by using the Windows® based PC software or by the RS-485 port using Modbus™ protocol. Regardless of which method of set point is used (contact inputs, auxiliary input or communications with a PC or PLC), traverse rates of all modes of operation are independently adjustable. This means an operator can customize the rate of adjustment and "feel" to meet his/her needs.

Pre-position Inputs

DECS-200N provides the added flexibility of allowing a predetermined operating point for each mode of operation. With a contact input to the DECS-200N, the operating mode is driven to an operating or regulation level assigned to that operation mode by the operator or user. The pre-position inputs operate in one of two modes, Maintain or Release. The Maintain mode prevents adjustment of the setpoint as long as the pre-position contact is closed. The release mode allows adjustment of the setpoint even though the pre-position is closed. This feature allows the DECS-200N to be configured for specific system and application needs.

Field Current Regulation Operating Mode

DECS-200N provides a manual channel of operation called Field Current Regulation, or FCR, Mode. In this mode, DECS-200N regulates the field current generated by the internal power stage. It does not rely on the sensing input to DECS-200N and is, therefore, a good source of backup excitation control when loss of sensing is detected. In this mode, control of the generator is totally dependent upon the operator to maintain nominal generator voltage as the load varies on the generator.

Var/Power Factor Controller Operating Mode

DECS-200N has, as another standard feature, two modes of operation when the generator is in parallel with the utility power grid. The DECS-200N has both var and PF modes of operation. When the generator is in parallel with the utility grid, the DECS-200N can regulate the var output of the generator to a specific var level magnitude or it can vary the var output of the generator to maintain a specific power factor as the kW load varies on the generator.

Maximum Excitation Limiters

Overexcitation limiting (OEL) operates in all modes except FCR mode. OEL senses the field current output of the voltage regulator and limits the field current to prevent field overheating. In FCR mode, the DECS-200N only announces that all conditions for OEL are fulfilled and does not provide limiting. The DECS-200N provides two types of overexcitation: Summing Point and Takeover.

Summing Point Type OEL

Three OEL current levels are defined for on-line operation. They are high, medium, and low. Two OEL current levels are defined for off-line (main breaker open) operation. They are high and low.

FEATURES/FUNCTIONS, continued

Takeover Type OEL

The field current level at which limiting occurs is determined by an inverse time characteristic. Two current levels and a time dial setting are defined for the takeover-style OEL limiter. Separate curves may be selected for on-line and off-line operation. If the system enters an overexcitation condition, the field current is limited and made to follow the selected curve. The selection of on-line or off-line OEL levels/curves is determined by an OEL option selection.

Minimum Excitation Limiter

The minimum excitation limiter limits the amount of excitation supplied to the field of the generator from dropping below unsafe operating levels. This prevents damage to the machine from possibly slipping poles. It limits the amount of vars being absorbed by the machine, based on user-definable settings. An internally generated Underexcitation Limiting (UEL) curve can be utilized based on a var level at 0kW, or a customizable 5 point UEL curve can be selected to match specific generator characteristics.

Stator Current Limiter

The stator current limiter (SCL) senses the level of stator current and limits it to prevent stator overheating. The SCL operates in all modes except FCR. In FCR mode, the DECS-200N only announces that a stator overcurrent condition exists; it does not provide current limiting. Two SCL current levels are provided: high and low.

Internal Autotracking Between DECS-200N Operating Modes

DECS-200N is an intelligent device that can provide autotracking (autofollowing) of the controlling mode by the non-controlling modes. This allows the operator to initiate a controlled, bumpless transfer of the DECS-200N operating modes, causing minimum amounts of line disturbance for the power system. This feature can be used in conjunction with a set of protective relays to initiate a transfer to a backup mode of operation, such as FCR mode, upon the detection of a system failure or fault, i.e., loss of sensing.

External Autotracking between Dual DECS-200N Units

A DECS-200N can also follow (autotrack) a second DECS-200N unit. The second DECS-200N is put into a specific operating mode and follows the excitation level of the first. In the unlikely event of a failure of the first DECS-200N, protective relays can initiate a transfer of control from the first to the second DECS-200N.

Protective Functions

There are several protection functions built into the DECS-200N unit. These functions may be used as backup to the primary protection relays and can be assigned programmable output contacts via the PC software. The protection features offer fully adjustable tripping levels and time delays. The protective features are:

- Generator Overvoltage
- Generator Undervoltage
- Field Overvoltage
- Field Overcurrent
- Crowbar fired
- Watchdog Timer
- Loss of Sensing
- Loss of field
- EDM Exciter Diode Monitor
- Failed to build up

Sequence of Events Recording (SER)

A sequence of event report (SER) is a very powerful tool when reconstructing the exact timing of an event or disturbance. The DECS-200N monitors its contact inputs and outputs for a change of state, system operation changes, and alarm conditions. If any of these events occurs, the DECS-200N will log that event with a date and time stamp. Date and time stamping of the event allows the user to recreate a chain of events in the sequence in which they occurred. The DECS-200N can store 127 events in volatile memory, and those events are retrievable using BESTCOMS.

Oscillography

The data recording feature can record up to eight (8) oscillographic records stored in volatile memory. The user can select up to six (6) variables to be monitored when triggered by the DECS-200N BESTCOMS, a Logic Trigger, or a Level Trigger. Variables that can be selected are: generator voltage, current (single phase), frequency, kW, Power Factor, exciter field voltage, and current.

The user can utilize the DECS-200N BESTCOMS to trigger and save a record of a voltage step response during commissioning. Once commissioned, a logic trigger or level trigger can be used to activate the data recorder to capture the occurrence for review at a later time. DECS-200N alarms can also be used to start the data recorder. When an alarm condition occurs, an oscillographic record can be stored. A level trigger will initiate a record to be saved when a variable exceeds a predetermined setting. An example of this is when the exciter field current exceeds a predetermined setting.

The oscillographic records are recorded in accordance with the IEEE Standard Common Format for Transient Data Exchange (COMTRADE). Basler Electric can provide BESTWAVE, a COMTRADE viewer, which is a program that will allow the user to view the oscillography records saved by the DECS-200N.

Communications

DECS-200N comes complete with Windows® based PC software. This software makes the programming and customizing the DECS-200N easy and fast. The software comes with a PID selection program that allows the user to select stability settings quickly and easily in a user-friendly format. The PC software has a special monitoring function that allows the user to view all settings, a metering screen for viewing all machine parameters, and a control screen for remote control of the excitation system.

The RS-485 port supports Modbus™ communications protocol. This is an open protocol with all registers and operating instructions available in the instruction manual, to make it simple for the user to develop custom communications software.

Password Protection

All DECS-200N parameters are viewable via the front panel LCD display, the PC software or via Modbus™ without the need of a password. If the user wishes to change a setting, the proper password must be entered to allow access to the parameter. Two levels of password protection exist, one for global access of all parameters and one for a limited amount of access to parameters normally associated with operator control.

CONNECTIONS

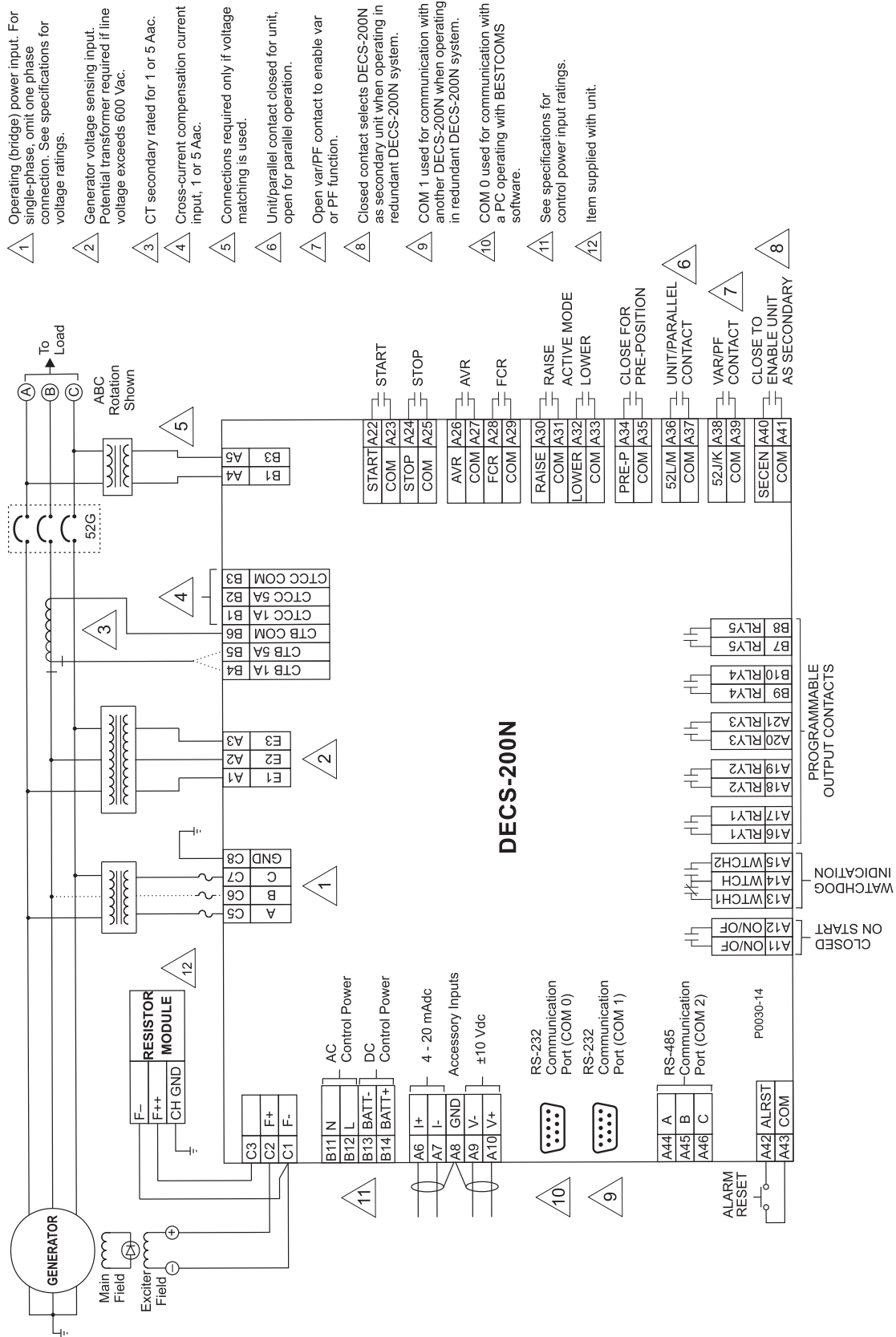

- 1 Operating (bridge) power input. For single-phase, omit one phase connection. See specifications for voltage ratings.
- 2 Generator voltage sensing input. Potential transformer required if line voltage exceeds 600 Vac.
- 3 CT secondary rated for 1 or 5 Aac.
- 4 Cross-current compensation current input, 1 or 5 Aac.
- 5 Connections required only if voltage matching is used.
- 6 Unit/parallel contact closed for unit, open for parallel operation.
- 7 Open var/PF contact to enable var or PF function.
- 8 Closed contact selects DECS-200N as secondary unit when operating in redundant DECS-200N system.
- 9 COM 1 used for communication with another DECS-200N when operating in redundant DECS-200N system.
- 10 COM 0 used for communication with a PC operating with BESTCOMS software.
- 11 See specifications for control power input ratings.
- 12 Item supplied with unit.

Figure 1 - Typical Connection Diagram

FRONT and SIDE PANEL VIEWS

The front panel HMI (Human Machine Interface) is composed of several elements, including a backlit LCD screen, six (6) pushbuttons and six (6) LEDs. The LCD is the primary interface because it conveys the majority of the information between the DECS-200N and the user/operator. Front panel pushbuttons allow the user to view menu screens and modify the various screen settings and operating conditions. The LEDs annunciate their respective states.

A) 64x128 pixel graphic LCD with backlighting. Primary source for receiving information from the DECS or when locally programming settings. Displays operations, set points, loop gains, metering, protection functions, system parameters and general settings.

B) Pre-Position LED – Turns ON at the predefined setting (within the limits of the set points) of the current mode.

C) Lower Limit LED – Turns ON at the minimum set point value of the current (active) mode.

D) Upper Limit LED – Turns ON at the maximum set point value of the current mode.

E) Scrolling Pushbuttons – Scrolls UP/DOWN/LEFT/RIGHT through the menu tree or when in the EDIT mode, the LEFT/RIGHT scrolling pushbuttons select the variable to change and the UP/DOWN scrolling pushbuttons change the variable.

F) Reset Pushbutton – Cancels editing sessions and can be used as a quick-access to the metering screen.

G) Serial Port COM0 – D-type 9 pin connector. This port is dedicated to RS-232 (ASCII commands) communication with a computer terminal or PC running a terminal emulation program such as BESTCOMS™.

H) Edit Pushbutton – Enables settings changes. When the EDIT pushbutton is first pushed, an LED on the pushbutton turns ON to indicate the edit mode is active. When changes are complete (using the scrolling pushbuttons) and the EDIT pushbutton is pushed again, the LED turns OFF, indicating the changes are saved. If changes are not completed and saved within five minutes, the edit mode is exited without saving changes.

I) Null Balance LED – Turns ON when the inactive modes (AVR, FCR, var, or PF) match the active mode.

J) Internal tracking LED – All inactive modes (AVR, FCR, var, or PF) track the active mode to accomplish the bumpless transfer when changing active modes.

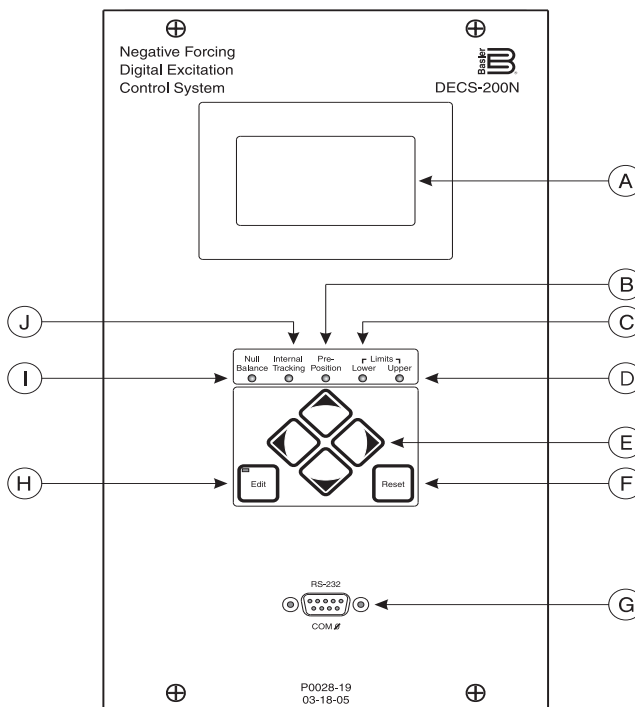

Figure 2a - Front Panel View

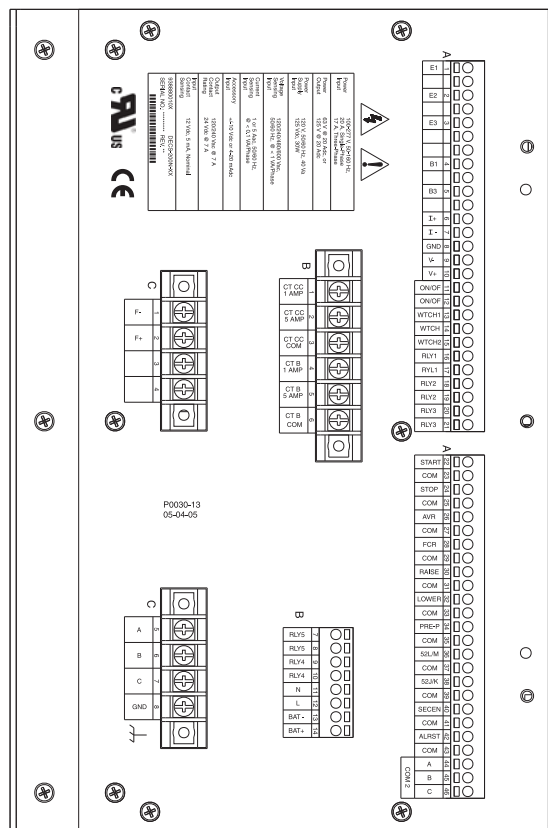

Figure 2b - Side Panel View

DIMENSIONS

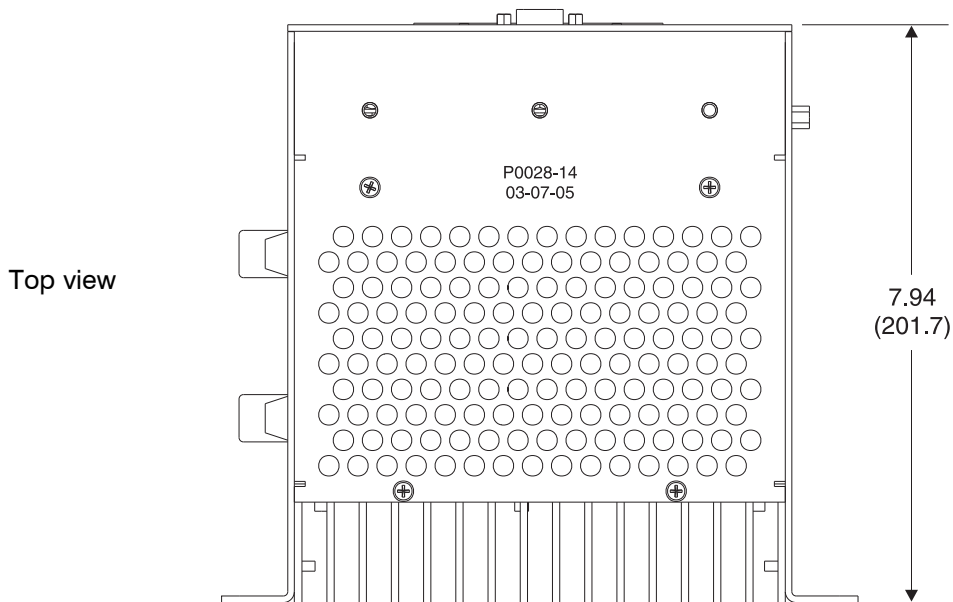
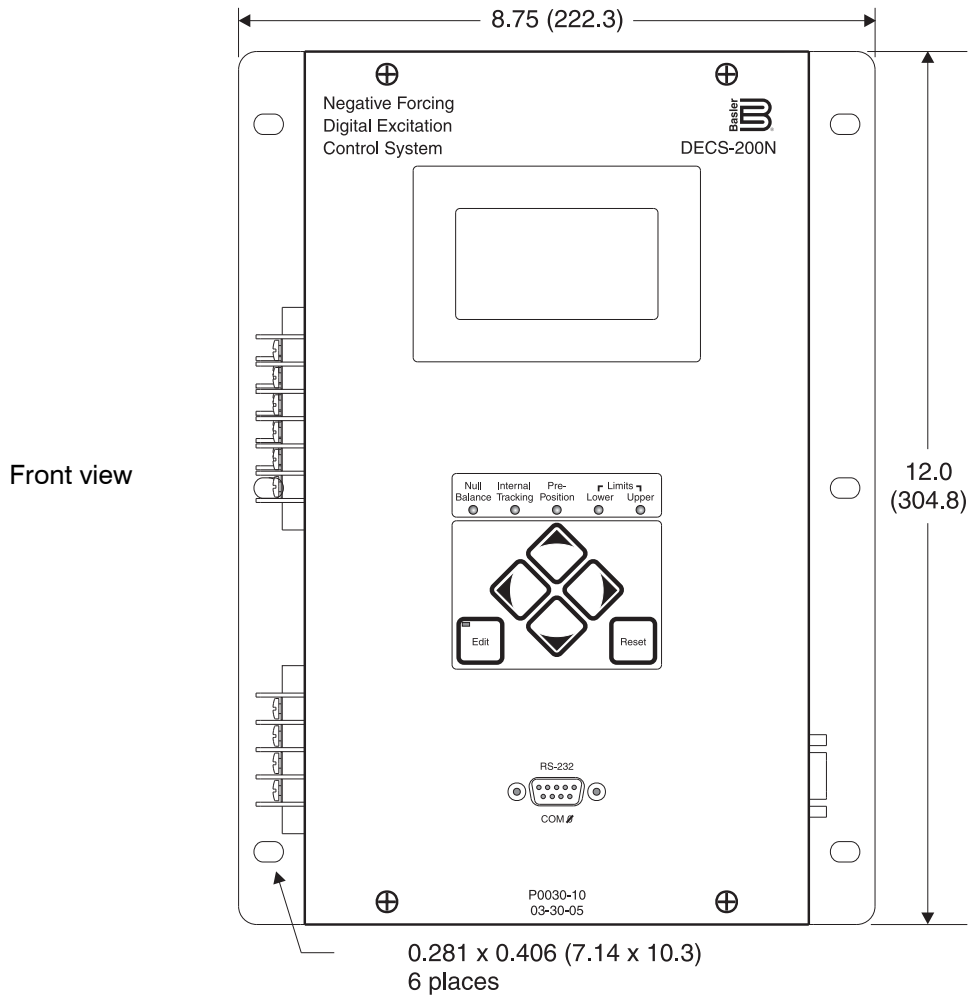
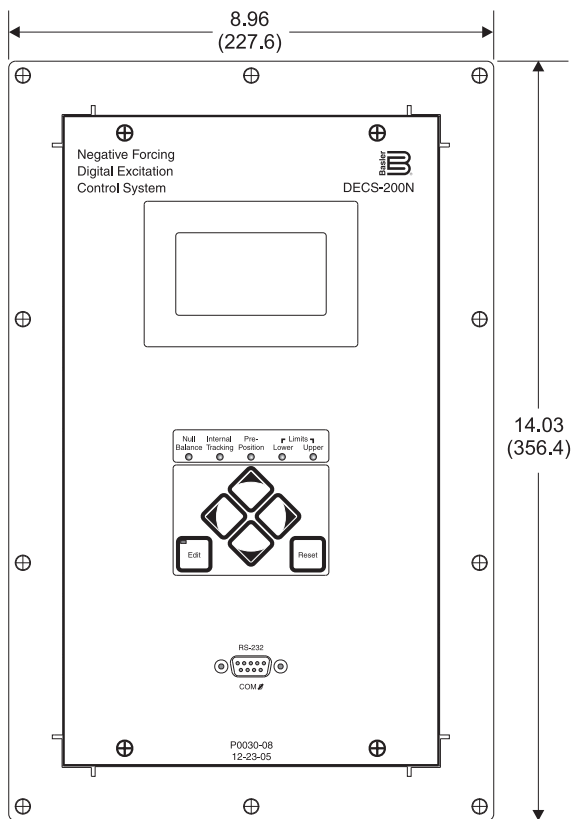

Figure 3 - Dimensions

ACCESSORIES

- Front panel mounting bracket, Basler P/N 9388807100. See Figure 4.
- Interconnection cable for dual DECS-200N applications, Basler P/N 9310300032.
- Field Flashing Chassis, Basler P/N 9399200100.
- Control Power Isolation Transformer, Basler P/N BE31449-001. (120Vac: 120Vac). Isolation required on AC control power input when dual control power sources are used.
- The IDP-800 Interactive Display Panel is a high-resolution, 7.5 inch (diagonal), color touch screen HMI that permits the operator to monitor the DECS-200N's excitation system status, perform control operations, and make routine adjustments to various set points. This next generation HMI can be placed locally on the exciter cabinets or remotely in a control room, via two-wire RS-485 (4,000 feet maximum distance from DECS). For more details, see Product Bulletin SZV.



NOTE: Use provided hardware when attaching escutcheon plate to DECS-200N.

Figure 4 - Front Panel Mounting Bracket, P/N 9388807100

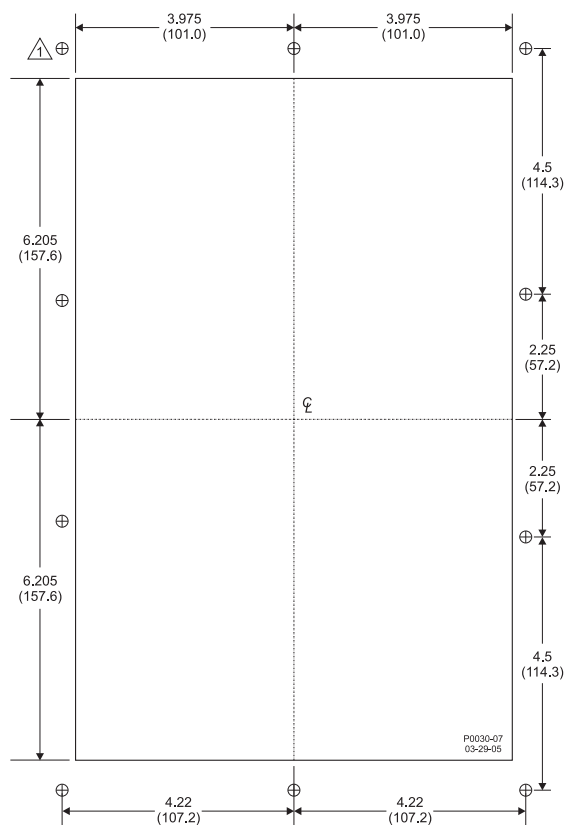

△ Mounting holes (10 places) are 0.218 (5.54) diameter.

Figure 5 - Front Panel Cutout Dimensions (Requires mounting bracket shown in Figure 4.)

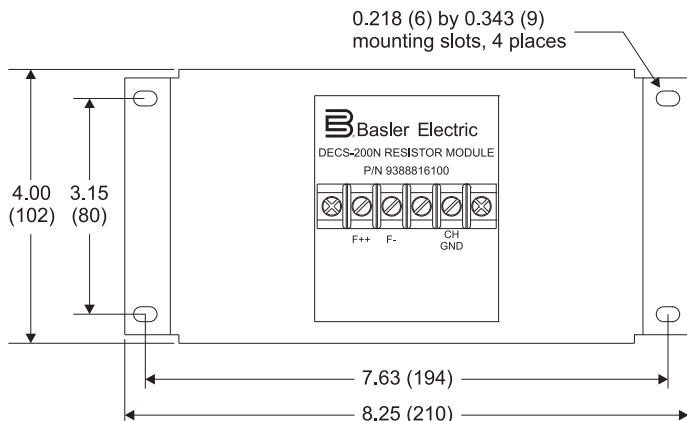
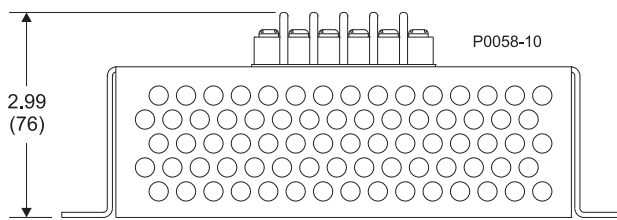
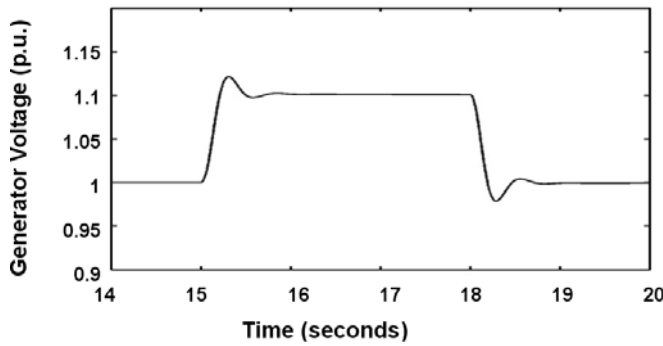

Figure 6 - Resistor Module, P/N 9388816100





(a) $K_G = 5$ with negative field forcing

Voltage regulators with Negative Forcing can improve the generator voltage response time during load transients. As an example, the diagram to the left represents a typical response characteristic for a voltage step change on a generator that utilizes a Negative Forcing Voltage Regulator for control. This should be compared to the lower left diagram with the same voltage step change; however, the generator is being controlled by a Non-Negative Forcing Voltage Regulator. The voltage overshoot can be minimized by lowering the gain to make the system less responsive, although this affects the overall system response by making it more sluggish, as seen below.

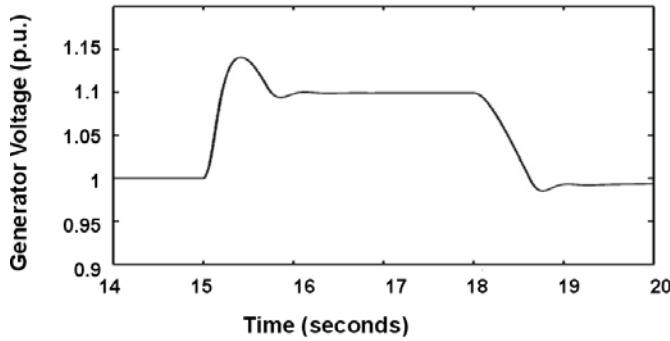

(b) $K_G = 5$ with no negative field forcing

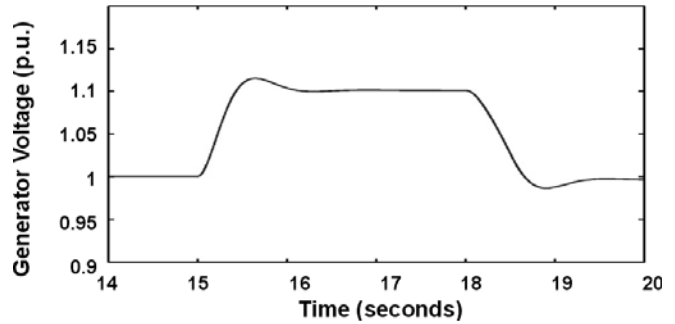

(c) $K_G = 1$ with no negative field forcing

HOW TO ORDER

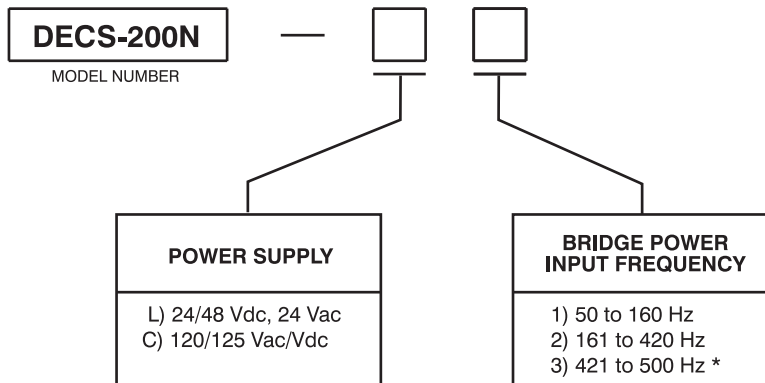

* See Operating Temperature Range, page 5.



ISO9001-2000
Highland, IL USA Taylor, TX USA
Wasselonne, France Suzhou, China



Route 143, Box 269, Highland, Illinois U.S.A. 62249
Tel +1 618.654.2341 Fax +1 618.654.2351
e-mail: info@basler.com

www.basler.com

P.A.E. Les Pins, 67319 Wasselonne Cedex FRANCE
Tel +33 3.88.87.1010 Fax +33 3.88.87.0808
e-mail: franceinfo@basler.com

No. 59 Heshun Road Loufeng District (N),
Suzhou Industrial Park, 215122, Suzhou, P.R.China
Tel +86(0)512 8227 2888 Fax +86(0)512 8227 2887
e-mail: chinainfo@basler.com

55 Ubi Avenue 1 #03-05 Singapore 408935
Tel +65 68.44.6445 Fax +65 65.68.44.8902
e-mail: singaporeinfo@basler.com