

NPort 6110 Modbus/TCP to Serial Communication Gateway

Easy-to-use Ethernet to RS-232/422/485 Modbus Gateway

Features

- Modbus serial and Ethernet device integration
- Supports Modbus/TCP Master device to Modbus/ASCII/RTU slave devices (up to 31)
- Supports Modbus/ASCII/RTU master device to Modbus/TCP slave devices (up to 4)
- Easy-to-use Windows utility for configuration over Ethernet
- 10/100M fast Ethernet with automatic IP setting (DHCP)
- One software selectable RS-232/422/485 interface
- High speed serial up to 230.4 Kbps



Seamless Integration of Ethernet and Serial Modbus Devices

Modbus is one of the most popular automation protocols in the world. Modbus protocol supports traditional RS-232/422/485 devices and newly developed Ethernet devices. Many industrial devices, such as PLCs, DCSS, HMIs, instruments, and meters, use Modbus as their communication standard. However, the Modbus protocol running over serial and Ethernet are so different that a communication gateway

is needed as a bridge for integration. NPort 6110 supports one Ethernet and one software selectable RS-232/422/485 port that can connect with all kinds of Modbus devices. By translating Modbus/TCP (Ethernet) and Modbus/ASCII/RTU (Serial) protocols, a PLC with Ethernet can use the RS-232/485 interface to seamlessly communicate with instruments.

Powerful Operation Modes for Versatile Modbus Applications

For Modbus protocol conversions, it is necessary to define a Master and Slave device, but unlike other Modbus Gateways, NPort 6110 allows users to configure Master/Slave for both the Ethernet and serial sides. Extra address mapping and exception parameters are supplied to ensure that most situations can be handled.

Windows Utility For Easy Setup and Traffic Monitoring

NPort 6110 is powerful yet very easy to use. An intuitive Windows utility automatically searches for all available NPort 6110 units on the LAN. Traffic Monitoring within the utility helps you troubleshoot any Modbus communication problem, such as connection status check, or address translation error check.



Typical Applications

Serial master device talks to serial slave devices over the Internet

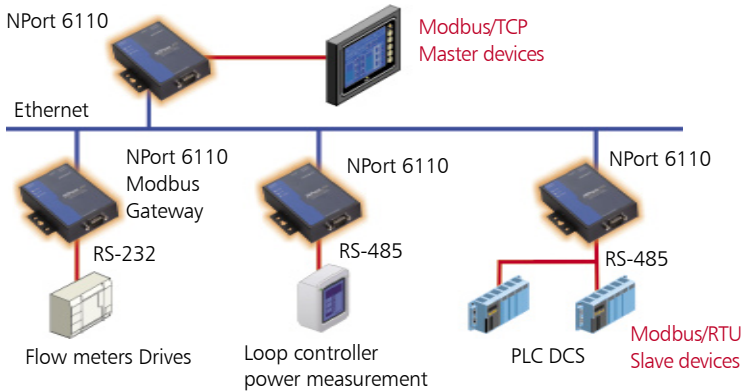

Let traditional Modbus serial devices talk over the Internet

Many traditional serial Modbus devices can talk over RS-485, but the RS-485 network limits the maximum number of Modbus devices to 32, within 1.2 km.

By using Modbus Gateway, you can link all Serial Modbus devices over an Ethernet network. Up to 8 Modbus Gateways can be installed in the same control network, extending the coverage of a single Modbus network as far as a TCP/IP network can reach.

Ethernet master devices talk to multiple serial slave devices

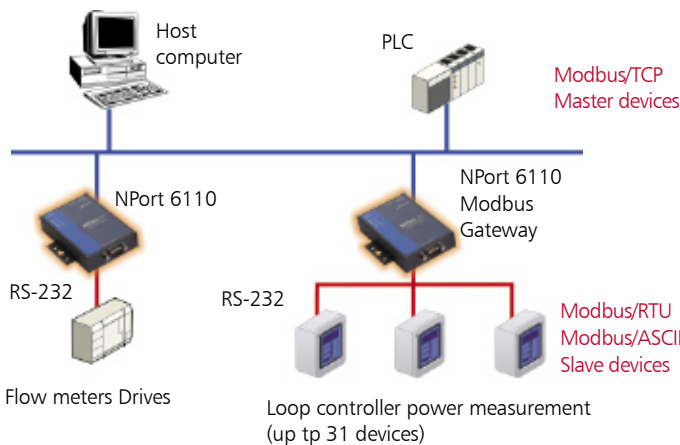

Connect all Modbus devices over the Ethernet network

Most host computers and newly developed PLCs support the Ethernet interface and run Modbus/TCP. NPort 6110 Modbus Gateway is needed to link discrete Serial Modbus Devices for data collection and control.

Each NPort 6110 supports Modbus/TCP over Ethernet, which allows up to 7 connections. The software configurable serial interface supports either RS-232 or RS-422/485. In RS-232/422 modes, NPort 6110 can connect to 1 serial device. One NPort 6110 supports up to 31 serial devices under RS-485 mode, which is the most popular application for the factory floor.

Serial master devices talk to multiple Ethernet slave devices

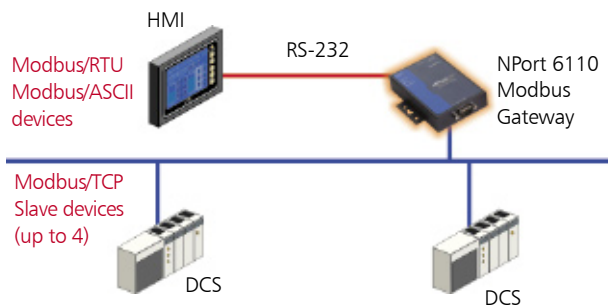

Link the serial master devices with Ethernet slave devices

Many HMI (Human Machine Interface) systems use a serial interface and are required to access a discrete DCS. These days, however, more and more DCSs support Ethernet and run under Modbus/TCP slave mode. In this case, NPort 6110 Modbus Gateway is the ideal solution to link the HMI to distributed DCSs over an Ethernet network. Up to 4 Modbus/TCP slave devices are supported for each NPort 6110.

Easy-to-use Windows Utility

Configure Modbus Gateway Anywhere on the LAN

Once NPort 6110 is connected to the Ethernet, any Windows host computer running Modbus Gateway Configurator can automatically search for all installed Modbus Gateways, and then proceed with configuration. DHCP (Automatic IP settings) and Manual IP settings are both supported. Such user-friendly features make NPort 6110 one of the most easy-to-use Modbus Gateways in the world.

Online Traffic Monitoring and Error Log Display

Modbus communication troubleshooting is both fast and easy. NPort 6110's utility lets you monitor the online configuration and connection status from anywhere on the network without interfering with operation. Meanwhile, the system log can be stored as an installation or service record.

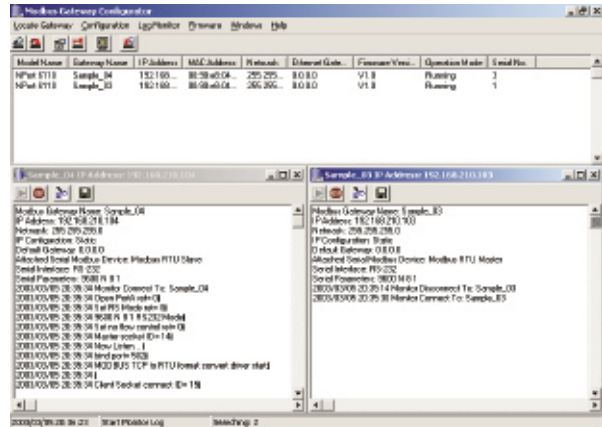

Comprehensive and Powerful Modbus Parameter Settings

In addition to working with most Modbus devices, NPort 6110 provides both basic and advanced communication parameters. For example, in addition to general configurations, Remote Modbus/TCP device ID, Initial Delay Time Adjustment, and Character/Message Timeouts are adjustable right in the Windows utility. Unlike text-based configuration from other vendors, NPort 6110's comprehensive utility eases installation and saves training cost for engineers.

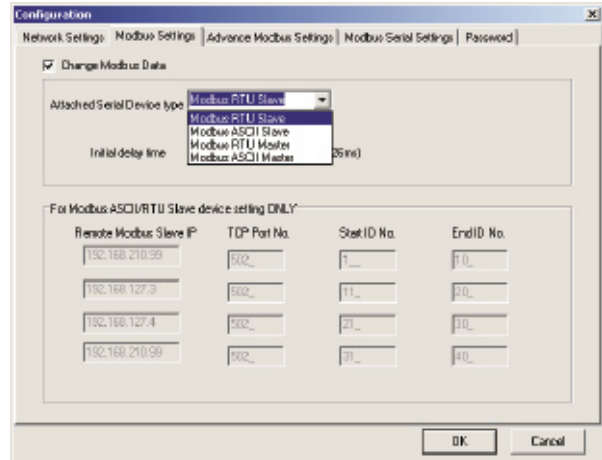
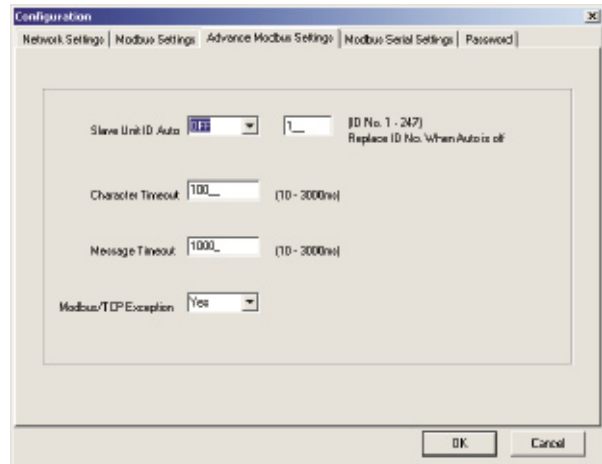

Monitor and Log display

Specifications

LAN

Ethernet: 10/100 Mbps, RJ45

Protection: Built-in 1.5 KV magnetic isolation

Serial

Interface: RS-232/422/485 x 1, DB9 (M), software selectable

RS-232 Signals: TxD, RxD, RTS, CTS, DTR, DSR, DCD, GND

RS-422 Signals: Tx+, Tx-, Rx+, Rx-, RTS+, RTS-, CTS+, CTS-, GND

RS-485 (2-wire) Signals: Data+, Data-, GND

Serial Line Protection: 15 KV ESD for all signals

RS-485 Data Direction: Patented Automatic Data Direction Control (ADDC™)

Serial Communication Parameters

Parity: None, Even, Odd, Space, Mark

Data Bits: 7, 8

Stop Bit: 1, 2

Flow Control: RTS/CTS, XON/XOFF

Speed: 1200 bps to 230.4 Kbps

Software Features

Internet Protocols: DHCP, BootP, TCP, UDP, IP, ICMP, ARP

Modbus Protocols:

Modbus/TCP, Modbus/ASCII, Modbus/RTU, Master/Slave modes supported

Utilities: Modbus Gateway Configurator for Windows 95/98/ME/NT/2000/XP/2003

Configuration: Windows utility via Ethernet

Power Requirements

Power Input: 9 to 30 VDC

Power Consumption: 300 mA at 12V (max.)

Mechanical Specifications

Material: Aluminum sheet metal (1mm)

Gross Weight: 0.5 kg (1.1 lb)

Environmental

Operating Temperature: 0 to 55°C (32 to 131°F),

5 to 95% RH

Storage Temperature: -20 to 85°C (-4 to 185°F), 95% RH

Regulatory Approvals

EMC: FCC Class B, CE Class B

Safety: CUL, TÜV

Pin Assignment

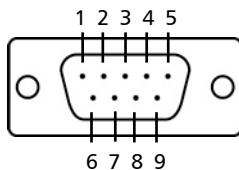

Pin	RS-232	RS-422	RS-485(2W)
1	DCD	TxD-(A)	Data-(A)
2	Rx	TxD+(B)	Data+(B)
3	Tx	RxD+(B)	-
4	DTR	RxD-(A)	-
5	GND	GND	GND
6	DSR	RTS-(A)	-
7	RTS	RTS+(B)	-
8	CTS	CTS+(B)	-
9	-	CTS-(A)	-

Dimensions

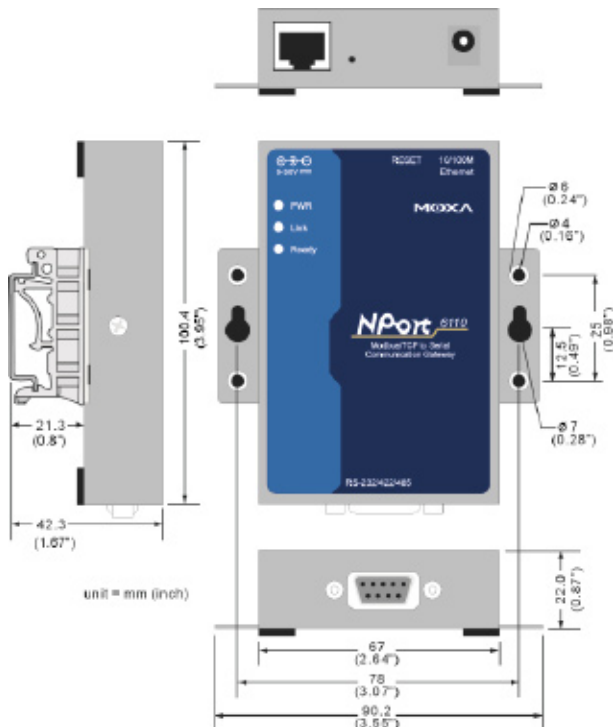

Ordering Information

NPort 6110: Modbus/TCP to Serial Gateway with 100-240 VAC power adaptor (US, Euro plugs included, 12 V, 400 mA)

Optional Accessories

DK-35A: DIN-Rail Mounting Kit (35 mm)