

No. HVR250

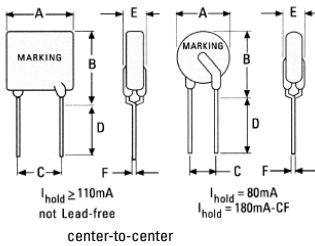

Devices are not intended for continuous use at 250 V!

Dimensions (mm)



High Voltage PTC Device, 60 V / 250 V

Standard
UL 1434 1st Edition
CSA C22.2 No. 0 CSA TIL No. CA-3A

Approvals
cULus Recognition
TÜV

Features

This product line is designed to provide protection against induced AC power current, direct power contact and the natural lightning strike. The HVR250 product line is widely used in the field of telecommunications and networking, ISDN and XSDN equipment. It also helps equipment manufacturers pass ITU K20, K21 and telcordia requirements.

WebLinks

Further info see:
www.wickmanngroup.com

Further application info see fuseology:
www.wickmanngroup.com/download/fuseology.pdf



Specifications

Packaging

A: bulk
F: tape and ammo

Materials

Insulating Material: Yellow Epoxy Polymer, UL 94 V-0

Round Pins: Copper alloy, tin plated

Max. Device Surface Temperature in Tripped State
125 °C

Operating / Storage Temperature
-40 °C to +85 °C (consider de-rating)

Humidity Ageing
+85 °C, 85 % R.H., 1000 hours, ± 5 % typical resistance change

Soldering Characteristics
Solderability per MIL-STD-202, Method 208E

Thermal Shock
MIL-STD-202F, Method 107G
+125 °C to -40 °C 10 times,

±10 % typical resistance change

Solvent Resistance
MIL-STD-202, Method 215F, no change

Marking
"P", voltage, amperage rating, lot number

Dimensions (mm)

Model	Fig.	A Max	B Max	C typ	D Min	E Max	Physical Lead	Characteristics Material	packaging bag	quantity ammo
HVR250P080C	1	5,8	10,9	5,5	4,7	5,1	0.65 dia	Sn/Cu	500	1500
HVR250P080U	1	5,0	9,0	3,8	4,7	5,1	0.65 dia	Sn/Cu	500	1500
HVR250P080CF	1	5,8	10,9	5,5	4,7	5,1	0.65 dia	Sn/Cu	500	1500
HVR250P110U	1	5,3	9,4	3,8	4,7	5,1	0.65 dia	Sn/Cu	500	1500
HVR250P120C	2	6,8	12,5	5,5	4,7	5,1	0.65 dia	Sn/Cu	500	1200
HVR250P120U	2	6,0	10,0	3,8	4,7	5,1	0.65 dia	Sn/Cu	500	1200
HVR250P120C-RA	2	6,8	12,5	5,5	4,7	5,1	0.65 dia	Sn/Cu	500	1200
HVR250P120C-RC	2	6,8	12,5	5,5	4,7	5,1	0.65 dia	Sn/Cu	500	1200
HVR250P120C-RF	2	6,8	12,5	5,5	4,7	5,1	0.65 dia	Sn/Cu	500	1200
HVR250P120C-R1	2	6,8	12,5	5,5	4,7	5,1	0.65 dia	Sn/Cu	500	1200
HVR250P120C-R2	2	6,8	12,5	5,5	4,7	5,1	0.65 dia	Sn/Cu	500	1200
HVR250P120C-R3	2	6,8	12,5	5,5	4,7	5,1	0.65 dia	Sn/Cu	500	1200
HVR250P120CT	2	6,8	12,5	5,5	4,7	5,1	0.65 dia	Sn/Cu	500	1200
HVR250P145C	2	6,8	12,5	5,5	4,7	5,1	0.65 dia	Sn/Cu	500	1200
HVR250P145U	2	6,0	12,5	3,8	4,7	5,1	0.65 dia	Sn/Cu	500	1200
HVR250P145C-RA	2	6,8	10,0	5,5	4,7	5,1	0.65 dia	Sn/Cu	500	1200
HVR250P145C-RB	2	6,8	12,5	5,5	4,7	5,1	0.65 dia	Sn/Cu	500	1200
HVR250P145CT	2	6,8	12,5	5,5	4,7	5,1	0.65 dia	Sn/Cu	500	1200
HVR250P180C	2	12,5	12,9	5,5	4,7	5,1	0.65 dia	Sn/Cu	200	1000
HVR250P180U	2	10,4	12,6	3,8	4,7	5,1	0.65 dia	Sn/Cu	200	1000
HVR250P180CF	1	12,0	13,2	5,5	4,7	5,1	0.65 dia	Sn/Cu	200	1000

Permissible continuous operating current is ≤ 100 % at ambient temperature of 20 °C (68 °F).

Model	I_{hold}	I_{Trip} (A)	$V_{max. ac}$ V_{int}/V_{op}^*	$I_{max.}$ (A)	max. time to trip (s @ A)	$P_{d max.}$ (W)	Resistance			Approvals
							$R_{min.}$ (Ω)	$R_{max.}$ (Ω)	$R_{I max.}$ (Ω)	
HVR250P080C	0.080	0.16	250/60	3	3.00 @ 0.35**	1.00	14.0	22.0	33	• •
HVR250P080U	0.080	0.16	250/60	3	3.00 @ 0.35**	1.00	15.0	22.0	33	• •
HVR250P080CFT	0.080	0.16	250/60	3	3.00 @ 0.35**	1.00	14.0	22.0	33	p •
HVR250P110U	0.110	0.22	250/60	3	0.75 @ 1.00	1.00	5.0	9.0	16	p •
HVR250P120C	0.120	0.24	250/60	3	1.50 @ 1.00	1.00	4.0	8.0	16	• •
HVR250P120U	0.120	0.24	250/60	3	1.00 @ 1.00	1.00	6.0	10.0	16	• •
HVR250P120C-RA	0.120	0.24	250/60	3	0.90 @ 1.00	1.00	7.0	9.0	16	• •
HVR250P120C-RC	0.120	0.24	250/60	3	0.85 @ 1.00	1.00	5.4	7.5	14	• •
HVR250P120C-RF	0.120	0.24	250/60	3	0.70 @ 1.00	1.00	6.0	10.5	16	• •
HVR250P120C-R1	0.120	0.24	250/60	3	0.80 @ 1.00	1.00	6.0	9.0	16	• •
HVR250P120C-R2	0.120	0.24	250/60	3	0.70 @ 1.00	1.00	8.0	10.5	16	• •
HVR250P120C-R3	0.120	0.24	250/60	3	1.00 @ 1.00	1.00	8.0	10.0	16	• •
HVR250P120CT	0.120	0.24	250/60	3	0.70 @ 1.00	1.00	7.0	12.0	16	• •
HVR250P145C	0.145	0.29	250/60	3	2.50 @ 1.00	1.00	3.0	6.0	14	• •
HVR250P145U	0.145	0.29	250/60	3	2.00 @ 1.00	1.00	3.5	6.5	14	• •
HVR250P145C-RA	0.145	0.29	250/60	3	2.50 @ 1.00	1.00	3.0	5.5	12	• •
HVR250P145C-RB	0.145	0.29	250/60	3	2.00 @ 1.00	1.00	4.5	6.0	14	• •
HVR250P145CT	0.145	0.29	250/60	3	2.00 @ 1.00	1.00	5.4	7.5	14	• •
HVR250P180C	0.180	0.65	250/60	3	21.00 @ 1.00	1.80	0.8	2.0	4	• •
HVR250P180U	0.180	0.65	250/60	10	15.00 @ 1.00	1.80	0.8	2.0	4	• •
HVR250P180CF	0.180	0.65	250/60	3	21.00 @ 1.00	1.80	0.8	2.2	4	p •

* V_{int} : Interrupt Voltage V_{op} : Operating Voltage(Vcd)
** typical value

NOTE:

I_{hold} = Hold current: maximum current device will pass without tripping in 20 °C still air.
 I_{trip} = Trip current: minimum current at which the device will trip in 20 °C still air.
 I_{max} = Maximum fault current device can withstand without damage at rated voltage (V_{max})

P_d = Power dissipated from device when in the tripped state at 20 °C still air.
 R_{min} = Minimum resistance of device in initial (un-soldered) state.
 $R_{I max}$ = Maximum resistance of device at 20 °C measured one hour after tripping for 20 s.
Caution: Operation beyond the specified rating may result in damage and possible arcing and flame.

Order Information	Qty.	Order-Number	Model	Packaging
-------------------	------	--------------	-------	-----------

Specifications are subject to change without notice.

No. HVR250

Average time-current curve

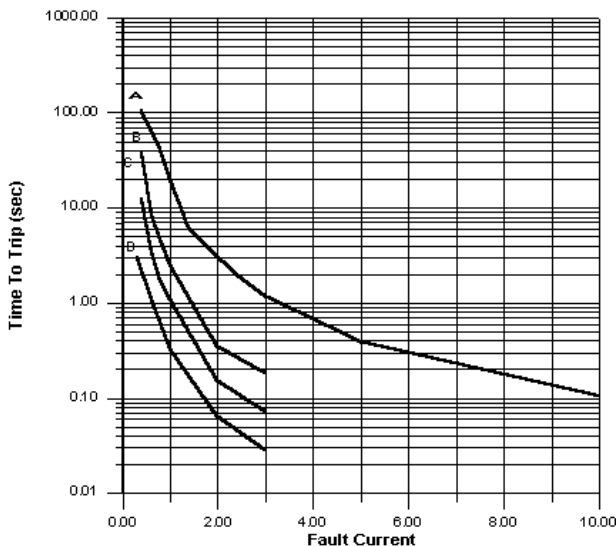

- A : HVR250P180C / HVR250P180F
- B : HVR250P145C
- C : HVR250P120C
- D : HVR250P080F

Agency Specification

Product	Lightning	Power Cross
HVR250P080F	ITU K.20/21/45 - 1.5 kV 10/700 μ s	ITU K.20/21/45 - 230 V ac, 10 Ω
HVR250P120C	ITU K.20/21/45 - 4 kV 10/700 μ s	ITU K.20/21/45 - 600 V ac, 600 Ω
HVR250P145C	ITU K.20/21/45 - 1.5 kV 10/700 μ s	ITU K.20/21/45 - 230 V ac, 10 Ω
HVR250P180C	ITU K.20/21/45 - 4 kV 10/700 μ s	ITU K.20/21/45 - 600 V ac, 600 Ω
HVR250P180F	Telcordia GR-974 - 1.0 kV 10/1000 μ s	Telcordia GR-974 - 283 V ac, 10 A

select a specific part number for each application based on the agency request

Part-numbering system

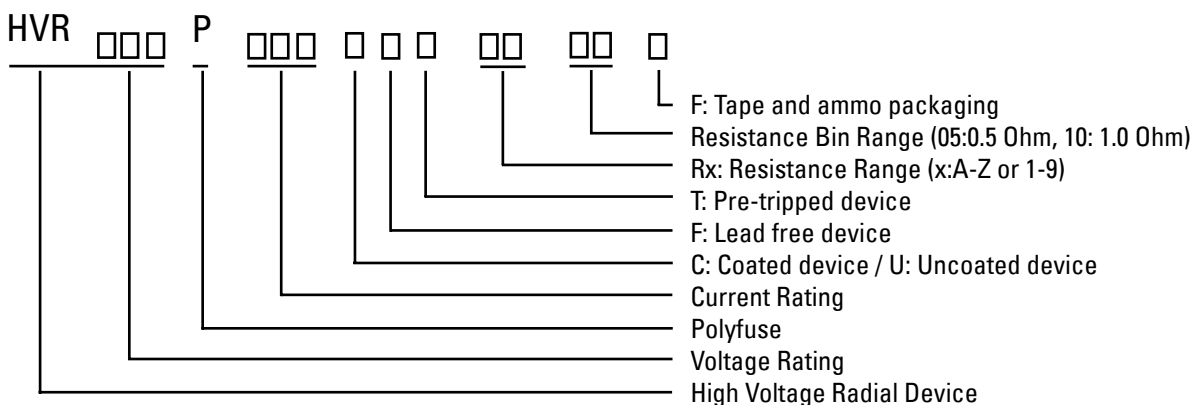

Thermal Derating Chart

Model	Ambient Operation Temperature - I _{hold} (A)								
	-40 °C	-20 °C	0 °C	23 °C	40 °C	50 °C	60 °C	70 °C	85 °C
HVR250P080C/U	0.12	0.11	0.09	0.08	0.06	0.05	0.05	0.04	0.03
HVR250P080CF	0.12	0.11	0.09	0.08	0.06	0.05	0.05	0.04	0.03
HVR250P110U	0.17	0.15	0.13	0.11	0.09	0.08	0.07	0.05	0.04
HVR250P120C/U	0.18	0.16	0.14	0.12	0.10	0.09	0.08	0.06	0.05
HVR250P145C/U	0.26	0.20	0.17	0.145	0.12	0.11	0.09	0.08	0.06
HVR250P180C/U	0.27	0.23	0.21	0.18	0.15	0.13	0.19	0.11	0.083
HVR250P180CF	0.28	0.23	0.21	0.18	0.16	0.13	0.10	0.11	0.083