

UV-2802 Single Beam Scanning UV/Visible Spectrophotometer **User Guide**



United Products Instruments Inc.

182-E, Ridge Road, Dayton, NJ 08810

U.S.A.

Tel: 732-274-1155

Fax: 732-274-1151

WWW.UNICOI.COM

Sales@unicoi.com

Contents

Safety	2
General	2
Electrical	2
Warning	2
Performance	3
Radio Interference	3
Introduction	3
Working Principle	4
Unpacking Instructions	4
Specifications	5
Installation	5
Operation	6
Prepare the Spectrophotometer	6
Description of keys	6
Turn on spectrophotometer	7
Basic operation.....	8
Analyse Sample	12
Basic Mode	12
Quantitative	15
WL Scan	20
Kinetics	25
DNA/Protein	28
Multi Wavelength	31
Setting and Calibration	33
Utility	33
Defined Tests	43
Appendix A	46
Appendix B	47
Appendix C	54

Safety:

The safety statements in this manual comply with the requirements of the HEALTH AND SAFETY AT WORK ACT, 1974.

Read the following before installing and using the instrument and its accessories. The UNICO UV-2802 should be operated by appropriate laboratory technicians.

General:

The apparatus described in this manual is designed to be used by properly trained personnel in a suitable equipped laboratory. For the correct and safe use of this apparatus it is essential that laboratory personnel follow generally accepted safe procedures in addition to the safety precautions called for in this manual.

The covers on this instrument may be removed for servicing. However, the inside of the power supply unit is a hazardous area and its cover should not be removed under any circumstances. There are no serviceable components inside this power supply unit. For UNICO UV-2802, avoid touching the high voltage power supply at all times.

Some of the chemicals used in spectrophotometry are corrosive and/or inflammable and samples may be radioactive, toxic, or potentially infective. Care should be taken to follow the normal laboratory procedures for handling chemicals and samples.

Electrical:

Before switching on the apparatus, make sure it is set to the voltage of the local power supply (see Installation).

The power cord shall be inserted in a socket provided with a protective earth contact. The protective action must not be negated by the use of an extension cord without a protective conductor.

Warning:

Any interruption of the protective conductor inside or outside the apparatus or disconnection of the protective earth terminal is likely to make the apparatus dangerous. Intentional interruption is prohibited.

Whenever it is likely that the protection has been impaired, the apparatus shall be made inoperative and be secured against any unintended operation.

NEVER touch or handle the power supply on UNICO UV-2802 due to the high voltage.

The protection is likely to be impaired if, for example, the apparatus

- Shows visible damage
- Fails to perform the intended measurements
- Has been subjected to prolonged storage under unfavorable conditions
- Has been subjected to severe transport stresses

Performance:

To ensure that the instrument is working within its specification, especially when making measurements of an important nature, carry out performance checks with particular reference to wavelength and absorbance accuracy. Performance checks are detailed in this manual.

Radio Interference:

For compliance with the EMC standards referred to in the EC Declaration of Conformity, it is necessary that only shielded cables supplied by us are used when connecting the instrument to computers and accessories.

Introduction:

The UNICO UV-2802 model spectrophotometer (Fig 1) is a single beam, general purpose instrument designed to meet the needs of the Conventional Laboratory, The UNICO UV-2802 model spectrophotometer is ideal for various applications, such as: Chemistry, Biochemistry, Petrochemistry, Environmental Protection, Food and Beverage Labs, Water and Waste Water Labs and other fields of quality control and research.

The UNICO UV-2802 model spectrophotometer incorporates a 320 × 240 dot matrix LCD display for photometric results, easy operation and wavelength range of 190nm to 1100nm. This instrument is ideal for measurements in the visible and ultraviolet wavelength region of the electromagnetic spectrum.

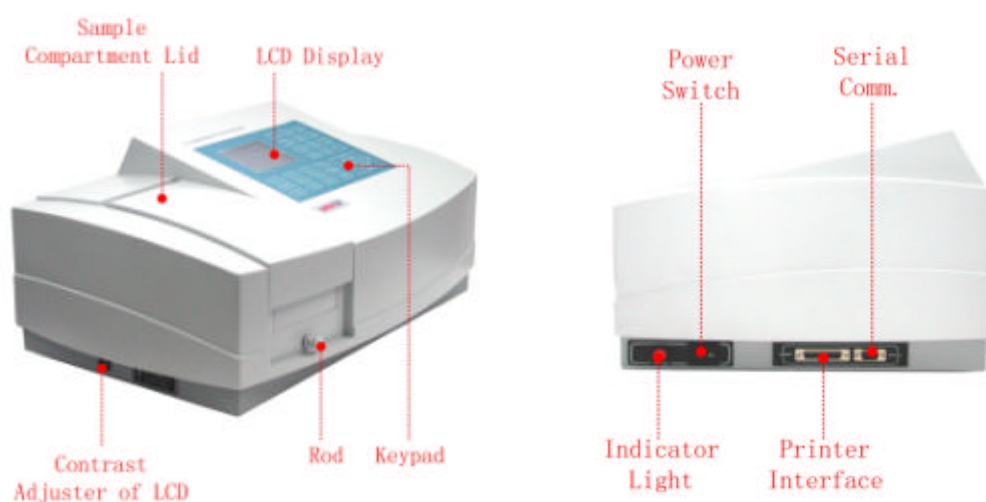

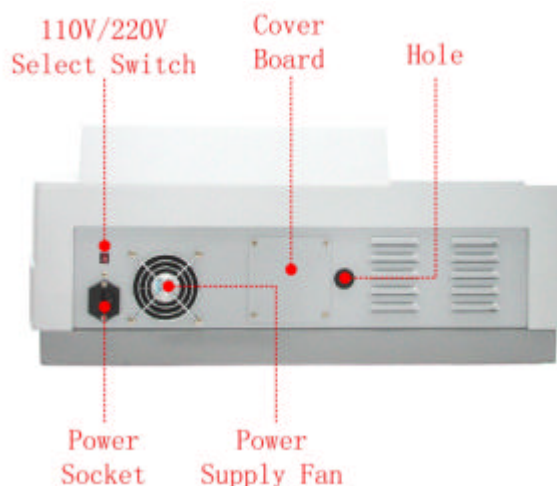

Fig1

Working Principle:

The spectrophotometer consists of five parts: 1) Halogen or deuterium lamps to supply the light; 2) A Monochromator to isolate the wavelength of interest and eliminate the unwanted second order radiation; 3) A sample compartment to accommodate the sample solution; 4) A detector to receive the transmitted light and convert it to an electrical signal; and 5) A digital display to indicate absorbance or transmittance. The block diagram (Fig 2) below illustrates the relationship between these parts.

Block diagram for the Spectrophotometer

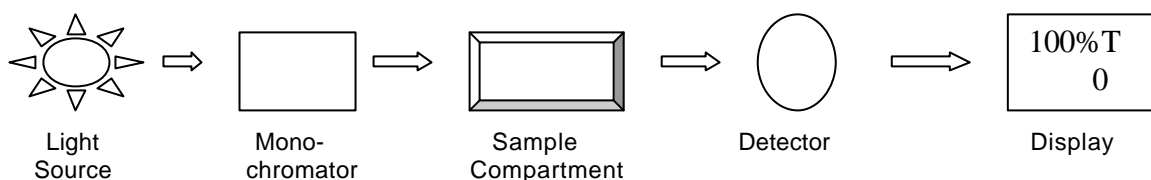

Fig 2

In your spectrophotometer, light from the lamp is focused on the entrance slit of the monochromator where the collimating mirror directs the beam onto the grating. The grating disperses the light beam to produce the spectrum, a portion of which is focused on the exit slit of the monochromator by a collimating mirror. From here the beam is passed to a sample compartment through one of the filters, which helps to eliminate unwanted second order radiation from the diffraction grating. Upon leaving the sample compartment, the beam is passed to the silicon photodiode detector and causes the detector to produce an electrical signal that is displayed on the digital display.

Unpacking Instructions:

Carefully unpack the contents and check the materials against the following packing list to ensure that you have received everything in good condition.

Packing List

<u>Description</u>	<u>Quantity</u>
• Spectrophotometer.....	1
• Mains Lead.....	1
• Cuvettes.....	Set of 4, glass
.....	Set of 2, quartz
• Dust Cover.....	1
• Manual.....	1

Specifications:

- Wavelength Range: 190-1100nm
- Spectral Bandpass: 4nm
- Wavelength Accuracy: $\pm 0.8\text{nm}$
- Wavelength Repeatability: $\pm 0.05\text{nm}$
- Stray Radiant Energy: $< 0.15\% @ 220\text{nm} \& 340\text{nm}$
- Photometric Range: 0-200%T, -0.3-.2.8A
- Noise: $< 0.001\text{A} @ 500\text{nm} \text{ } 0\text{A}$
- Drift: $< 0.002\text{A/h} @ 500\text{nm}$
- Power Requirements: AC 110V/60Hz or 220V/50Hz
- Dimensions: 550W x 420L x 270H
- Light Source: Tungsten Halogen/Deuterium
- Weight: 18kg

Installation:

1. After carefully unpacking the contents, check the materials with the packing list (page 4) to ensure that you have received everything in good condition.
2. Place the instrument in a suitable location away from direct sunlight. In order to have the best performance from your instrument, keep it as far as possible from any strong magnetic or electrical fields or any electrical device that may generate high-frequency fields. Set the unit up in an area that is free of dust, corrosive gases and strong vibrations.
3. Remove any obstructions or materials that could hinder the flow of air under and around the instrument.
4. Use the appropriate power cord and plug into a grounded outlet.
5. Turn on your UNICOUV-2802 model spectrophotometer. Allow it to warm up for 15 minutes before taking any readings. We suggest you then do the Calibrate System with the Search 656.1nm to set the wavelength to the deuterium lamp emission line.

NOTE:



This symbol means Caution, Risk of Danger. Refer to this Manual (see Appendix B – Lamp Replacement)

Operation:

Prepare the spectrophotometer

Fig 3 is the control panel. User can perform all operations by pressing the keys and all the results and operation information are displayed on the LCD.

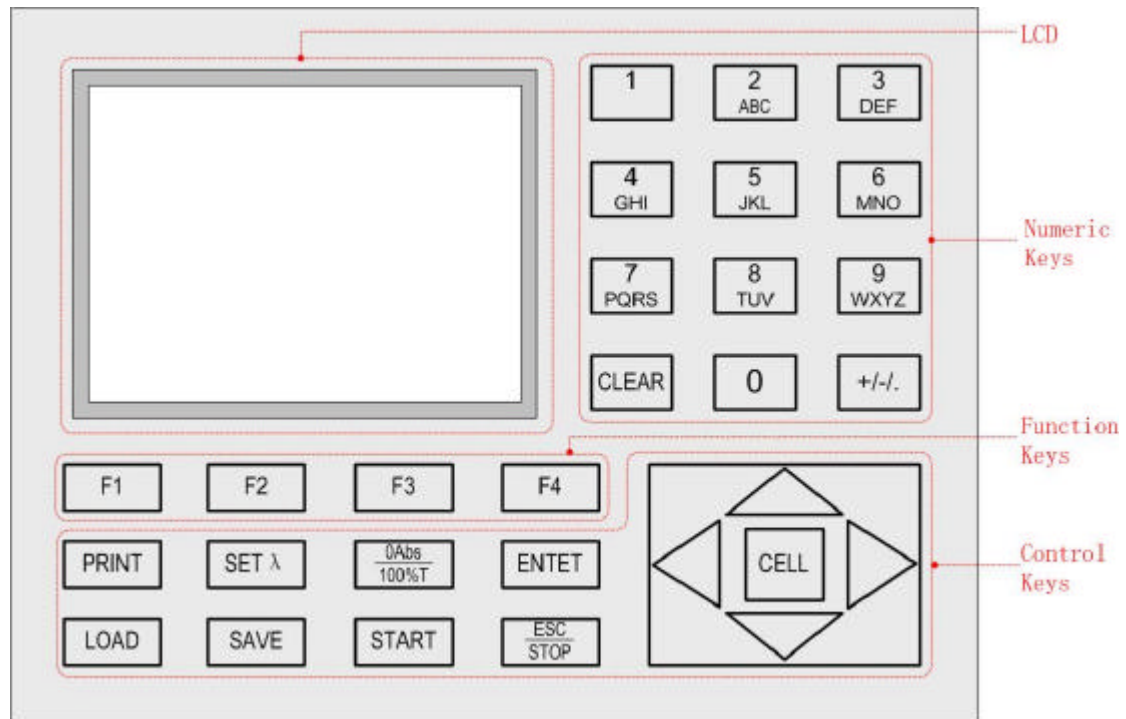

Fig 3

- Description of keys

- | | |
|------------------------|--|
| 【LOAD】 | Load data or curve saved before; |
| 【SAVE】 | Save data or curve; |
| 【SET λ】 | Set wavelength; |
| 【0Abs/100%T】 | Blank or scan the base line; |
| 【PRINT】 | Print test results or screen |
| 【START】 | Start testing or scanning sample; |
| 【ESC/STOP】 | Exit to previous screen or cancel the operation; |
| 【ENTER】 | Confirm the inputted data or selected item; Go into next setup or screen; |
| 【F1】 - 【F4】 | Function based on the information on the screen; |
| 【0】 - 【9】 | Input number or letter, consecutively press a numeric key to select a character; |
| 【+/-./】 | Input +,- or dot; |
| 【CLEAR】 | Clear all characters when you are inputting or clear curve displays on the screen; |
| 【<】 , 【>】 | Change "x" scale; Search point after scan; 【<】 clear a |

character;
 [] , [] Change “y” scale; Search peak after scan; Scroll items for selecting; Change capital/small letter last typed in; Browse the items for selection;

【CELL】 Set cell position.

• Turn on spectrophotometer

Turn on spectrophotometer by pressing the Power Switch (IO)(see Fig1). The instrument starts to initiate and the steps are as below:

*1.The instrument will check memory first (Fig 4), please wait or press any key to skip this step ,after positioning filter, auto-cell changer(if installed) and D2/W lamps,the screen display as Fig 4A. 15 minutes pass or press **【ESC】** , the screen display as Fig 5,Select “No”to skip to main menu(Fig 7) and select “Yes”(recommended) to calibrate system (Fig 6).The calibrating process include “get dark current”, “searching 656.1nm” and “check energy”.After finish the calibration system,go to main menu too (Fig 7).*

2.If the data in memory has been lost, the instrument will directly calibrate system without any choice for you.

3.If no auto-cell changer installed “cell #1” will disappear in Fig7

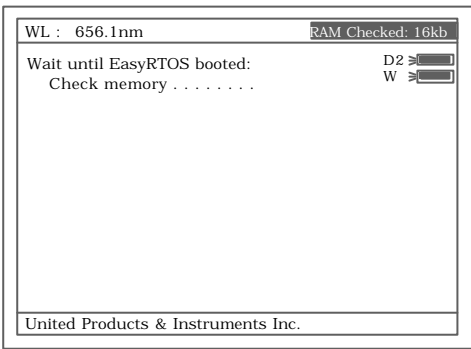

Fig 4

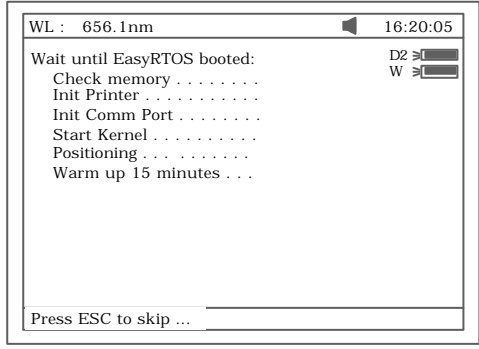

Fig 4A

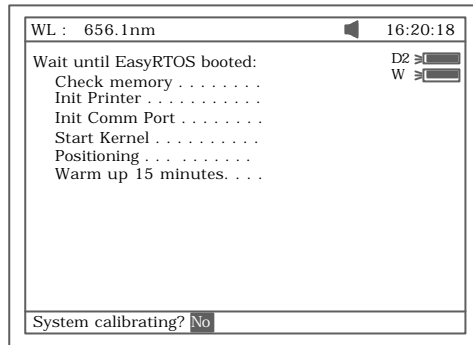

Fig 5

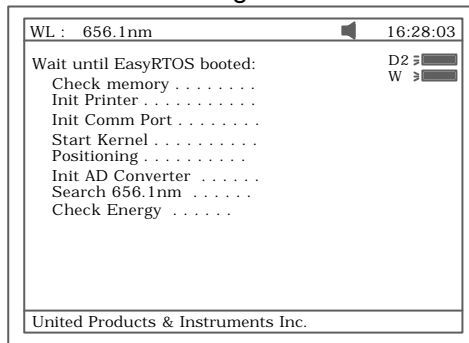

Fig 6

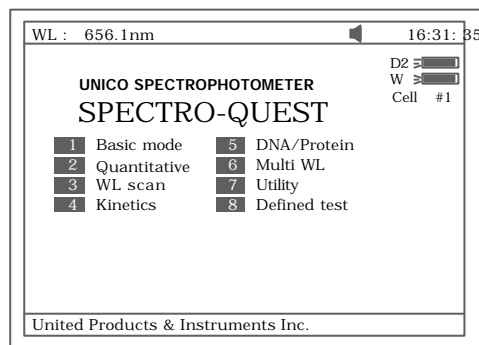

Fig 7

- Basic operation

Blank

- ✧ Push the blank cuvette into the lightpath.
- ✧ Press the key **【0Abs/100%T】** for blanking

Note:1. If the reference solution is too thick, “Energy Low...” will appear following the “Blanking...” on the screen (Fig 8). If “Energy too Low...” appears following the “Blanking...”, the test will be paused and “Warning...” will appear on the screen. (Fig 9).

2. If no automatic changer installed “cell #1” and “Max E” will disappear in Fig8

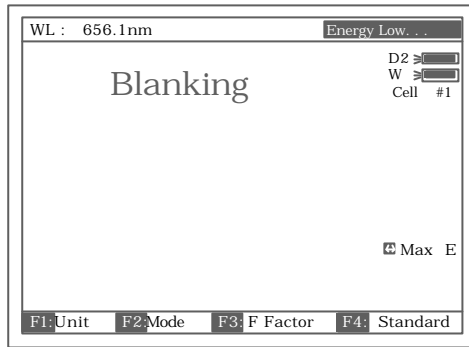

Fig 8

NOTE: 1. Blanking is automatic after a wavelength change

DO NOT OPEN SAMPLE COMPARTMENT LID DURING BLANKING.

2. The dark current don't be taken after power on, if you bypass the calibrating system. It is recommended to take the dark current after warm up. See page 38.

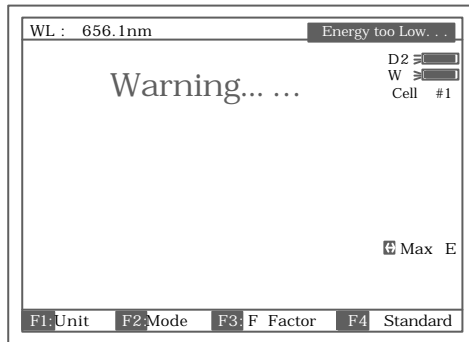

Fig 9

Set wavelength (Example: set wavelength in "Basic mode")

✧ Press **[SET]** (Fig 10).

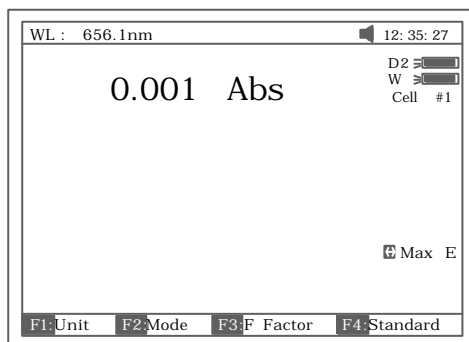

Fig 10

- ✧ Use numeric keypad to input wavelength (Fig 11).

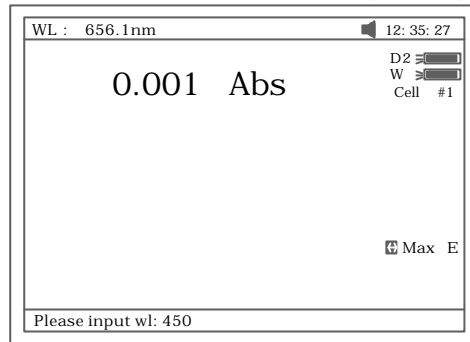

Fig 11

- ✧ Press **【ENTER】** to change the wavelength from 656.1nm to 450.0nm, and then blank; after blanking, the screen displays as Fig 12.

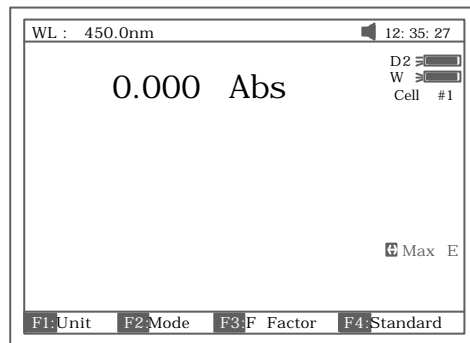

Fig 12

Load or delete data or curve (Take the “WL scan” test For example)

Press **【3】** in Fig.7 go into “WL scan”.After **【LOAD】** being pressed, the first file (ABC.wav) in memory will appear on the bottom line of screen. Shown as Fig 13. Press **【←】** or **【→】** to browse the files stored in memory. Then if :

1. The key **【ENTER】** be pressed, the file selected will be loaded and displays on the screen. Fig 14.
 Note(1). The file selected must match “WL scan” test’s type. if not , the “file type error...” will appear on the right of top line.
 (2). Different test has different file type. Refer to table 1 on page 12.
2. The key **【CLEAR】** be pressed the file selected will be deleted by selecting “Yes”.

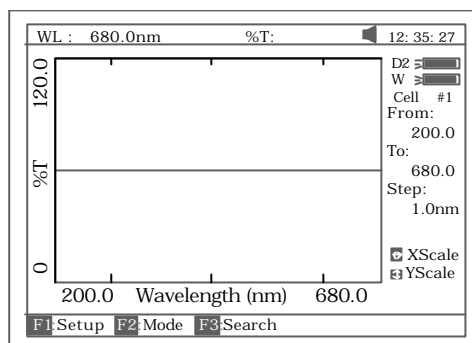

Fig 13

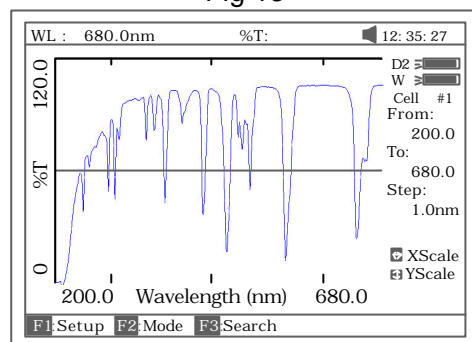

Fig 14

Table 1

Test	File Type
Quantitative Curve	***.fit
Quantitative Test Result	***.qua
WL Scan	***.wav
Kinetics	***.kin
DNA/Protein	***.dna
Multi WL	***.mul
WL Validity	***.wlv
Accu. Validity	***.phv

Save data or curve (Example: Save curve in “WL scan”)

- ✧ Press the key **【SAVE】** in Fig14 to save curve.
- ✧ Name the curve by pressing the numeric keypad (Fig 15), press the key **【ENTER】** to confirm.
 - . Note(1). Pressing numeric key continually to scroll characters and pressing **【 】**, **【 】** to alter capital letter to miniscule. Table 2 shows all characters built in.
 - (2) If the name already exists in memory, the warning “duplicated name, are you sure ? ” will appear . “ Yes ” for overwrite and “ No ” for Exit.
 - (3) The length of filename is less than 4.

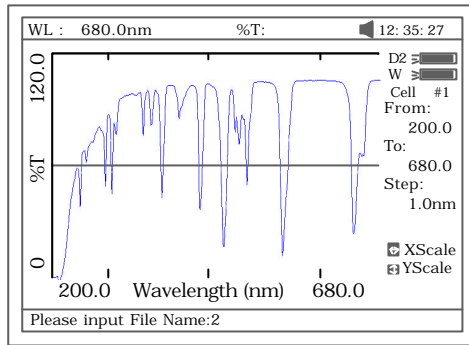

Fig 15

Table 2

key	representing	key	representing	key	representing
0	0,+,-,*,/,	1	1,#,?,:,	2	2,A,B,C,=
3	3,D,E,F,%	4	4,G,H,I,{	5	5,J,K,L,}
6	6,M,N,O,~	7	7,P,Q,R,S,	8	8,T,U,V,"
9	9,W,X,Y,Z	+/-/.	-.,,		

Print test report (For example: Print the report in “Basic mode”,Fig16)

Press the key **【PRINT】** to print the report (curve or data you have loaded or tested, Fig 17).

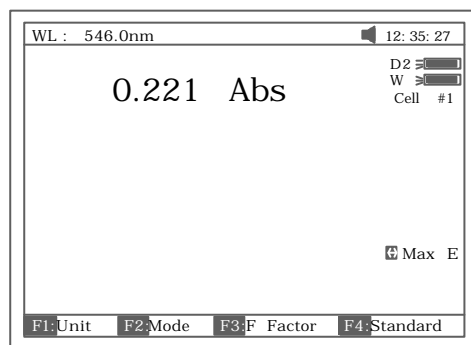

Fig 16

Basic Mode Test Report

Wavelength: 546.0nm
 Result: 0.221 Abs
 Date and Time: 25-06-2003 13:55:53

Fig 17

Before measurement

- Make a blank reference solution by filling a clean cuvette (or test tube) half full with distilled or de-ionized water or other specified solvent. Wipe the cuvette with tissue to remove the fingerprints and droplets of liquid.
- Fit the blank cuvette into the 4-cell linear changer and place the cuvette in the slot nearest you. For the UNICO UV-2802, push the changer so that

the cuvette is in the light path (Push the rod in). Close the lid.

Analyze Sample

For different user requirements, we have provided different test methods.

Basic Mode

Push the blank cuvette into the light path. In main menu (Fig7),press **【1】** to enter “Basic mode” test . After automatically blanking, it will display as Fig 18 (automatic changer installed) or Fig 19 (automatic changer uninstalled) and wait for the operator. **【ESC/STOP】** to exit.

Note: .If no automatic changer installed “cell #1” and “Max E” will disappear in Fig18

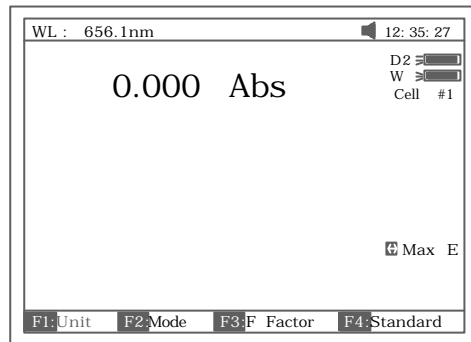

Fig18

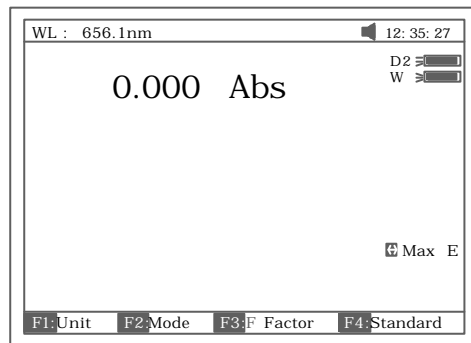

Fig19



Test

There are three modes (T%,Abs,conc/factor) for you to select by pressing **【F2】** to make choice.

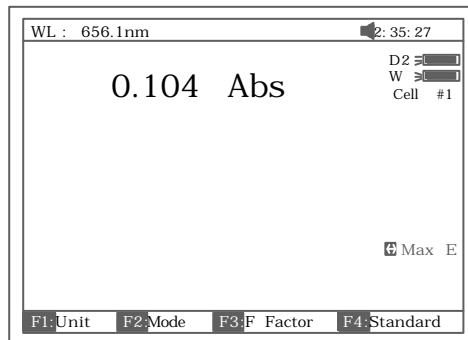

Fig 20

1. Abs mode

Push the blank cuvette into the light path. Press **【F2】** to select Abs mode, Press **【0Abs/100%T】** for Blanking, and then Push the sample into lightpath to take reading (Fig 20)

2. T% mode

The operation is the same as Abs test mode but pressing **【F2】** to select T% mode.

3. Conc/Factor mode

Press **【F1】** to select a concentration unit (Fig 21). If no unit is suitable for your test, please select the item "Other", press enter and input a new unit by pressing the numeric keypad (Fig 22).

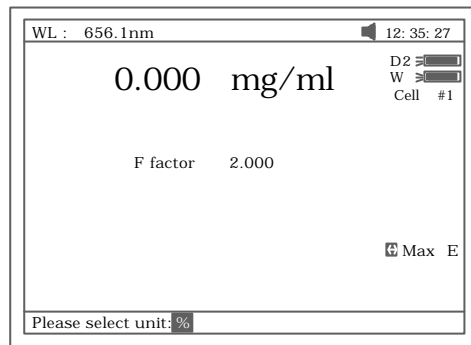

Fig 21

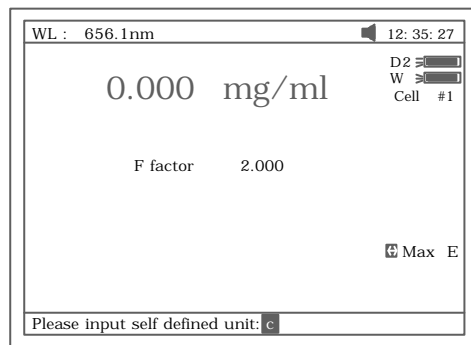

Fig 22

4. Push the blank cuvette into the light path and press **【0Abs/100%T】** for Blanking. There are now two choices for you to take:

4.1 Press **【F3】** to input known F value, Fig 23. Then push the sample into lightpath to take reading of concentration

4.2 Push sample of known concentration into the lightpath

Press **【F4】** to input known Conc value, Fig 24. Then push the sample into lightpath to take reading of concentration.

Note:1. You can select wavelength at any time by pressing **【SET】**. After your selection, instrument always blanks automatically.

2. If F value is more than 9999, the "out of range" will display on screen.

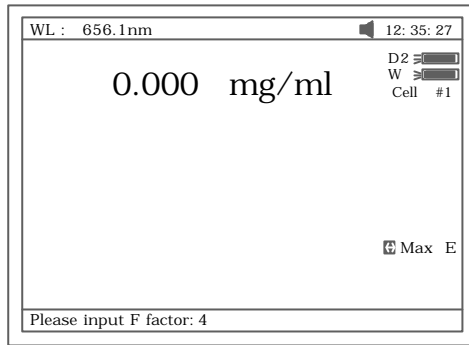

Fig 23

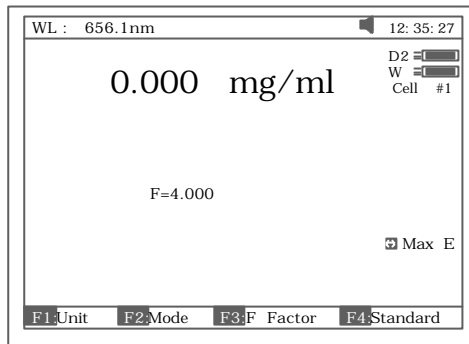

Fig 24

☺ Print Test Report
 Press **【PRINT】** to print test results (Fig 25).

Basic Mode Test Report

Wavelength: 546.0nm
 Result: 0.221 Abs
 Date and Time: 25-06-2003 13:55:53

Fig 25

Quantitative

Press **【2】** in Main Menu for “Quantitative” Test (Fig 26). Press **【ESC/STOP】** to exit.

Note: .If no automatic changer installed “cell #1” will disappear in Fig26.

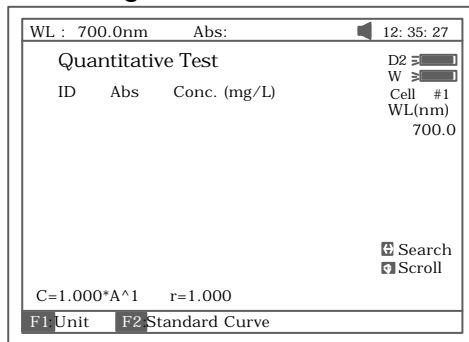

Fig 26

☺ How to operation

1. Press **【F1】** to select unit of concentration (Fig 27).

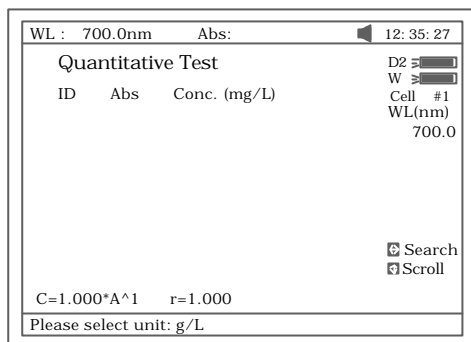

Fig 27

2 Press **【SET】** to select correction methods and enter the wavelength. There are three correction methods (single, Isoabsorbance and 3 point, Fig 28) .

Note: Please refer to the Appendix C for the correction method.

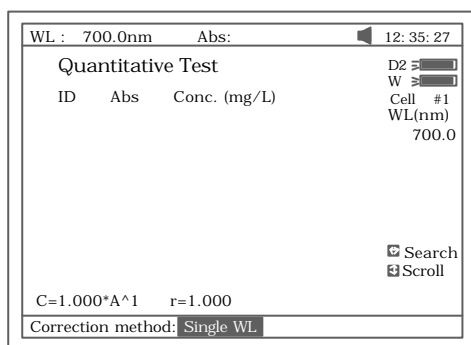

Fig 28

3. Press **【F2】** in Fig 26 for more items to select .See Fig 29.

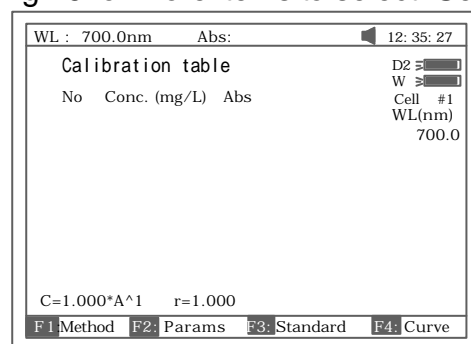

Fig 29

3.1 Press **【F1】** in Fig 29 to select fitting method. There are 4 methods for you to choose: Linear fit, linear fit through zero, square fit and cubic fit.

3.2 Press **【F2】** in Fig 29 to enter directly a known standard curve. Fig 29A.

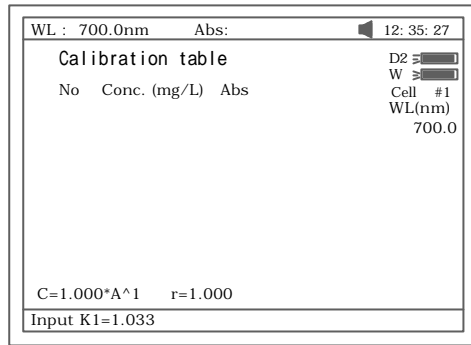

Fig 29A

The constants to be entered are depending on which fitting method selected. The table below lists their relation:

Fitting Method	Fitting Equation	constants
linear fit through zero	$C=K1 \times A$	$K1, r^*$
Linear fit	$C=K0+K1 \times A$	$K0, K1, r^*$
square fit	$C=K0+K1 \times A+K2 \times A^2$	$K0, K1, K2$
cubic fit	$C=K0+K1 \times A+K2 \times A^2+K3 \times A^3$	$K0, K1, K2, K3$

* r : regression co-efficients, default=1

3.3 Press **[F3]** in Fig 29 to establish a standard curve by measuring a group of standard samples. See Fig 30.

3.3.1 Enter standard concentrations of samples by pressing the Numeric keypad followed by **[ENTER]**. Press **[]** or **[]** to modify the inputted data Fig31. Press **[ESC/STOP]** to finish inputting and to exit Fig 32.

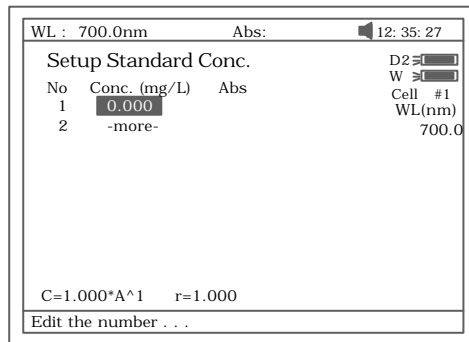

Fig 30

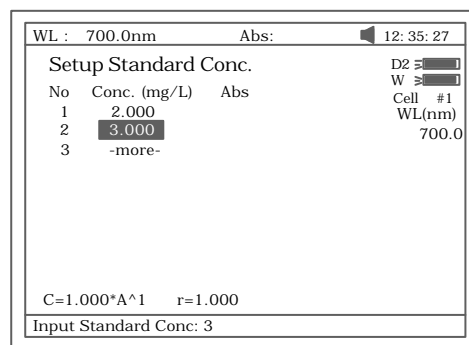

Fig 31

3.3.2 Push the blank cuvette into the light path, press **【0Abs/%100T】**, the instrument will step to the wavelength and blank. See Fig 32.

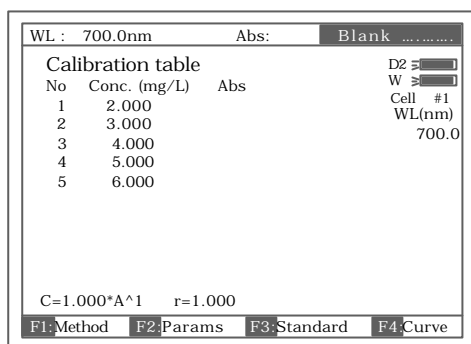

Fig 32

3.3.3 Pull the first sample cuvette of known concentration into the light path, Press the key **【START】** to get values of standard curve one by one (Fig 33).

Note: If auto-cell changer is installed, the vary samples are measured by pressing **【CELL】** following numbers(1-8) and pressing **【ENTER】** to confirm.

3.3.4 Press **【F4】** to draw the curve. You can get a different curve by pressing **【F1】** to select a different fitting method. See Fig 34-Fig37.

For linear fits, “r” represent fitting coefficient of linear regression. $r=1$ is best fitting, usually “r” is very close to 1.

Note: If there are few standard samples, it is not suitable for selecting square fitting, especially cubic fitting, otherwise invalid fitting result will be obtained.

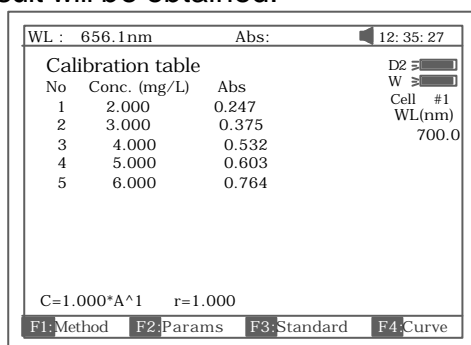

Fig 33

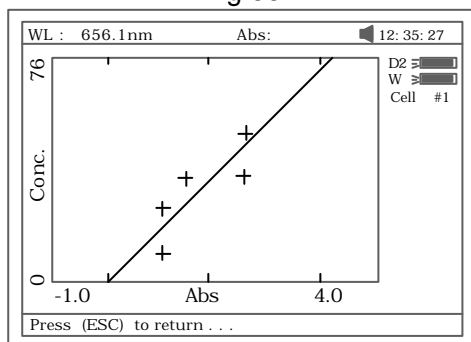

Fig 34 linear through zero fit

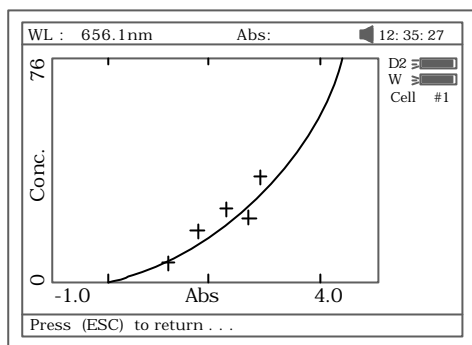

Fig 35 square fit

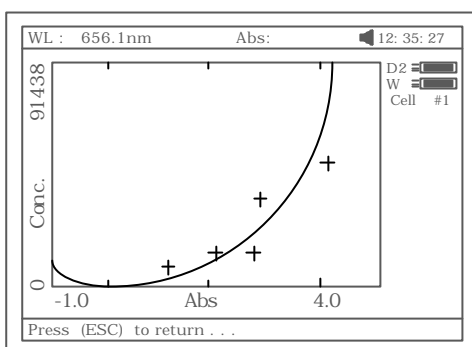

Fig 36 cubic fit

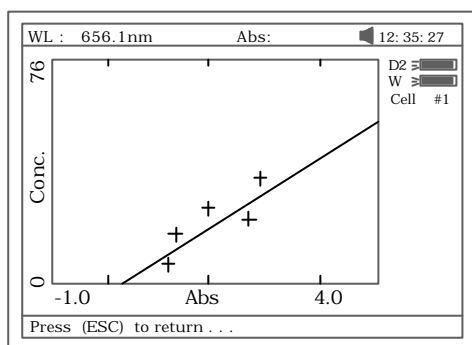

Fig 37 linear fit

3.3.5 Press **【SAVE】** to save calibration if required

3.3.6 Press **【ESC/STOP】** to exit

4. Quantitative Test

Before test, the standard curve must be obtained. There are three ways for you to obtain it (a, b or c).

- Standard curve built up and saved in the instrument.
In Fig 33 press **【Load】** and then press **【】** or **【】** to select the file with type *****.fit**. At last press **【ENTER】** to confirm.
- Known standard curve, which is not saved in the instrument.
See 3.2. For Fig 29 enter a known standard curve directly.
- Use the standard samples for the test. First the standard curve must be established using the method shown in 3.3.
Note: All sample results must be taken in screen Fig26.

- 4.1 Push the blank cuvette into the light path and press **【0Abs/100%T】** for blanking.
- 4.2 Pull the sample cuvette into the light path, press the key **【START】**, the results will be displayed on the screen (Fig 38).

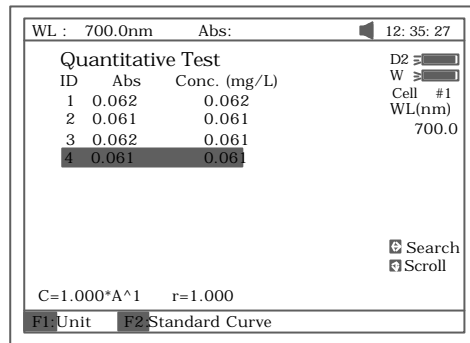

Fig 38

- 4.3 If there is more than one sample, repeat step 4.2 for the next sample
- 4.4 Press **(SAVE)** to save the results and fitting parameters

☺ Print Test Report

Press the key **【PRINT】** to print the test report (Fig 39).

```

Quantitative Test Report

File Name:
Date and Time: 25-06-2003 13:54:32

No   546.0nm Abs(eff)  C(mg/L)
1    0.212   0.212    3.315
2    0.212   0.212    3.321
3    0.000   0.212    3.315

Fitting Params:C= 15.64*A^1  r= 0.105

```

Fig 40

WL Scan

Press **【3】** in main menu for “WL Scan” test (Fig 41). **【ESC/STOP】** to exit.

To load a previous curve, press **【LOAD】** and select a previously stored curve (.wav)

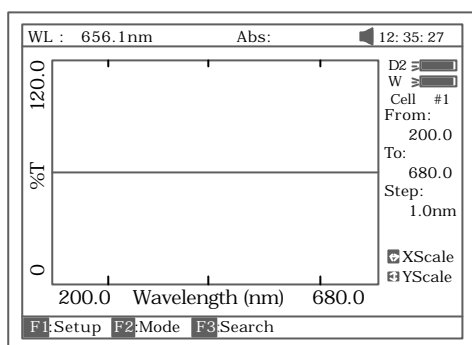

Fig 41

☺ Scan sample

1. Press **【F1】** to setup, input the start wavelength, and end wavelength by pressing the numeric keypad (Fig 42). Note: The UV-2802 scans from high to low wavelength. Browse and select the items of scan step and scan speed by pressing **【↑】** or **【↓】**.

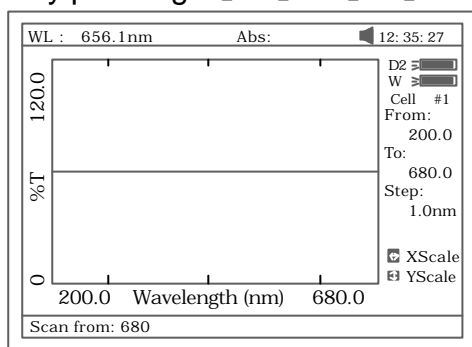

Fig 42

Note: “Scan step” allows the selection of 0.1nm, 0.2nm, 0.5nm, 1nm, 2nm and 5nm. “Scan speed” allows the selection of “HI”, “MEDIUM” and “LOW”. For survey scan we suggest 5nm, HI. For detailed scan we suggest 0.5nm, HI

2. Press **【F2】** to select the test mode, “Abs”, “%T” or “E” (Fig 43).

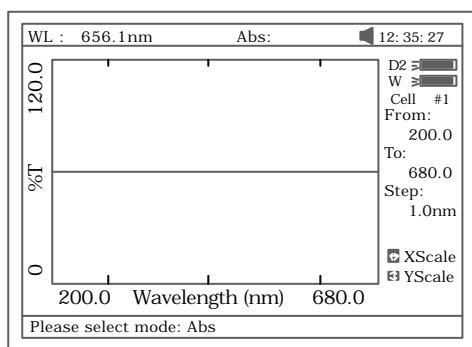

Fig 43

3. Push the blank cuvette into the light path, press **【0Abs/100%T】** to scan the base line (Fig 44). Press the key **【ESC/STOP】** to stop

scanning;

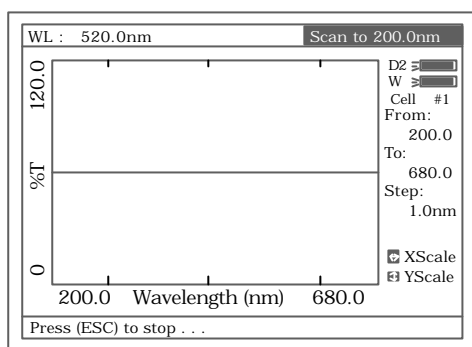

Fig 44

4. Pull the sample cuvette into the light path, press **【START】** to scan the sample (Fig 45) **【ESC/STOP】** to stop scanning. When scan has finished the beeper beeps 3 times (Fig 46).

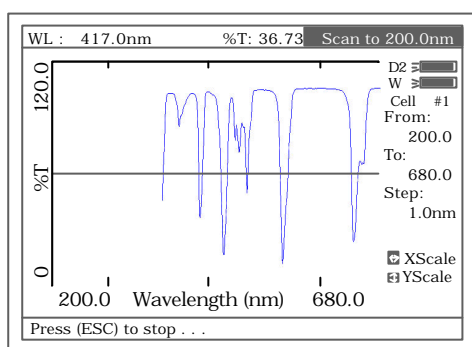

Fig 45

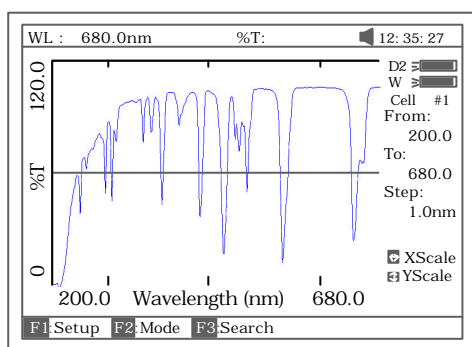

Fig 46

5. If you want to change the scale, press **【 < 】** or **【 > 】** to change “x” scale (Fig 47), input upper limit and lower limit by pressing the numeric keypad. To change “y” scale press **【 】** or **【 】**. After these inputs the instrument will redraw the curve (Fig 48).

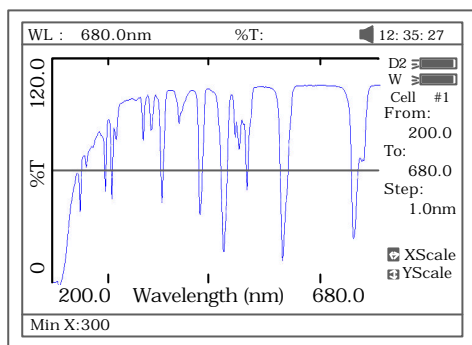

Fig47

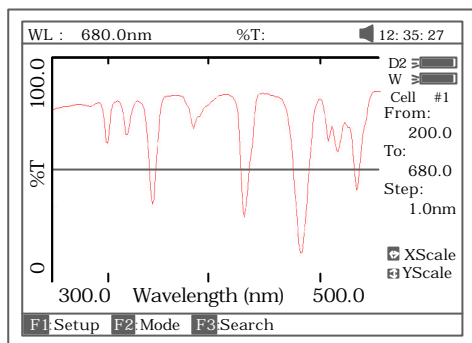

Fig 48

- 6 Press **[F3]** to search the Abs/%T value of the scan. There are two ways for you to search (Fig 49).

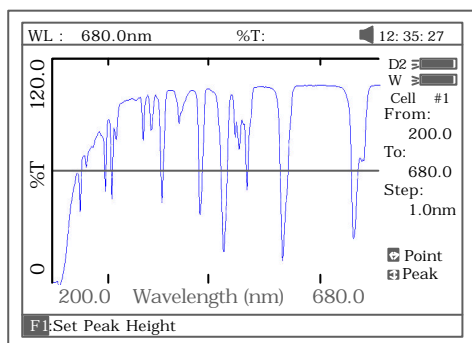

Fig 49

- a) *Peak to peak, press **[F1]** to set "peak height" and input value by pressing the numeric keypad (Fig 50). Press **[]** to search the peak from left to right and press **[]** to search from right to left. The value of every peak found will be displayed on the screen one at a time (Fig 51).*

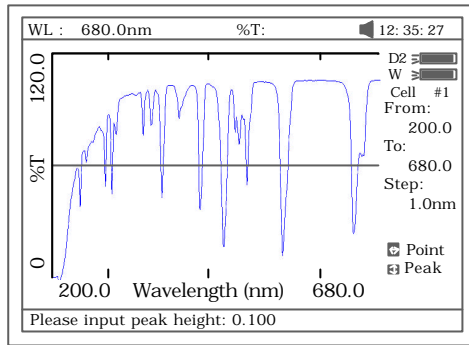

Fig 50

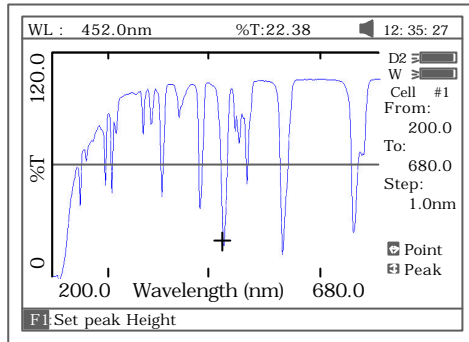

Fig 51

b) *Point to point, Press **[>]** to search the point from left to right and press **[<]** to search from right to left. The search step interval is the same as the scan step. The value of every point searched will be displayed on the screen.*

☺ Save Curve

Press **[SAVE]** to save the curve. Note: Load/Save requires the first scan display page Fig. 48. Press **ESC** if in Search to return to the required page

☺ Print Test Report

Press **[PRINT]** to print the curve you have loaded or scanned (Fig 52).

Note: The report always is printed in Fig 46

Wavelength Scan Test Report

File Name:
Date and Time: 25-06-2003 13:47:54
Scan From: 680.0nm
Scan To: 200.0nm
Scan Step: 1.0nm
Peak Height: 0.030Abs

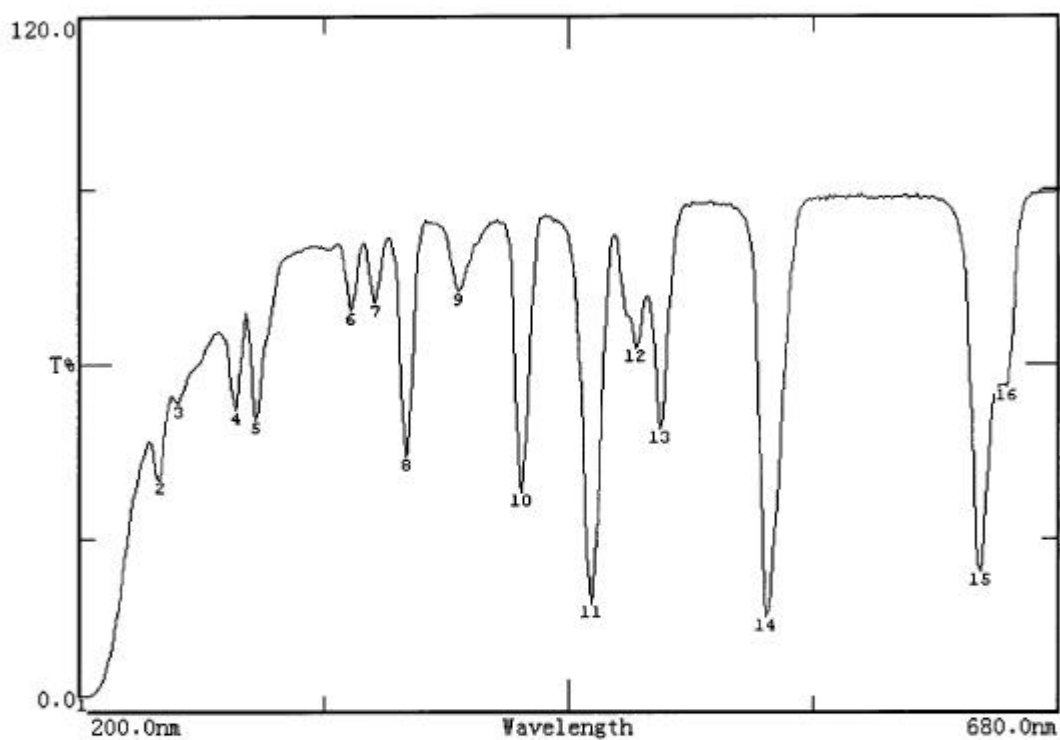

Peak list:

No.	Wavelength(nm)	Abs	T%
1	202.0	1.585	2.60
2	240.0	0.397	40.08
3	249.0	0.274	53.18
4	277.0	0.285	51.93
5	287.0	0.298	50.30
6	333.0	0.161	68.98
7	345.0	0.154	70.19
8	360.0	0.357	43.95
9	386.0	0.141	72.26
10	417.0	0.422	37.83
11	451.0	0.731	18.58
12	473.0	0.205	62.38
13	485.0	0.313	48.61
14	537.0	0.790	16.22
15	641.0	0.621	23.95
16	654.0	0.252	55.93

Fig 52

Kinetics

Press **[4]** in main menu for "Kinetics" (Fig 53). **[ESC/STOP]** to exit.
To load a previous kinetics result, press **(LOAD)** and select a previously stored result (.kin)

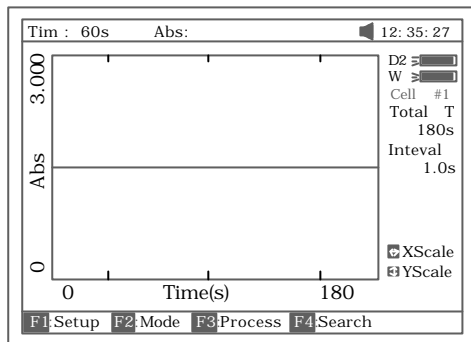

Fig 53

☺ Test

1. Press **【F1】** to set “Total Time”, ”Delay Time”, ”Time interval”, and input the value by pressing the numeric keypad (Fig 54).

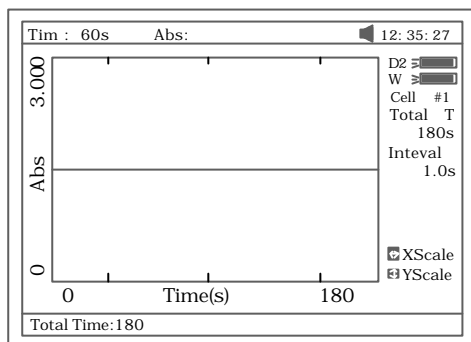

Fig 54

2. Select the test mode (“Abs” or “%T”) by pressing **【F2】** (Fig 55).

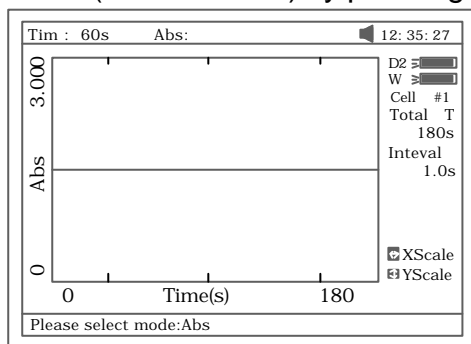

Fig 55

3. Set wavelength by pressing **【SET】**. Pull the blank cuvette into the light path, press **【0Abs/100%T】** for blanking
4. Pull the sample cuvette into the light path, press **【START】** to scan the sample. After the delay time, the beeper beeps 3 times and time -scan starts. At the end of the time-scan, the beeper also beeps 3 times (Fig 56);

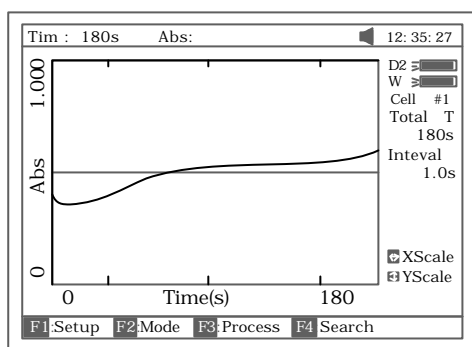

Fig 56

- Press **[F3]** to process the data, and enter "Begin Time", "End Time" and "Factor" (Fig 57) and the value in I.U. will be calculated and displayed (Fig 58). The average straight line between the Begin Time and End Time will be calculated. The gradient of this line gives the rate of change of ?A/min.

Note: I.U.=Factor × A/min

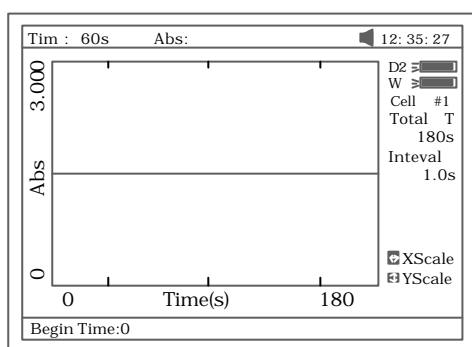

Fig 57

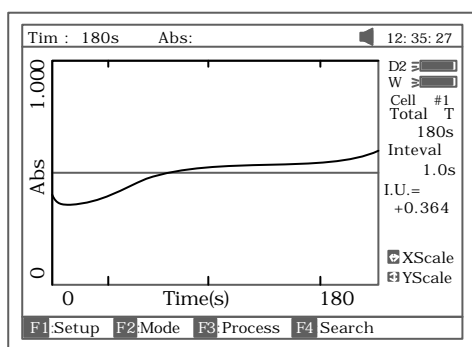

Fig 58

- If you want to change the scale, please refer to step 5 of "WL scan".
- Press **[F4]** to search the Abs/%T value in relation to the time axis. Search point to point by pressing the key **[<]** or **[>]**. Please refer to step 6 of "WL scan".

☺ Save Curve

Press the key **【SAVE】** to save curve. Note: Load/Save requires the first kinetics display page Fig. 56. Press **ESC** if in Search to return to the required page.

☺ Print Test Report

Press the key **【PRINT】** to print the curve you have loaded or scanned (Fig 59).

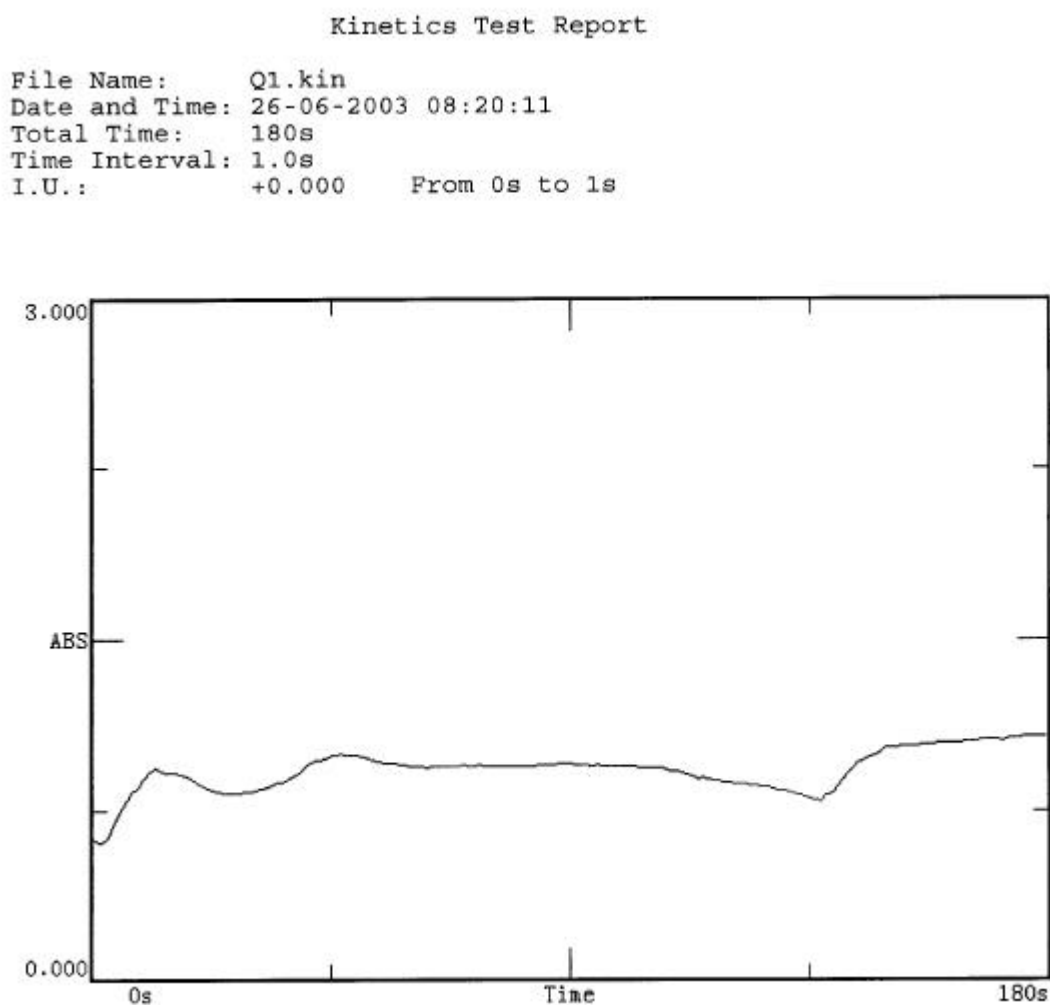

Fig 59

DNA/Protein

Press **【5】** in main menu for "DNA/Protein" (Fig 60). **【ESC/STOP】** to exit.
Note: The algorithm of the test refer to Appendix A please.

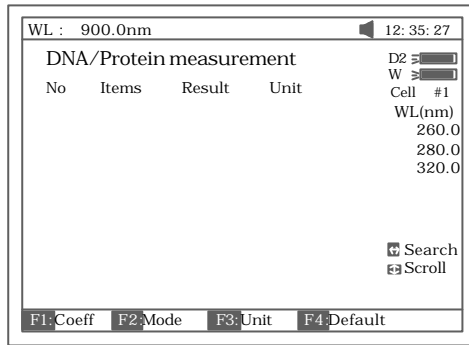

Fig 60

To load previous DNA results, press **(LOAD)** and select a previously stored result (.dna)

☺ Test

1. To use a simpler or different algorithm, you can enter your own values for f1-f4. Press **[F1]** to set f1-f4. Input the value by pressing the numeric keypad (Fig 61).

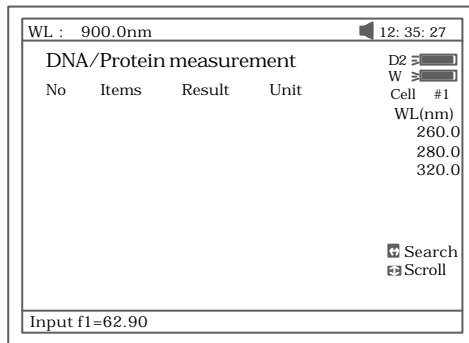

Fig 61

2. Press **[F2]** to select test mode. "Absorbance difference 1" is for testing at the wavelength 260nm,280nm and 320nm (optional),and the "Absorbance difference 2" is for testing at the wavelength 260nm,280nm and 320nm (optional, Fig 62). Then select with/without reference. If selected with reference (no), the A ref. will be "0" (Fig 63).

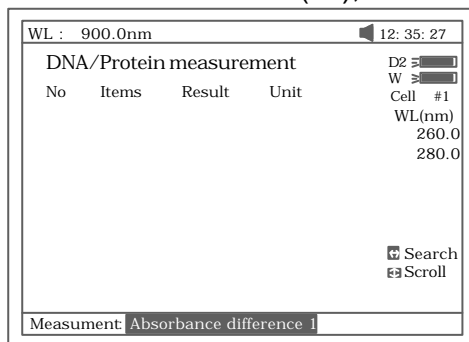

Fig 62

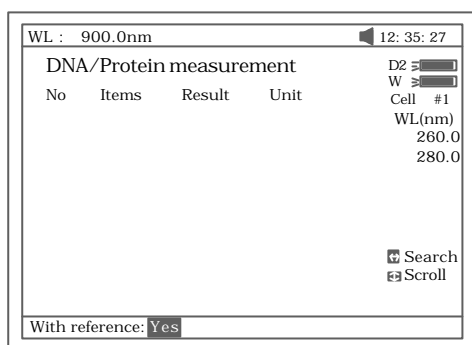

Fig 63

3. Press **【F3】** to select the unit of concentration (Fig 64).

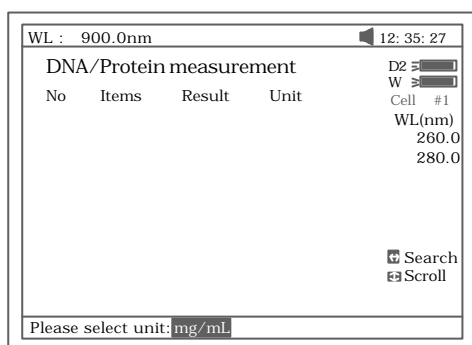

Fig 64

4. Push the blank cuvette into the light path, then press **【0Abs/100%T】** for blanking .
5. Pull the sample cuvette into the light path, press **【START】** to test the sample. The test result will be displayed on the screen (Fig 65).

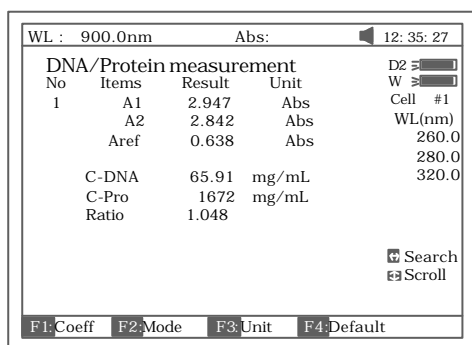

Fig 65

6. If there is more than one sample, repeat step 5 for the next sample.
7. Press the key **【 <)】** or **【 > 】** for searching. Input the sample number (Fig 66), the result will be displayed on the screen. Press the key **【 】** or **【 】** to browse the test results one by one.

WL : 900.0nm		Abs:		12: 35: 27	
DNA/Protein measurement					
No	Items	Result	Unit	D2	W
1	A1	2.947	Abs	Cell #1	WL(nm)
	A2	2.842	Abs	260.0	280.0
	Aref	0.638	Abs	320.0	
	C-DNA	65.91	mg/mL		
	C-Pro	1672	mg/mL		
	Ratio	1.048			
<input type="checkbox"/> Search <input type="checkbox"/> Scroll					
Search sample:3					

Fig 66

☺ Recall the default

Press the key **【F4】** to recall the default of the f1-f4.

☺ Save Data

Press the key **【SAVE】** to save data.

☺ Print Test Report

Press the key **【PRINT】** to print the test result (Fig 67).

DNA / Protein Test Report

File Name:

Date and Time: 26-06-2003 09:16:33

No	260.0nm	280.0nm	320.0nm	C-DNA	C-Pro	Ratio
1	0.226	0.212	0.102	3.825	76.60	1.127
2	0.226	0.213	0.102	3.803	79.32	1.113

Unit:ug/mL

Fig 67

Multi Wavelength

Press **【6】** in main menu for "Multi WL" (Fig 68). **【ESC/STOP】** to exit.

WL : 900.0nm		Abs:		12: 35: 27	
Multi Wavelength Test					
No	WL(nm)	Abs	D2	W	Cell #1
	500.0		1 WL		
<input type="checkbox"/> Search <input type="checkbox"/> Scroll					
F1:WL setup F2:Mode					

Fig 68

To load previous Multi Wavelength results, press **(LOAD)** and select previously stored results (.mul)

☺ Test

1. Press **【F1】** to setup a group of wavelengths for testing by pressing the numeric keypad followed by **【ENTER】**. (`) or () to modify the inputted data Fig. 69. Press **【ESC/STOP】** to finish setup and exit.
Note: It is recommended to enter the highest wavelength first.

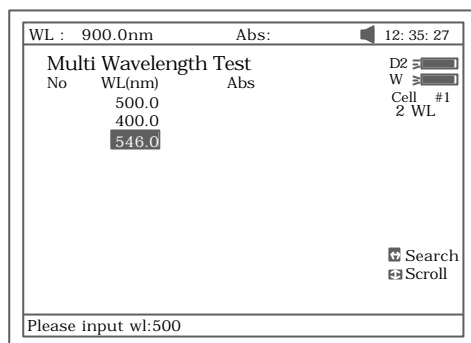

Fig 69

2. Press **【F2】** to select mode (Fig 70).

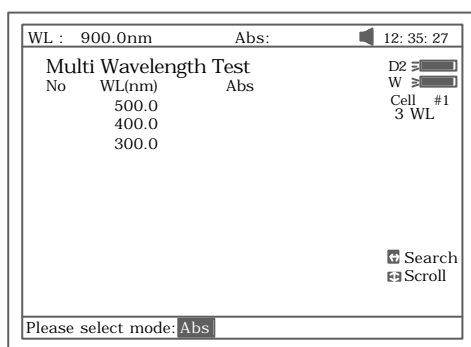

Fig70

3. Push the blank cuvette into the light path, then press **【0Abs/100%T】** for Blanking .
4. Pull the sample cuvette into the light path, press **【START】** to test. The test results will be displayed on the screen (Fig 71).

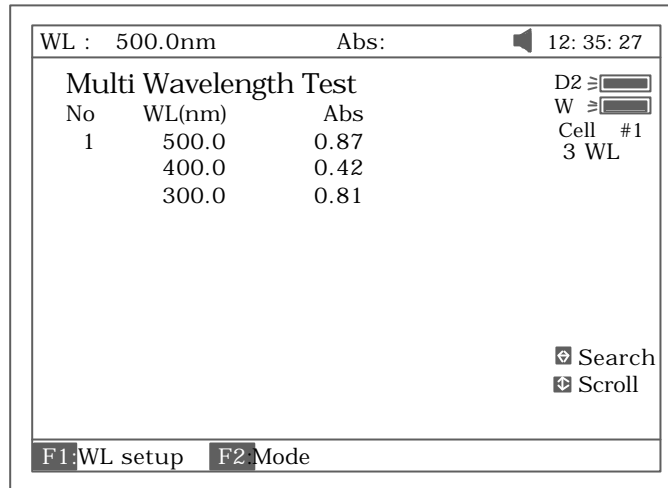

Fig 71

- If there is more than one sample, repeat step 4 for the next sample.
Note: When the test has finished, the wavelength will go to the first WL.
- Press [<] or [>] for searching. Input the sample number, the result will be displayed on the screen. Press [] or [] to browse the test results one by one.

☺ Save Data

Press [**SAVE**] to save data.

☺ Print Test Report

Press [**PRINT**] to print the test results (Fig 72).

```

Multi-Wavelength Test Report

File Name:      M1.mul
Date and Time: 26-06-2003 09:25:16

No  300.0nm  400.0nm  500.0nm
1   0.107   0.074   0.054
2   0.106   0.073   0.055
3   0.106   0.072   0.054

Unit:Abs

```

Fig 72

Setting and Calibration

Utility

Press [**7**] in Main menu for "Utility" (Fig 73). [**ESC/STOP**] to exit.

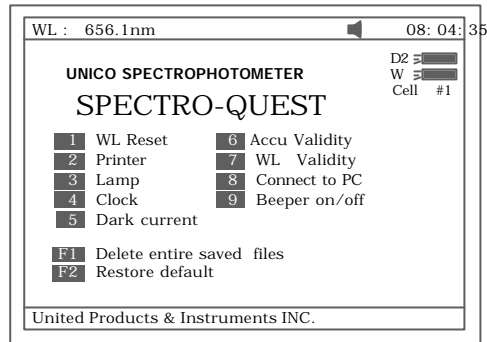

Fig 73

☺ WL Reset

Press **【1】** to reset wavelength (Fig74).

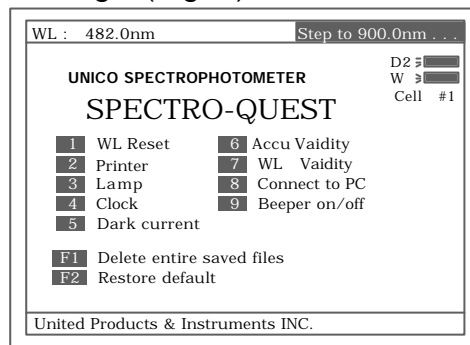

Fig 74

☺ Printer

Press **【2】** to set printer (Fig 75). **【ESC/STOP】** to exit.

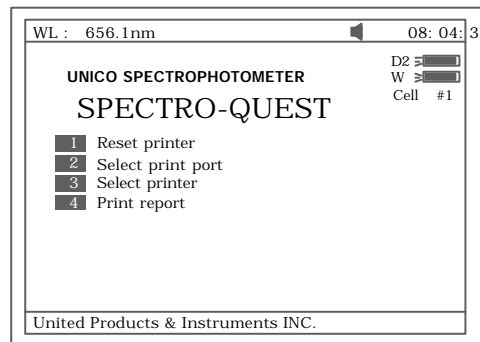

Fig 75

1. Press **【1】** in Fig 75 to Reset Printer.
2. Press **【2】** in Fig 75 to select print port (LPT or Comm., Fig 76).

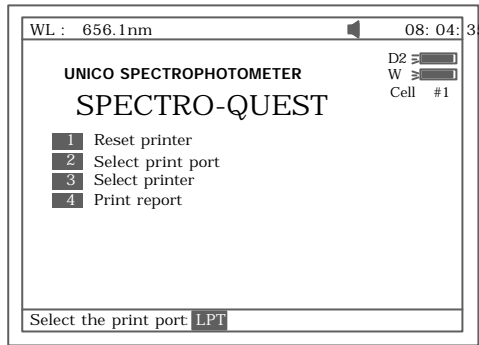

Fig 76

3. Press **【3】** in Fig 75 to select printer (HP PCL (1 colour cartridge), PCL (black mode), Epson ESC/P or Epson/P2 or above, Fig77).

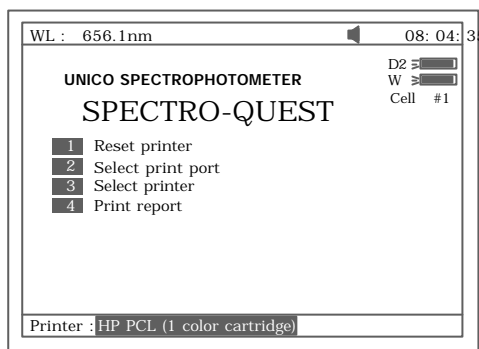

Fig 77

4. Press **【4】** in Fig 75 to select print mode. If you select “Print screen” mode, a little icon will be displayed on the top line of the screen (Fig 78), if you select “Print report” mode, the little icon will disappear.

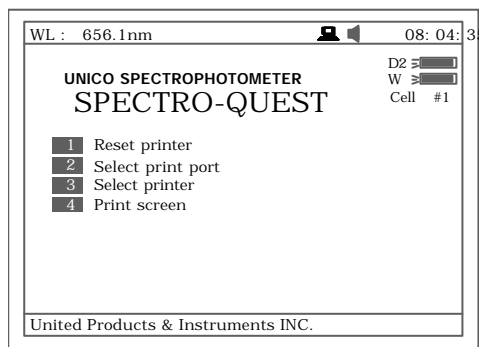

Fig78

☺ Lamp

Press **【3】** to set lamp (Fig 79). **【ESC/STOP】** to exit.

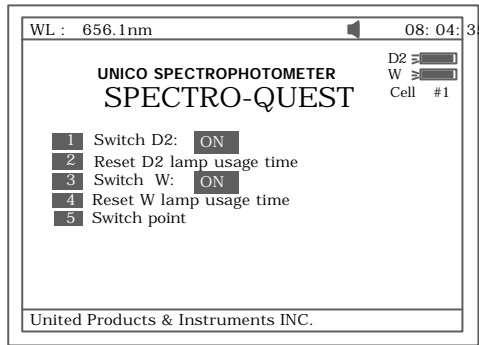

Fig 79

1. Press **【1】** in **Fig 79** to switch on/off D2. Fig 80.

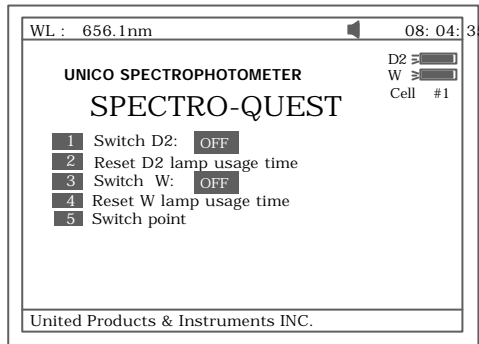

Fig 80

2. Press **【2】** in **Fig 79** to reset usage time of D2(Fig 81). Press **【Y】** or **【N】** to select “Yes” or “No”, and then press **【ENTER】**.

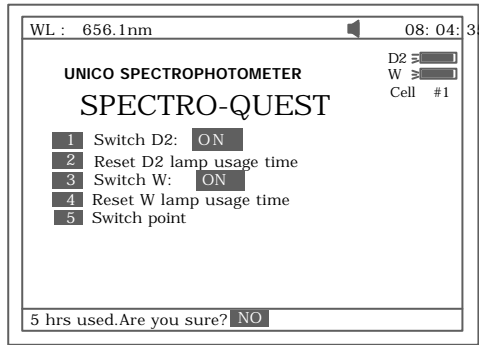

Fig 81

3. Press **【3】** in **Fig 79** to switch on/off W. The indication is also on the top right corner of the screen (Fig 82).

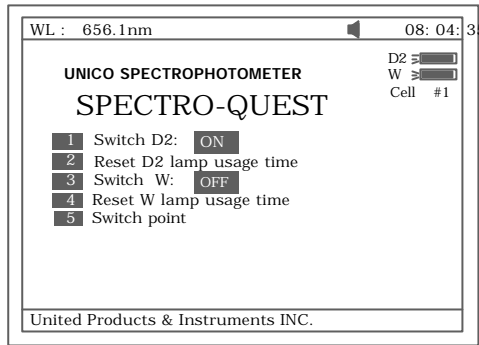

Fig 82

4. Press **【4】** in Fig 79 to reset usage of W (Fig 83). Press **【** **】** or **【** **】** to select “Yes” or “No”, and then press **【ENTER】** .

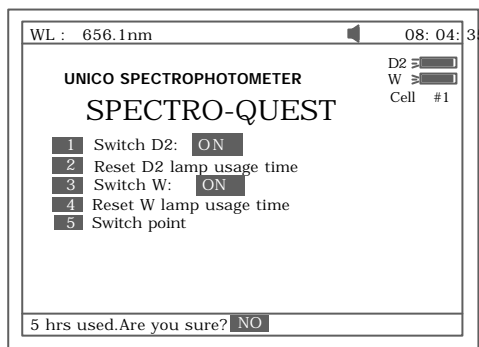
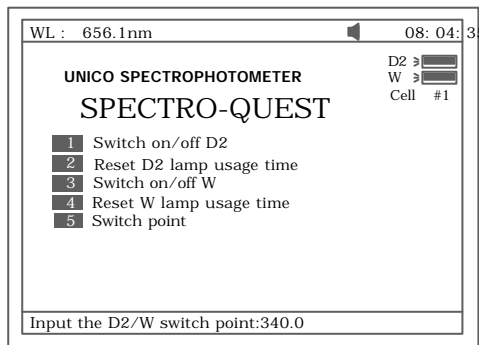

Fig 83

5. Press **【5】** in Fig 79 to set the switch usage point of D2 and W lamp (Fig 84).



84

☺ Clock

- Press **【4】** In Fig73 to set the display mode and modify the clock (Fig 85). **【ESC/STOP】** to exit.

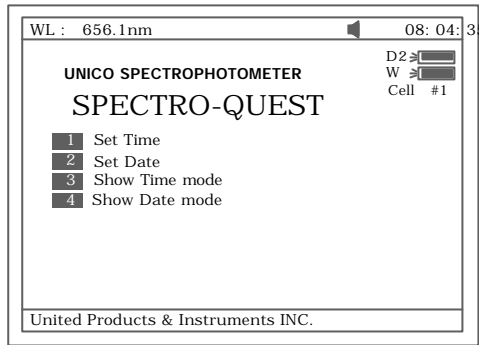

Fig 85

1. Press **【1】** in Fig 85 to modify time by pressing the numeric keypad (Fig 86).

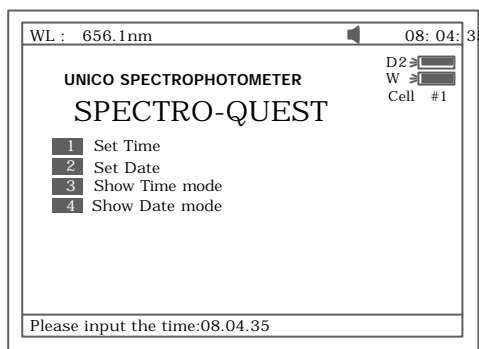

Fig 86

2. Press **【2】** in Fig 85 to modify date by pressing the numeric keypad.
3. Press **【3】** in Fig 85 to set the date display on the top right corner of the screen.
4. Press **【4】** in Fig 85 to set the time display on the top right corner of the screen (Fig 87).

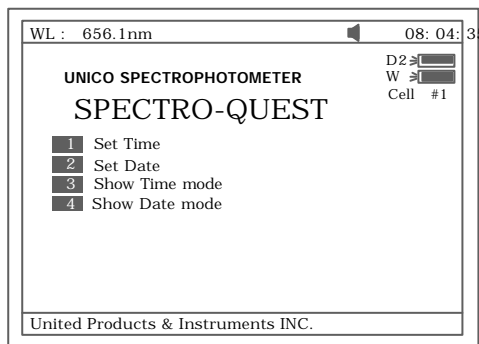

Fig 87

- ☺ Dark Current
Press **【5】** In Fig73 to get dark current (Fig 88).

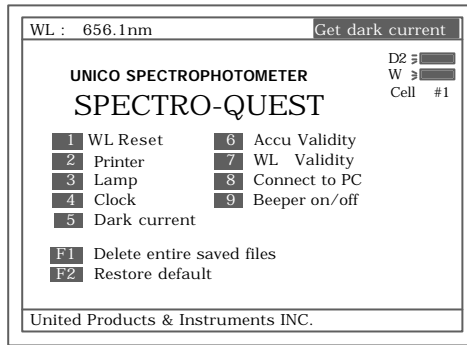

Fig 88

☺ Accu Validity

Press **【4】** In Fig73 to do accu validity (Fig 89). **【ESC/STOP】** to exit.

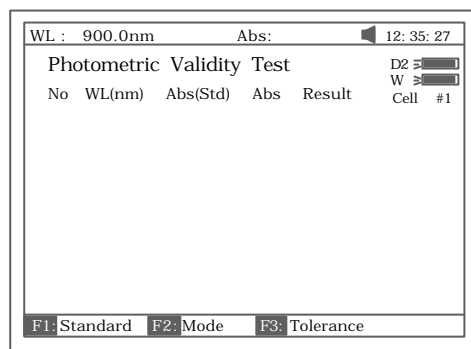

Fig 89

1. Press **【SET】** to set the wavelength. Press **【ENTER】** to edit and input wavelength by pressing the numeric keypad (Fig 90). **【ESC/STOP】** to finish inputting and exit.

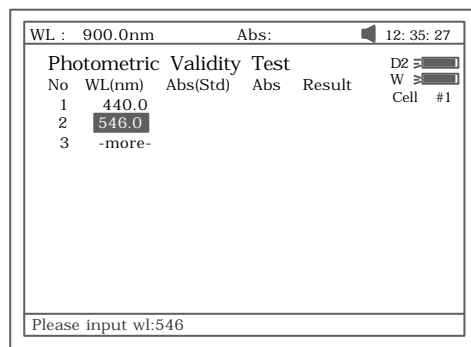

Fig 90

2. Press **【F1】** to set the standard value, Press **【ENTER】** to edit and input by pressing the numeric keypad (Fig 91). **【ESC/STOP】** to finish inputting and exit.

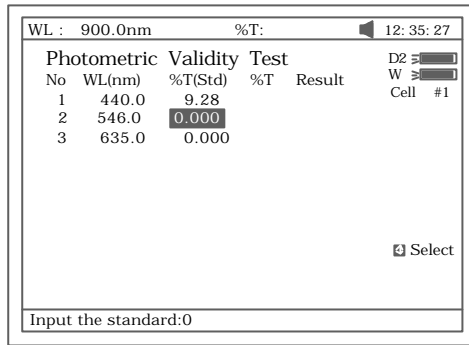

Fig 91

3. Press **【F2】** to select test mode (Abs or %T, Fig 92).

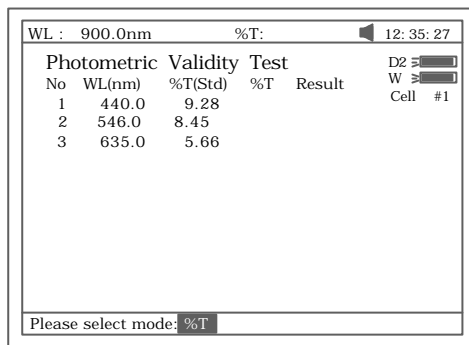

Fig 92

4. Press **【F3】** to set tolerance (Fig 93). Input the value by pressing the numeric keypad.

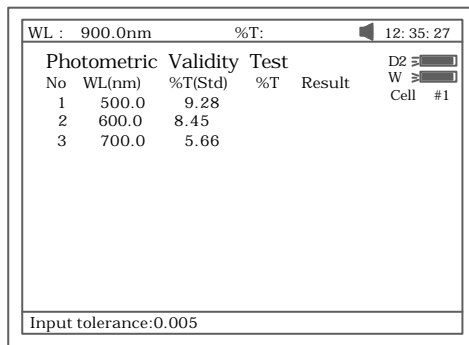

Fig 93

5. Press **【0Abs/100%T】** for Blanking.
6. Put the sample (calibrated neutral density filter) into the light path. Press **【START】** to check. The results will be displayed on the screen (Fig 94). If the discrepancy between the results and the calibrated standards is not more than the tolerance, "pass" will be displayed after the test result. Otherwise, "fail" will be displayed.
7. The result can be saved, loaded and printed by pressing **【SAVE】**, **【LOAD】** and **【PRINT】**.

WL : 900.0nm		%T:		12: 35: 27	
Photometric Validity Test					
No	WL(nm)	%T(Std)	%T	Result	
1	500.0	9.28	9.28	pass	
2	600.0	8.45	8.45	pass	
3	700.0	5.66			

F1: Standard F2: Mode F3: Tolerance

Fig 94

☺ WL Validity

Press **【7】** in Fig 73 to WL validity (Fig 95). **【ESC/STOP】** to exit.

WL : 900.0nm		Abs:		12: 35: 27	
Wavelength Validity Test					
No	WL(nm)	Peak(nm)	T%	Result	

F1: Set peaks F2: Mode F3: Tolerance

Fig 95

1. Press **【F1】** to set the standard peak. Press **【ENTER】** to edit and input wavelength by pressing the numeric keypad (Fig96). **【ESC/STOP】** to finish inputting and exit.

WL : 900.0nm		%T:		12: 35: 27	
Wavelength Validity Test					
No	WL(nm)	Peak(nm)	%T	Result	
1	241.4				
2	361.0				
3	417.0				
4	537.6				
5	641.4				
6	807.4				

Input the standard:0

Fig 96

2. Press **【F2】** to select test mode (Abs or %T, Fig 97).

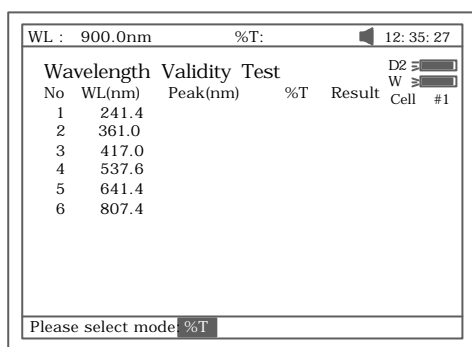

Fig 97

- Press **[F3]** to set tolerance (Fig 98). Input the value by pressing the numeric keypad.

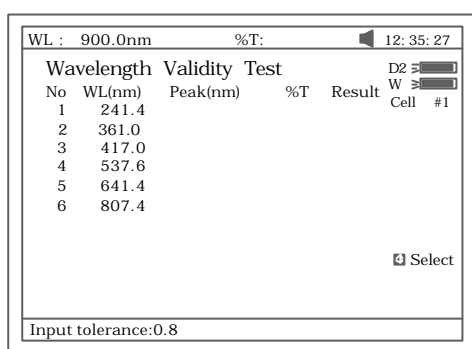

Fig 98

- Press **[0Abs/100%T]** for blanking.
- Put the sample (calibrated holmium liquid) into the light path. Press **[START]** to check. The results will be displayed on the screen (Fig 99). If the discrepancy between the results and the calibrated values is not more than the tolerance, "pass" will be displayed after the test results. Otherwise, "fail" will be displayed.

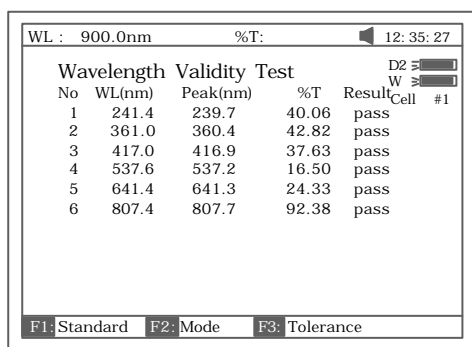

Fig 99

- The result can be saved, loaded and printed by pressing **[SAVE]**, **[LOAD]** and **[PRINT]**

☺ Connect to PC

Press **[8]** in Fig 73 to connect to PC (Fig 100), if the instrument is on-line with

the PC. The screen displays as Fig 100A. Press **【ESC/STOP】** to exit.

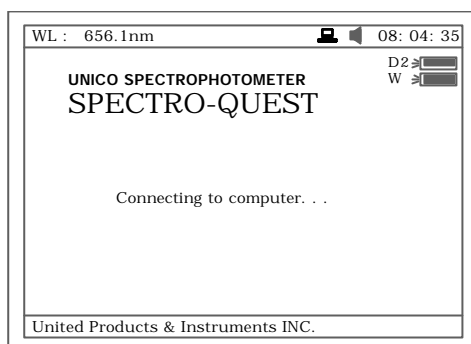

Fig 100

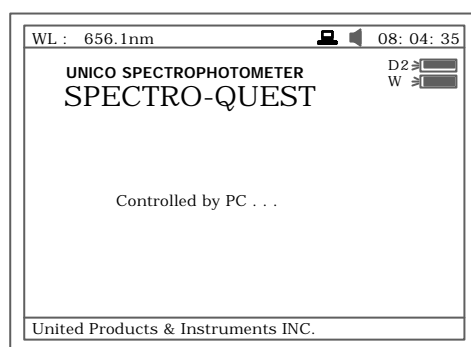

Fig 100A

☺ Beeper on/off

Press **【9】** in Fig 73 to turn on/off the beeper

☺ Delete entire saved files

Press **【F1】** in Fig 73 to delete entire saved files. After the delete the files, double confirm need to do.

☺ Restore default

Press **【F2】** in Fig 73 to restore the default parameters.

Defined test (auto-cell changer required)

Press **【8】** in main menu for “defined test” (Fig 101). **【ESC/STOP】** to exit.

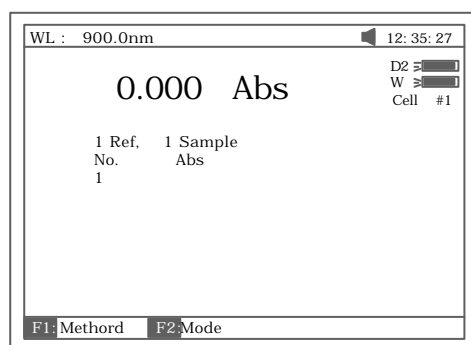

Fig 101

1. Press **【F1】** to setup method (Fig 102). There are 8 items (1 ref. 1 sample, 1 ref. 2 samples, 1 ref. 3 samples, 1 ref. 4 samples, 1 ref. 5 samples, 1 ref. 6 samples, 1 ref. 7 samples, N refs. N samples) for selecting. We take “1 ref. 4 samples” for example, Fig 102

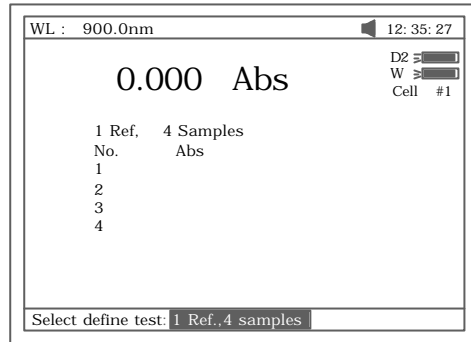

Fig 102

2. Press **【F2】** to select test mode (Abs or %T, Fig 103).

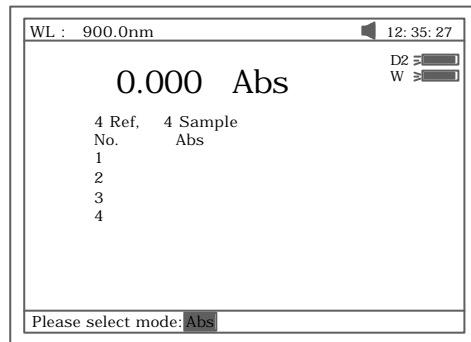

Fig 103

3. Put the reference into cell NO.1 and 4 samples into cell NO.2-NO.5. Set wavelength.
4. Press **【START】**. Automatically the reference is taken in cell NO.1, the 4 samples are taken in cell NO.2-NO.5. The results are displayed as Fig 104.

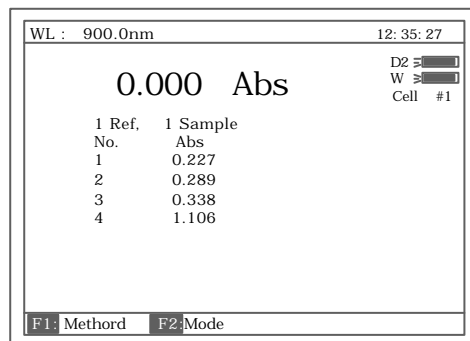

Fig 104

5. Select “N refs. N samples”, Take “8 refs. 8 samples” for example.
6. After setup wavelength and mode (%T or Abs), put 8 references into CELL NO.1-NO.8.

7. Press **START**, the screen display as Fig105, the "Place 1st group..." appear on the right of top line, Press **0Abs/100%T**, the 8 references are taken automatically and the screen change to Fig 106.

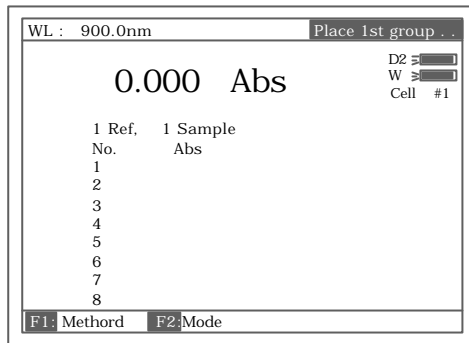

Fig 105

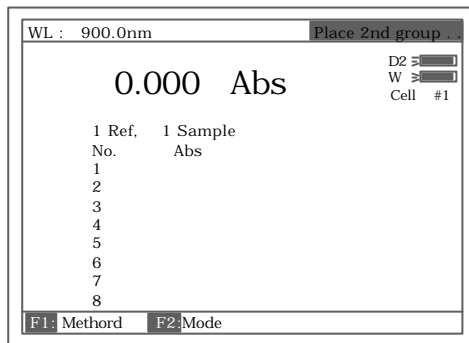

Fig 106

8. Remove 8 references and put 8 samples into CELL NO.1-NO.8, Press the **START**, the results are taken automatically. Fig 107.

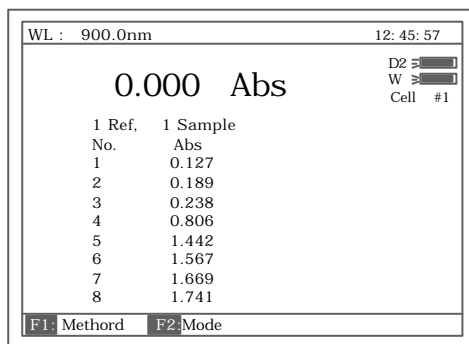

Fig 107

Appendix A

DNA/Protein Test Algorithm

Test Name	Method	Wavelength(s)	Calculations	Parameters	Displayed Units
DNA MEASUREMENT					
DNA/Protein Concentration and DNA purity	Absorbance difference (260,280)	$A_1=A_{260nm}$ $A_2=A_{280nm}$ $A_{ref}=A_{320nm}$ (optional)	DNA concentration: $(A_1-A_{ref})f_1-(A_2-A_{ref})f_2$ Protein concentration $(A_2-A_{ref})f_3-(A_1-A_{ref})f_4$	$f_1=62.9$ $f_2=36.0$ $f_3=1552$ $f_4=757.3$	DNA: μ g/ml Protein: μ g/ml
	Absorbance difference (260,230)	$A_1=A_{260nm}$ $A_2=A_{230nm}$ $A_{ref}=A_{320nm}$ (optional)	DNA concentration: $(A_1-A_{ref})f_1-(A_2-A_{ref})f_2$ Protein concentration $(A_2-A_{ref})f_3-(A_1-A_{ref})f_4$	$f_1=49.1$ $f_2=3.48$ $f_3=183$ $f_4=75.8$	
	Absorbance ratio	$A_1=A_{260nm}$ $A_2=A_{280nm}$ or A_{230nm} $A_{ref}=A_{320nm}$ (optional)	Ratio= $\frac{A_1-A_{ref}}{A_2-A_{ref}}$	None	No units(ratio)

Appendix B

Lamp Replacement



A. TO REPLACE DEUTERIUM LAMP

1. Turn off and unplug the instrument (VERY IMPORTANT: **HIGH VOLTAGE**).
2. Remove the cuvette holder rod by unscrewing the rod counterclockwise.
3. Remove the all screws around the sides of the spectrophotometer. See Fig A1



Fig A1

4. Very carefully remove the cover of the instrument and place in right side of the instrument. Fig A2



Fig A2

HINT: If it is necessary to remove the cover from the right side of the instrument, carefully remove 3 connectors (CZ6, CZ4 and J3) on PCB marked SST8.417.100 . Be sure to reconnect after replacing the lamp!
Fig A3

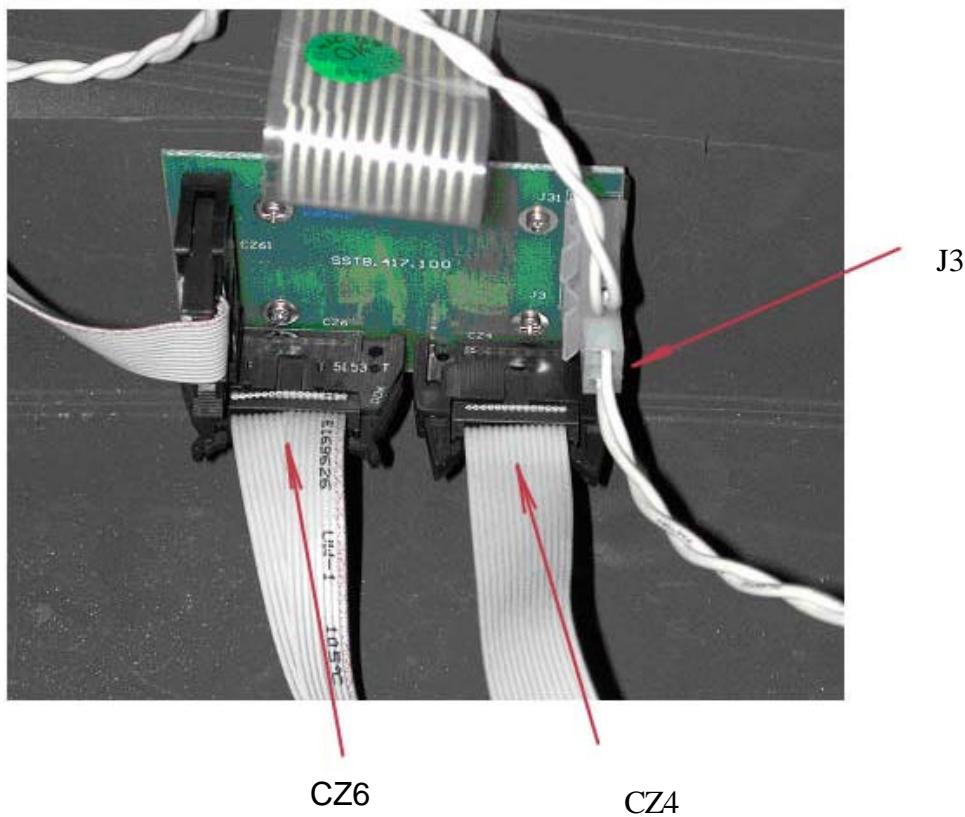

5. Remove the grey metal protection cover. Using screwdrivers remove the two top screws and the two bottom screws, and then

place the protective cover to the side. See Fig A4



Fig A4

6. Disconnecting the connector J7 on the PCB marked SST8.411.128. Unscrew the screw that holds the lamp bracket to the instrument base. Pull the entire lamp and lamp holder assembly out. See Fig A5

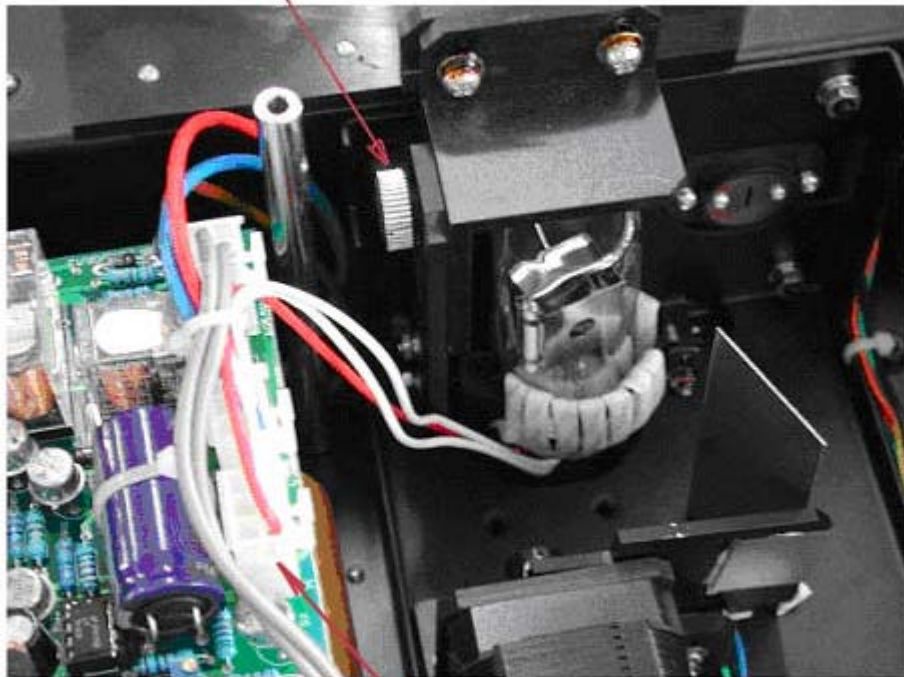

J7
Fig A5

7. Replace the pre-aligned lamp with a lamp (Fig A6) provided by UNICO or an authorized UNICO Service Provider. This comes pre-assembled with lamp socket.

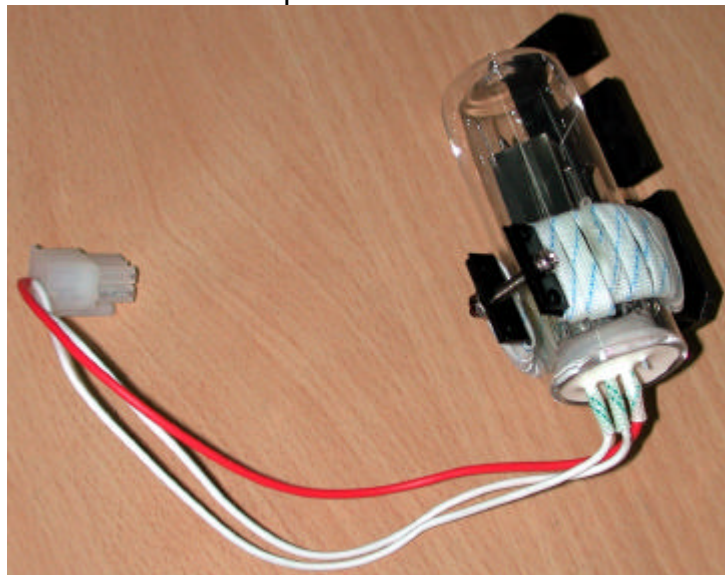

Fig A6

CAUTION: THE LAMP MAY BE HOT! TAKE PRECAUTIONS TO PREVENT POSSIBLE BURNS.

8. Reconnect the connector J7 to the PCB marked SST8.411.128.

9. Re-fit the grey metal protection cover, Fig. A4. Temporarily re-fit the main cover and fix with two screws, one each side. Switch on and remove the grommet from the middle of the rear panel. You can now look through the hole and view the image of the lamp on the slit. Check the lamp alignment Fig. A7. If the image is not covering the slit, the lamp alignment needs adjustment. This requires running the UV-2802 without the covers, with high voltages accessible, and so should only be performed by a suitably qualified engineer. If adjustment is required, remove the cover and grey protection cover, put on UV protection glasses and turn on the instrument. Adjust to make the image central on the slit, Fig. A7. Install the grey metal protection cover and cover of instrument.

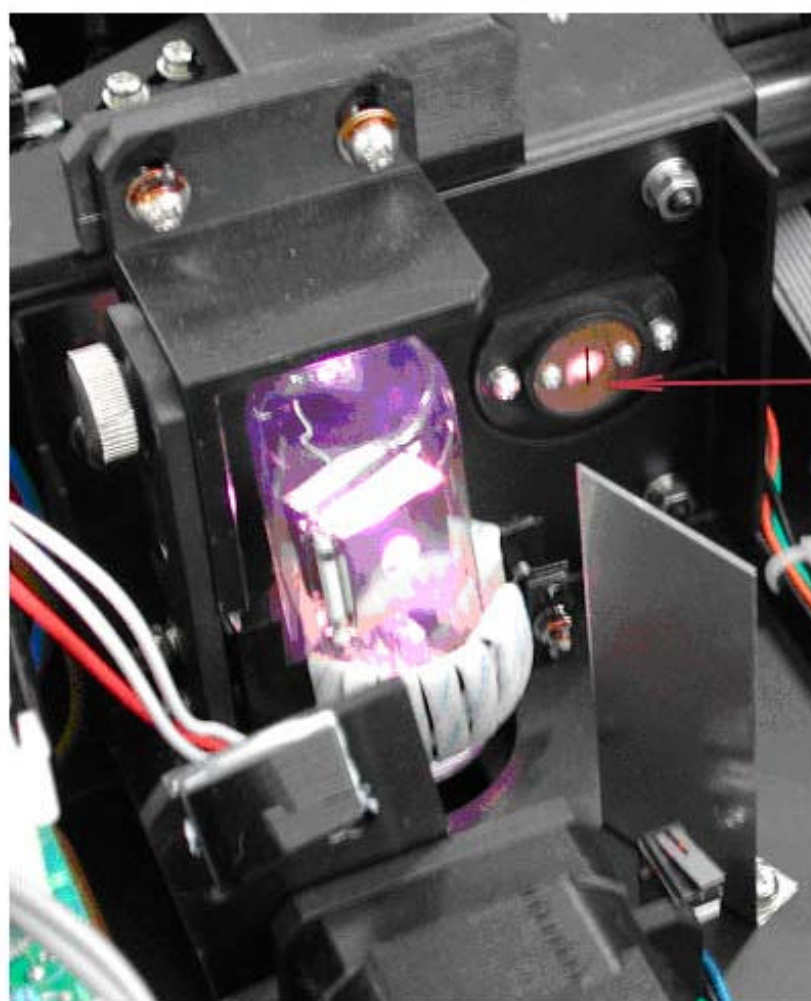

Fig A7

CAUTION: Wear UV protection glasses when replacing deuterium lamp.

10. Re-fit all the screws around the sides of the spectrophotometer, Fig. A1.
11. Re-set the lamp usage time. Select Utility, lamp, and re-set D2 usage time.

B. TO REPLACE TUNGSTEN-HALOGEN LAMP

1. The step 1- step 5 are the same as the **REPLACING DEUTERIUM**.
2. Remove the lamp from the ceramic base.
3. Insert the new lamp (Fig A8), pushing it in as far as it will go.
4. Re-fit the grey metal protection cover, Fig. A4. Temporarily re-fit the main cover and fix with two screws, one each side.
Switch on and remove the grommet from the middle of the rear panel. You can now look through the hole and view the image of the lamp on the slit. Check the lamp alignment Fig. A9. If the image is not covering the slit, the lamp alignment needs adjustment. This requires running the UV-2802 without the covers, with high voltages accessible, and so should only be performed by a suitably qualified engineer.
If adjustment is required, remove the cover and grey protection cover and turn on the instrument. Adjust to make the image central on the slit, Fig. A9.
Install the grey metal protection cover and instrument cover.



Fig A8

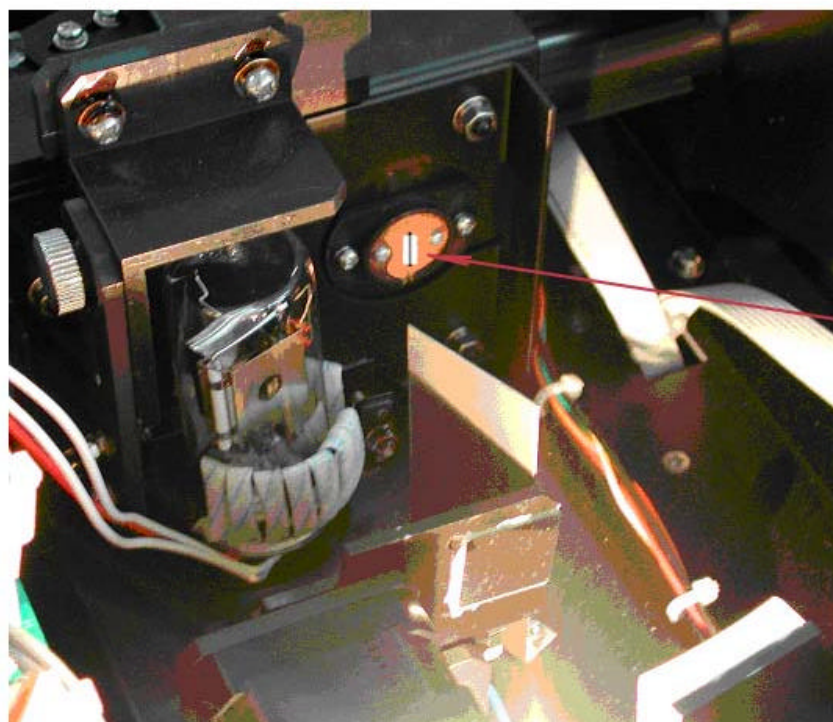

Focus on
the slit

Fig A9

CAUTION: DO NOT HANDLE THE LAMP WITH BARE FINGERS. USE TISSUE OR CLOTH WHEN HANDLING LAMP. The oil from your fingers can cause the lamp to burn out prematurely.

5. Re-fit all the screws around the sides of the spectrophotometer, Fig. A1
6. Install the gray metal protection cover and cover of instrument.
7. Re-set the tungsten lamp usage time. Select Utility, lamp and re-set W lamp usage time.

Appendix C

A number of correction techniques can be used to eliminate or reduce interference errors. In general, if the source of the error is known and is consistent from sample to sample, the error can be eliminated. On the other hand, if the source is unknown and varies from sample to sample, the error can be reduced but not eliminated. Correction techniques can always require data from at least two wavelengths. The more sophisticated correction techniques require multiwavelength or spectral data.

A.1 Isoabsorbance

When a known interfering component with a known spectrum is present, the error introduced by this component at the analytical wavelength for the target analyte can be eliminated by selecting a reference wavelength at which the interfering compound exhibits the same absorbance as it does at the analytical wavelength. The absorbance at this reference wavelength is subtracted from the absorbance at the analytical wavelength, as shown in Figure A1. The residual absorbance is the true absorbance of the analyte.

This technique is less reliable when the spectra of the analyte and of the interferent are highly similar. Moreover, it can correct for only one interference

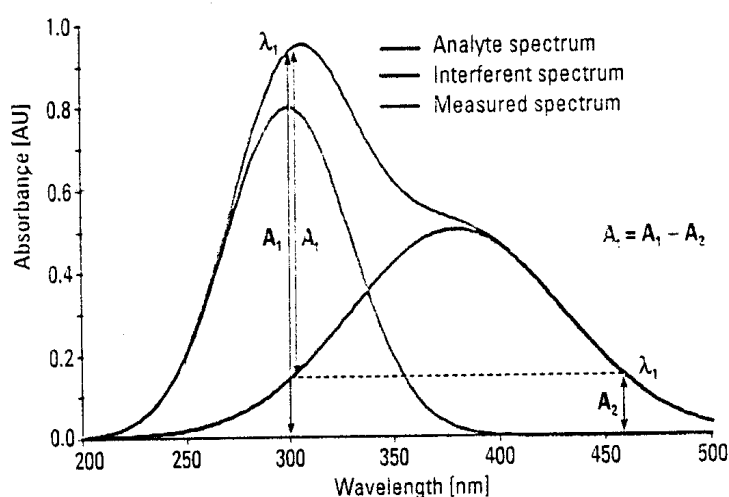

Fig A1 Isoabsorbance correction

A.2 Three-point correction

The three-point, or Morton-Stubbs correction uses two reference wavelengths, usually those on either side of the analytical wavelength.

The background interfering absorbance at the analytical wavelength is then estimated using linear interpolation (see Figure A2). This method represents an improvement over the single-wavelength reference technique because it corrects for any background absorbance that exhibits a linear relationship to the wavelength. In many cases, if the wavelength range is narrow, it will be a reasonable correction for non-linear background absorbances such as that resulting from scattering of from a complex matrix.

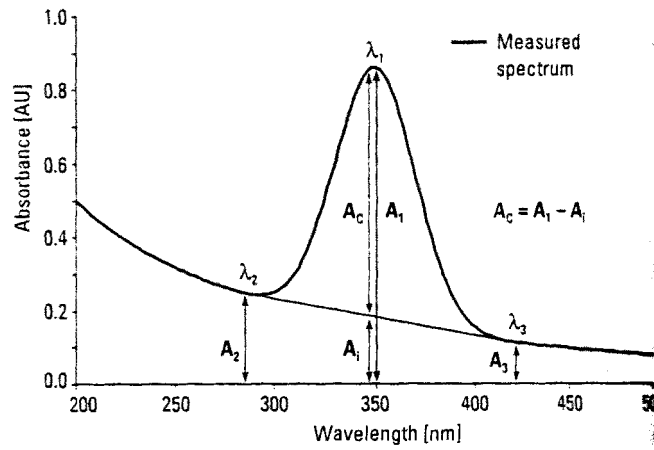

Fig A2