

LD SERIES

Laser Type Edge Detection Sensor



Easy measurement of
outer diameter



High accuracy measurement

A red semiconductor laser is used as the emitting device and CCD is used as the receiving device. An ideally parallel optical beam is emitted enabling high accuracy measurement.

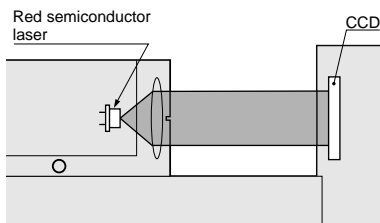

FDA standard conforming

FDA standard (Class II) conforming model **LD-601** is available.

Safety countermeasures not required

Safety countermeasures, such as protective gear, etc., are not required since **LD-600** uses a Class 1 laser as per JIS standards, and **LD-601** uses a Class II laser as per FDA standards.

Optical alignment not required

Cumbersome optical beam alignment is not required since the emitter and the receiver are mounted on one body.

Stable sensing

Shading correction function which compensates for receiver sensitivity variation and generates a uniform sensitivity distribution has been incorporated. Stable sensing over extended time periods is possible.

Various applications

The sensor can be used for various applications with its binary data output with four different sensing modes.

- ① **Width measurement / Dark mode**
The first dark region from the lower side of the measurement region is measured.
- ② **Width measurement / Light mode**
The first light region from the lower side of the measurement region is measured.
- ③ **Edge measurement / Dark mode**
The first dark edge from the lower side of the measurement region is sensed and the width from the dark edge to the upper side of the measurement region is measured.
- ④ **Edge measurement / Light mode**
The first light edge from the lower side of the measurement region is sensed and the width from the light edge to the upper side of the measurement region is measured.

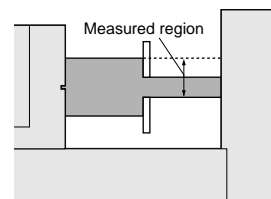
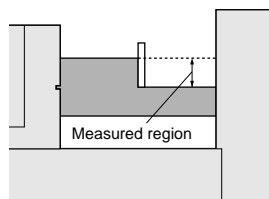
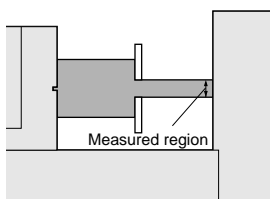
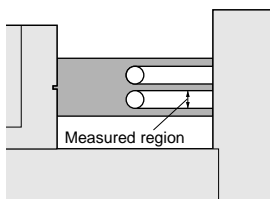

APPLICATIONS

Sensing inclination or notch of wafer

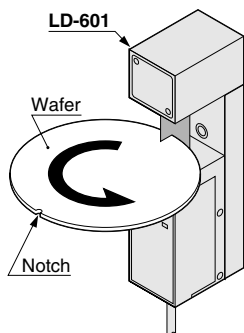

Judging height of small objects

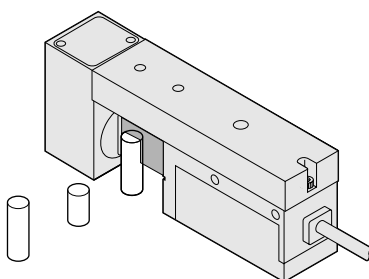

Measuring pipe's outer diameter

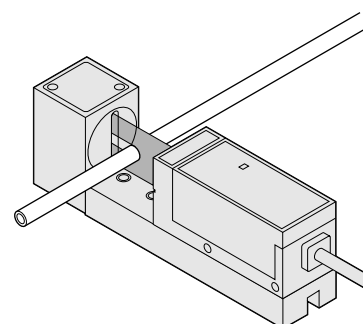

ORDER GUIDE

Sensor heads

| Appearance | Distance between emitter and receiver | Sensing width | Min. sensing object | Model No. | Conforming standards |
|------------|---------------------------------------|----------------|----------------------------------|---------------|---------------------------|
| | 40 mm 1.575 in (fixed) | 15 mm 0.591 in | $\phi 0.5$ mm $\phi 0.020$ in | LD-600 | IEC / JIS standards |
| | | | | LD-601 | FDA / IEC / JIS standards |

Controller

| Appearance | Model No. | Output |
|------------|---------------|-------------------------------|
| | LD-C60 | NPN open-collector transistor |

Make sure to use the sensor head and the controller as a set.

OPTION

| Designation | Model No. | Description |
|------------------|-------------------|--|
| DIN rail adapter | MS-DIN-IDC | Adapter for mounting the controller on a 35 mm 1.378 in width DIN rail |

DIN rail adapter
• MS-DIN-IDC

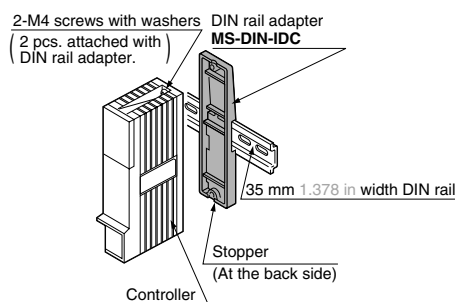

SPECIFICATIONS

Sensor heads

| Conforming standards | | IEC / JIS standards | FDA / IEC / JIS standards |
|---------------------------------------|-----------|---|---|
| Item | Model No. | LD-600 | LD-601 |
| Applicable controller | | LD-C60 | |
| Distance between emitter and receiver | | 40 mm 1.575 in (fixed) | |
| Sensing width | | 15 mm 0.591 in (beam width: 20 mm 0.787 in) | |
| Min. sensing object | | φ0.5 mm φ0.020 in | |
| Resolution | | 11 μm 0.433 mil | |
| Scan time | | 0.6 ms approx. | |
| Emitting element | | Red semiconductor laser Class 1 (IEC / JIS standards) (Max. output: 0.45 mW, Peak emission wavelength: 670 nm 0.026 mil) | Red semiconductor laser Class II (FDA standards) (Max. output: 0.45 mW, Peak emission wavelength: 670 nm 0.026 mil (IEC / JIS standards: class 1)) |
| Power indicator | | Red LED (lights up when power is ON) | _____ |
| Laser emission indicator | | _____ | Green LED (Lights up during laser emission) |
| Ambient temperature | | 0 to +40 °C +32 to +104 °F (No dew condensation), Storage: -10 to +60 °C +14 to +140 °F | |
| Ambient humidity | | 35 to 85 % RH, Storage: 35 to 85 % RH | |
| Enclosure earthing | | Capacitor earth | |
| Material | | Emitter enclosure: Die-cast zinc Receiver enclosure: Aluminum, Base: Aluminum Top cover: PPO, Front protection cover: Glass | |
| Cable | | 6-core (0.22 mm ² × 4, 0.18 mm ² × 2) cabtyre cable, 1 m 3.281 ft long (with connector on one side) | |
| Weight | | 420 g approx. | |
| Accessories | | M4 (length 12 mm 0.472 in) hexagon-socket-head bolt: 2 pcs. | M4 (length 12 mm 0.472 in) hexagon-socket-head bolt: 2 pcs. Laser attenuator: 1 pc. |

Controller

| Model No. | | LD-C60 |
|--|-------|---|
| Item | | LD-600, LD-601 |
| Applicable sensor head | | LD-600, LD-601 |
| Sensing modes | | Width measurement, edge measurement |
| Measuring accuracy | | Width measurement: ± 44 μm ± 1.732 mil Edge measurement: ± 22 μm ± 0.866 mil |
| Supply voltage | | 24 V DC ± 10 % Ripple P-P 10 % or less |
| Current consumption | | 250 mA or less (including sensor head) |
| Input (REQ, SHD) | | Signal conditions: Low...0 to 1 V High...5 to 30 V, or open Applied voltage: 30 V DC or less |
| Output (ACK, D ₀ to D ₁₀) | | NPN open-collector transistor <ul style="list-style-type: none"> • Maximum sink current: 20 mA • Applied voltage: 30 V DC or less (between output and 0 V) • Residual voltage: 1 V or less (at 20 mA sink current) |
| Output operation | | ACK: ON during data output, D ₀ to D ₁₀ : pixel binary output |
| Response time | | 1.2 ms or less |
| Indicators | Power | Red LED (lights up when the power is ON) |
| | REQ | Red LED (lights up when the REQ input is Low) |
| | ACK | Red LED (lights up when the ACK output is ON) |
| Measurement display | | 4 digit LED (letter height 8 mm 0.315 in) |
| Display resolution | | 10 μm 0.394 mil |
| Ambient temperature | | 0 to +40 °C +32 to +104 °F (No dew condensation) Storage: -10 to +60 °C +14 to +140 °F |
| Ambient humidity | | 35 to 85 % RH, Storage: 35 to 85 % RH |
| Material | | Enclosure: ABS, Front panel: ABS Display panel: Polycarbonate, Terminal cover: Polycarbonate |
| Weight | | 230 g approx. |
| Accessory | | Connector: 1 pc. |

I/O CIRCUIT AND WIRING DIAGRAMS (CONTROLLER)

I/O circuit diagram

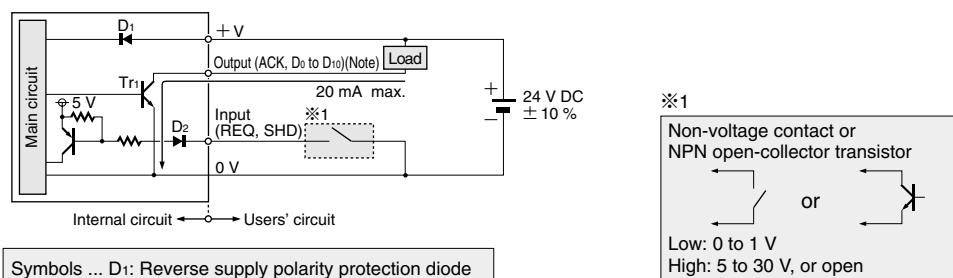

Symbols ... D1: Reverse supply polarity protection diode
D2: Reverse current protection diode
Tr: NPN output transistor

Note: Insulate all unused wires individually to avoid miscontact.

I/O Terminal Arrangement

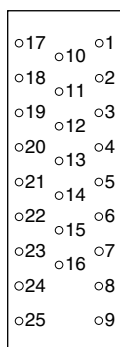

Attached connector
Solder side

| Pin No. | Symbol | I/O | Description | Pin No. | Symbol | I/O | Description |
|---------|----------------|--------|------------------------|---------|-----------------|--------|-------------------------|
| 1 | REQ | Input | Data output request | 14 | D ₄ | Output | Data (2 ⁴) |
| 2 | ACK | Output | Data being output | 15 | D ₅ | Output | Data (2 ⁵) |
| 3 | SHD | Input | Shading correction | 16 | D ₆ | Output | Data (2 ⁶) |
| 4 | — | — | Not connected | 17 | D ₇ | Output | Data (2 ⁷) |
| 5 | — | — | Not connected | 18 | D ₈ | Output | Data (2 ⁸) |
| 6 | — | — | Not connected | 19 | D ₉ | Output | Data (2 ⁹) |
| 7 | — | — | Not connected | 20 | D ₁₀ | Output | Data (2 ¹⁰) |
| 8 | G | — | 0 V | 21 | — | — | Not connected |
| 9 | G | — | 0 V | 22 | — | — | Not connected |
| 10 | D ₀ | Output | Data (2 ⁰) | 23 | — | — | Not connected |
| 11 | D ₁ | Output | Data (2 ¹) | 24 | G | — | 0 V |
| 12 | D ₂ | Output | Data (2 ²) | 25 | G | — | 0 V |
| 13 | D ₃ | Output | Data (2 ³) | | | | |

PRECAUTIONS FOR PROPER USE



This product is not a safety sensor. Its use is not intended or designed to protect life and prevent body injury or property damage from dangerous parts of machinery. It is a normal object detection sensor.



- Although this product corresponds to a Class 1 laser product, it is dangerous to see the laser beam which has been passed through a viewing optical system such as a lens, etc. Hence, please avoid this.
- This product has been designed to meet the specifications when it is used along with the optional exclusive controller. If a controller other than the exclusive controller is used, not only the specifications may not be met, but it may also be a cause for malfunction or break down. Hence, please ensure to use this product along with the optional exclusive controller.
- Before using this product, please allow a warming up time of 3 min. approx. after the power supply is switched on.
- Never disassemble the sensor head.

Conditions in use for CE conformity

The LD series is a CE conformity product complying with EMC Directive. The harmonized standard with regard to immunity that applies to this product is EN 61000-6-2 (Note) and the following conditions must be met to conform to that standard.

Conditions

- This controller should be connected less than 10 m 32.808 ft from the power supply.
- The signal line to connect with this controller should be less than 30 m 98.425 ft.

Note: The EN 50082-2 that previously applied to the products for conforming to EMC Directive was replaced by EN 61000-6-2 starting April 1st, 2002.

Safe use of laser products

- For the purpose of preventing users from suffering injuries by laser products, JIS C 6802-1997 (Safety radiation standard for laser products) has been established based on IEC standards. Kindly check the standards before use.

Safety standards for laser beam products

- A laser beam can harm human being's eyes, skin, etc., because of its high energy density. IEC and JIS have classified laser products according to the degree of hazard and the stipulated safety requirements. The LD series is classified as Class 1 laser.

| Class | Applicable model No. | Degree of danger |
|----------|-------------------------|---|
| Class 1 | LD-600 LD-601 (Note) | Intrinsically safe design. |
| Class 2 | — | Visible and low power (wavelength 400 to 700 nm 0.016 to 0.028 mil). Eyes react instinctively to laser beam and protect themselves. |
| Class 3A | — | Dangerous if eyes are exposed to laser beam through optical means. Visible beam should be 5 mW or less. Invisible beam should not exceed 5 times the Class 1 power. |
| Class 3B | — | Dangerous if eyes are exposed to laser beam directly. Unfocused, pulsed laser radiation 0.5 W or less can be observed by means of diffuse reflection. |
| Class 4 | — | Too intense. Even diffuse reflection is possibly dangerous. It can burn the skin or cause a fire. |

Note: LD-601 conforms to FDA Class II.

Mounting

- Mount the sensor head using the attached 2 pcs. M4 (length 12 mm 0.472 in) hexagon-socket-head bolts, with a tightening torque of 1.2 N·m or less.

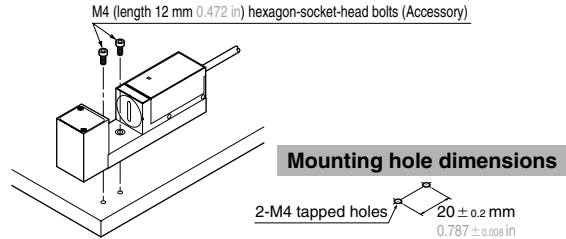

- Mount the controller using 2 pcs. M4 pan head screws, with a tightening torque of 1.2 N·m or less.

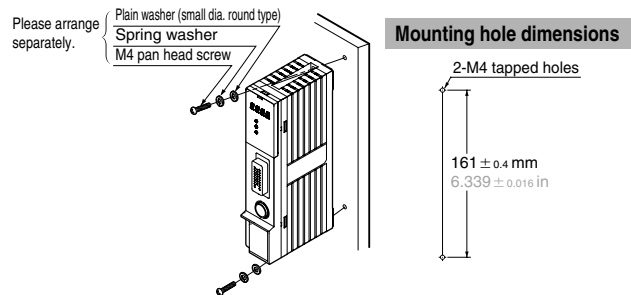

Wiring

- Make sure that the power supply is off while wiring.
- Verify that the supply voltage variation is within the rating.
- Make sure to use an isolation transformer for the power supply. If an auto-transformer (single winding transformer) is used, this product or the power supply may get damaged.
- In this sensor head, capacitor earth is used to enhance the noise characteristics. In case there is a high frequency noise generating equipment, such as, an ultrasonic welding machine, etc., near the sensor head and if the mounting base is electrically conducting (metallic, etc.), then insulate the sensor head from the mounting base.
- In case noise generating equipment (switching regulator, inverter motor, etc.) is used in the vicinity of the sensor head or the controller, connect the frame ground (F.G.) terminal of the equipment to an actual ground.
- In case a surge is generated in the used power supply, connect a surge absorber to the supply and absorb the surge.
- Do not run the wires together with high-voltage lines or power lines or put them in the same raceway. This can cause malfunction due to induction.
- In order to reduce noise, make the wiring as short as possible.

Others

- This product is not a measuring instrument. Hence, the company does not offer any calibration services.
- Do not allow any water, oil, fingerprints, etc., which may refract light, or dust, dirt, etc., which may block light, to stick to the emitting / receiving surfaces of the sensor head. In case they are present, wipe them with a clean, soft cloth or lens paper.
- Avoid dust, dirt, and steam.
- Take care that the sensor head and the controller does not come in direct contact with water, oil, grease, or organic solvents, such as, thinner, etc.
- Take care that the sensor head and the controller are not directly exposed to fluorescent light from a rapid-starter lamp or a high frequency lighting device, as it may affect the sensing performance.

DIMENSIONS (Unit: mm in) The CAD data in the dimensions can be downloaded from the SUNX website: <http://www.sunx.co.jp/>

**LD-600
LD-601** Sensor head

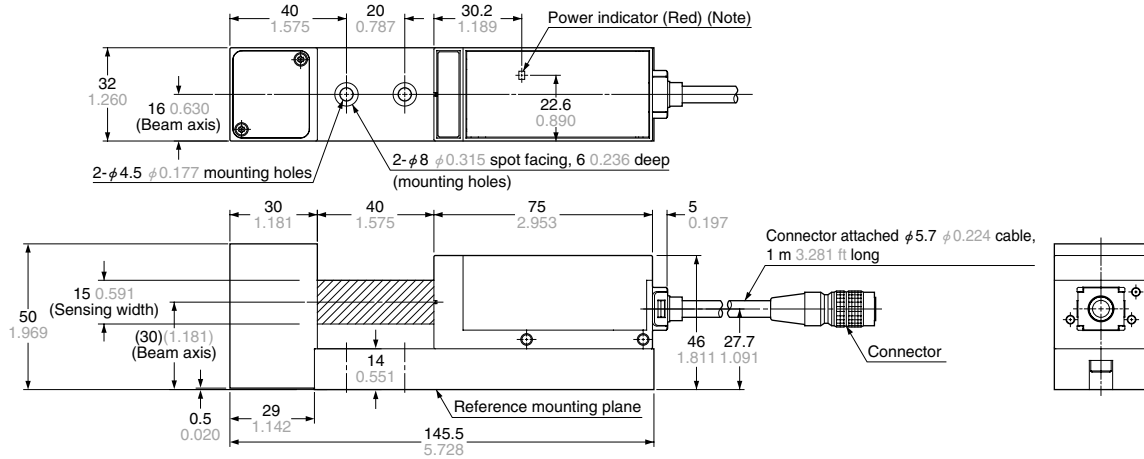

Two M4 (length 12 mm 0.472 in) hexagon-socket-head bolts are attached.
 Note: In LD-601, this is the laser emission indicator (green).

Light / Reflective Type
 HL-C1
 LH-50
 LM10

HL-T1

LD-C60 Controller

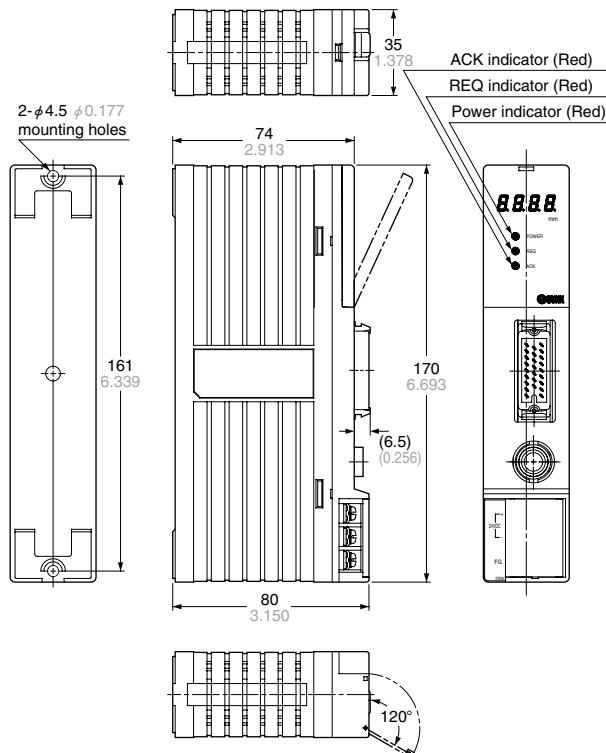

MS-DIN-IDC DIN rail adapter (Optional)

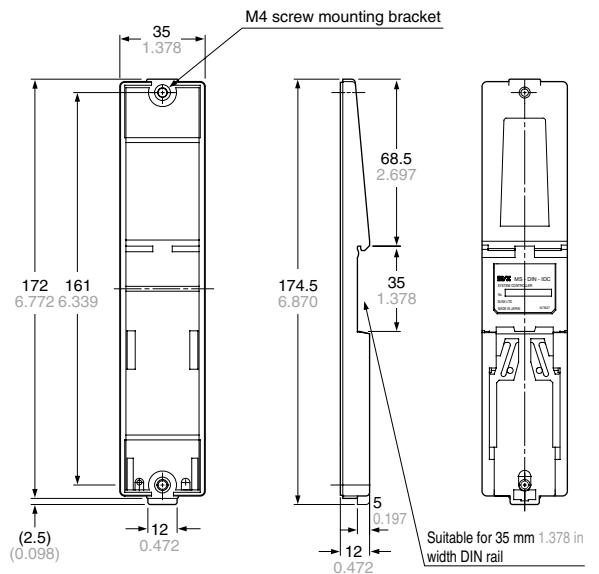

Two M4 (length 12 mm 0.472 in) screws with washers are attached.

Light / Thru-beam Type
 LA-300
 LA

LD

Magnetic Displacement
 GP-A
 GP-X