



AdaptaBeacon® Rotating Lights

Weatherproof

53 Series

FEATURES

- > Weatherproof
- > Light intensifying reflector
- > 75 revolutions per minute
- > Bayonet lamp socket for easy replacement
- > Cast base can be utilized as junction box
- > May be mounted vertically, facing up or down in 3 ways:
 - Direct Surface
 - 4" (102mm) octagon box
 - 1/2" (13mm) NPT conduit

Rotating signal designed to provide maximum brilliance and long term durability with minimum maintenance. The polycarbonate dome allows for easy cleaning.

For direct mounting applications, unit is supplied complete with gasket and rubber expansion plugs. For weatherproof installation unit must be mounted vertically with the dome facing up. May be corner mounted using the Cat. No. CBR, corner mount bracket, or wall mounted using the Cat. No. WBR, wall mount bracket. See AdaptaBeacon Accessories, page 3-118.

Designed to attract attention or indicate equipment malfunctions in noisy areas. Used in security systems to visually show indication of an intrusion. Also used in factory and distribution facilities to alert workers of oncoming fork truck traffic.

D-04



TECHNICAL INFORMATION

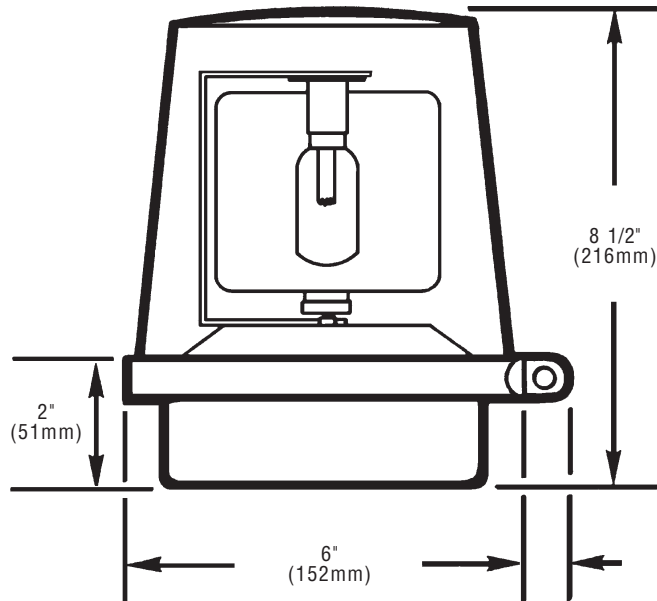

Cat. No.	Lens Color	Replacement Lens Cat. No.	Lamp Ratings	Revolution Rate	Electrical Ratings	Replacement Lamp Cat. No.
53C-E1	Clear	52-LC	25 Watts	75 rpm	12V DC	Industry Trade No. 1076
53R-E1	Red	52-LR	402 lumens*		1.8 Amps	
53A-E1	Amber	52-LA	5049 candlepower			
53B-E1	Blue	52-LB	200 hours**			
53G-E1	Green	52-LG				
53C-G1	Clear	52-LC	25 Watts	75 rpm	24V DC	Industry Trade No. 1638
53R-G1	Red	52-LR	402 lumens*		1.0 Amp	
53A-G1	Amber	52-LA	5049 candlepower			
53B-G1	Blue	52-LB	500 hours**			
53G-G1	Green	52-LG				

*Manufacturer's lumen rating.

**Projected lamp life based on manufacturer's calculated lamp life @ 65 FPM and 50% duty cycle.