

FCR Rack Mount Fiber Panels

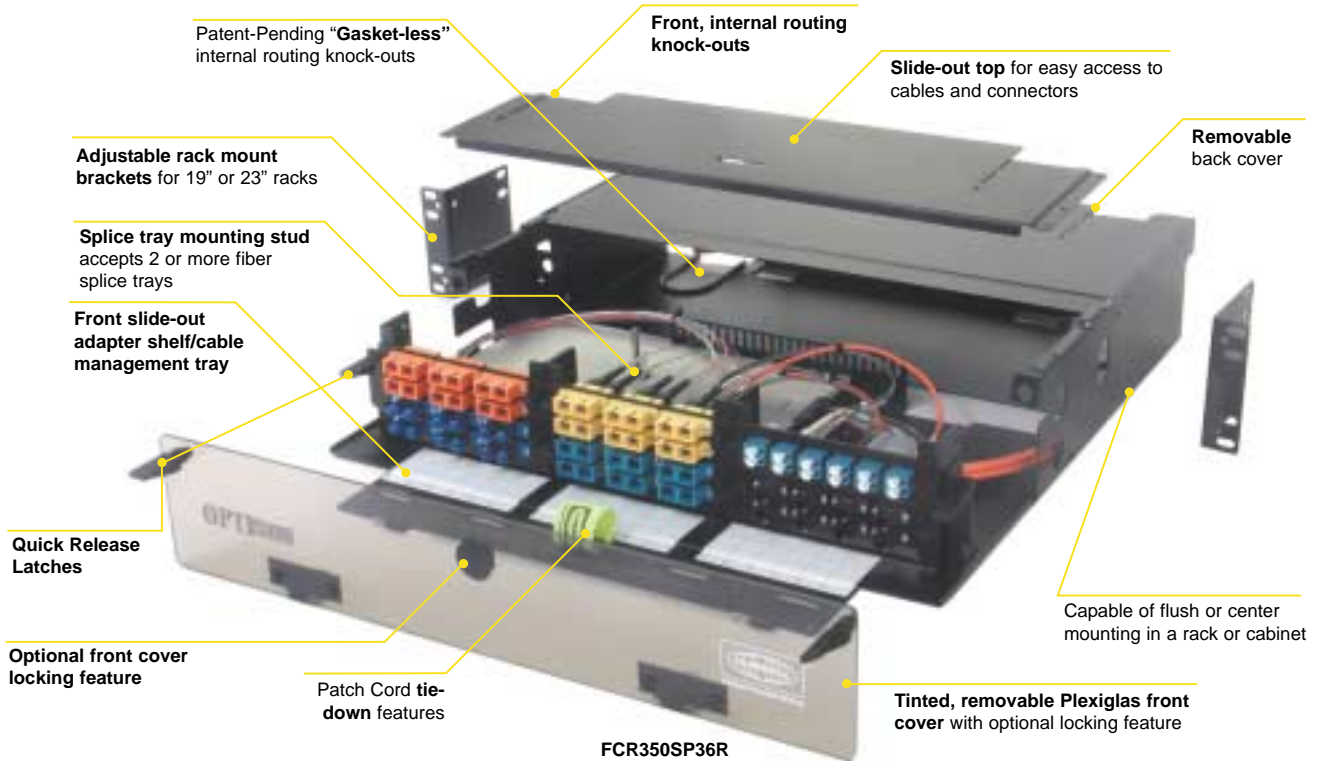

The OPTIchannel FCR Rack Mount Fiber Patch Panels provide superior fiber cable management and patch cord protection while allowing quick and easy access to connectors and splices. Available in 2, 3, or 4 rack unit heights, these panels have been designed with innovative features for both the cable

systems installer and the fiber data manager. All FCR panels utilize Hubbell's FSP Adapter Panels (sold separately) for connector modularity and flexibility. These panels also provide a convenient way to store cable and patch cords.

FEATURES	BENEFITS
■ Front slide-out adapter shelf/cable management tray	➤ Superior cable and connector accessibility
■ Quick release front flip latches	➤ Easy opening and access to patch cords
■ Patent-pending "gasket-less" internal routing knock-outs	➤ Internal routing and protection of pigtails
■ Adjustable rack mounting brackets	➤ Flexibility for flush or extended mounting
■ Optional front cover locking feature	➤ Tamper-resistance and security
■ Removable top, front and rear cover	➤ Easy access during installation
■ Patch cord and cable routing features	➤ Organized and secure cable management
■ Accepts FSP Adapter Panels	➤ Connector modularity/flexibility
■ XPert™ Label compatible	➤ Allows for enhanced label identification

ORDER INFORMATION

FCR Rack Mount Panels

Accepts FSP Adapter Panels	Typical Port Capacities		"H" Height	Rack units	Catalog No.
	Standard ST/SC	High-Density ST/SC			
6	36/36	48/72	3.50" (89)	2	FCR350SP36R
9	54/54	72/108	3.50" (89)	2	FCR350SP54R
12	72/72	96/144	5.25" (133)	3	FCR525SPR
15	90/90	120/180	7.00" (178)	4	FCR700SP

SPECIFICATIONS

- ◆ 16 ga. cold rolled steel construction
- ◆ Durable black powder coat finish
- ◆ Approximate unloaded weight: FCR350: 11 lbs., FCR525: 15 lbs., FCR700: 17 lbs.
- ◆ Dimensions: 17"W (432) x 12"D (305)
- ◆ Accepts a maximum of two 10" splice trays - for additional splice capacity, use the FSS01 or FCR350SE

Dimensions (FCR350SP36R shown)

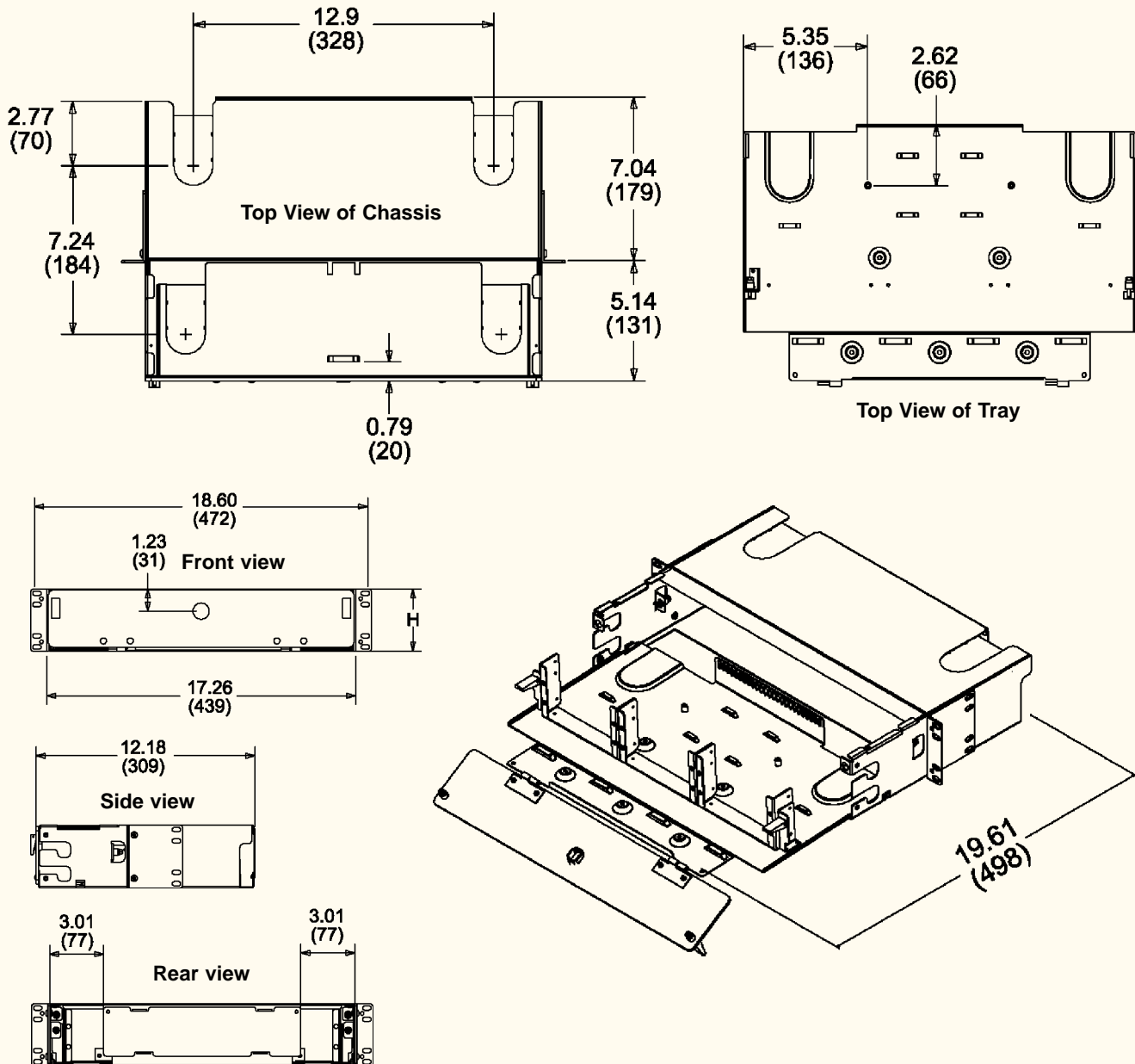

Hubbell Premise Wiring

HUBBELL INCORPORATED (Delaware)
 14 Lord's Hill Road • Stonington, CT 06378-0901 • (860) 535-8326 • 800-626-0005
 Fax: (860) 535-8328 • Internet site: <http://www.hubbell-premise.com>

Worldwide Locations

Hubbell Premise Wiring, Asia Pacific	852-2836-7131	Fax: 852-2836-7132	Hubbell de Mexico, S.A. de C.V.	52-5-575-2022	Fax: 52-5-559-8626
Hubbell Canada Inc.	905-839-1138	Fax: 905-839-9108	Hubbell Premise Wiring, Middle East	971-4-393-4192	Fax: 971-4-393-4194
Hubbell Premise Wiring, China	86-21-6217-3478	Fax: 86-21-6217-3481	Hubbell Premise Wiring, Puerto Rico	787-720-7185	Fax: 787-789-2796
Hubbell Premise Wiring, Europe	44-(0)1234-848550	Fax: 44-(0)1234-856190	Hubbell-Taian Co., Ltd., Taiwan	886-2-(0)2515-0855	Fax: 886-2-(0)2515-0899
Hubbell Int'l. Inc., Korea Branch	82-2-(0)2607-1363	Fax: 82-2-(0)2603-7386	Hubbell Incorporated, Turkey	90-216-414-8147	Fax: 90-216-414-8148
Hubbell Premise Wiring, Latin America	305-251-4236	Fax: 305-251-4087	Hubbell Premise Wiring, Venezuela	58-16-6807453	Fax: 58-281-2820323