

## 2104

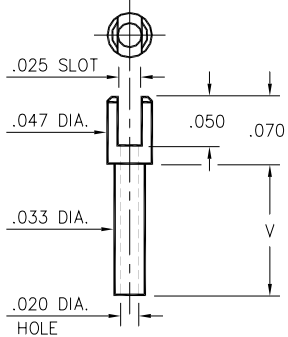

- X -	Board Thickness	Length V
1	.031	.055
2	.062	.086
3	.094	.117
4	.125	.148

**2104-X-01-XX-00-00-07-0**  
Swage mount in .036 hole

## 2112

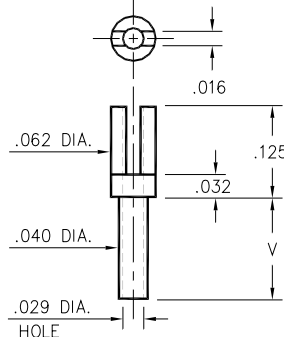

- X -	Board Thickness	Length V
5	.016	.037
1	.031	.053
2	.062	.084
3	.094	.115
4	.125	.147

**2112-X-01-XX-00-00-07-0**  
Swage mount in .043 hole

## 2105

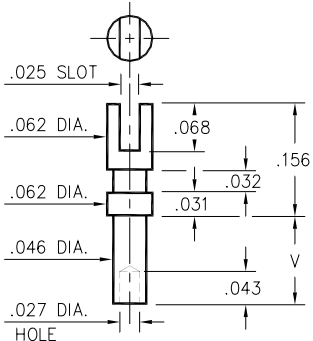

- X -	Board Thickness	Length V
1	.031	.055
2	.062	.086
3	.094	.117
4	.125	.149

**2105-X-01-XX-00-00-07-0**  
Swage mount in .052 hole

## 2103

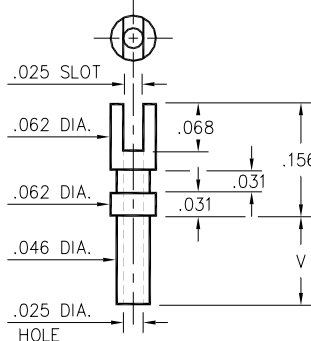

- X -	Board Thickness	Length V
1	.031	.058
2	.062	.089
3	.094	.120
4	.125	.150

**2103-X-01-XX-00-00-07-0**  
Swage mount in .052 hole

## 2106/2107

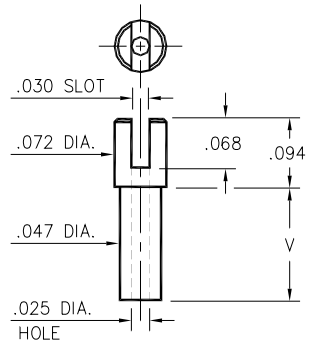

**2106-X-01-XX-00-00-07-0**  
Swage mount in .052 hole

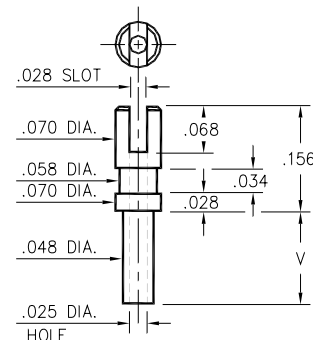

**2107-X-01-XX-00-00-07-0**  
Swage mount in .052 hole

- X -	Board Thickness	Length V
1	.031	.051
2	.062	.082
3	.094	.113
4	.125	.145

### SPECIFICATIONS

**PIN MATERIAL:**  
Brass Alloy 360, 1/2 Hard  
Swage pins are annealed

**DIMENSION IN INCHES**  
**TOLERANCES ON:**  
LENGTHS: ±.005  
DIAMETERS: ±.002  
ANGLES: ± 2°

**ORDER CODE: 21XX - X - 01 - XX - 00 - 00 - 07 - 0**

**BASIC PART #** →

**SPECIFY PIN FINISH:**  
**01** 100μ" TIN/LEAD OVER NICKEL  
**44** 300μ" SILVER OVER COPPER  
**50** 300μ" ELECTRO-SOLDER  
(60/40 SnPb)