

» VX3030 «

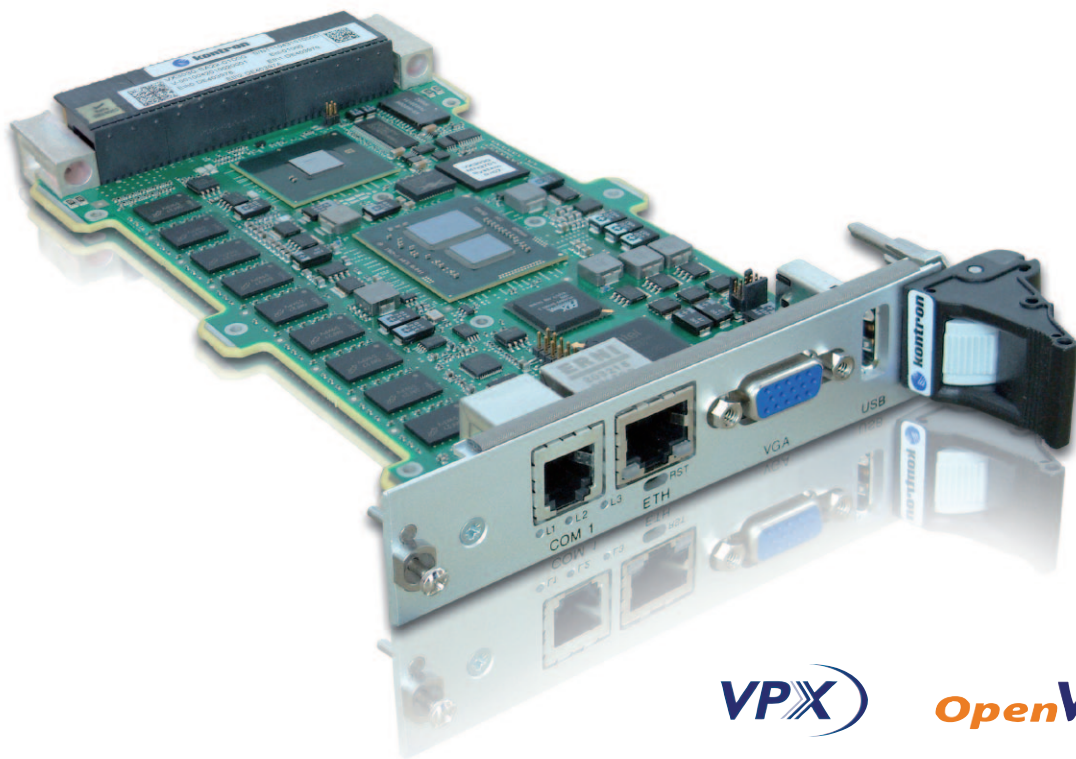

VPX

OpenVPX

3U VPX Intel® Core™ i7 Single Board Computer

- » New Micro Architecture - Quad Execution Thread VPX SBC
- » Intel® Dual-Core™ Core i7 with integrated DDR3 Memory Controller
- » Two Cores with Hyperthreading (4 threads total) from 1.67 GHz to 2 GHz
- » Up to 8 GB on 2 Channels, DDR3 1067 MHz, ECC registered SDRAM
- » Three Gigabit Ethernet Links to VPX Backplane
- » Data plane x4 PCIe. Software configurable x4 or x1 PCIe links
- » UEFI BIOS with PBIT option
- » Air- and Rugged Conduction-Cooled versions under 45W power

Product Overview

VX3030 is a multipurpose 3U VPX rugged single board computer offering the ultimate performance for embedded applications. Coupled with Kontron Long Term Supply policy, this board is poised to become the general purpose small SBC for many generations of embedded applications for the Military and Aerospace market.

Based on Intel®'s high performance computing architecture, VX3030 offers the best features set:

Standards

- » 3U VPX VITA 46, OpenVPX VITA65, VPX REDI VITA 48.
- » Single CPU: compatible with all existing legacy application x86 code.

SWAP-C

- » Four Execution Threads: compact 4-way SMP solution for parallel computing tasks at low power, low size.
- » Turbo Boost: up to 2.5 GHz operation of a single threaded workload in the same power envelope.
- » Integrated Graphics Controller with two DisplayPorts or VGA: for all HMI applications.

Safety Critical

- » Two channels of DDR3 soldered memory with ECC: performance and security.
- » 64 KB of permanent Ferroelectric Random Access Memory (F-RAM) allowing permanent retention of application key operational data.

- » 8 GB of System Flash with Recovery BIOS Image and permanent storage of BIOS parameters.

Rugged Design

- » Rugged Conduction-Cooled version: for the harshest environments.

Connectivity

- » Up to 5 lanes of PCIe to the backplane: I/O extensions at peak bandwidth.
- » 4 SATA ports to the backplane: for secure RAID storage Applications.

Versatility

- » VX3030 is compatible with 0.8" and 1" slot pitch. Pick the best size/ power tradeoff for your application.
- » Extension connectors on top and bottom allow SBC custom extension for cost effective program customizations.

Long Term Supply

VX3030 is the member of Extended Life Cycle product family, which offers a 15-year life cycle organisation on top of Intel® embedded product line silicon life cycle.

Available in Kontron 3U VPX development systems, along with 3U VPX carriers and 3U VPX Ethernet switches, the VX3030 is the ideal candidate for long term programs in search of general purpose or compact high performance parallel computing solutions.

VX3030 Block Diagram and Front Panel

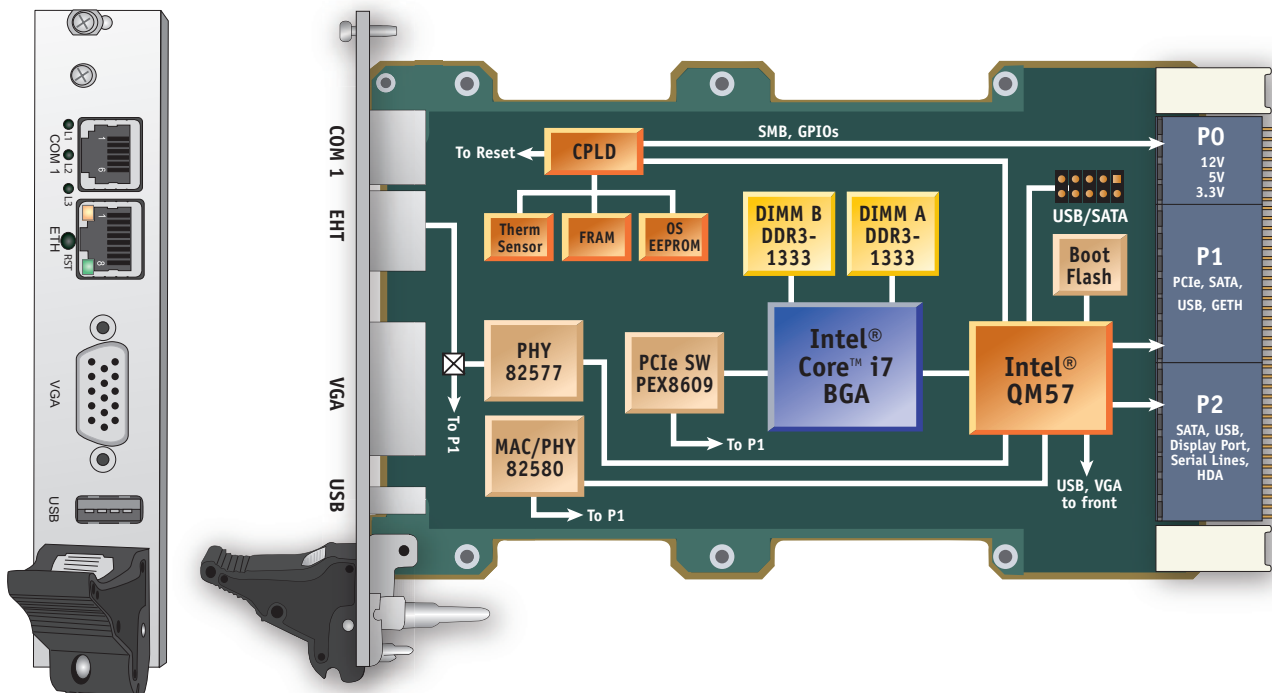

Technical Information

| | |
|--|--|
| Processor | <p>Intel® Core™ i7 processor (32nm manufacturing process):</p> <ul style="list-style-type: none"> » Core i7-620LE: 2.0 GHz, LV, 4 MB L3 cache (shared instruction/data cache between both cores) » Core i7-610E: 2.53 GHz, SV, 4 MB L3 cache (shared instruction/data cache between both cores) <p>Please contact Kontron for further information concerning the suitability of other Intel processors for use with the VX3030</p> |
| Memory | |
| System Memory | Up to 8 GB dual channel DDR3 SDRAM running at 1066 MHz, with ECC, soldered |
| Flash (uEFI BIOS) | 8 MB FLASH, with recovery image and uEFI BIOS settings |
| EEPROM | Serial EEPROM (24LC64) 8 KB for storing product VPD |
| USB/SATA NAND Flash | Flash mezzanine socket for USB or SATA NAND Flash modules (typically 8, 16 or 32 GB) |
| Onboard Controller | |
| Platform Controller Hub | <p>Mobile Intel® QM57 Express Chipset:</p> <ul style="list-style-type: none"> » SATA host controller with six ports with RAID 0/1/5/10 support » USB 2.0 host interface with up to 14 ports (6x ports are used on the VX3030) » 2 x PCI Express x4 or 8x PCI Express x1 2.0 ports |
| Graphics | <p>High performance 3D graphics controller integrated in the processor:</p> <ul style="list-style-type: none"> » Support for two independent displays » Supports digital display resolutions up to 2560 x 1600 pixels @ 60Hz » Supports analog display resolutions up to 2048 x 1536 pixels @ 75Hz » Dynamic Video Memory Technology (DVMT) |
| Gigabit Ethernet | 3 x GbE, 2 1000BASE-BX with Intel i82580 Ethernet controller (rear), One 1000BASE-T with i82577 (front or rear, BIOS option) |
| Watchdog | PLD-based, timeout up to 510s, IRQ, Reset |
| RTC | Integrated in QM57 with 256 Byte CMOS RAM plus separate ultra low power time of day device |
| Front Interfaces 4HP (0,8") or 5HP (1") | |
| VGA | 1 x VGA-CRT 15-pin D-Sub connector |
| USB | 1 x USB 2.0 ports, 4-pin standard USB connectors |
| Ethernet | 1 x RJ45 with integrated LEDs (ACT, SPEED) |
| Serial | 1 x RJ11 one half modem (with CTS/RTS) |
| LED's | 3 bicolor Leds for system info (fault, proc hot, WD), and user application feedback |
| Onboard Interfaces | |
| Debug Interface | XDP port for processor emulation probe connection |
| USB/SATA | 1 x onboard FLASH mezzanine socket for USB or SATA modules |
| Top Layer extension | The high-speed I/O connector holds PCIe x4 channel for I/O extensions (XMC, HDD etc), 3.3V Power |
| Bottom Layer extension | <p>This connector holds the following interfaces</p> <ul style="list-style-type: none"> » PCIe x1 for any I/O extension mezzanine » Four GETH 1000BASE-T signals » 3.3V Power |
| VPX Interface | |
| Slot Profiles | <p>SLT3-PAY-2F2U-14.2.3 SLT3-PAY-1F1F2U-14.2.4 SLT3-PAY-1F1U-14.2.10</p> |
| Rear I/O via P1/P2 | <p>The VX3030 supports:</p> <ul style="list-style-type: none"> » One x4 PCIe non transparent port » Four SATA II ports » Three Gigabit Ethernet ports » Four USB 2.0 ports » Two EDP ports » One HDA port » One PCIe x1 link. » Two simplified EIA232/EIA485 serial (one with CTS/RTS) |
| Supervisory Functions | <ul style="list-style-type: none"> » Non Maskable RESET, » NVMRO, SMB 0 and SMB 1 interfaces for Status, Start , Reset. Compatible with Kontron CMB, temperature and voltage sensors on the board. » PCIe optional reference clock |

Environmental Specification

| | SA - Standard Commercial (1" single height passive module heat sink, forced air) | RA - Rugged Air-Cooled (Optional) | RC - Rugged Conduction-Cooled (Depending on processor frequency) |
|----------------------------|--|--------------------------------------|--|
| Conformal Coating | Optional | Standard | Standard |
| Airflow | 3 m/s | TBD | NA |
| Temperature | VITA 47-Class AC1 | VITA 47-Class AC3 | VITA 47-Class CC4 |
| Cooling Method | Convection | Convection | Conduction |
| Operating | 0° to +55°C | -40° to +70°C | -40° to +85°C |
| Storage | -45° to +85°C | -45° to +100°C | -45° to +100°C |
| Vibration Sine (Operating) | 20-500 Hz - 2g | 5-2,000 Hz - 3g | 20-2,000 Hz - 5g |
| Random | VITA 47-Class V1 | VITA 47-Class V2 | VITA 47-Class V3 |
| Shock (Operating) | 20g/11 ms Half Sine | 40g/20 ms Half Sine | 40g/20 ms Half Sine |
| Altitude (Operating) | -1,640 to 15,000 ft | -1,000 to 33,000 ft | -1,640 to 50,000 ft |
| Relative Humidity | 90% without condensation | 95% without condensation | 95% without condensation |

Ordering Information

| Article | Order Code | Description |
|--------------------------------------|-------------------|---|
| SA - Standard Commercial | | |
| VX3030 | VX3030-SA22-01000 | Air-cooled 3U VPX Single Board Computer, 2 GHz Intel® Core™ i7, 2 GB DDR3-SDRAM, front: 1" |
| RC - Rugged-Conduction Cooled | | |
| VX3030 | VX3030-RC22-0N000 | Rugged conduction-cooled 3U VPX Single Board Computer, 2 GHz Intel® Core™ i7, 2 GB DDR3-SDRAM |

Note: For 4 GB and 8 GB DDR3-SDRAM, for alternate CPU type and rear I/O equipment, please contact Kontron.

VX3030- Top and Bottom Views

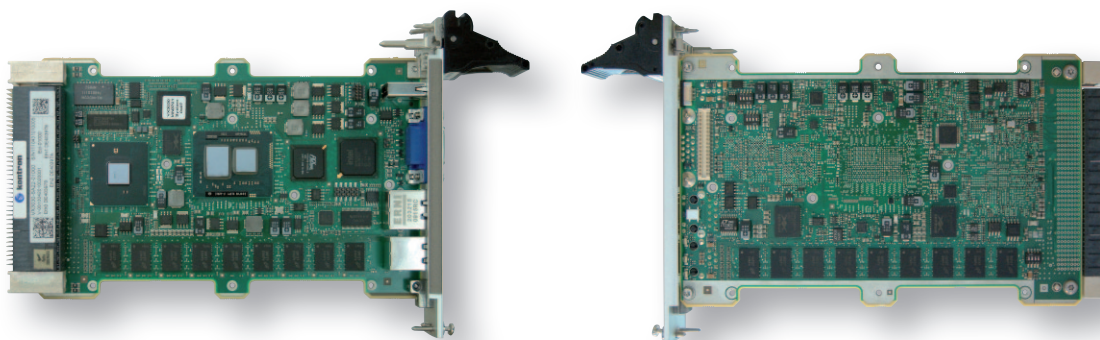

CORPORATE OFFICES

Europe, Middle East & Africa

Oskar-von-Miller-Str. 1
85386 Eching/Munich
Germany
Tel.: +49 (0)8165/ 77 777
Fax: +49 (0)8165/ 77 279
info@kontron.com

North America

14118 Stowe Drive
Poway, CA 92064-7147
USA
Tel.: +1 888 294 4558
Fax: +1 858 677 0898
info@us.kontron.com

Asia Pacific

17 Building, Block #1, ABP.
188 Southern West 4th Ring Road
Beijing 100070, P.R.China
Tel.: + 86 10 63751188
Fax: + 86 10 83682438
info@kontron.cn



#VX3030# 12132011MB
All data is for information purposes only and not guaranteed for legal purposes. Subject to change without notice. Information in this datasheet has been carefully checked and is believed to be accurate; however, no responsibility is assumed for inaccuracies. All brand or product names are trademarks or registered trademarks of their respective owners.