

APPLICATIONS: Utility and industrial truck bodies, industrial work stations, heavy duty machine tools and mechanical devices. Use model 3601 whenever a heavy duty, over travel slide is required.

Three Member, Over Travel
Heavy Duty Slide
Up to 255 lb.* [116 kg.] Capacity

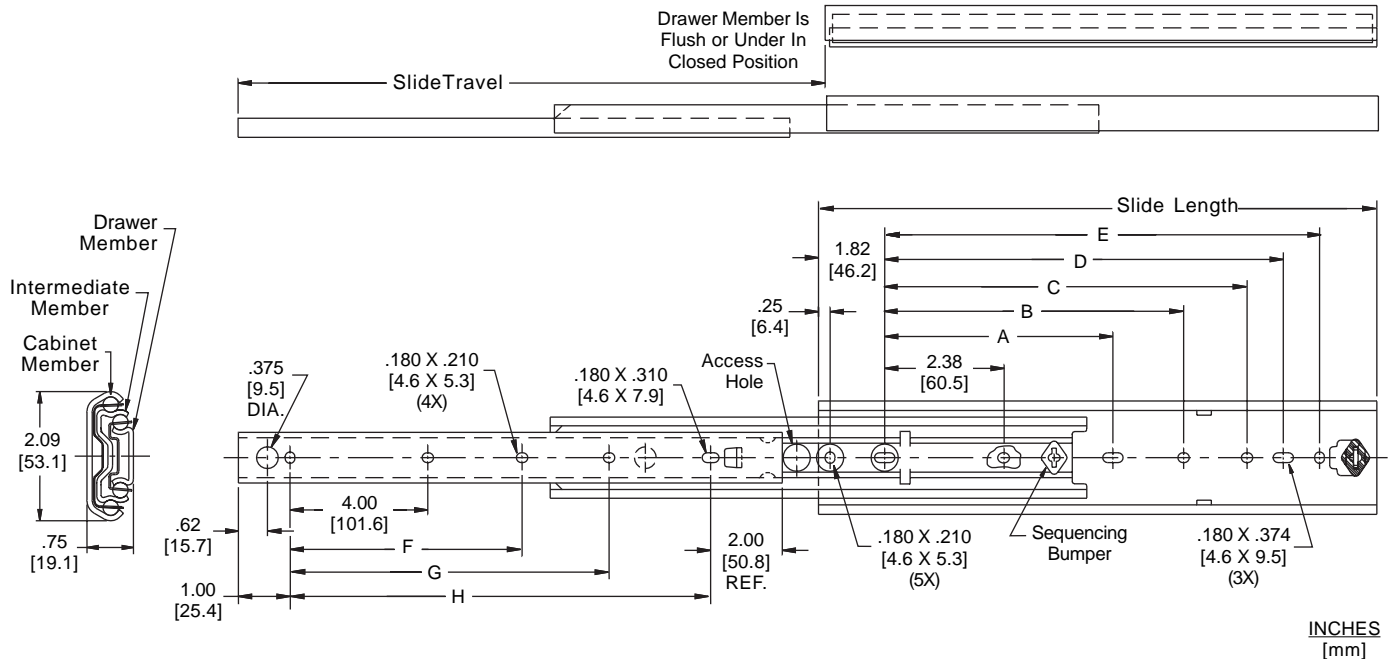

INCHES
[mm]

| | | | |
|-------------------|--|--------------------|--------------------------------|
| Finish | Bright electro-zinc (C) plating | Load Rating | See chart* |
| Length | 12" to 28" [304.85mm to 711.2mm] | Mounting | Side, bracket or hard mounting |
| Travel | Length plus 1" [25.4mm] | Hardware | #8 pan head screws |
| Height | 2.09" [53.1mm] | Movement | Steel ball bearings |
| Side Space | .75" + .030 / - .000 [19.1mm + .76mm / -0.00] | Features | Closed position hold-in detent |

* Load rating based on an 18" slide in a 16" wide drawer cycled 10,000 times.

| Part Number | Slide Length | Slide Travel | Load* Rating lbs [kg] | A | B | C | D | E | F | G | H |
|-------------|---------------|---------------|-----------------------|---------------|---------------|---------------|---------------|---------------|---------------|---------------|---------------|
| 3601-12 | 12.00 [304.8] | 13.00 [330.2] | 255 [116] | - | 5.33 [135.4] | 7.05 [179.1] | 8.05 [204.5] | 9.05 [229.9] | | 6.13 [155.6] | 9.00 [228.6] |
| 3601-14 | 14.00 [355.6] | 15.00 [381.0] | 248 [112] | - | 7.33 [186.2] | 9.05 [229.9] | 10.05 [255.3] | 11.05 [280.7] | | 8.13 [206.4] | 11.00 [279.4] |
| 3601-16 | 16.00 [406.4] | 17.00 [431.8] | 241 [109] | - | 9.33 [237.0] | 11.05 [280.7] | 12.05 [306.1] | 13.05 [331.5] | | 10.13 [257.2] | 13.00 [330.2] |
| 3601-18 | 18.00 [457.2] | 19.00 [482.6] | 234 [106] | 7.50 [190.5] | 11.33 [287.8] | 13.05 [331.5] | 14.05 [356.9] | 15.05 [382.3] | | 12.13 [308.0] | 15.00 [381.0] |
| 3601-20 | 20.00 [508.0] | 21.00 [533.4] | 225 [102] | 8.50 [215.9] | 13.33 [338.6] | 15.05 [382.3] | 16.05 [407.7] | 17.05 [433.1] | 8.00 [203.2] | 14.13 [358.8] | 17.00 [431.8] |
| 3601-22 | 22.00 [558.8] | 23.00 [584.2] | 215 [98] | 9.50 [241.3] | 15.33 [389.4] | 17.05 [433.1] | 18.05 [458.5] | 19.05 [483.9] | 9.00 [228.6] | 16.13 [409.6] | 19.00 [482.6] |
| 3601-24 | 24.00 [609.6] | 25.00 [635.0] | 203 [92] | 10.50 [266.7] | 17.33 [440.2] | 19.05 [483.9] | 20.05 [509.3] | 21.05 [534.7] | 10.00 [254.0] | 18.13 [460.4] | 21.00 [533.4] |
| 3601-26 | 26.00 [660.4] | 27.00 [685.8] | 188 [85] | 11.50 [292.1] | 19.33 [491.0] | 21.05 [534.7] | 22.05 [560.1] | 23.05 [585.5] | 11.00 [279.4] | 20.13 [511.2] | 23.00 [584.2] |
| 3601-28 | 28.00 [711.2] | 29.00 [736.6] | 169 [77] | 12.50 [317.5] | 21.33 [541.8] | 23.05 [585.5] | 24.05 [610.9] | 25.05 [636.3] | 12.00 [304.8] | 22.13 [562.0] | 25.00 [653.0] |

Installation Instructions

Instructions to Bracket Mount

- To ensure proper operation of the slides, make certain that all bracket mounting screws are inserted so the screw heads are inside the slides. (No washers on the inside of the slides.)
- Using mounting kits and brackets, mount brackets to slide cabinet members (largest). For adjustment purposes screw the back brackets on loosely.
- Install slides into EIA rack with (customer supplied) #10-32 screws and secure with bar nuts. Rear adjustment is possible by aligning the back bracket. Do not tighten screws until final adjustment is made.
- Mount slide drawer members (smallest) to the chassis. Position slides 1/8" [3.2mm] from the front edge of the chassis making sure both slides are parallel.
- It may be necessary to use a hoist for positioning and aligning the chassis when the weight exceeds 50 lbs. [23 kg.]. Check slide alignment by opening and closing the chassis. Any sign of binding indicates lateral stress or mis-alignment.
- Adjust slide position until movement is smooth. Tighten all screws and if necessary use more to secure slides and complete installation.

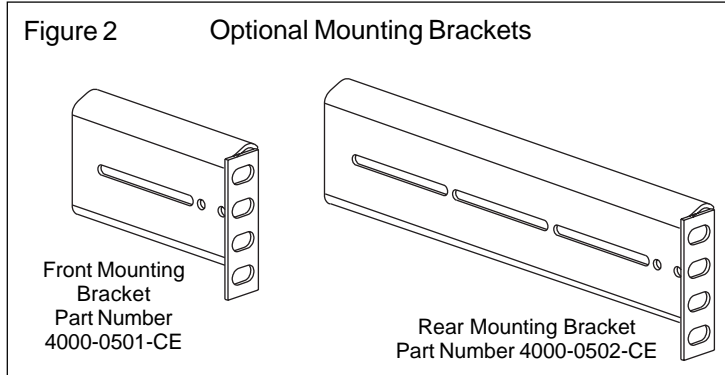
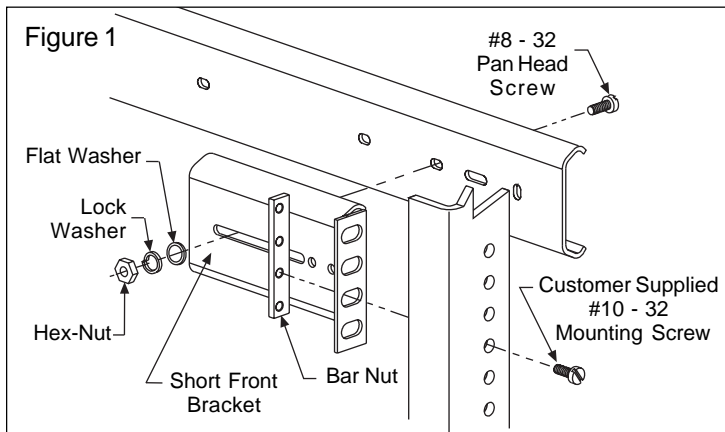

Instructions to Hard Mount

- Follow step 1 of "Bracket Mount" instructions.
- With slides fully extended, install slide cabinet members (largest) into cabinet using # 8 pan head screws through uncovered mounting slots. Move intermediate members to allow access to remaining slots. Ensure slides are parallel.
- Mount slide drawer members (smallest) to chassis. Access covered mounting screw holes by moving the intermediate members away from you. Leave all screws loose for future adjustment. Make sure slides are parallel.
- Follow steps 5 & 6 of "Bracket Mount" instructions.

Slide Ordering Instructions

Complete your slide order for model 3601 by specifying the following:

Total Slides Required 10 each C 3601 -18 D
 Slide Finish _____
 Slide Model _____
 Slide Length _____
 Optional Polybag Packaging _____
Includes screw hardware kit

Optional Mounting Brackets

Optional mounting brackets are ordered as **kits** or **bulk**.

Each **kit** contains enough brackets and hardware to mount one pair of slides. Order kit part number 4180-0220-XE.

Total Kit Required 10 Each 4180-0220-XE
 Kit Part Number _____

Bracket kit includes the following. See Figure 1.

- 2 short front brackets (part number 4000-0501-CE)
 - 2 long rear brackets (part number 4000-0502-CE)
 - 1 bracket hardware kit* (part number 4180-0232-XE)
- (*Kit contains screws, hex-nuts, washers, bar nuts.)

For **bulk**, order 2 front brackets, 2 rear brackets and 1 hardware kit per pair of slides required. See Figure 2.

Total Brackets Required 20 Each 4000-0501-CE (Front)
20 Each 4000-0502-CE (Rear)
 Bracket Part Numbers _____

Total Hardware Kits Required 20 Each 4180-0232-XE
 Hardware Kit* Part Number _____
 (*Kit contains screws, hex-nuts, washers, bar nuts.)

Packaging

Distributor (D) Pack: All lengths are packaged 5 pair per box. Polybag includes one pair of slides packaged with screws. Optional mounting bracket **kits** are ordered separately.

Bulk (P) Pack: Lengths 12" - 20" 7 pair per box
 Lengths 22" - 28" 5 pair per box

Optional mounting brackets are ordered in **bulk**. Order front and rear brackets and hardware kits separate. See Figure 2.

Specifications

Slide members and ball retainers: Cold rolled steel
 Ball bearings: Carburized steel

Note: Specifications, materials, prices, terms, and delivery are subject to change without notice.

Accuride

ACCURIDE INTERNATIONAL INC.

12311 Shoemaker Avenue
 Santa Fe Springs, CA 90670

TEL (562) 903-0200
 FAX (562) 903-0208
 www accuride.com

Manufacturing, Engineering, and Sales
 United States • Germany • Japan • Mexico • United Kingdom