

Features

- FAX and Modem interface (V29)
- Variants available with different line impedances
- Provides reinforced barrier to international PTT requirements
- Transformerless 2-4 Wire conversion.
- Integral Loop Switch
- Dial Pulse and DTMF operation
- Line state detection outputs
- -loop current/ringing outputs
- Single +5V operation, low on-hook power (5mW)
- Full duplex data transmission

Applications

Interface to Central Office or PABX line for:

- Modem
- FAX
- Telemetry

ISSUE 9

October 1997

Ordering Informations

MH88422-1/2/3 26 Pin DIL Package
MH88422BD-1 26 Pin DIL Package

0°C to 70°C

Description

The Mitel MH88422 Data Access Arrangement (D.A.A.) provides a complete interface between data transmission equipment and a telephone line. All functions are integrated into a single thick film hybrid module which provides high voltage isolation, very high reliability and optimum circuit design needing a minimum of external components.

A number of variants are available to meet particular country impedance requirements. The D.A.A. has been designed to meet regulatory approvals requirements in these countries.

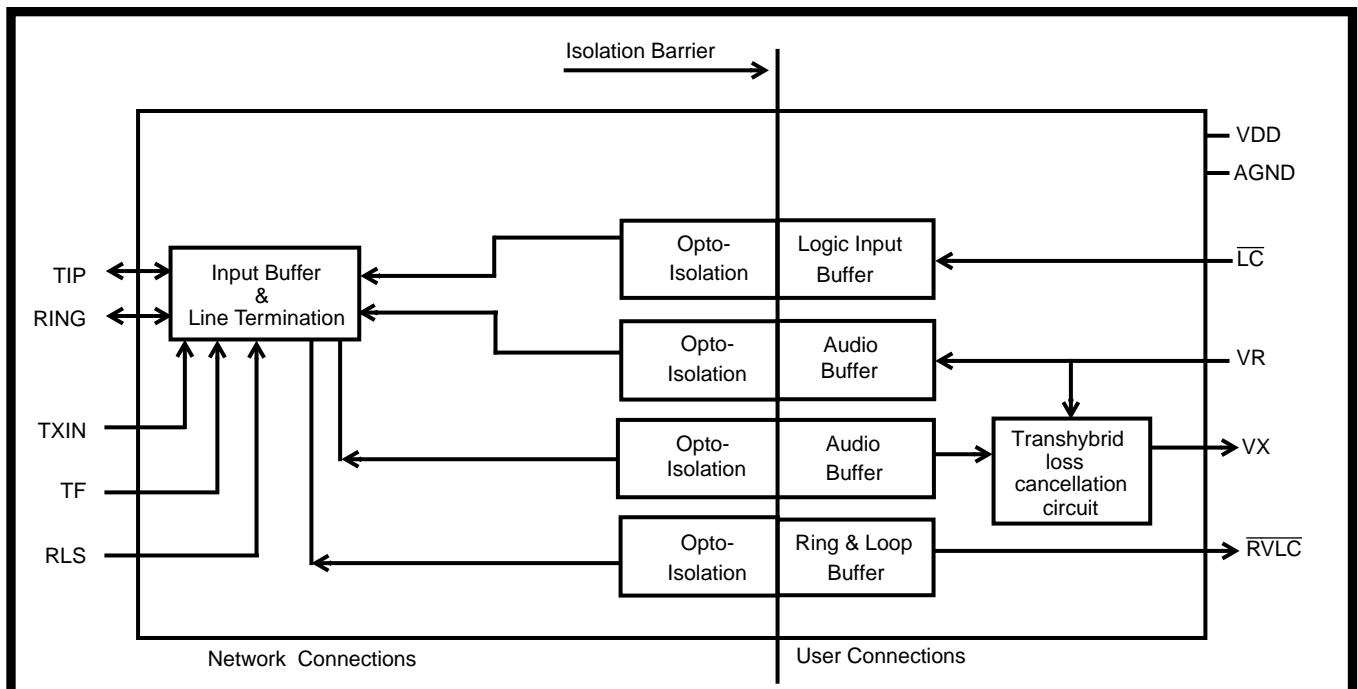

Figure 1 - Functional Block Diagram

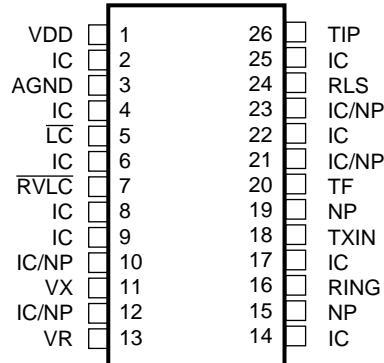

Figure 2 - Pin Connections

Pin Description

Pin #	Name	Description
1	VDD	Positive Supply Voltage. +5V.
2, 4, 6, 8, 9	IC	Internal Connection. This pin is cropped short.
3	AGND	Analog Ground. 4-Wire Ground. Normally connected to System Ground.
5	LC	Loop Control (Input). A logic 0 activates internal circuitry which provides a line termination across Tip and Ring. Used for seizing the line and dial pulsing.
7	RVLC	Ringing Voltage and Current Detect (Output). Indicates the status of loop current and ringing voltage.
10, 12	IC/NP	Internal Connection or No Pin Fitted. This pin is either cropped short or not fitted, depending on the variant. See Note 1
11	VX	Transmit (Output). Analog output to modem/fax chip set.
13	VR	Receive (Input). Analog input to modem/fax chip set.
14, 17	IC	Internal Connection. This pin is cropped short.
15, 19	NP	No Pin Fitted.
16	RING	Ring Lead. Connects to the "Ring" lead of a telephone line.
18	TXIN	Dummy Ringer Connection. Connects to the "Ring" lead of a telephone line through a dummy ringer capacitor.
20	TF	Tip Feed. Connects externally to the RLS pin.
21, 23	IC/NP	Internal Connection or No Pin Fitted. This pin is either cropped short or not fitted, depending on the variant. See Note 1
24	RLS	Ringing Loop Sense. Connects externally to the TF pin.
25	IC	Internal Connection. This pin is cropped short.
26	TIP	Tip Lead. Connects to the "Tip" lead of a telephone line.

Notes:

1. Variant 1, 4 BD-1 - pins 10,12, & 21 are cropped short. Pin 23 is not fitted.
2. Variant 2 - pin 23 is cropped short. Pins 10, 12 & 21 are not fitted.
3. Variant 3 - pins 12 and 21 are cropped short. Pins 10 and 23 are not fitted.

Functional Description

The device is a Data Access Arrangement (D.A.A.). It is used to correctly terminate a 2-Wire analog loop. It provides a signalling link and a 2-4 Wire line interface between an analog loop and subscriber data transmission equipment such as Modems, Facsimiles (Fax's), Remote Metering and Electronic Point of Sale equipment.

Isolation Barrier

The device provides an isolation barrier implemented by using optocouplers. This is a reinforced barrier for an instantaneous power surge of up to 3kV r.m.s., for example a lightning strike. It also provides full isolation for a continuous AC voltage level of up to 250V r.m.s.

External Protection Circuit

Should the input voltage from the line exceed that isolated by the optocoupler, an External Protection Circuit assists in preventing damage to the device and the subscriber equipment. See Figure 3.

Line Termination

When Loop Control (\overline{LC}) is at a logic 0, a line termination is applied across Tip and Ring. The device can be considered off-hook and DC loop current will flow. The line termination consists of both a DC line termination and an AC input impedance.

When \overline{LC} is at a logic 1, a Dummy Ringer is applied across Tip and Ring. The device can be considered on-hook and negligible DC current will flow. The dummy ringer is an AC load, which represents a telephone's mechanical ringer.

DC Line Termination

When \overline{LC} is at a logic 0, an active termination is applied across Tip and Ring, at which time it can be considered to be in an off-hook state. This is used to terminate an incoming call, seize the line for an outgoing call, or if it is applied and disconnected at the required rate, can be used to generate dial pulses. This termination resembles approximately 300 Ω resistance, which is loop current dependent.

Input Impedance

The MH88422 is available in a number of different variants each of which has its own fixed Tip-Ring AC input impedance (Z_{in}). Each variant is identified by the final digit in its part number, as listed below. Also shown are the countries whose PTT requirements match these impedances.

MH88422-1 $Z_{in} = 220\Omega + 820\Omega // 120nF$
Australia / South Africa / Spain

MH88422BD-1 $Z_{in} = 220\Omega + 820\Omega // 115nF$
German BAPT ZV5

MH88422-2 $Z_{in} = 600\Omega$
North America

MH88422-3 $Z_{in} = 370\Omega + 620\Omega // 310nF$
UK / New Zealand

Dummy Ringer

This device supports a dummy ringer option which can be configured by the inclusion of external components. Further details relating to component values and configuration can be obtained from MSAN-154. For example, Figure 3 shows capacitor C2 which if set to 1.8 μF would meet the New Zealand dummy ringer requirements.

2-4 Wire Conversion

The device converts the balanced 2-Wire input, presented by the line at Tip and Ring, to a ground referenced signal at VX, as required by modem/fax chip sets.

Conversely the device converts the ground referenced signal input at VR, to a balanced 2-Wire signal across Tip and Ring.

During full duplex transmission, the signal at Tip and Ring consists of both the signal from the device to the line and the signal from the line to the device. The signal input at VR, being sent to the line, must not appear at the output VX. In order to prevent this, the device has an internal cancellation circuit. The measure of attenuation is Transhybrid Loss (THL).

The Transmit (VX) and Receive (VR) signals are ground referenced (AGND), and biased to 2.5V. The

device must be in the off-hook condition for transmission or reception to take place.

Transmit Gain

The Transmit Gain of the MH88422 is the gain from the differential signal across Tip and Ring to the ground referenced signal at VX. The internal Transmit Gain of the device is fixed and depends on the variant as shown in the AC Electrical Characteristics table. For the correct gain, the Input Impedance of the MH88422 variant used, must match the specified line impedance.

By adding an external potential divider to VX, it is possible to reduce the overall gain in the application. The output impedance of VX is approximately 10Ω and the minimum resistance from VX to ground should be 2kΩ.

Example: If R1 = R2 = 2kΩ, in Figure 3, the gain would reduce by 6.0dB.

Receive Gain

The Receive Gain of the MH88422 is the gain from the ground referenced signal at VR to the differential signal across Tip and Ring. The internal Receive Gain of the device is fixed as shown in the AC Electrical Characteristics table. For the correct gain, the Input Impedance of the MH88422 variant used, must match the specified line impedance.

The input impedance to ground of VR is 47kΩ and this can be used with an external series resistor to form a potential divider and reduce the overall gain in the application.

Example: If R3 = 100kΩ, in Figure 3, the Gain would reduce by 3.0dB.

Supervisory Features

The device is capable of monitoring the line conditions across Tip and Ring, this is shown in Figure 3. The Ringing Voltage Loop Current detect pin (\overline{RVLC}), indicates the status of the device. The \overline{RVLC} output is at logic 0 when loop current flows, indicating that the MH88422 is in an off hook state.

When the device is generating dial pulses, the \overline{RVLC} pin outputs a TTL pulse at the same rate.

An AC ringing voltage across Tip and Ring will cause \overline{RVLC} to output a TTL pulse at double the ringing frequency with an envelope determined by the ringing cadence.

Mechanical Data

See Figure 10, for details of the mechanical specification.

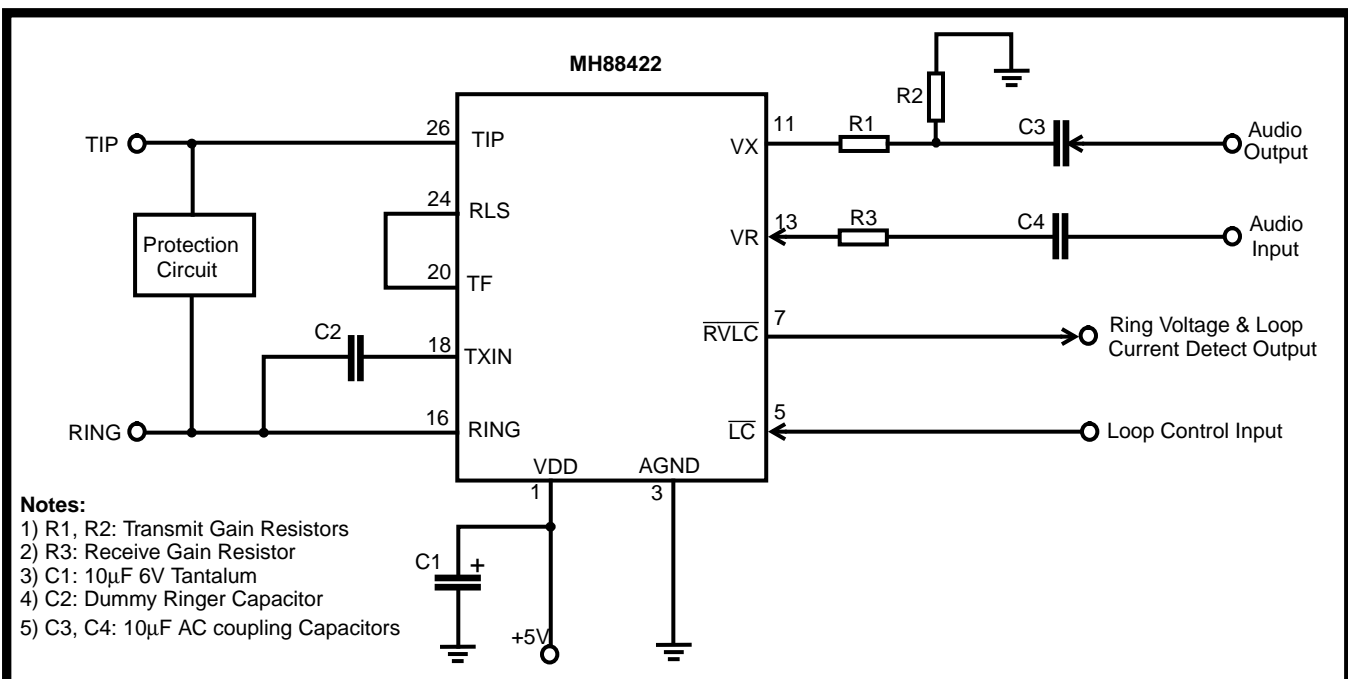

Figure 3 - Typical Application Circuit

Absolute Maximum Ratings* - All voltages are with respect to AGND unless otherwise specified.

	Parameter	Symbol	Min	Max	Units
1	DC Supply Voltage	V_{DD}	-0.3	6	V
2	Storage Temperature	T_S	-55	+125	°C
3	DC Loop Voltage	V_{BAT}	-110	+110	V
4	Ringing Voltage - 2 variant - all other variants	V_R V_R	- -2	130 120	Vrms Vrms
5	Loop Current	I_{Loop}	-	90	mA

*Exceeding these values may cause permanent damage. Functional operation under these conditions is not implied.

Recommended Operating Conditions

	Parameter	Sym	Min	Typ [‡]	Max	Units	Test Conditions
1	DC Supply Voltages	V_{DD}	4.75	5.0	5.25	V	
2	Operating Temperatures	T_{OP}	0	25	70	°C	
3	Ringing Voltage	V_R		75	90	Vrms	

‡ Typical figures are at 25°C with nominal +5V supply and are for design aid only

Loop Electrical Characteristics[†]

	Characteristics	Sym	Min	Typ [‡]	Max	Units	Test Conditions
1	Ringing Voltage -1 Variant Only No Detect Detect	VR	35		17	Vrms Vrms	Externally Adjustable - See MSAN-154
	BD-1 Variant Only No Detect Detect		32		15	Vrms Vrms	
	All other Variants No Detect Detect		14		7	Vrms Vrms	
2	Ringing Frequency BD-1 Variant Only All other Variants		23 15		28 68	Hz Hz	
3	Operating Loop Current BD-1 Variant Only All other Variants		20 15		80 80	mA mA	
4	Off-Hook DC Voltage -1 Variant		6.0		28.8	V V	Test circuit as Fig 4 $I_{Loop}=19mA$ (See Note 1) $I_{Loop}=60mA$ $I_{Loop}=15mA$ $I_{Loop}=20mA$ (See Note 2) $I_{Loop}=26mA$ $I_{Loop}=15mA$ (See Note 3) $I_{Loop}=90mA$ $I_{Loop}=20mA$ (See Note 4) $I_{Loop}=50mA$
	-2 Variant		2.4 3.1		6.0 6.0 7.8	V V V	
	-3 Variant		6.0		9.0 14.0	V V	
	BD-1 Variant		6.0 6.0		10.8 27	V V	

Loop Electrical Characteristics † (continued)

5	Leakage Current (Tip or Ring to AGND)				10	μA	100V DC
6	Leakage Current on-hook (Tip to Ring)			9	10	μA	V _{BAT} = -50V
7	DC Resistance during dialling -1 Variant All other Variants			200 260	220 280	Ω Ω	I _{Loop} = 20 - 40 mA
8	Dial Pulse Distortion BD-1 Variant ON OFF All other Variants ON OFF		0 0 0 0	+1 +1 +2 +2	+2 +2 +4 +4	ms ms ms ms	

† Electrical Characteristics are over Recommended Operating Conditions unless otherwise stated.

‡ Typical figures are at 25°C with nominal + 5V supplies and are for design aid only.

Note 1: Refer to FTZ 1TR2 section 2.2

Note 2: Refer to EIA/TIA 464 section 4.1.1.4.4

Note 3: Refer to BS6305 section 4.3.1

Note 4: Refer to ZV5 Annex 1

DC Electrical Characteristics †

		Characteristics	Sym	Min	Typ‡	Max	Units	Test Conditions
1		Supply Current	I _{DD}		1	5	mA	V _{DD} = 5.0V, On-hook
2	\overline{RVLC}	Low Level Output Voltage High Level Output Voltage	V _{OL} V _{OH}	2.4		0.4	V V	I _{OL} = 4mA I _{OH} = 0.4mA
3	\overline{LC}	Low Level Input Voltage High Level Input Voltage Low Level Input Current High Level Input Current	V _{IL} V _{IH} I _{IL} I _{IH}	2.0		0.8 -60 60	V V μA μA	V _{IL} = 0.0V V _{IH} = 5.0V

† Electrical Characteristics are over Recommended Operating Conditions unless otherwise stated.

‡ Typical figures are at 25°C with nominal + 5V supplies and are for design aid only.

AC Electrical Characteristics † - MH88422 All Variants

	Characteristics	Sym	Min	Typ [‡]	Max	Units	Test Conditions
1	Input Impedance VR			47k		Ω	
2	Output Impedance at VX			10		Ω	
3	Receive Gain (VR to 2-Wire)		2.5	3.5	4.6	dB	Test circuit as Fig 6 Input 0.5V at 1kHz
4	Frequency Response Gain (relative to Gain @ 1kHz)						
	All Variants		-1 -1	0 0	+1 +1	dB dB	300Hz 3400Hz
5	Signal Output Overload Level at 2-Wire at Vx		+2.0 +2.0	+3.0 +3.0		dBm dBm	THD ≤ 5% @ 1kHz I _{Loop} = 20 to 40mA
6	Total Harmonic Distortion BD-1 Variant at 2-Wire All other Variants at 2-Wire All Variants at VX	THD		1.2 1.2 1.2	2.0 2.5 2.0	% % %	Input -3.5dBm at 1kHz
7	Power Supply Rejection Ratio BD-1 Variant at 2-Wire at VX All other Variants at 2-Wire at VX	PSRR	18 18	40 40		dB dB dB dB	Ripple 0.1Vrms 1kHz on V _{DD}
8	Transhybrid Loss	THL	6	20		dB	Test circuit as Fig 6 Input -3.5dBm, 300-3400Hz at V _R

† Electrical Characteristics are over Recommended Operating Conditions unless otherwise stated.

‡ Typical figures are at 25°C with nominal +5V and are for design aid only.

Note 1: All of the above test conditions use a test source impedance which matches the device's impedance.

Note 2: dBm is referenced to 600Ω unless otherwise stated.

AC Electrical Characteristics[†] - MH88422-1

	Characteristics	Sym	Min	Typ [‡]	Max	Units	Test Conditions
1	2-Wire Input Impedance (220Ω + 820Ω //120nF)	Zin		900		Ω	@ 1kHz
2	Return Loss at 2-Wire (220Ω + 820Ω //120nF)	RL	20 20 20	22 24 26		dB dB dB	Test circuit as Fig 7 300-500Hz 500-2500Hz 2500-3400Hz
3	Longitudinal to Metallic Balance		40 55 53	65 60 60		dB dB dB	Test circuit as Fig 8 50-300Hz 300-1000Hz 1000-4000Hz
4	Idle Channel Noise at 2-Wire at VX	Nc		-79 -73	-72 -58	dBmp dBmp	
5	Transmit Gain (2-Wire to Vx)		-1.4	-0.4	0.9	dB	Test circuit as Fig 5 Input 0.5V @ 1kHz Off -Hook
6	Frequency Response Gain (relative to Gain @ 1kHz)		-1.6 -2.1	-0.6 -0.5	0.4 0.9	dB dB	300Hz 3400Hz

[†] Electrical Characteristics are over Recommended Operating Conditions unless otherwise stated.

[‡] Typical figures are at 25°C with nominal +5V and are for design aid only

Note 1: All of the above test conditions use a test source impedance which matches the device's impedance.

AC Electrical Characteristics[†] - MH88422-2

	Characteristics	Sym	Min	Typ [‡]	Max	Units	Test Conditions
1	2-Wire Input Impedance (600Ω)	Zin		600		Ω	@ 1kHz
2	Return Loss at 2-Wire (Reference 600Ω)	ERL SFRL	20 14	30 19		dB dB	Test circuit as Fig 7 500-2500Hz 200-3200Hz
3	Longitudinal to Metallic Balance		58 53	60 55		dB dB	Test circuit as Fig 8 200-1000Hz 1000-3000Hz
	Metallic to Longitudinal Balance		60 40			dB dB	Test circuit as Fig 9 200-1000Hz 1000-4000Hz
4	Idle Channel Noise at 2-Wire at VX	Nc		13 13	20 20	dBrnC dBrnC	
5	Transmit Gain (2-Wire to Vx)		-1.4	-0.4	0.9	dB	Test circuit as Fig 5 Input 0.5V @ 1kHz Off- Hook
6	Frequency Response Gain (relative to Gain @ 1kHz)		-1.6 -2.1	-1.3 -0.5	0.4 0.9	dB dB	200Hz 3400Hz

[†] Electrical Characteristics are over Recommended Operating Conditions unless otherwise stated.

[‡] Typical figures are at 25°C with nominal +5V supply and are for design aid only

Note 1: All of the above test conditions use a test source impedance which matches the device's impedance.

AC Electrical Characteristics[†] - MH88422-3

	Characteristics	Sym	Min	Typ [‡]	Max	Units	Test Conditions
1	2-Wire Input Impedance (370Ω + 620Ω // 310nF)	Zin		700		Ω	@ 1kHz
2	Return Loss at 2-Wire (370Ω + 620Ω // 310nF)	RL	16	20		dB	Test circuit as Fig 7 200-4000Hz
3	Longitudinal to Metallic Balance		50	60		dB	Test circuit as Fig 8 300-3400Hz
4	Idle Channel Noise at 2-Wire at VX	Nc		-80 -80	-70 -68	dBmp dBmp	
5	Transmit Gain (2-Wire to Vx)		-1.4	-0.4	0.9	dB	Test circuit as Fig 5 Input 0.5V @ 1kHz Off-Hook
6	Frequency Gain (relative to gain @ 1kHz)		-1.6 -2.1	-1.3 -0.5	0.4 0.9	dB dB	300Hz 3400Hz

[†]AC Electrical Characteristics are over Recommended Operating Conditions unless otherwise stated.

[‡]Typical figures are at 25°C with nominal +5V and are for design aid only.

Note 1: All of the above test conditions use a test source impedance which matches the device's impedance.

AC Electrical Characteristics[†] - MH88422BD-1

	Characteristics	Sym	Min	Typ [‡]	Max	Units	Test Conditions
1	2-Wire Input Impedance (220Ω + 820Ω // 115nF)	Zin		900		Ω	@ 1kHz
2	Return Loss at 2-Wire (220Ω + 820Ω // 115nF)	RL	16	22		dB	Test circuit as Fig 7 300-3400Hz Ref ZV5 Sec 2.5.2 and 2.8.3
3	Longitudinal to Metallic Balance		30 40 46	65 60 60		dB dB dB	Test circuit as Fig 8 50-300Hz 300-600Hz 600-4000Hz Ref ZV5 Sec 2.8.2
4	Idle Channel Noise at 2-Wire at VX	Nc		-84 -75	-70 -70	dBmp dBmp	
5	Transmit Gain (2-Wire to Vx)		-1.4	-0.4	0.9	dB	Test circuit as Fig 5 Input 0.5V @ 1kHz Off-Hook
6	Frequency Gain (relative to gain @ 1kHz)		-1.6 -1.2	-1.3 -0.5	-0.4 0	dB dB	300Hz 3400Hz

[†]AC Electrical Characteristics are over Recommended Operating Conditions unless otherwise stated.

[‡]Typical figures are at 25°C with nominal +5V and are for design aid only.

Note 1: All of the above test conditions use a test source impedance which matches the device's impedance.

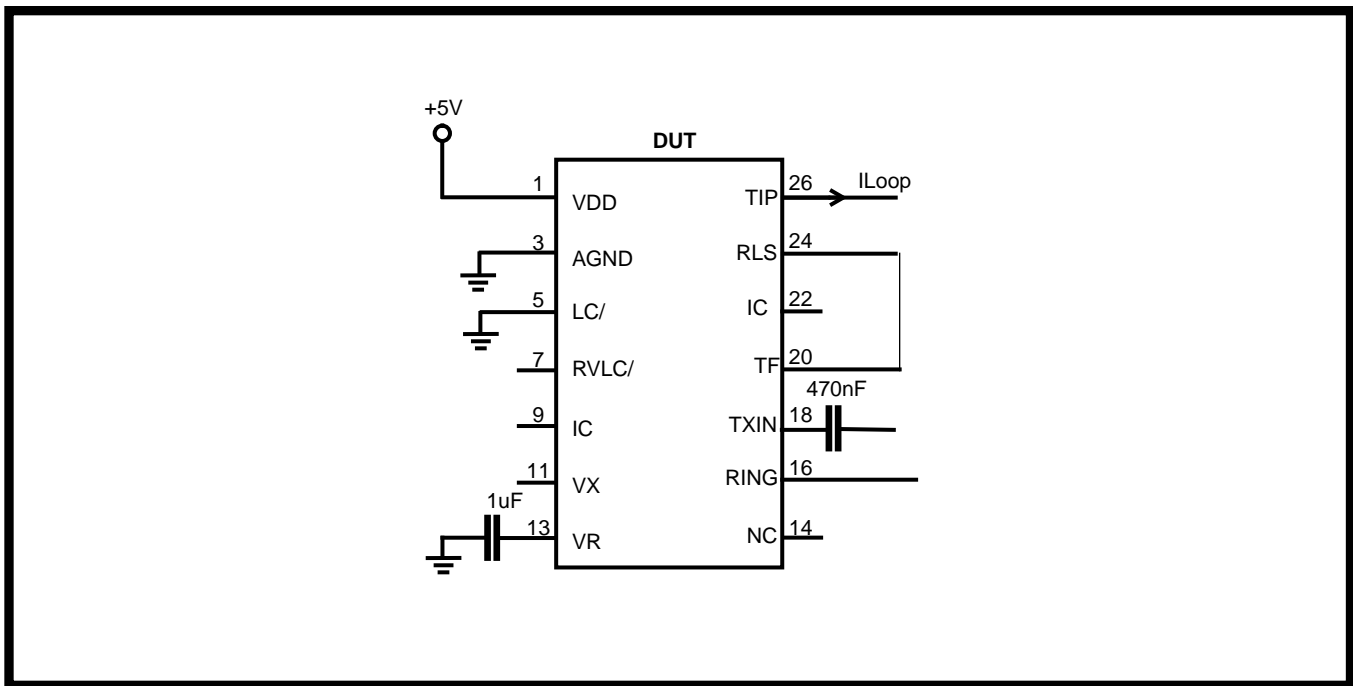
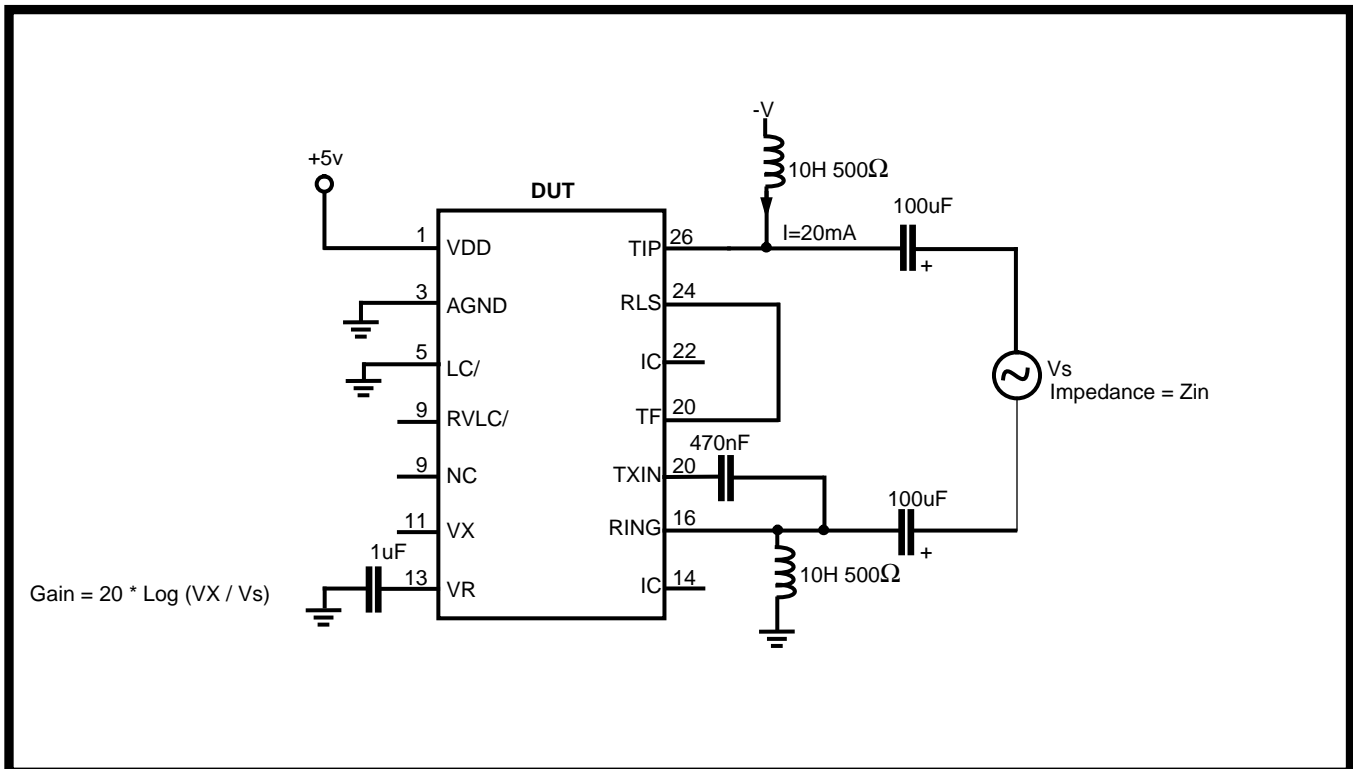

Figure 4 - Test Circuit 1



Gain = 20 * Log (VX / Vs)

Figure 5 - Test Circuit 2

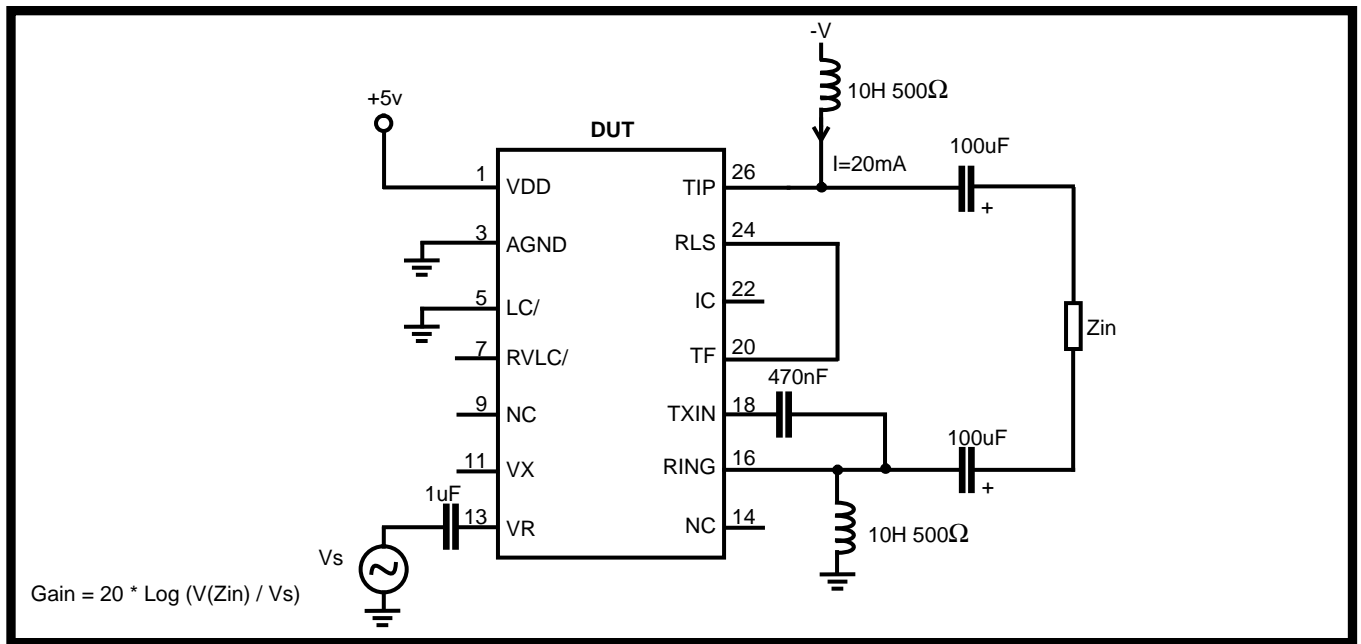

Figure 6 - Test Circuit 3

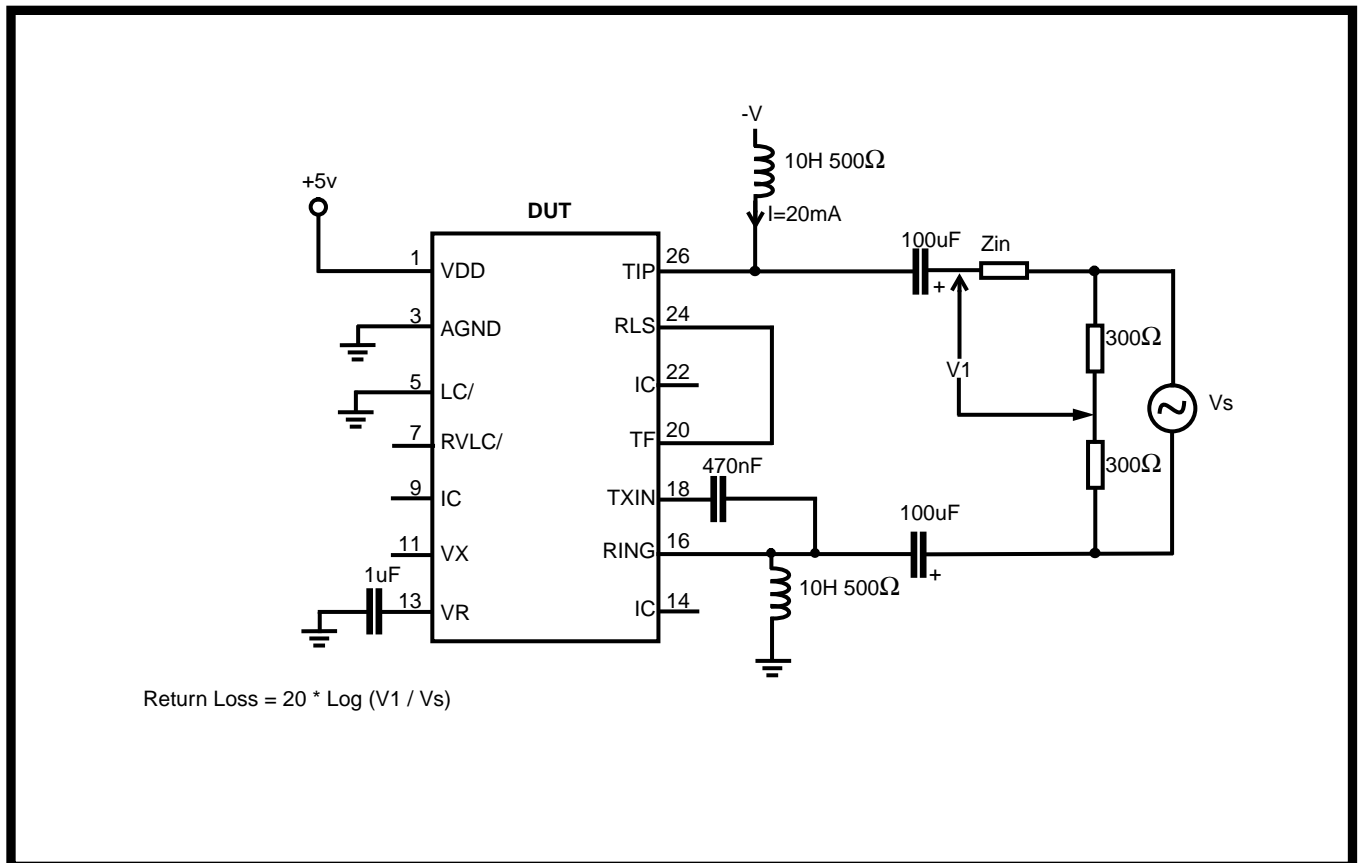

Figure 7 - Test Circuit 4

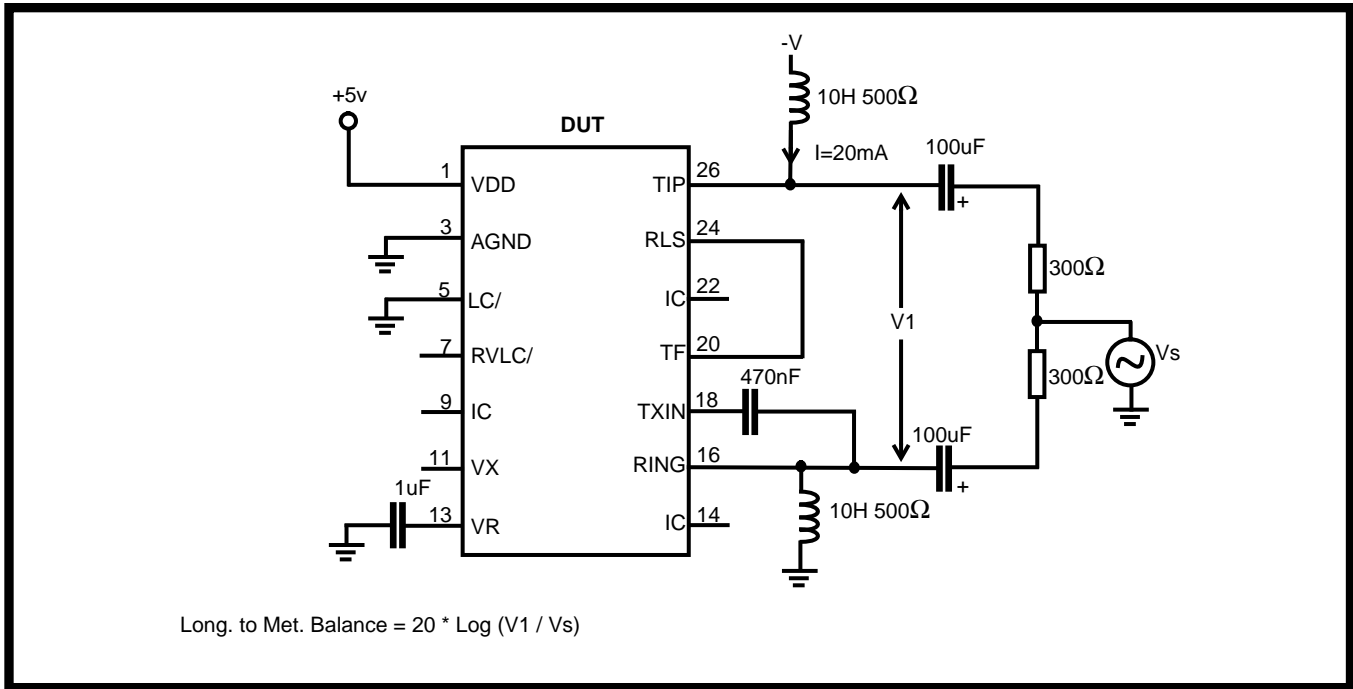

Figure 8 - Test Circuit 5

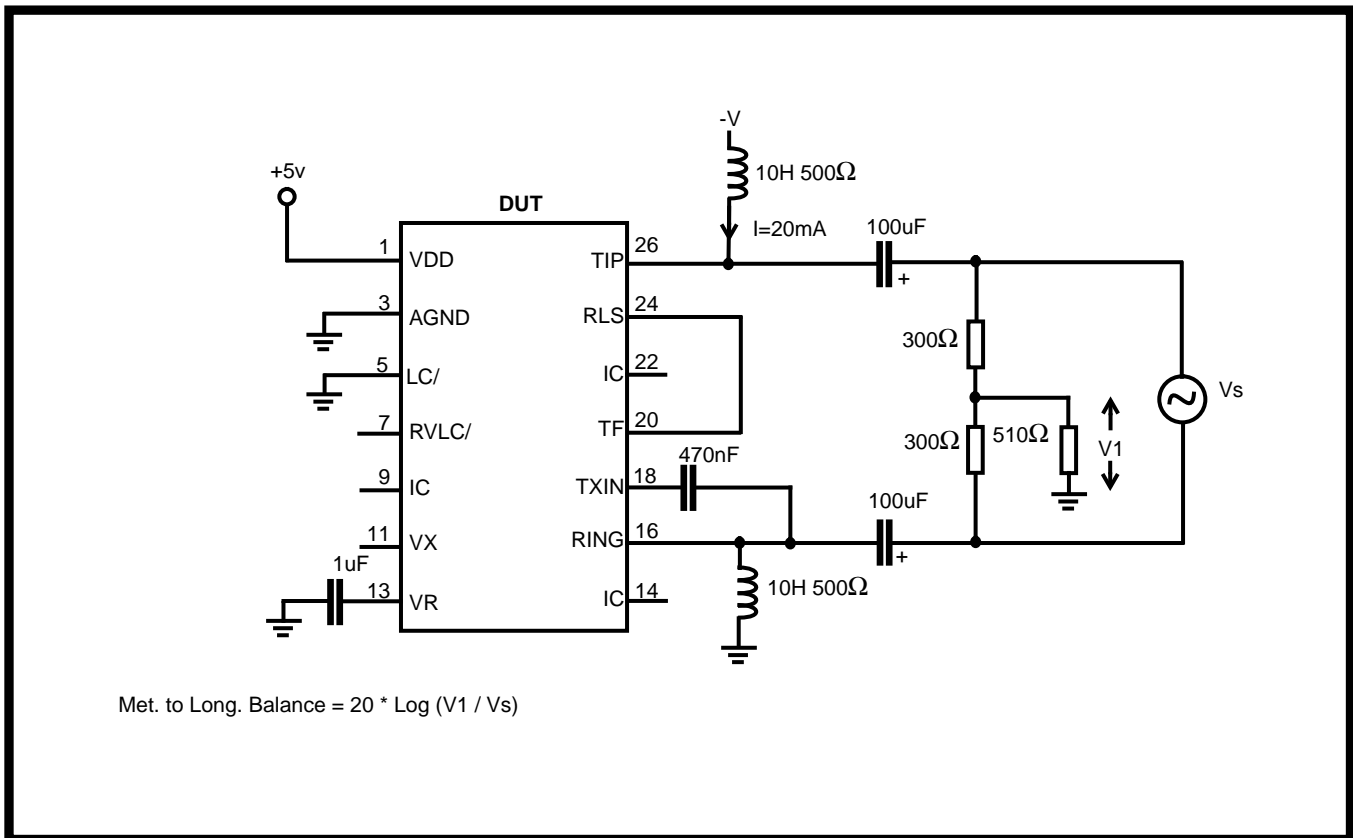

Figure 9 - Test Circuit 6

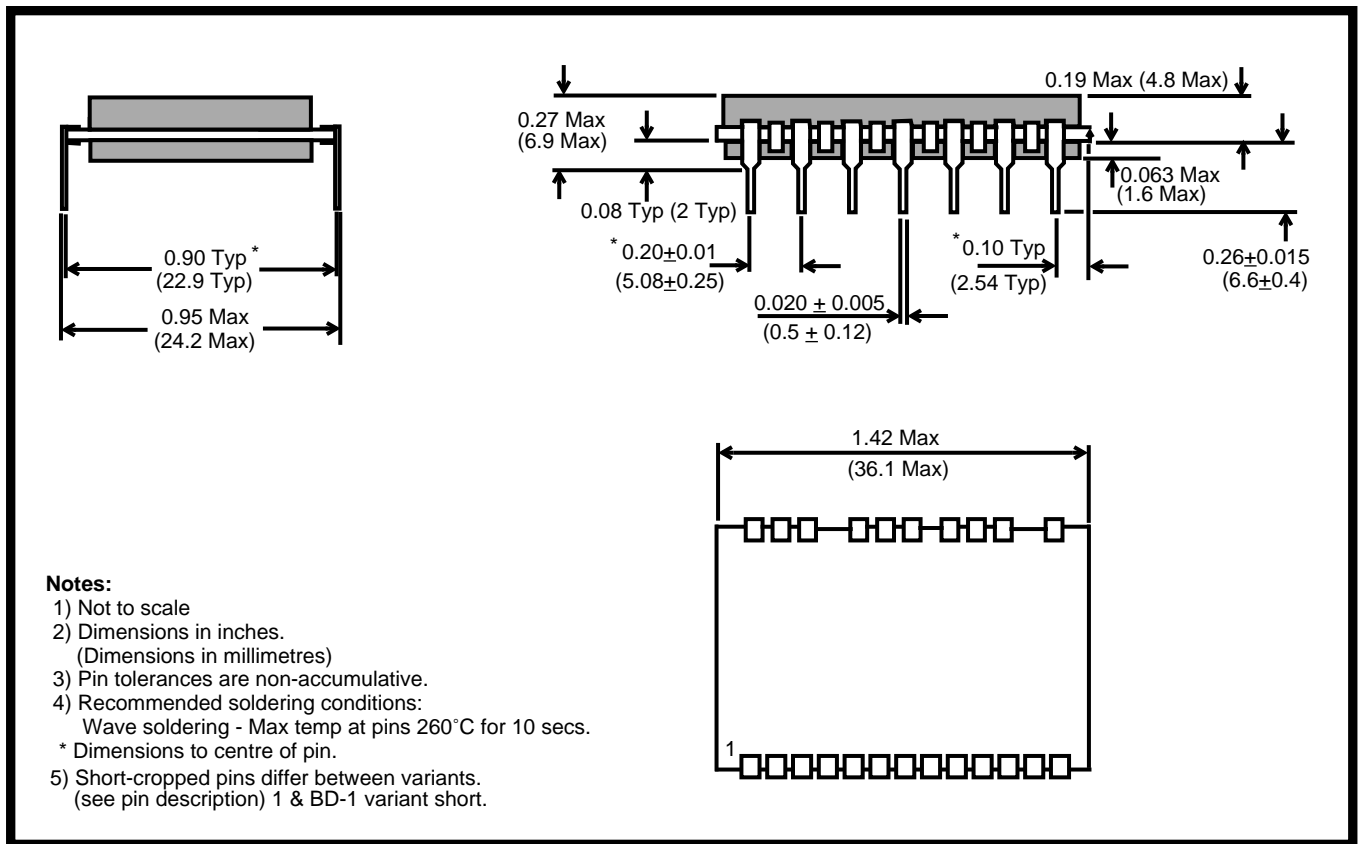

Figure 10 - Mechanical Data for 26-Pin DIL Hybrid

Notes: