

# General Standards Corporation

## High Performance Bus Interface Solutions

### PC104P-16AI64

*64-Channel, 16-Bit Analog Input PC104 Plus Board  
With 500 KSPS Input Conversion Rate*

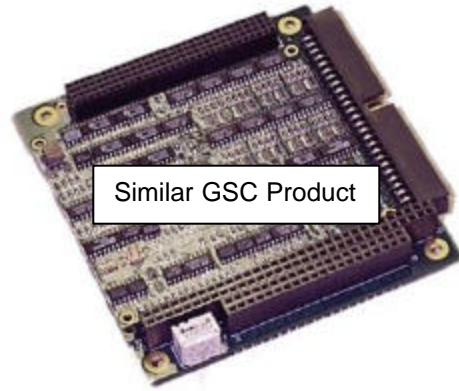

#### ***Features Include:***

- 64 Single-ended or 32 Differential 16-Bit Scanned Analog Input Channels
- Sample Rates to 500K-Samples per Second;
- Up to 125KSPS per channel in Scan Mode, 500KSPS in Single-Channel Mode
- Input Ranges Selectable as  $\pm 10V$ ,  $\pm 5V$  or  $\pm 2.5V$
- Data Buffered through a 64K-sample FIFO?
- Continuous and Burst (One-Shot) Input Modes
- Sync Input/Output (Alternate Function for Channels 62,63) ;
- Scan Sizes from 4 to 64 Channels-per-Scan; or Single-Channel sampling of any Channel
- Internal Rate Generator Implements a 32-Bit Divider
- Conversion Rate Adjustable from 0.01 to 500K Conversions-per-Second
- Internal Autocalibration upon command
- DMA Engine Minimizes Host I/O Overhead
- Each Input Channel Buffered for Minimum Crosstalk and Input Bias Current
- Completely Software-Configurable; No Field Jumpers
- Single-width PMC Form Factor with EMI Shield and Panel Bezel

#### ***Applications Include:***

- |                            |                       |                              |
|----------------------------|-----------------------|------------------------------|
| ✓ Acoustics Analysis       | ✓ Voltage Measurement | ✓ Automatic Test Equipment   |
| ✓ Analog Inputs            | ✓ Process Monitoring  | ✓ Audio Waveform Analysis    |
| ✓ Data Acquisition Systems | ✓ Industrial Robotics | ✓ Environmental Test Systems |

---

## General Standards Corporation

8302A Whitesburg Drive · Huntsville, AL 35802

Phone: (256) 880-8787 or (800) 653-9970

FAX: (256) 880 0700

# General Standards Corporation

## High Performance Bus Interface Solutions

### Functional Description:

The PC104P-16AI64 board is a scanning analog digitizer that performs high-speed sampling and 16-bit A/D conversion of as many as 64 single-ended or 32 differential analog input channels. The resulting 16-bit sampled data is available to the PCI bus through a 64K-Sample FIFO buffer. All operational parameters are software configurable.

The analog inputs can be sampled in scans of 4, 8, 16, 32 or 64 single-ended channels, or in scans of 4, 8, 16 or 32 differential channels. The scan rate can be controlled internally up to 125,000 scans per second for a 4-channel scan, or any single channel can be sampled at 500,000 samples per second. A Sync input/output signal can replace Channels 62,63 to permit multiple boards to perform synchronous scanning. All inputs are buffered to avoid the high cross talk and input bias currents common with nonbuffered multiplexers.

The internal auto calibration utility uses hardware D/A converters to correct for offset and gain errors in the input signal path, and eliminates the missing codes that are inevitably introduced when software correction methods are used. A selftest switching network routes calibration signals through the input multiplexer to the A/D converter to support internal auto calibration, and permits board integrity to be verified by the host. Auto calibration is performed automatically after reset or upon demand from the PCI bus, and calibrates the offset and gain of the converter to a precision internal reference voltage.

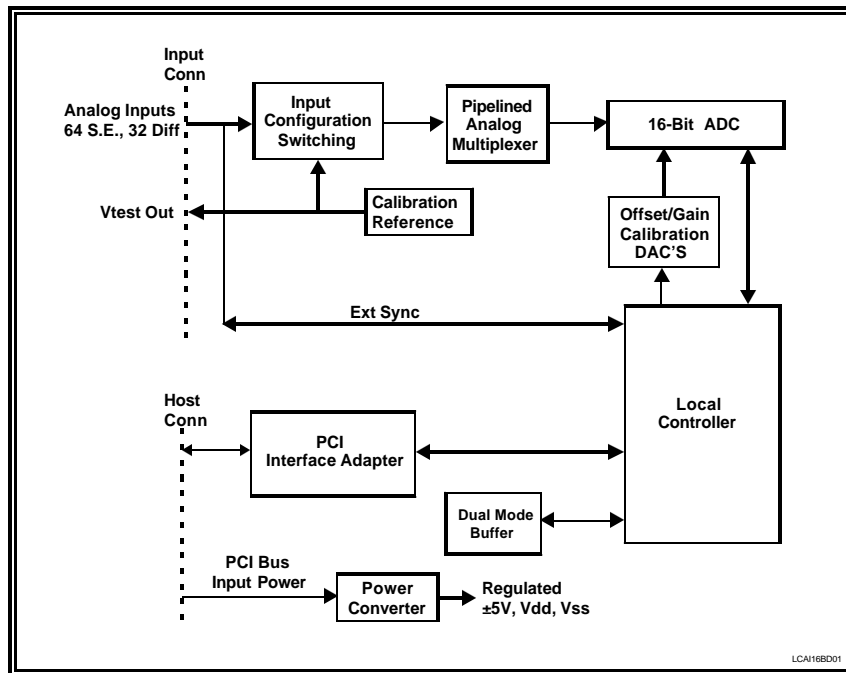

Figure 1. PC104P-16AI64; Functional Organization

The board is functionally compatible with the IEEE PCI local bus specification Revision 2.1, and supports the "plug-n-play" initialization concept. System connections are made at the front panel through a high-density 68-pin connector. Power requirements consist of +5 VDC, in compliance with the PCI specification, and operation over the specified temperature range is achieved with conventional convection cooling.

**General Standards Corporation**

8302A Whitesburg Drive · Huntsville, AL 35802

Phone: (256) 880-8787 or (800) 653-9970

FAX: (256) 990-0700

# General Standards Corporation

## High Performance Bus Interface Solutions

### ELECTRICAL SPECIFICATIONS

At +25 °C, with specified operating voltages

#### □ Input Characteristics:

Configuration:	64 single-ended or 32 differential analog input channels
Voltage Ranges:	Software configurable as $\pm 10$ Volts, $\pm 5$ Volts or $\pm 2.5$ Volts; or optionally factory configured for a fixed range of $\pm 10$ Volts, $\pm 5$ Volts or $\pm 2.5$ Volts
Input Impedance:	1.0 Megohm typical.
Common Mode Rejection:	60 dB typical, DC-60 Hz (Differential inputs)
Common Mode Range:	Same as selected voltage range, with zero normal mode signal (Diff inputs)
Bias Current:	Less than 80 nanoamps
Crosstalk Rejection:	85dB typical, DC-10kHz
Overvoltage Protection:	$\pm 30$ Volts with power applied*; $\pm 15$ Volts with power removed.

\* Inputs 62,63 (Alternate function TTL Sync I/O) limited to -0.5 to +7.0 Volts

#### □ Transfer Characteristics:

Resolution:	16 Bits (0.0015 percent of FSR)												
Maximum Sample Rate:	300K conversions per second												
Scan Rate:	Adjustable internally from 0.01 to 75K scans per second; 300KSPS in single-channel mode.												
Channels per scan:	8, 16, 32 or 64 Single-ended channels; 4, 8, 16 or 32 differential channels. Or, one channel in single-channel mode.												
DC Accuracy: (Maximum composite error after autocalibration)	<table><thead><tr><th>Range</th><th>Midscale Accuracy</th><th><math>\pm</math>Fullscale Accuracy</th></tr></thead><tbody><tr><td><math>\pm 10V</math></td><td><math>\pm 3mv</math></td><td><math>\pm 4mv</math></td></tr><tr><td><math>\pm 5V</math></td><td><math>\pm 2mv</math></td><td><math>\pm 3mv</math></td></tr><tr><td><math>\pm 2.5V</math></td><td><math>\pm 1mv</math></td><td><math>\pm 2mv</math></td></tr></tbody></table>	Range	Midscale Accuracy	$\pm$ Fullscale Accuracy	$\pm 10V$	$\pm 3mv$	$\pm 4mv$	$\pm 5V$	$\pm 2mv$	$\pm 3mv$	$\pm 2.5V$	$\pm 1mv$	$\pm 2mv$
Range	Midscale Accuracy	$\pm$ Fullscale Accuracy											
$\pm 10V$	$\pm 3mv$	$\pm 4mv$											
$\pm 5V$	$\pm 2mv$	$\pm 3mv$											
$\pm 2.5V$	$\pm 1mv$	$\pm 2mv$											
Integral Nonlinearity:	$\pm 0.007$ percent of FSR, typical												
Differential Nonlinearity:	$\pm 0.003$ percent of FSR, maximum												

#### □ Analog Input Operating Modes and Controls

Input Data Buffer:	64K-sample FIFO, with Channel-00 tag.
Analog Input Modes:	Continuous Scan: Analog inputs are scanned continuously. Burst Scan: Each scan is initiated either by the internal rate generator, or by a hardware TTL input or a software sync input Single Channel: Any single selected channel is sampled continuously Selftest: Autocalibration and Selftest modes

---

## General Standards Corporation

8302A Whitesburg Drive · Huntsville, AL 35802

Phone: (256) 880-8787 or (800) 653-9970

FAX: (256) 880-0700

# General Standards Corporation

## High Performance Bus Interface Solutions

Rate Generator: Programmable from 0.01 - 500,000 conversion per second. External triggering is available through Channel 62,63 pins.

Input Data Format: Selectable as offset binary or as two's complement

### PCI INTERFACE

- Compatibility:** Conforms to PCI Specification 2.1, with D32 read/write transactions.  
Supports "plug-n-play" initialization.  
Provides one multifunction interrupt.  
Supports DMA transfers as bus master.

### MECHANICAL AND ENVIRONMENTAL SPECIFICATIONS

- Power Requirements**

+5VDC  $\pm$ 0.2 VDC at 1.0 Amps, maximum, 1.1 Amps typical  
Power Dissipation: 7.0 Watts maximum; 5.5 Watts typical

- Physical Characteristics** (Overall, excluding spacers):

Height: 23.3 mm (0.92 in)  
Width: 94.0 mm (3.78 in)  
Depth: 95.9 mm (3.70 in)

- Environmental Specifications**

Ambient Temperature Range: Operating: 0 to +70 degrees Celsius \*  
Storage: -40 to +85 degrees Celsius  
\*Temperature of inlet cooling air.

Relative Humidity: Operating: 0 to 80%, non-condensing  
Storage: 0 to 95%, non-condensing

Altitude: Operation to 10,000 ft.

Cooling: Conventional convection cooling

- Cooling Requirements**

Conventional air cooling; 200 LPFM (typical mezzanine environment).

### ORDERING INFORMATION

Specify the basic product model number PC104P-16AI64.

**General Standards Corp.**  
8302A Whitesburg Drive  
Huntsville, AL 35802

---

**General Standards Corporation**

8302A Whitesburg Drive · Huntsville, AL 35802  
Phone: (256) 880-8787 or (800) 653-9970

FAX: (256) 880-0700

# **General Standards Corporation**

## ***High Performance Bus Interface Solutions***

General Standards Corporation assumes no responsibility for the use of any circuits in this product. No circuit patent licenses are implied. Information included herein supersedes previously published specifications on this product and is subject to change without notice.

---

**General Standards Corporation**

8302A Whitesburg Drive · Huntsville, AL 35802

Phone: (256) 880-8787 or (800) 653-9970

FAX: (256) 880 0700

# General Standards Corporation

## High Performance Bus Interface Solutions

### SYSTEM I/O CONNECTIONS

Table 1. System Connector Pin Functions

P2 ROW-A			P2 ROW-B		
PIN	SIGNAL		PIN	SIGNAL	
	S.E. MODE	DIFF MODE		S.E. MODE	DIFF MODE
1	INP00	INP00 HI	1	INP32	INP16 HI
2	INP01	INP00 LO	2	INP33	INP16 LO
3	INP02	INP01 HI	3	INP34	INP17 HI
4	INP03	INP01 LO	4	INP35	INP17 LO
5	INP04	INP02 HI	5	INP36	INP18 HI
6	INP05	INP02 LO	6	INP37	INP18 LO
7	INP06	INP03 HI	7	INP38	INP19 HI
8	INP07	INP03 LO	8	INP39	INP19 LO
9	INP08	INP04 HI	9	INP40	INP20 HI
10	INP09	INP04 LO	10	INP41	INP20 LO
11	INP10	INP05 HI	11	INP42	INP21 HI
12	INP11	INP05 LO	12	INP43	INP21 LO
13	INP12	INP06 HI	13	INP44	INP22 HI
14	INP13	INP06 LO	14	INP45	INP22 LO
15	INP14	INP07 HI	15	INP46	INP23 HI
16	INP15	INP07 LO	16	INP47	INP23 LO
17	AGND	AGND	17	AGND	AGND
18	AGND	AGND	18	VTEST	VTEST
19	INP16	INP08 HI	19	INP48	INP24 HI
20	INP17	INP08 LO	20	INP49	INP24 LO
21	INP18	INP09 HI	21	INP50	INP25 HI
22	INP19	INP09 LO	22	INP51	INP25 LO
23	INP20	INP10 HI	23	INP52	INP26 HI
24	INP21	INP10 LO	24	INP53	INP26 LO
25	INP22	INP11 HI	25	INP54	INP27 HI
26	INP23	INP11 LO	26	INP55	INP27 LO
27	INP24	INP12 HI	27	INP56	INP28 HI
28	INP25	INP12 LO	28	INP57	INP28 LO
29	INP26	INP13 HI	29	INP58	INP29 HI
30	INP27	INP13 LO	30	INP59	INP29 LO
31	INP28	INP14 HI	31	INP60	INP30 HI
32	INP29	INP14 LO	32	INP61	INP30 LO
33	INP30	INP15 HI	33	INP62/ SYNC HI*	INP31 HI/ SYNC HI*
34	INP31	INP15 LO	34	INP63/ SYNC LO*	INP31 LO/ SYNC LO*

\* Software-selected.

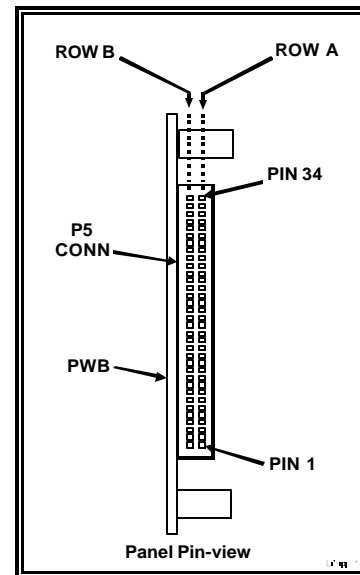

Figure 2. System Input Connector

#### System Mating Connector:

Standard 68-pin 0.050" D-Subminiature male connector:

AMP# 1-750913-7 or equivalent.