



Series 604A Differential Pressure Transmitter

Specifications - Installation and Operating Instructions



Patent No. 301,018

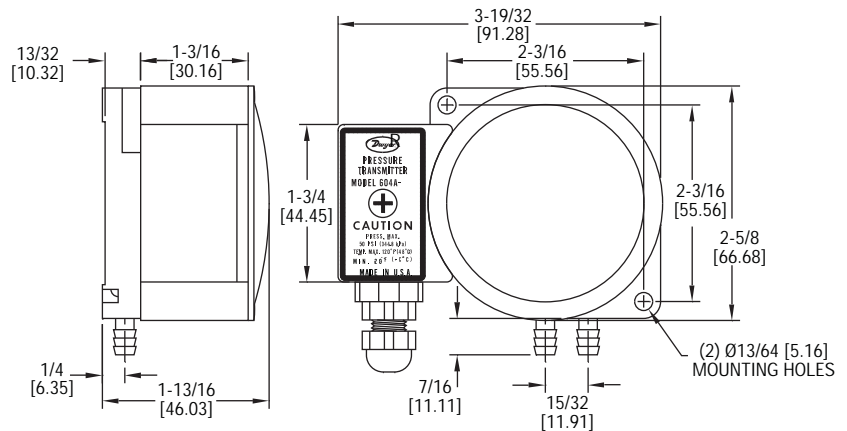

The Dwyer Series 604A Differential Pressure Transmitter converts air or compatible gas pressure into a standard 4-20 mA output signal for pressure ranges from 0-0.4" up to 0-120" w.c. (0-2.54 mm up to 0-304.9 mm w.c.). Each of these models overlap in range so that any range within these limits can be achieved by adjustment of the span and zero controls. Versatile circuit design enables use in 2, 3 or 4-wire current loops.

Positive, negative or differential pressures can be measured within an accuracy of $\pm 2\%$ of span. The Series 604A uses an isolated piezoresistive pressure sensor to produce a resistance change across a wheatstone bridge. The signal is conditioned and converted into a 4-20 mA output signal.

For applications requiring direct pressure or percent of full span readings, the optional A-701 digital readout makes an ideal companion device. It provides a bright .6" (15.3 mm) high, 3-1/2 digit, LED display while also supplying power to the Series 604A Transmitter.

Model	RANGES IN INCHES OF WATER		
	As Stocked	Min. Range	Max. Range
604A-0	0-0.5 (0-12.7 mm)	0-0.4 (0-10.1 mm)	0-1.0 (0-25.4 mm)
604A-1	0-2.0 (0-50.8 mm)	0-0.5 (0-12.7 mm)	0-4.0 (0-101.6 mm)
604A-2	0-10 (0-254 mm)	0-2.0 (0-50.8 mm)	0-20 (0-50.8 cm)
604A-3	0-50 (0-127 cm)	0-15 (0-381 mm)	0-120 (0-305 cm)

SPECIFICATIONS

Service: Air and non-combustible, compatible gases.

Wetted Materials: Consult factory.

Accuracy: $\pm 2\%$ of full span output (Includes linearity, hysteresis and repeatability).

Stability: $\pm 1\%$ F.S./yr.

Temperature Limits: 0 to 140°F (-17.8 to 60°C).

Compensated Temperature Limits: 20 to 120°F (-6.67 to 48.9°C).

Pressure Limits: 2 psig for models 604A-0, 604A-1; 11 psig for models 604A-2, 604A-3.

Thermal Effect: $\pm 0.025\%$ F.S./°F (0.045% F.S./°C).

Power Requirements: 10-35 VDC (2-wire*).

Output Signal: 4 to 20 mA.

Zero and Span Adjustments: Internally accessible Potentiometers.

Loop Resistance: DC; 0-1250 ohms maximum.

Current Consumption: DC; 38 mA maximum.

Electrical Connections: Terminal block.

Process Connections: Barbed, for 3/16" (4.76 mm) I.D. tubing.

Mounting Orientation: Diaphragm in vertical position. Consult factory for other position orientations.

Weight: 5.6 oz (159 g).

Agency Approvals: CE.

INSTALLATION

LOCATION: Select a location where temperature of the unit will be between 20°F and 120°F (7°C and 49°C). Distance from the receiver is limited only by total loop resistance. See "Electrical Connections." The tubing feeding pressure to the instrument can be run practically any length required, but long lengths will slightly increase response time. Avoid surfaces with excessive vibration.

POSITION: The Model 604A-0 must be mounted and operated only in a vertical position due to its sensitivity to gravitational forces. Higher range models will perform properly at other angles, but they must be spanned and zeroed in the position in which they will be used. The minimum and maximum ranges possible may shift depending upon degree of tilt.

PRESSURE CONNECTIONS: Two barbed connectors are provided for use with 3/16" I.D. vinyl or rubber tubing. Attach tubing from positive pressure source to HI port. Leave LO port vented. For negative (vacuum) pressure, connect to LO port and leave HI port vented. For differential pressures, connect the higher to HI port and lower to LO port.

MOUNTING: Attach the Series 604A Transmitter to a vertical surface using the #10 x 1" pan head sheet metal screws provided. Mounting holes are located in upper left and lower right corners of case.

ELECTRICAL CONNECTIONS

CAUTION: DO NOT EXCEED SPECIFIED SUPPLY VOLTAGE RATINGS. PERMANENT DAMAGE NOT COVERED BY WARRANTY WILL RESULT. THIS UNIT IS NOT DESIGNED FOR 120 VAC or 240 VAC LINE OPERATION.

Electrical connections to the Series 604A Transmitter are made inside the enclosure on the left side of the unit. Remove the cover, feed stripped and tinned leads through the bottom and connect to terminal block screws marked 1,2,3 or 4. Refer to Figure B for locations of terminal block, span and zero adjust potentiometers.

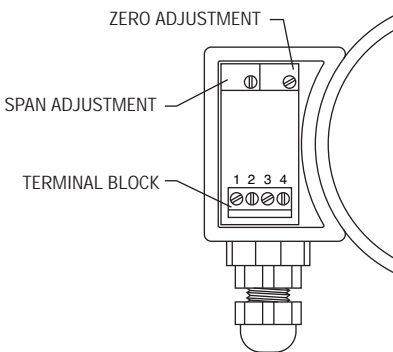

Fig. B

Wire Length - The maximum length of wire connecting transmitter and receiver is a function of wire size and receiver resistance. Wiring should not contribute more than 10% of receiver resistance to total loop resistance. For extremely long runs (over 1000 ft. [305 m]), choose receivers with higher resistances to minimize size and cost of connecting leads. Where wiring length is under 100 ft. (30.48 m), lead wire as small as 22 AWG can be used.

2-Wire Operation - An external power supply delivering 13-35 VDC with minimum current capability of 40 mA DC (per transmitter) must be used to power the control loop. See Fig. C for connection of the power supply, transmitter and receiver. Note the jumper between terminals 3 and 4. The range of appropriate receiver load resistance (R_L) for the DC power supply voltage available is expressed by the formula and graph in Fig. F. Shielded two wire cable is recommended for control loop wiring. If grounding is required use negative side of control loop after receiver. In Fig. C below, if power supply lead to terminal 1 is positive, ground should be connected to wiring at right of receiver. Otherwise, in 2 wire operation it is not necessary to observe polarity of control loop connections.

2-WIRE CONNECTION

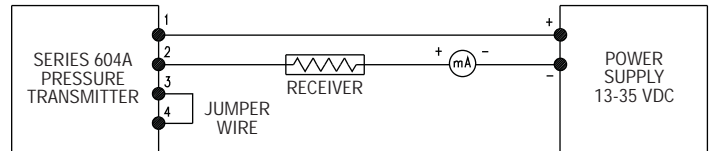

Fig. C

3-Wire Operation - An external power supply delivering 13-35 VDC with minimum current capability of 40 mA DC (per transmitter) is required. See Fig. D for connection of power supply, transmitter and receiver. The range of appropriate receiver load resistance (R_L) for the DC power supply available is expressed by the formula and graph in Fig. F. Shielded cable is recommended for control loop wiring. Do not employ a separate ground in 3 wire operation. Unit will not function properly and/or damage could result. Control loop polarity must be observed in the following respect. Although power supply terminals 1 and 2 are not polarized, the receiver must be connected between terminal 4 of transmitter and negative side of power supply.

3-WIRE CONNECTION

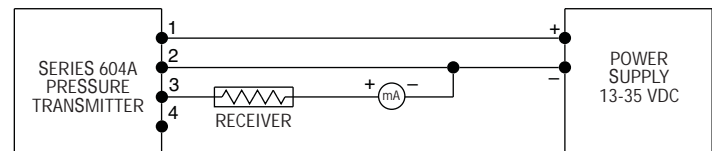
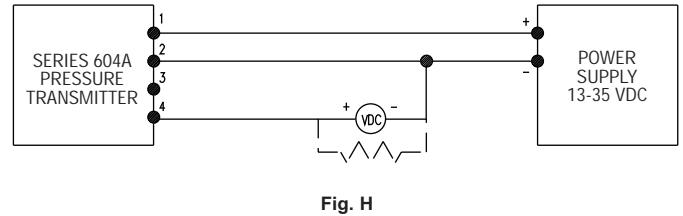

Fig. D

4-Wire Operation - An external power supply delivering 13-35 VDC with minimum current capability of 40 mA DC (per transmitter) or 18-26 VAC with minimum current capability of 80 mA AC (per transmitter) is required. See Fig. E for connection of power supply, transmitter and receiver. The range of appropriate load resistance (R_L) for the DC or AC power supply available is expressed by the formulas and graphs in Figs. F and G. Shielded cable is recommended for control loop wiring. Do not employ a separate ground in 4 wire operation. Unit will not function properly and /or damage could result. Control loop polarity must be observed, terminal 3 is negative and terminal 4 is positive. Power supply terminals 1 and 2 are not polarized.

Voltage Output - Series 604A Differential Pressure Transmitters can be easily adapted for receivers requiring 1-5 VDC or 2-10 VDC input. Insert a 249 OHM, $\frac{1}{2}$ watt (1-5 VDC) or 499 ohm (2-10 VDC) resistor in series with the current loop but in parallel with the receiver input. Locate this resistor as close as possible to the input. Because resistor accuracy directly influences output signal accuracy, we recommend use of a precision $\pm 0.1\%$ tolerance resistor to minimize this effect. See Figs. H and J.

3-WIRE CONNECTION (1-5/2-10 VDC OUTPUT)



4-WIRE CONNECTION (1-5/2-10 VDC OUTPUT)

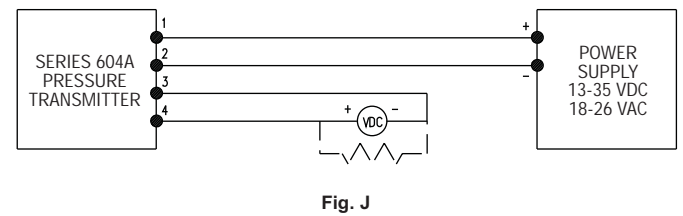

4 WIRE CONNECTION

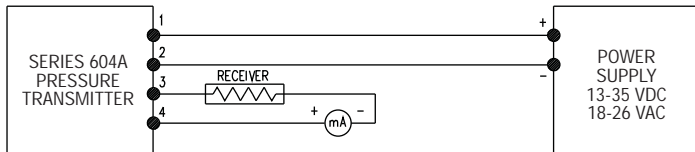

Fig. E

Fig. H

Fig. J

POWER SUPPLY VOLTAGE-VDC (2, 3, OR 4 wire)

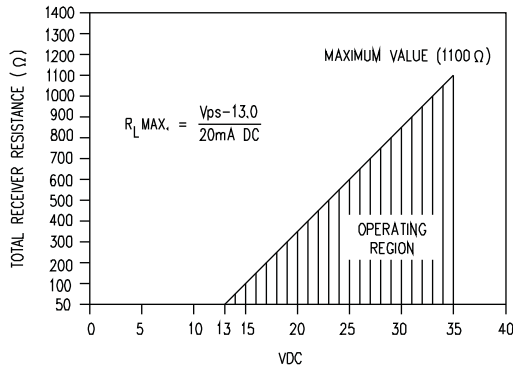

Fig. F

POWER SUPPLY VOLTAGE-VAC (4 wire)

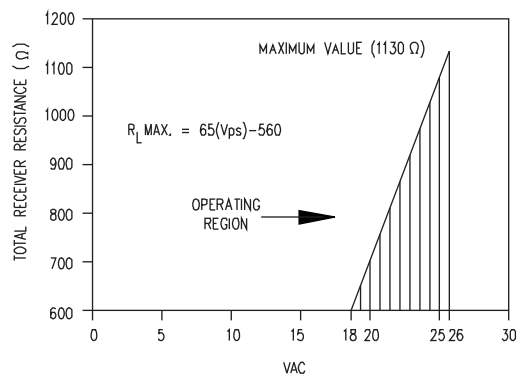

Fig. G

PRESSURE RANGING

Each standard Series 604A Transmitter is factory calibrated to a specific stock range as shown in the Model Number Chart. If unit was specially calibrated it will be marked accordingly. To check calibration or re-calibrate to a different range (within limits described in chart), follow the procedure below. For clarification, range is defined as that pressure which applied to the transmitter will produce 20 mA DC of loop current. Zero pressure will produce 4 mA DC.

1. With transmitter connected to its companion receiver and power supply, an accurate milliammeter ranged to approximately 30 mA should be inserted in series with the current loop. A controllable pressure source should be connected to one leg of a tee with remaining legs run to the high pressure port of the transmitter and an accurate reference gage or manometer. Low pressure port must be vented to atmosphere. The transmitter must be calibrated in the same position in which it will be used; vertical is recommended.
2. Apply electrical power to the system and check for proper operation. Slowly apply pressure and observe whether loop current increases above the 4 mA zero pressure value.
3. Remove enclosure cover. Apply the full range pressure required and adjust the SPAN control on left for a reading of 20 mA in the current loop.
4. Relieve pressure and adjust the ZERO control on right for a reading of 4 mA in the current loop.
5. ZERO and SPAN controls are slightly interactive so steps 3 and 4 should be repeated until outputs are consistently 4 and 20 mA, respectively.
6. Remove the milliammeter from the current loop, replace cover, make connections to system pressure sources and place unit in service.

MULTIPLE RECEIVER INSTALLATION

An advantage of the standard 4-20 mA DC output signal used in Series 604A Transmitters is the compatibility with a wide range of receivers. Devices such as the A-701 Digital Readout, A-702 Digital Readout with alarms, an analog panel meter, a chart recorder and other process control equipment can be operated simultaneously. It is only necessary that all devices be designed for a standard 4-20 mA input, the proper polarity of input connections be observed and the combined receiver resistances must not exceed the maximum for the current loop. If any receiver indicates a negative or downscale reading, the signal input leads are reversed.

MAINTENANCE

After final installation of the Series 604A Differential Pressure Transmitter, no routine maintenance is necessary. A periodic check of calibration is recommended following the procedure under PRESSURE RANGING. Except for this, these transmitters are not field serviceable and should be returned, freight prepaid, to the factory if repair is needed. Be sure to include a clear description of the problem plus any application information available.