

Sym.	Date	Revision	Signed	checked

Finish Marks

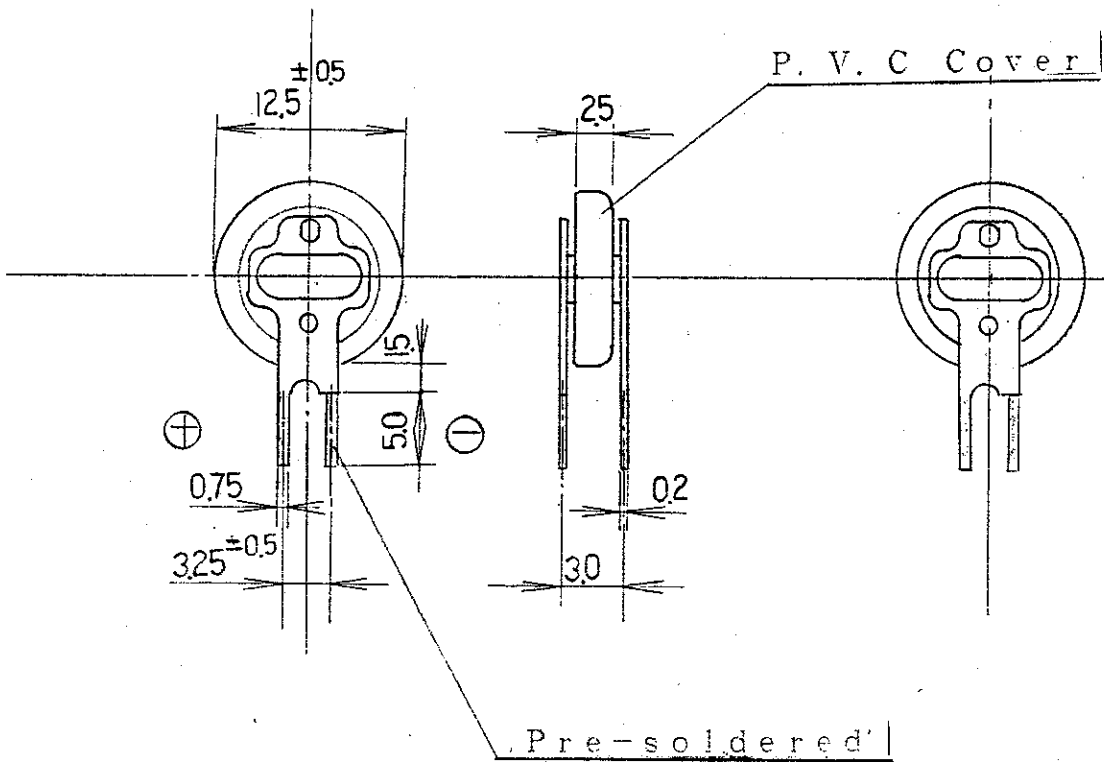

Laser beam weld both sides

Unit: mm

指示ナキ角ハ糸面取りノ事 (ISO)
IF NOT INDICATED MUST BE LESS THAN 0.2C

Sym.	Item or Code No.	Material & Size	qt.	Process	Remark
E	J	Spare Parts			
	E				

Scale	2	Designed	A.H.	Drawn	Traced	Checked	g.o.	Approved	K.M.	Jap. Name			
	1									Eng. Name	BR1225-1VC		
										M. No.	A. No.	F. No.	