

Brackets,
etc.

Proximity Sensor Accessories

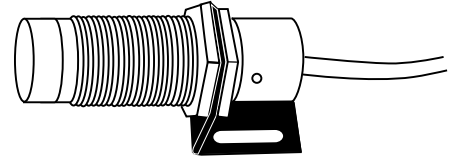

Proximity Sensors

12-47mm TUBULAR MOUNTING BRACKETS

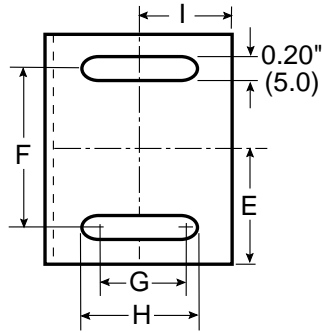

12-30mm Base

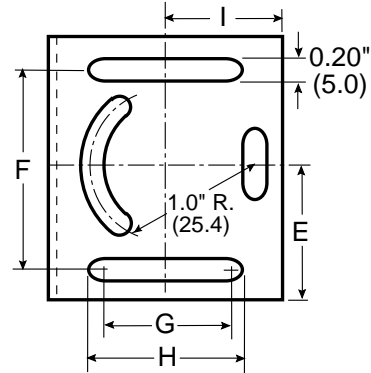

47mm Base

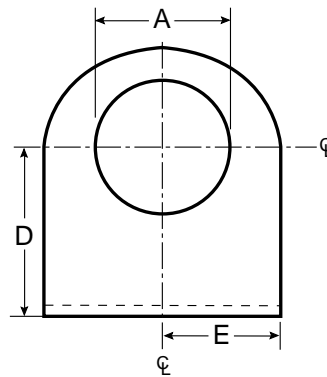
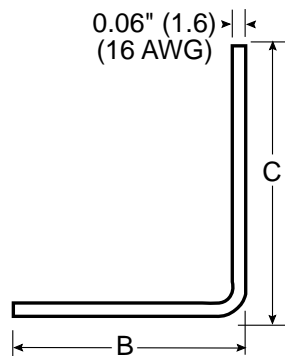

12-47mm Side and Front

Model No.	Sensor Diameter	Hole Diameter	Depth	Height	Height to Center	Width to Center	Slot Centers	Drill Centers	Slot Length	Depth Center	Material
		A	B	C	D	E	F	G	H	I	
EE972-01803	8mm	0.38" (9.6)	1.00" (25.4)	1.25" (31.8)	0.75" (19.1)	0.50" (12.7)	0.51" (13.0)	0.36" (9.1)	0.56" (14.2)	0.50" (12.7)	C. F. Steel
EE972-01804	12mm	0.50" (12.7)	1.00" (25.4)	1.25" (31.8)	0.75" (19.1)	0.50" (12.7)	0.51" (13.0)	0.36" (9.1)	0.56" (14.2)	0.50" (12.7)	C. F. Steel
EE972-01835	18mm	0.76" (19.5)	1.00" (25.4)	1.51" (38.2)	0.88" (22.3)	0.63" (15.8)	0.80" (20.3)	0.46" (11.6)	0.66" (16.7)	0.56" (14.2)	C. F. Steel
EE972-01807	30mm	1.25" (31.8)	1.50" (38.1)	1.92" (48.6)	1.09" (27.6)	0.83" (20.9)	1.16" (29.3)	0.80" (20.3)	1.00" (25.4)	0.75" (19.0)	C. F. Steel
EE972-02001	47mm	1.86" (47.2)	1.50" (38.1)	2.84" (72.0)	1.59" (40.3)	1.25" (31.8)	2.00" (50.8)	0.80" (20.3)	1.00" (25.4)	0.75" (19.0)	C. F. Steel

25mm ADJUSTABLE EXTENDED RANGE SENSOR MOUNTING BRACKET KIT

Part No. EE972-01860
 Allows 25mm Proximity Sensors to be adjusted similarly to a standard tubular sensor. Kit includes (4) #10-32 socket head cap screws and (2) hex jam nuts.

Part No. EE972-01861
 Bracket only.

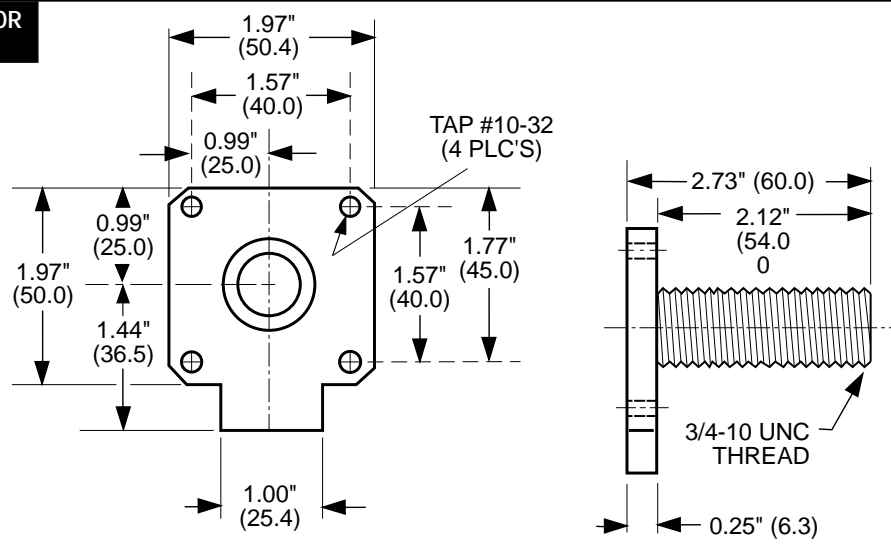

40mm FLATPAK BRACKET

Part No. EE972-01859

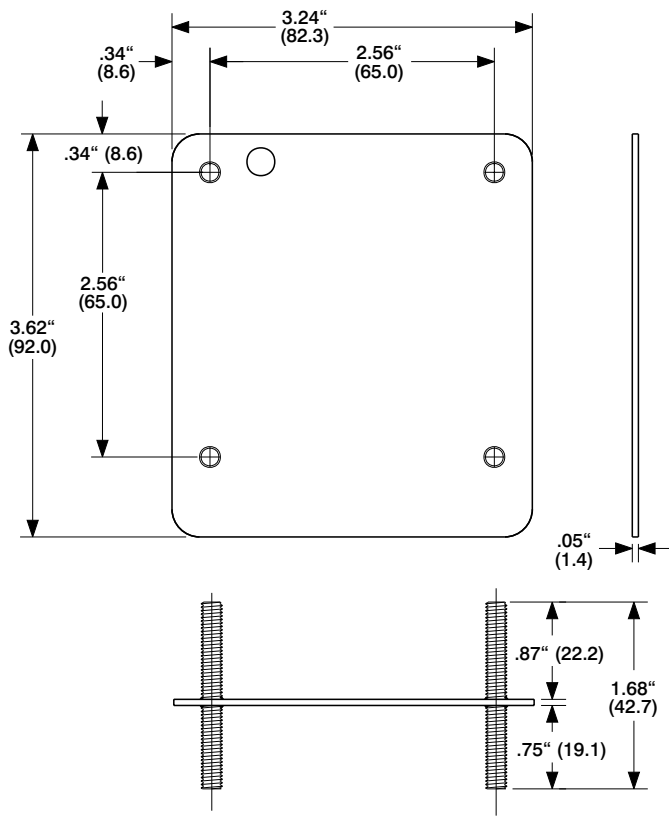

12mm TUBULAR BRACKET

Part No. EE972-01834

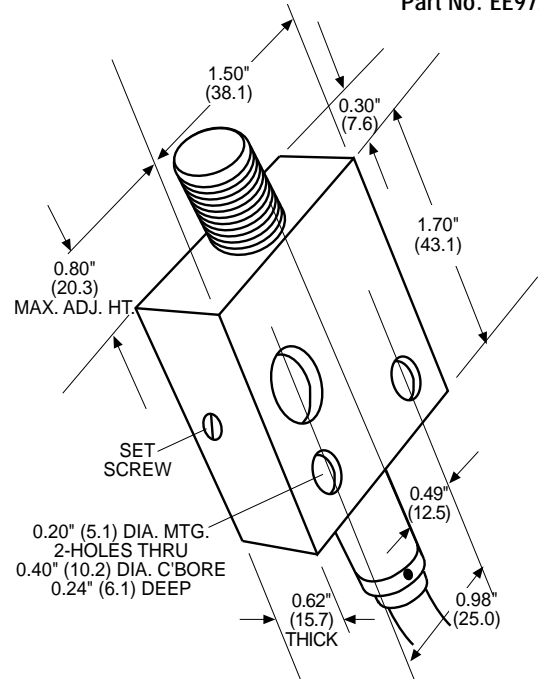

Continued on next page. →



2013 West Meeting Street • Lancaster, SC 29720
 1-803-286-8491 • FAX: 1-800-678-6263
www.namcocontrols.com

For technical assistance, call 1-800-NAMTECH

Brackets, etc.

Proximity Sensor Accessories

CONDUIT ADAPTERS

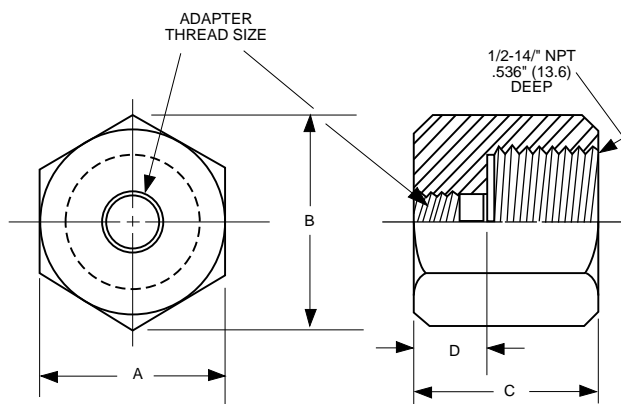

Adapter Thread Size (mm)	HEX SIZE				Model No.
	Flats	Corners	Length	Depth	
	A	B	C	D	
8	1.00" (25.4)	1.15" (29.2)	1.00" (25.4)	0.25" (6.3)	EE014-20009
12	1.00" (25.4)	1.15" (29.2)	1.50" (38.1)	0.25" (6.3)	EE014-20010
18	1.00" (25.4)	1.15" (29.2)	2.00" (50.8)	0.25" (6.3)	EE014-20011
30	1.50" (38.1)	1.73" (43.9)	2.25" (57.1)	0.38" (9.6)	EE014-20012
47	2.00" (50.8)	2.31" (58.7)	2.50" (63.5)	0.38" (9.6)	EE014-20013

Material: Aluminum 2024
Stainless Steel version available on special order.
Consult factory.

MOUNTING NUTS

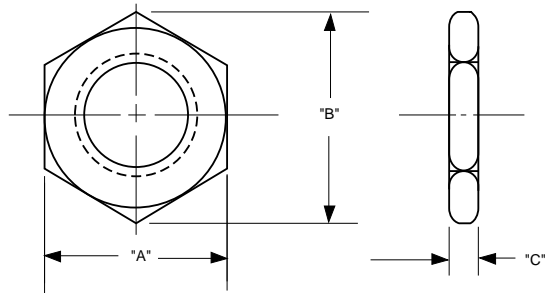

I.D.	Mounting Nuts					Lock Washer Black, Serrated
	Dimensions			Model No.		
	A	B	C	Metal	Plastic	
3/4-20	1.06" (26.9)	1.22" (30.9)	0.16" (4.1)	EE154-80001*	-	-
8mm	0.51" (13.0)	0.58" (14.7)	0.16" (4.1)	EE013-80011	EE013-80000	-
12mm	0.67" (17.0)	0.77" (19.5)	0.22" (5.6)	EE013-80003	EE013-81003	EE100-00139
18mm	0.94" (23.8)	1.06" (26.9)	0.16" (4.1)	EE013-80002*	EE013-81002	EE100-00137
30mm	1.44" (36.6)	1.66" (42.2)	0.19" (4.8)	EE013-80001*	EE013-81001	EE100-00138
47mm	2.00" (50.8)	2.20" (55.9)	0.20" (5.1)	EE013-80004	-	-

*Quantity one (1) per package; all others are shipped two (2) per package.

CYLINDRICATOR® SENSOR SPACER KITS

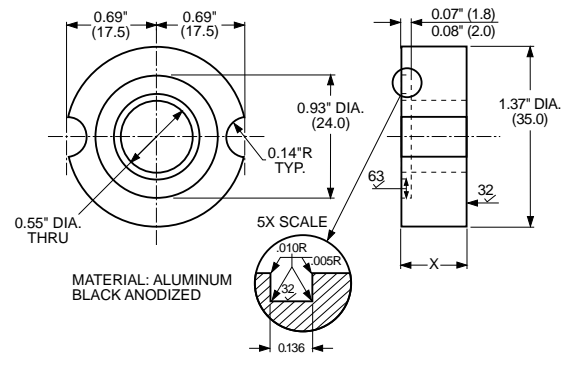

Kits include two mounting bolts and O-Ring. Replacement O-Ring is EE972-19306 (Equivalent to Parker # 2-116V709-90). Specify spacer height.

NOTE: Please consult factory before using spacer kits with LPR Cylindricator® sensors.

Dimension "X"	Model No.
0.19"	EE972-01827
0.25"	EE972-01822
0.31"	EE972-01829
0.38"	EE972-01831
0.50"	EE972-01820

TEFLON® CAPS

Repel weld slag; increase sensor life.

- Part No. EE505-60002**
For use with any 18mm Shielded Sensor
- Part No. EE505-60004**
For use with any 18mm Unshielded Sensor

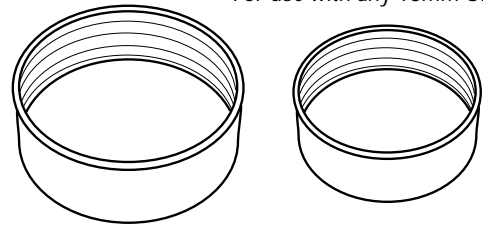

- Part No. EE505-60003**
For use with any 30mm Shielded Sensor
- Part No. EE505-60005**
For use with any 30mm Unshielded Sensor

WELD-SPLATTER RESISTANT COVERS

Part No. EE505-60001
For use with EE500-1 Rotatable Rectangular Sensors

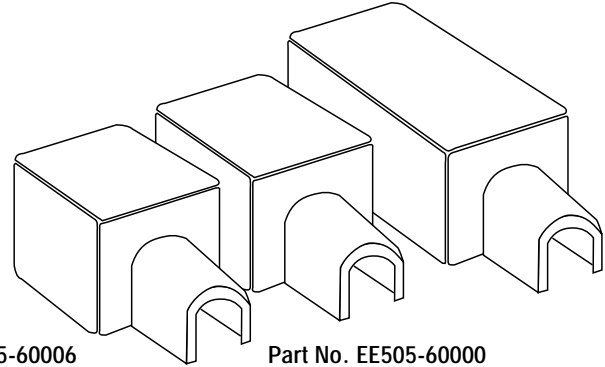

- Part No. EE505-60006**
For use with EE500-9 HammerHead Sensors
- Part No. EE505-60000**
For use with EE500-8 25mm Extended Range Sensors



2013 West Meeting Street • Lancaster, SC 29720
1-803-286-8491 • FAX: 1-800-678-6263
www.namcocontrols.com

For technical assistance, call 1-800-NAMTECH