

Filter Fan Packages



Application

Permits densely filtered ambient air to pressurize enclosure so that ambient air cannot be drawn in through poorly sealed doors, panels and wireways. Positive airflow provides a simple and effective way to protect enclosed electronics from heat and condensation. Ideal for clean environments.

Construction

- Simple, snap-in mounting
- Slim fan grille protrudes only .25 in. or less from enclosure mount
- Fan is completely installed inside plastic housing
- Housings are made of heat resistant, self-extinguishing ABS; color RAL 7042 gray (grille only)
- Air filter is accessible for cleaning or replacement from outside the enclosure by simply removing the grille cover
- Easy to install. Mounting hardware, full-size mounting template, drawings and installation instructions furnished.
- Filter Fan Package includes fan with grille, filter and filter sealing gasket. Exhaust Grille Kits are offered for each Filter Fan Package and must be ordered separately. Filter sealing gaskets are supplied with both Filter Fan Package and Exhaust Grille Kit to achieve an IP54 rating.

Industry Standards

UL Component Recognized, UL File Number SF165154
CSA Certified (fan only)
CE

Installation

Fan Package should be mounted near bottom of enclosure with the exhaust near the top of the opposite side. This will ensure complete airflow distribution through the entire enclosure.

Added Protection

With the supplied filter sealing gasket installed on both the filter fan package and the exhaust grille kit, an IP54 rating can be maintained according to DIN 40050. This rating is defined as protecting internal electronics from dust, foreign bodies and splashing water.

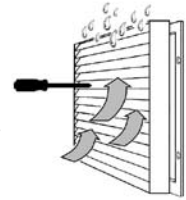

Replacement Filter Sealing Gasket and Filters

Filter Sealing Gasket Catalog Number	Replacement Filter	To Fit Fan Packages and Exhaust Grille Kits
G050000	10100060	SF0516002 SF0526002 SG0500002
G090000	10100061	SF0916002 SF0926002 SG0900002
G100000	10100062	SF1016002 SF1026002 SG1000002
G130000	10100063	SF1316002 SF1326002 SG1300002

Filtered Cooling

Filter Fan Packages are appropriate for applications in which:

- The electronic controls can operate at a temperature differential slightly above ambient temperature
- Humidity is not a factor
- The quality of filtered ambient air is acceptable to be drawn into the enclosure for cooling

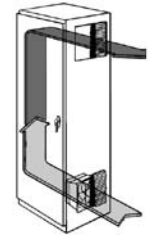

Series SF-05 Filter Fan Package

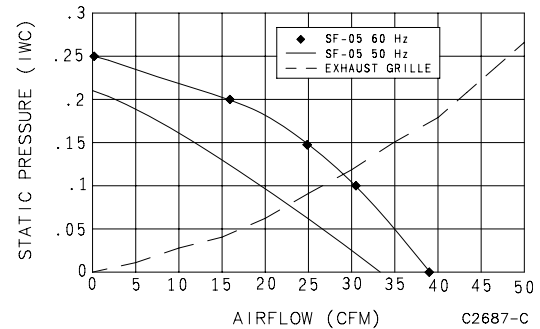
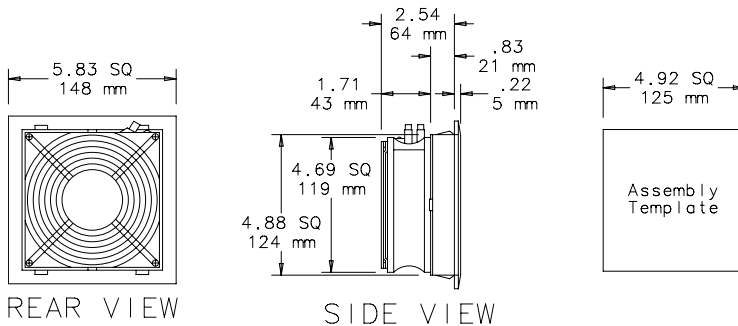

Fans, Blowers,
Louvers and Vents