

# Type 500R 85 °C High Ripple Current, Inverter Grade, Aluminum

## New Higher Ripple Current than Type 500C Screw Terminal Type



The Type 500R is a higher ripple-current version of CDE's long-life Type 500C specifically designed to provide the ripple current capability and long life required for high reliability inverter applications. Like the 500C, the 500R has an endurance rating of 5,000 hours at +85 °C with the rated ripple current applied, and it is offered in the 350 V to 500 V ratings appropriate for use as dc-link bus capacitors in inverter applications.

### Highlights

- Large can sizes
- Screw terminals, english and metric
- 5000 hour rated ripple current life
- Higher ripple current than 500C
- 350 to 500 Vdc ratings
- RoHS compliant

### Specifications

Temperature Range	-40 °C to +85 °C																																																																		
Rated Voltage Range	350 Vdc to 500 Vdc																																																																		
Capacitance Range	1,100 uF to 18,000 uF																																																																		
Capacitance Tolerance	±20%																																																																		
Leakage Current	≤3 √CV μA, 5 mA max, 5 minutes																																																																		
Ripple Current Multipliers	<p>Ambient Temperature</p> <table border="1"> <thead> <tr> <th>45 °C</th> <th>55 °C</th> <th>65 °C</th> <th>75 °C</th> <th>85 °C</th> </tr> </thead> <tbody> <tr> <td>2.00</td> <td>1.82</td> <td>1.59</td> <td>1.33</td> <td>1.00</td> </tr> </tbody> </table> <p>Frequency</p> <table border="1"> <thead> <tr> <th></th> <th>50 Hz</th> <th>60 Hz</th> <th>120 Hz</th> <th>360 Hz</th> <th>1 kHz</th> <th>5 kHz</th> <th>10 kHz &amp; up</th> </tr> </thead> <tbody> <tr> <td colspan="8" style="text-align: center;"><b>2 &amp; 2½" diameters</b></td> </tr> <tr> <td>350 V</td> <td>0.78</td> <td>0.83</td> <td>1.00</td> <td>1.20</td> <td>1.29</td> <td>1.34</td> <td>1.35</td> </tr> <tr> <td>400–500 V</td> <td>0.77</td> <td>0.82</td> <td>1.00</td> <td>1.22</td> <td>1.33</td> <td>1.39</td> <td>1.40</td> </tr> <tr> <td colspan="8" style="text-align: center;"><b>3 &amp; 3½" diameters</b></td> </tr> <tr> <td>350 V</td> <td>0.84</td> <td>0.88</td> <td>1.00</td> <td>1.12</td> <td>1.17</td> <td>1.20</td> <td>1.20</td> </tr> <tr> <td>400–500 V</td> <td>0.79</td> <td>0.84</td> <td>1.00</td> <td>1.18</td> <td>1.26</td> <td>1.31</td> <td>1.32</td> </tr> </tbody> </table>	45 °C	55 °C	65 °C	75 °C	85 °C	2.00	1.82	1.59	1.33	1.00		50 Hz	60 Hz	120 Hz	360 Hz	1 kHz	5 kHz	10 kHz & up	<b>2 &amp; 2½" diameters</b>								350 V	0.78	0.83	1.00	1.20	1.29	1.34	1.35	400–500 V	0.77	0.82	1.00	1.22	1.33	1.39	1.40	<b>3 &amp; 3½" diameters</b>								350 V	0.84	0.88	1.00	1.12	1.17	1.20	1.20	400–500 V	0.79	0.84	1.00	1.18	1.26	1.31	1.32
45 °C	55 °C	65 °C	75 °C	85 °C																																																															
2.00	1.82	1.59	1.33	1.00																																																															
	50 Hz	60 Hz	120 Hz	360 Hz	1 kHz	5 kHz	10 kHz & up																																																												
<b>2 &amp; 2½" diameters</b>																																																																			
350 V	0.78	0.83	1.00	1.20	1.29	1.34	1.35																																																												
400–500 V	0.77	0.82	1.00	1.22	1.33	1.39	1.40																																																												
<b>3 &amp; 3½" diameters</b>																																																																			
350 V	0.84	0.88	1.00	1.12	1.17	1.20	1.20																																																												
400–500 V	0.79	0.84	1.00	1.18	1.26	1.31	1.32																																																												
Low Temperature Characteristics	Impedance ratio: $Z_{-20°C} / Z_{+25°C}$ ≤ 3 (350–500 Vdc)																																																																		
Endurance Life Test	5000 h at full load at 85 °C Δ Capacitance ±20% ESR 200% of limit DCL 100% of limit																																																																		
Shelf Life Test	500 h at 85 °C Capacitance 100% of limit ESR 100% of limit DCL 100% of limit																																																																		
Vibration	10 to 55 Hz, 0.06" and 10 g max, 1.5 h each of 2 axes																																																																		
RoHS Compliant																																																																			

# Type 500R 85 °C High Ripple Current, Inverter Grade, Aluminum

New Higher Ripple Current than Type 500C Screw Terminal Type

## Part Numbering System

<b>500R</b>	<b>103</b>	<b>M</b>	<b>350</b>	<b>DN</b>	<b>2</b>	<b>E</b>	<b>S</b>
<b>Type</b>	<b>Capacitance</b>	<b>Tolerance</b>	<b>Voltage</b>	<b>Case Code</b>	<b>Insulation</b>	<b>Terminal</b>	<b>Can Style</b>
	472 = 4700 $\mu$ F 103 = 10,000 $\mu$ F	M = $\pm$ 20% U = -10%+75% T = 10%+50%	350 = 350 Vdc 500 = 500 Vdc		0= None 1= Polyester 2= PVC	A = Low Post B = High Post D = High Current, Low Post E = High Current, High Post F or M = M5 Post G = M6 Low Post H = M6 High Post	Blank= Standard Can S= Stud Bottom P= Stud with Thermal Pad

## Outline Drawing

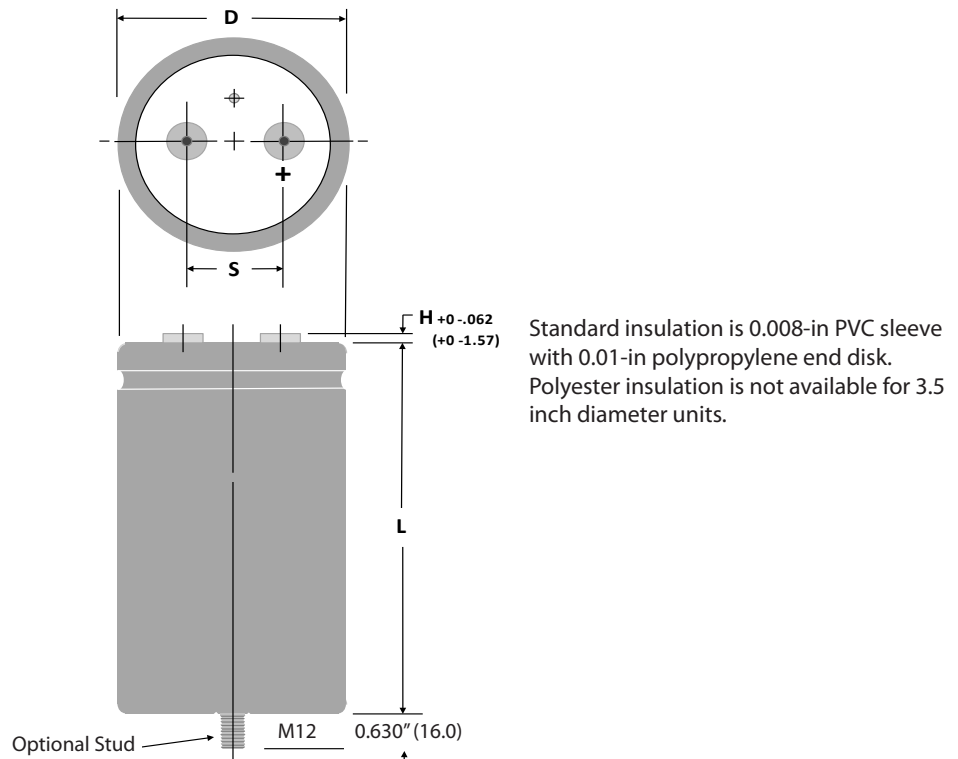

NOTE: With the stud-mount feature, a thermally-conductive disk can be inserted in the bottom flush with the outer insulating sleeve. This reduces the thermal resistance through the can bottom by 0.3 °C/W. Can Style P.

## Terminal Dimensions

Terminal Style	For Case		Post Diameter		H max		Thread	min Full Thread		Torque	
	Diameters	Code	in	mm	in	mm		in	mm	in-lb	N-m
Low Post	2 to 3	A	0.314	8.0	0.094	2.4	10-32	0.218	5.5	25	2.82
High Post	2 to 3	B	0.314	8.0	0.281	7.1	10-32	0.375	9.5	25	2.82
High Current, Low	2½ to 3½	D	0.684	17.4	0.125	3.2	¼-28	0.344	8.7	50	5.65
High Current, High	2½ to 3½	E	0.684	17.4	0.281	7.1	¼-28	0.469	11.9	60	6.78
M5 Post, Small	1⅝ to 2	M	0.314	8.0	0.281	7.1	M5	0.375	9.5	25	2.82
M5 Post	2½ & 3	F	0.512	13.0	0.230	5.8	M5	0.344	8.7	25	2.82
M6 Low Post	2½ to 3½	G	0.684	17.4	0.125	3.2	M6	0.344	8.7	50	5.65
M6 High Post	2½ to 3½	H	0.684	17.4	0.281	7.1	M6	0.469	11.9	60	6.78

# Type 500R 85 °C High Ripple Current, Inverter Grade, Aluminum

## New Higher Ripple Current than Type 500C Screw Terminal Type

### Uninsulated Case Dimensions

For insulated case, add 0.024"(0.610 mm) to "D" and 0.030"(0.762 mm) to length.

Case Code	Diameter (D)		Length (L)		Terminals (S)		Typical Weight	
	±0.031 in	±0.78 mm	±0.062 in	±1.57 mm	±0.015 in	±0.38 mm	oz	g
<b>BC</b>	2.000	50.80	4.125	104.78	0.88	22.23	9.5	269
<b>BD</b>	2.000	50.80	4.625	117.48	0.88	22.23	10.3	292
<b>BE</b>	2.000	50.80	5.125	130.18	0.88	22.23	10.7	303
<b>BF</b>	2.000	50.80	5.625	142.88	0.88	22.23	13.0	369
<b>CH</b>	2.500	63.50	2.625	66.68	1.13	28.58	9.2	261
<b>CJ</b>	2.500	63.50	3.625	92.08	1.13	28.58	12.7	361
<b>CC</b>	2.500	63.50	4.125	104.78	1.13	28.58	15.0	425
<b>CD</b>	2.500	63.50	4.625	117.48	1.13	28.58	17.2	488
<b>CE</b>	2.500	63.50	5.125	130.18	1.13	28.58	19.3	547
<b>CF</b>	2.500	63.50	5.625	142.88	1.13	28.58	21.4	607
<b>DB</b>	3.000	76.20	3.125	79.38	1.25	31.75	16.7	473
<b>DJ</b>	3.000	76.20	3.625	92.08	1.25	31.75	20.0	567
<b>DC</b>	3.000	76.20	4.125	104.78	1.25	31.75	22.2	629
<b>DD</b>	3.000	76.20	4.625	117.48	1.25	31.75	25.5	723
<b>DE</b>	3.000	76.20	5.125	130.18	1.25	31.75	30.0	850
<b>DF</b>	3.000	76.20	5.625	142.88	1.25	31.75	31.9	904
<b>DP</b>	3.000	76.20	5.875	149.23	1.25	31.75	32.8	931
<b>DN</b>	3.000	76.20	7.625	193.68	1.25	31.75	39.5	1119
<b>DG</b>	3.000	76.20	8.625	219.08	1.25	31.75	43.3	1227
<b>FC</b>	3.500	88.90	4.125	104.78	1.25	31.75	30.0	850
<b>FD</b>	3.500	88.90	4.625	117.48	1.25	31.75	34.4	976
<b>FE</b>	3.500	88.90	5.125	130.18	1.25	31.75	40.5	1148
<b>FF</b>	3.500	88.90	5.625	142.88	1.25	31.75	43.1	1221
<b>FP</b>	3.500	88.90	5.875	149.23	1.25	31.75	44.3	1257
<b>FN</b>	3.500	88.90	7.625	193.68	1.25	31.75	53.3	1512
<b>FG</b>	3.500	88.90	8.625	219.08	1.25	31.75	58.5	1658

# Type 500R 85 °C High Ripple Current, Inverter Grade, Aluminum

## New Higher Ripple Current than Type 500C Screw Terminal Type Ratings

Cap (µF)	Catalog Part Number	ESR Max. 25 °C		Ripple Amps. 85 °C		Nominal Size D x L (in)
		120 Hz (mΩ)	10kHz (mΩ)	120 Hz (A)	>3 kHz (A)	
<b>350 Vdc (400 Vdc Surge)</b>						
2200	500R222M350BC2B	47	37.6	8.0	11.3	2 X 4 1/8
2200	500R222M350BD2B	43	34.4	9.0	12.6	2 X 4 5/8
2700	500R272M350BE2B	38	30.4	10.0	14.0	2 X 5 1/8
2800	500R282M350CJ2E	36	28.8	10.0	14.0	2 1/2 X 3 5/8
3100	500R312M350BF2B	33	26.4	11.0	15.4	2 X 5 5/8
3300	500R332M350CC2E	30	24.0	12.0	16.8	2 1/2 X 4 1/8
3600	500R362M350CD2E	24	19.2	14.0	19.6	2 1/2 X 4 5/8
3900	500R392M350CE2E	23	18.4	15.0	21.0	2 1/2 X 5 1/8
3900	500R392M350DJ2E	23	18.4	14.0	19.6	3 X 3 5/8
4700	500R472M350CF2E	19	15.2	16.0	22.4	2 1/2 X 5 5/8
4700	500R472M350DC2E	19	15.2	16.0	22.4	3 X 4 1/8
5000	500R502M350CP2E	18	14.4	18.0	25.2	2 1/2 X 5 7/8
5600	500R562M350DD2E	16	12.8	18.0	25.2	3 X 4 5/8
6200	500R622M350DE2E	15	12.0	19.0	26.6	3 X 5 1/8
6800	500R682M350DF2E	14	11.2	21.0	29.4	3 X 5 5/8
6800	500R682M350FC2E	16	12.8	20.2	28.3	3 1/2 X 4 1/8
7000	500R702M350CN2E	13	10.4	23.0	32.2	2 1/2 X 7 5/8
7200	500R722M350DP2E	13	10.4	22.0	30.8	3 X 5 7/8
7700	500R772M350FD2E	14	11.2	21.6	30.2	3 1/2 X 4 5/8
8200	500R822M350CG2E	12	9.6	24.0	33.6	2 1/2 X 8 5/8
8200	500R822M350FE2E	12	9.6	24.0	33.6	3 1/2 X 5 1/8
10000	500R103M350DN2E	9	7.2	28.0	39.2	3 X 7 5/8
10000	500R103M350FF2E	10	8.0	27.7	38.8	3 1/2 X 5 5/8
10800	5051082M350FP2E	9	7.2	28.4	39.8	3 1/2 X 5 7/8
12000	500R123M350DG2E	8	6.4	32.5	45.5	3 X 8 5/8
15000	500R153M350FN2E	6	4.8	38.1	53.4	3 1/2 X 7 5/8
18000	500R183M350FG2E	6	4.8	44.6	62.5	3 1/2 X 8 5/8
<b>400 Vdc (450 Vdc Surge)</b>						
2,200	500R222M400BC2B	44.0	35.2	8.3	11.7	2 X 4 1/8
2,200	500R222M400BD2B	40.0	32.0	9.7	13.5	2 X 4 5/8
2,700	500R272M400BE2B	37.0	29.6	10.5	14.7	2 X 5 1/8
2,700	500R272M400CJ2E	37.0	29.6	10.1	14.2	2 1/2 X 3 5/8
3,000	500R302M400BF2B	35.0	28.0	11.0	15.4	2 X 5 5/8
3,300	500R332M400CC2E	31.0	24.8	11.8	16.5	2 1/2 X 4 1/8
3,600	500R362M400CD2E	27.0	21.6	13.1	18.3	2 1/2 X 4 5/8
3,900	500R392M400CE2E	25.0	20.0	13.8	19.3	2 1/2 X 5 1/8
3,900	500R392M400DJ2E	26.0	20.8	13.7	19.1	3 X 3 5/8
4,700	500R472M400CF2E	22.0	17.6	15.4	21.5	2 1/2 X 5 5/8
4,800	500R482M400DC2E	22.0	17.6	15.2	21.3	3 X 4 1/8
5,000	500R502M400CP2E	20.0	16.0	17.1	24.0	2 1/2 X 5 7/8
5,600	500R562M400DD2E	19.0	15.2	16.8	23.6	3 X 4 5/8
6,300	500R632M400DE2E	17.0	13.6	18.6	26.0	3 X 5 1/8

Cap (µF)	Catalog Part Number	ESR Max. 25 °C		Ripple Amps. 85 °C		Nominal Size D x L (in)
		120 Hz (mΩ)	10kHz (mΩ)	120 Hz (A)	>3 kHz (A)	
<b>400 Vdc (450 Vdc Surge)</b>						
6,700	500R672M400FC2E	16.0	12.8	20.0	28.1	3 1/2 X 4 1/8
6,800	500R682M400DF2E	16.0	12.8	19.9	27.9	3 X 5 5/8
6,900	500R692M400CN2E	15.0	12.0	21.2	29.7	2 1/2 X 7 5/8
7,200	500R722M400DP2E	15.0	12.0	20.7	29.0	3 X 5 7/8
7,300	500R732M400FD2E	14.0	11.2	21.6	30.2	3 1/2 X 4 5/8
8,200	500R822M400CG2E	13.0	10.4	24.1	33.7	2 1/2 X 8 5/8
8,200	500R822M400FE2E	13.0	10.4	24.0	33.6	3 1/2 X 5 1/8
9,200	500R922M400DN2E	12.0	9.6	24.4	34.2	3 X 7 5/8
10,000	500R103M400DG2E	10.0	8.0	27.6	38.6	3 X 8 5/8
10,000	500R103M400FF2E	10.0	8.0	27.3	38.2	3 1/2 X 5 5/8
11,000	5051102M400FP2E	10.0	8.0	28.3	39.7	3 1/2 X 5 7/8
13,000	500R133M400FN2E	8.0	6.4	32.9	46.0	3 1/2 X 7 5/8
15,000	500R153M400FG2E	7.0	5.6	38.4	53.7	3 1/2 X 8 5/8
<b>420 Vdc (470 Vdc Surge)</b>						
1,600	500R162M420BC2B	81.0	64.8	6.7	9.4	2 X 4 1/8
1,700	500R172M420BD2B	75.0	60.0	7.7	10.7	2 X 4 5/8
1,900	500R192M420CJ2E	71.0	56.8	7.2	10.1	2 1/2 X 3 5/8
2,100	500R212M420BE2B	62.0	49.6	8.7	12.2	2 X 5 1/8
2,200	500R222M420BF2B	58.0	46.4	9.2	12.9	2 X 5 5/8
2,400	500R242M420CC2E	58.0	46.4	8.6	12.0	2 1/2 X 4 1/8
2,600	500R262M420CD2E	50.0	40.0	9.6	13.5	2 1/2 X 4 5/8
2,800	500R282M420CE2E	46.0	36.8	10.2	14.3	2 1/2 X 5 1/8
2,800	500R282M420DJ2E	49.0	39.2	10.7	14.9	3 X 3 5/8
3,400	500R342M420CF2E	39.0	31.2	11.5	16.1	2 1/2 X 5 5/8
3,400	500R342M420DC2E	40.0	32.0	12.2	17.1	3 X 4 1/8
3,600	500R362M420CP2E	37.0	29.6	12.8	18.0	2 1/2 X 5 7/8
4,000	500R402M420DD2E	35.0	28.0	13.4	18.7	3 X 4 5/8
4,500	500R452M420DE2E	29.0	23.2	15.2	21.3	3 X 5 1/8
4,900	500R492M420CN2E	27.0	21.6	16.3	22.8	2 1/2 X 7 5/8
4,900	500R492M420DF2E	26.0	20.8	16.7	23.4	3 X 5 5/8
5,000	500R502M420FC2E	28.0	22.4	15.3	21.4	3 1/2 X 4 1/8
5,200	500R522M420DP2E	26.0	20.8	17.1	23.9	3 X 5 7/8
5,500	500R552M420FD2E	26.0	20.8	16.8	23.5	3 1/2 X 4 5/8
5,900	500R592M420CG2E	23.0	18.4	18.6	26.1	2 1/2 X 8 5/8
6,400	500R642M420FE2E	22.0	17.6	19.9	27.9	3 1/2 X 5 1/8
6,600	500R662M420DN2E	20.0	16.0	20.3	28.4	3 X 7 5/8
7,400	500R742M420FF2E	18.0	14.4	23.0	32.2	3 1/2 X 5 5/8
7,800	500R782M420DG2E	17.0	13.6	22.8	31.9	3 X 8 5/8
8,000	5050C83M420FP2E	17.0	13.6	24.5	34.3	3 1/2 X 5 7/8
8,600	500R862M420FN2E	16.0	12.8	27.4	38.4	3 1/2 X 7 5/8
11,000	500R113M420FG2E	13.0	10.4	32.8	46.0	3 1/2 X 8 5/8

# Type 500R 85 °C High Ripple Current, Inverter Grade, Aluminum

## New Higher Ripple Current than Type 500C Screw Terminal Type

Cap (µF)	Catalog Part Number	ESR Max. 25 °C		Ripple Amps. 85 °C		Nominal Size D x L (in)
		120 Hz (mΩ)	10kHz (mΩ)	120 Hz (A)	>3 kHz (A)	
<b>450 Vdc (500 Vdc Surge)</b>						
1400	500R142M450BC2B	104	83.2	6.0	8.4	2 X 4 1/8
1600	500R162M450BD2B	89	71.2	7.0	9.8	2 X 4 5/8
1900	500R192M450BE2B	73	58.4	8.1	11.4	2 X 5 1/8
2000	500R202M450BF2B	71	56.8	8.4	11.8	2 X 5 5/8
2000	500R202M450CJ2E	72	57.6	7.9	11.0	2 1/2 X 3 5/8
2500	500R252M450CC2E	55	44.0	9.6	13.5	2 1/2 X 4 1/8
2700	500R272M450CD2E	51	40.8	10.2	14.3	2 1/2 X 4 5/8
2900	500R292M450DJ2E	50	40.0	10.5	14.8	3 X 3 5/8
3100	500R312M450CE2E	45	36.0	11.1	15.5	2 1/2 X 5 1/8
3500	500R352M450CF2E	40	32.0	12.0	16.8	2 1/2 X 5 5/8
3600	500R362M450DC2E	41	32.8	12.1	16.9	3 X 4 1/8
3700	500R372M450CP2E	38	30.4	13.4	18.7	2 1/2 X 5 7/8
4200	500R422M450DD2E	35	28.0	13.4	18.7	3 X 4 5/8
4700	500R472M450DE2E	30	24.0	14.9	20.9	3 X 5 1/8
5200	500R522M450CN2E	27	21.6	17.0	23.8	2 1/2 X 7 5/8
5200	500R522M450DF2E	26	20.8	17.0	23.8	3 X 5 5/8
5500	500R552M450FC2E	29	23.2	15.0	21.0	3 1/2 X 4 1/8
5600	500R562M450DP2E	26	20.8	18.0	25.2	3 X 5 7/8
5900	500R592M450FD2E	25	20.0	17.1	24.0	3 1/2 X 4 5/8
6200	500R622M450CG2E	23	18.4	19.3	27.0	2 1/2 X 8 5/8
6900	500R692M450DN2E	21	16.8	21.0	29.4	3 X 7 5/8
6900	500R692M450FE2E	22	17.6	19.9	27.9	3 1/2 X 5 1/8
7800	500R782M450FF2E	21	16.8	21.3	29.8	3 1/2 X 5 5/8
8000	5050C83M450FP2E	19	15.2	23.2	32.5	3 1/2 X 5 7/8
8200	500R822M450DG2E	17	13.6	23.0	32.2	3 X 8 5/8
9400	500R942M450FN2E	17	13.6	26.1	36.6	3 1/2 X 7 5/8
11000	500R113M450FG2E	13	10.4	32.4	45.3	3 1/2 X 8 5/8

Cap (µF)	Catalog Part Number	ESR Max. 25 °C		Ripple Amps. 85 °C		Nominal Size D x L (in)
		120 Hz (mΩ)	10kHz (mΩ)	120 Hz (A)	>3 kHz (A)	
<b>500 Vdc (550 Vdc Surge)</b>						
1100	500R112M500BC2B	136	108.8	5.3	7.4	2 X 4 1/8
1300	500R132M500BD2B	115	92.0	6.0	8.3	2 X 4 5/8
1500	500R152M500BE2B	98	78.4	6.7	9.4	2 X 5 1/8
1600	500R162M500CJ2E	93	74.4	6.8	9.5	2 1/2 X 3 5/8
1800	500R182M500BF2B	79	63.2	7.7	10.8	2 X 5 5/8
2000	500R202M500CC2E	76	60.8	8.1	11.4	2 1/2 X 4 1/8
2200	500R222M500CD2E	70	56.0	8.5	11.9	2 1/2 X 4 5/8
2300	500R232M500DJ2E	68	54.4	9.0	12.6	3 X 3 5/8
2400	500R242M500CE2E	62	49.6	9.3	13.0	2 1/2 X 5 1/8
2800	500R282M500CF2E	55	44.0	10.5	14.7	2 1/2 X 5 5/8
2800	500R282M500DC2E	54	43.2	10.5	14.7	3 X 4 1/8
2900	500R292M500CP2E	52	41.6	10.9	15.3	2 1/2 X 5 7/8
3300	500R332M500DD2E	48	38.4	11.2	15.7	3 X 4 5/8
3700	500R372M500DE2E	41	32.8	12.6	17.6	3 X 5 1/8
3700	500R372M500FC2E	42	33.6	13.0	18.1	3 1/2 X 4 1/8
4100	500R412M500CN2E	38	30.4	14.3	20.1	2 1/2 X 7 5/8
4100	500R412M500DF2E	37	29.6	13.9	19.4	3 X 5 5/8
4200	500R422M500FD2E	37	29.6	14.5	20.3	3 1/2 X 4 5/8
4400	500R442M500DP2E	35	28.0	14.3	20.0	3 X 5 7/8
4900	500R492M500CG2E	32	25.6	16.4	22.9	2 1/2 X 8 5/8
5400	500R542M500FE2E	29	23.2	17.2	24.0	3 1/2 X 5 1/8
5600	500R562M500FF2E	26	20.8	19.1	26.7	3 1/2 X 5 5/8
5700	500R572M500DN2E	25.971	20.8	19.2	26.9	3 X 7 5/8
6000	5050C63M500FP2E	26	20.8	20.0	27.9	3 1/2 X 5 7/8
6800	500R682M500DG2E	23	18.4	23.0	32.2	3 X 8 5/8
8200	500R822M500FN2E	18	14.4	25.7	35.9	3 1/2 X 7 5/8
8800	500R882M500FG2E	17	13.6	26.8	37.6	3 1/2 X 8 5/8

# Type 500R 85 °C High Ripple Current, Inverter Grade, Aluminum

New Higher Ripple Current than Type 500C Screw Terminal Type

## Typical Performance Curves

