

10 Watt WD Dual "Low Input" Series DC/DC Converters



Features

- Universal 9 to 36 Volt Input Range.
- Up to 10 Watts of PCB Mounted Power
- Efficiencies to > 80%
- Optional ON/OFF Control Pin
- Fully Isolated, Filtered Design
- Low Noise Outputs
- Very Low I/O Capacitance, 350 pF Typical
- Water Washable Shielded Copper Case
- Five Year Warranty

Description

The universal input of the WD Dual series spans 9 to 36 volts. This makes these converters ideal for 12, 24 and 28 volt battery and process control applications.

Coupled with these features is a low output noise of typically less than 80 mV peak to peak. The noise is also fully specified for RMS value and if even these impressive noise figures aren't enough, our applications section shows a simple add on circuit that can reduce the output noise to less than 10 mV p-p.

Full isolation is provided to help cut ground loops in industrial systems, where unknown input power quality could create havoc with sensitive, high precision analog circuitry.

No extra components or heatsinking are required for most applications saving you design time and valuable PCB space.

Selection Chart					
Model	Input Range VDC		Output		
	Min	Max	VDC	mA	Power W
24D5.850WD	9	36	±5	±850	9
24D12.400WD	9	36	±12	±400	10
24D15.320WD	9	36	±15	±320	10

What all this means to you is a tighter, more compact overall system that has the capability of being universally powered. Full application information is provided to make integrating this supply in your system a snap.

Other input and output voltage combinations may be factory ordered, contact CALEX applications engineering at 1-800-542-3355 for more information.

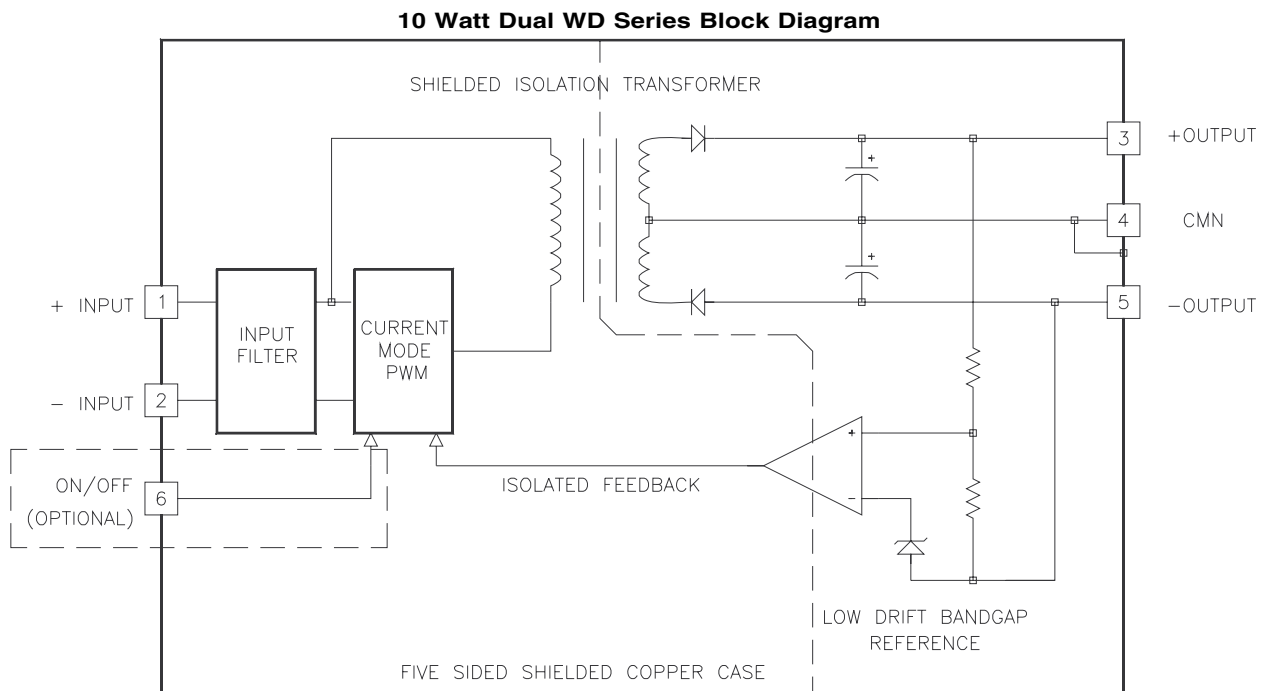

10 Watt WD Dual "Low Input" Series DC/DC Converters

Input Parameters*					
Model		24D5.850WD	24D12.400WD	24D15.320WD	Units
Voltage Range	MIN	9			VDC
	MAX	36			
Input Current	Full Load	450	510	510	mA
	No Load	10	15	15	
Efficiency	TYP	79	78	78	%
Switching Frequency	TYP	100			kHz
Maximum Input Overvoltage, 100ms Maximum	MAX	40			VDC
Turn-on Time, 1% Output Error	TYP	10	20	20	ms
Recommended Fuse		(2)			

Output Parameters*					
Model		24D5.850WD	24D12.400WD	24D15.320WD	Units
Output Voltage		±5	±12	±15	VDC
Output Voltage Accuracy	MIN	±4.950	±11.900	±14.900	VDC
	TYP	±5.000	±12.000	±15.000	
	MAX	±5.050	±12.100	±15.100	
Rated Load Range (3)	MIN	0	0	0	mA
	MAX	±850	±400	±320	
Load Regulation (4) 25% Max load to Max Load	TYP	0.1	0.1	0.1	%
	MAX	0.5	0.5	0.5	
Cross Regulation (5)	TYP	2.5	1.2	1.0	%
Line Regulation Vin = 9 - 36 VDC	TYP	0.1	0.1	0.1	%
	MAX	0.7	0.3	0.3	
Short Term Stability (6)	TYP	< 0.01			%/24Hrs
Long Term Stability	TYP	< 0.1			%/kHrs
Noise, Peak - Peak (1)	TYP	100	70	60	mV P-P
RMS Noise	TYP	30	20	15	mV RMS
Temperature Coefficient	TYP	50			ppm/°C
	MAX	250			
Short Circuit Protection		Short Term Current Limit			

NOTES

* **All parameters measured at Tc = 25°C, nominal input voltage and full rated load unless otherwise noted. Refer to the CALEX Application Notes for the definition of terms, measurement circuits and other information.**

- (1) Noise is measured per CALEX application notes. Measurement bandwidth is 0-20 MHz. RMS noise is measured over a 0.01-1 MHz bandwidth. To simulate standard PCB decoupling practices, output noise is measured with a 10µf tantalum and 0.01µF ceramic capacitor located 1 inch away from the converter.
- (2) See our application note for picking the correct fuse size.
- (3) The converter may be safely operated at any load from zero to the full rating. Dynamic response of the converter may degrade if the converter is operated with less than 25% output load.
- (4) Load regulation is defined for loading/unloading both outputs simultaneously. Load range is 25 to 100%.
- (5) Cross regulation is defined for loading/unloading one output while the other output is kept at full load. Load range is 25 to 100%.
- (6) Short term stability is specified after a 30 minute warmup at full load, constant line and recording the drift over a 24 hour period.
- (7) Case is tied to the CMN output pin.
- (8) The functional temperature range is intended to give an additional data point for use in evaluating this power supply. At the low functional temperature the power supply will function with no side effects, however sustained operation at the high functional temperature may reduce the expected operational life. The data sheet specifications are not guaranteed over the functional temperature range.
- (9) The case thermal impedance is specified as the case temperature rise over ambient per package watt dissipated.
- (10) See the applications section for more information on applying the ON/OFF pin.
- (11) Specifications subject to change without notice.
- (12) Water Washability - Calex DC/DC converters are designed to withstand most solder/wash processes. Careful attention should be used when assessing the applicability in your specific manufacturing process. Converters are not hermetically sealed.

10 Watt WD Dual "Low Input" Series DC/DC Converters

General Specifications*			
All Models			Units
ON/OFF Function			
OFF Logic Level or Tie Pin to -Input (10)	MAX	< 0.4	VDC
Open Circuit Voltage	TYP	1.4	VDC
Input Resistance	TYP	2	kohms
Converter Idle Current ON/OFF Pin Low	TYP	6	mA
Isolation (7)			
Isolation Voltage Input to Output 10µA Leakage	MIN	700	VDC
Input to Output Capacitance	TYP	350	pF
Environmental			
Case Operating Range	MIN	-40	°C
	MAX	85	
Case Functional Range (8)	MIN	-50	°C
	MAX	100	
Storage Range	MIN	-55	°C
	MAX	105	
Thermal Impedance (9)	TYP	16	°C/Watt
Unit Weight	TYP	1.2	oz
Mounting Options			
PCB Mounting Kits	MS6, MS8, MS15		
Optional ON/OFF			
- O Suffix on part Number	ON/OFF		

Applications Information

You truly get what you pay for in a CALEX converter, a complete system oriented and specified DC/DC converter - no surprises, no external noise circuits needed, no heatsinking problems, just "plug and play".

The WD Dual series like all CALEX converters carries the full 5 year CALEX no hassle warranty. We can offer a five year warranty where others can't because with CALEX it's rarely needed.

Keep reading, you'll find out why.

General Information

The universal 9 to 36 volt input allows you to specify your system for operation from any 12, 24 or 28 volt nominal input.

Five sided shielding is standard along with specified operation over the full industrial temperature range of -40 to +85°C case temperature.

Applying the Input

Figure 1 shows the recommended input connections for the WD Dual DC/DC converter. A fuse is recommended to protect the input circuit and should not be omitted. The fuse serves to prevent unlimited current from flowing in the case of a catastrophic system failure.

When using the WD Dual be sure that the impedance at the input to the converter is less than about 0.15 ohms at 100 kHz, this is usually not a problem in battery powered systems when the converter is connected directly

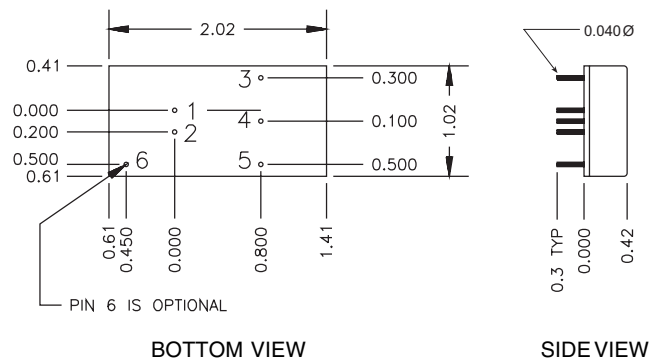

Mechanical tolerances unless otherwise noted:

X.XX dimensions: ±0.03 inches

X.XXX dimensions: ±0.005 inches

Pin location shown is for the mating PCB

Pin	Function
1	+ INPUT
2	- INPUT
3	+ OUTPUT
4	CMN
5	- OUTPUT
6	ON/OFF

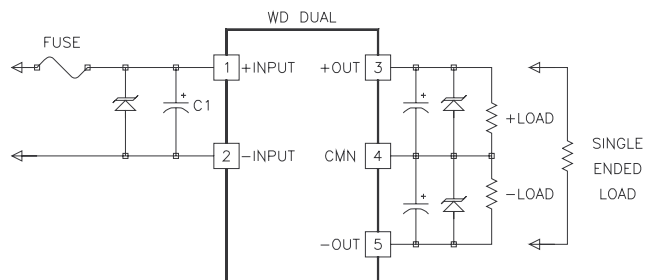

Figure 1.

If the source impedance driving the WD Converter is more than about 0.15 ohms at 100 kHz the optional capacitor C1 may be required (See text for more information). Optional transient protector diodes may be used if desired for added input and output protection. The fuse serves as a catastrophic failure protector and should not be omitted.

to the battery. If the converter is located more than about 1-2 inches from the input source an added capacitor may be required. This capacitor should be connected directly at the input pins for proper operation.

The maximum permissible source impedance is a function of output power and line voltage. The impedance can be higher when operating at less than full power. The minimum impedance is required when operating with a 9 volt input at full load. The impedance reduces as the input voltage is raised or

10 Watt WD Dual "Low Input" Series DC/DC Converters

the power is reduced. In general you should keep the peak to peak voltage measured across the input pins less than 0.25 volts (p-p) (not including the high frequency spikes) for maximum converter performance.

There is no lower limit on the allowed source impedance, it can be any physically realizable value, even approaching 0.

If the source impedance is too large in your system you should choose an external input capacitor as detailed below.

Picking An External Input Capacitor

If an input capacitor is needed at the input to the converter it must be sized correctly for proper converter operation. The curve "RMS Input Current Vs Line Input" shows the RMS ripple current that the input capacitor must withstand with varying loading conditions and input voltages.

Several system tradeoffs must be made for each particular system application to correctly size the input capacitor.

The probable result of undersizing the capacitor is increased self heating, shortening it's life. Oversizing the capacitor can have a negative effect on your products cost and size, although this kind of overdesign does not result in shorter life of any components.

There is no one optimum value for the input capacitor. The size and capacity depend on the following factors:

- 1) Expected ambient temperature and your temperature derating guidelines.
- 2) Your ripple current derating guidelines.
- 3) The maximum anticipated load on the converter.
- 4) The input operating voltage, both nominal and excursions.
- 5) The statistical probability that your system will spend a significant time at any worst case extreme.

Factors 1 and 2 depend on your system design guidelines. These can range from 50 to 100% of the manufacturers listed maximum rating, although the usual derating factor applied is about 70%. 70% derating means if the manufacturer rated the capacitor at 1 A RMS you would not use it over 0.7 A RMS in your circuit.

Factors 3 and 4 realistically determine the worst case ripple current rating required for the capacitor along with the RMS ripple current curve.

Factor 5 is not easy to quantify. At CALEX we can make no assumptions about a customers system so we leave to you the decision of how you define how big is big enough.

Suitable capacitors for use at the input of the converter are given at the end of this section.

Very Low Noise Input Circuit

Figure 2 shows a very low noise input circuit that may be used with the converters. This circuit will reduce the input reflected ripple current to less than 100 mA peak-peak ($V_{in} = 24 V$, 20 MHz bw). See the discussion above for the optimum selection of C1.

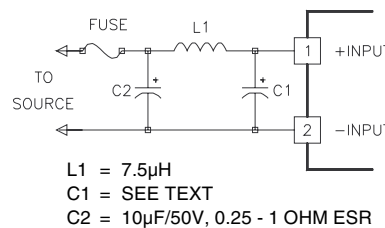

Figure 2.

This circuit will reduce the input reflected ripple current to less than 100 mA peak to peak. See the discussion in the text for help on the optimum selection of C1. L1 should be sized to handle the maximum input current at your lowest operating voltage and maximum expected output power.

Suggested Capacitor Sources

These capacitors may be used to lower your sources input impedance at the input of the converter. These capacitors will work for 100% load, worst case input voltage and ambient temperature extremes. They however, may be oversized for your exact usage, see "Picking An External Input Capacitor" above for more information. You may also use several smaller capacitors in parallel to achieve the same ripple current rating. This may save space in some systems.

United Chemi-Con LXF, SXE, RXC, RZ and RZA series
Suggested Part: LXF50VB120M8X20LL
120μF, 50V, 105°C RATED
ESR=0.14 OHMS
Allowable Ripple at 85°C = 1.0A

Nichicon PR and PF series
Suggested Part: UPR1H470MPH
470μF, 50V, 105°C RATED
ESR=0.1 OHMS
Allowable Ripple at 85°C = 1.0A

Panasonic HFG, HFQ, HFZ Series
Suggested Part: ECA1HFQ151
150μF, 50V, 105°C RATED
ESR=0.16 OHMS
Allowable Ripple at 85°C = 1.0A

Remote ON/OFF (Optional)

The WD dual series has an optional Remote ON/OFF pin. This option allows a control signal to place the WD Dual in a very low power state (<6 mA TYP).

Do not drive this input from a logic gate directly. The ON/OFF pin must be left floating to turn the converter ON and allow normal operation. This input is noise sensitive and should not be routed all over your PCB.

When the ON/OFF pin is pulled low with respect to the -Input pin the converter is placed in a low power drain state. The ON/OFF pin turns the converter off while keeping the input bulk capacitors fully charged. Using the ON/OFF pin to control the WD's operation prevents the large inrush current that would be experienced if the +Input pin was opened and closed.

The ON/OFF pin should never be pulled more than -0.3 volts below the -Input pin or have a voltage of greater than +3 volts applied to it.

10 Watt WD Dual "Low Input" Series DC/DC Converters

Applying the Output

Figure 1 shows typical output connections for the WD Dual. In most applications no external output capacitance will be necessary. Only your normal 1 to 10 uF tantalum and 0.001 to 0.1 uF ceramic bypass capacitors sprinkled around your circuit as needed locally are required. Do not add extra output capacitance and cost to your circuit "Just Because".

If you feel you must add external output capacitance, do not use the lowest ESR, biggest value capacitor that you can find! This can only lead to reduced system performance or oscillation. See our application note "Understanding Output Impedance For Optimum Decoupling" for more information, and by all means use our factory tested low noise circuit provided.

Ultra Low Noise Output Circuit

The circuit shown in figure 3 can be used to reduce the output noise to below 10 mV p-p over a 20 MHz bandwidth. Size inductor L1 appropriately for the maximum expected load current. All of the ground connections must be as short as possible back to the CMN pin. The filter should be placed as close to the WD Dual as possible, even if your load is at some distance from the converter.

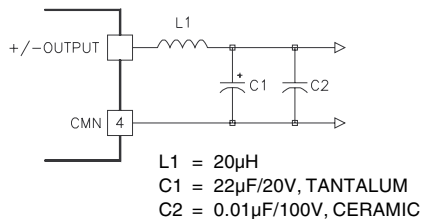

Figure 3.

This circuit can reduce the output noise to below 10 mV p-p over a 20 MHz bandwidth. Size inductor L1 appropriately for the maximum expected load current. The filter should be constructed as close as possible to the converter and all of the ground connections must be as short as possible back to the CMN pin.

Single Ended Loads

The WD Dual may be operated as a single ended output to get either 10, 24 or 30 volts output as shown in figure 1. If the output is operated single ended then the CMN pin should be left floating.

Full power is available when operating single ended. For example: If a 24D5.850WD is operated as a 10 volt output then a full 0.850 amps is available at 10 volts.

Operation With Very Light Loads

Dynamic response and cross regulation of the WD Dual will degrade when the unit is operated with less than about 25% of full rated power. If this is a problem the most lightly loaded output may be "Pre-Loaded" with a resistor to common as needed. The exact amount of preloading required is dependent on your system requirements, so some experimentation is necessary to arrive at the optimum value.

Grounding

The input and output sections are fully floating from each other. They may be operated fully floating or with a common

ground. If the input and output sections are connected either directly at the converter or at some remote location from the converter it is suggested that a 1 to 10 uF, 0.5 to 5 Ohm ESR capacitor bypass be used directly at the converters output pins. These capacitors prevent any common mode switching currents from showing up at the converters output as normal mode output noise. See "Applying the Output" for more information on selecting output capacitors.

Also see the CALEX application note "Dealing With Common Mode Noise" for more information on using common grounds.

Case Grounding

The copper case serves not only as a heat sink but also as a EMI shield. The 0.017 inch thick case provides >20 dB of absorption loss to both electric and magnetic fields at 100 kHz, while at the same time providing 20 to 40 % better heat sinking over competitive thin steel, aluminum or plastic designs.

The case shield is tied to the CMN output pin. This connection is shown on the block diagram. The case is floating from the input sections. The input is coupled to the outputs only by the low 350 pF of isolation capacitance. This low I/O capacitance insures that any AC common mode noise on the inputs is not coupled to your output circuits.

Compare this isolation to the more usual 1000 - 2000 pF found on competitive designs and you will see that CALEX provides the very best DC and AC isolation available. After all, you are buying an isolated DC/DC to cut ground loops. Don't let the isolation capacitance add them back in.

Temperature Derating

The WD Dual series can operate up to 85°C case temperature without derating. Case temperature may be roughly calculated from ambient by knowing that the case temperature rise is approximately 16°C per package watt dissipated.

For example: If a WD Dual converter is delivering 8 Watts with a 24 volt input, at what ambient could it expect to run with no moving air and no extra heatsinking?

Efficiency of the converter is approximately 76% at 8 watts of output power, this leads to an input power of about 10.5 Watts. The case temperature rise would be 10.5 - 8 Watts or 2.5 Watts \times 16 = 40°C. This number is subtracted from the maximum case temperature of 85°C to get: 45°C.

This example calculation is for a WD Dual without any extra heat sinking or appreciable air flow. Both of these factors can greatly effect the maximum ambient temperature (see below). Exact efficiency depends on input line and load conditions, check the efficiency curves for exact information.

This is a rough approximation to the maximum ambient temperature. Because of the difficulty of defining ambient temperature and the possibility that the loads dissipation may actually increase the local ambient temperature significantly, these calculations should be verified by actual measurement before committing to a production design.

Remember, it is the system designers responsibility to be sure that the case temperature of the WD Dual does not exceed 85°C for maximum reliability in operation.

10 Watt WD Dual "Low Input" Series DC/DC Converters

Typical Performance ($T_c=25^\circ\text{C}$, $V_{in}=\text{Nom VDC}$, Rated Load).

