

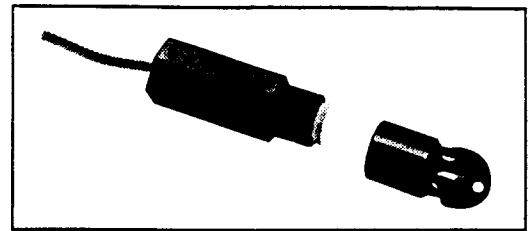

**LV170**  
**Electro-Optic Level Switch**  
**Instruction Sheet**

M1934/1194



---

**Read all instructions before beginning - Follow all safety precautions**

When installed in accordance with this guide, the sensor is suitable for use in Class I, Division 1, Groups C and D.

10 - 28 Vdc Input Voltage Versions

**WARNING**

The nature of the sensor is that it is a non-voltage producing device, containing limited energy-storing components. However, since its primary use is in a hazardous location, an appropriate intrinsically safe interface device must be used and installed in strict accordance with the National Electrical Code and the applicable instruction sheets. Failure to observe this warning could result in serious injury or damages.

**Unpacking**

Remove the Packing List and verify that you have received all equipment. If you have any questions about the shipment, please call the OMEGA Customer Service Department.

When you receive the shipment, inspect the container and equipment for any signs of damage. Note any evidence of rough handling in transit. Immediately report any damage to the shipping agent.

**NOTE**

The carrier will not honor any claims unless all shipping material is saved for their examination. After examining and removing contents, save packing material and carton in the event reshipment is necessary.

---

**Description**

The OMEGA® LV170 Series Optical Liquid Sensors accurately detect the presence of liquid in fiberglass double-wall tanks, containment sumps and double-wall pipes. Built-in electronic switching ensures dependability throughout its long service life. This reusable sensors easily fits small, interstitial spaces and senses liquid hydrocarbons or water. The units are unaffected by hydrocarbon vapors, thereby greatly reducing the risk of false alarms. The sensors are easy to remove, clean and reinstall after an alarm condition is triggered, or for maintenance.

Available models are LV171 (wet probe sensor) and LV172 (dry probe sensor).

---

**Sensor Operating Principle**

The sensor contains an infrared LED source and a phototransistor detector. Light from the LED is directed into a prism, which forms the tip of the sensor. With no liquid present, light from the LED is reflected within the prism to the phototransistor. When rising liquid immerses the prism, the light is refracted out of the prism, leaving little or no light to reach the detector. Sensing this change, the detector actuates electronic switching with the unit to operate an external alarm or control circuit.

---

**Installation**

- Use Teflon-coated (TFE) thread tape to seal thread.

**Caution**

Pipe sealant must not come in contact with prism surface.

- Thread sensor into tank wall and tighten by hand. Further tighten an additional one to two threads past hand-tightness. (Avoid overtightening, as this may damage threads).
- Sensor may be installed in exactly horizontal or vertical positions, only.
- Do not install sensor close to infrared sources.
- Prism surface must be at least 2" from any reflective surfaces.
- Connect 10 - 28 Vdc ( $\pm 10\%$ ) power to red lead; return (-) to black lead.

# Zener Barrier Wiring Diagram

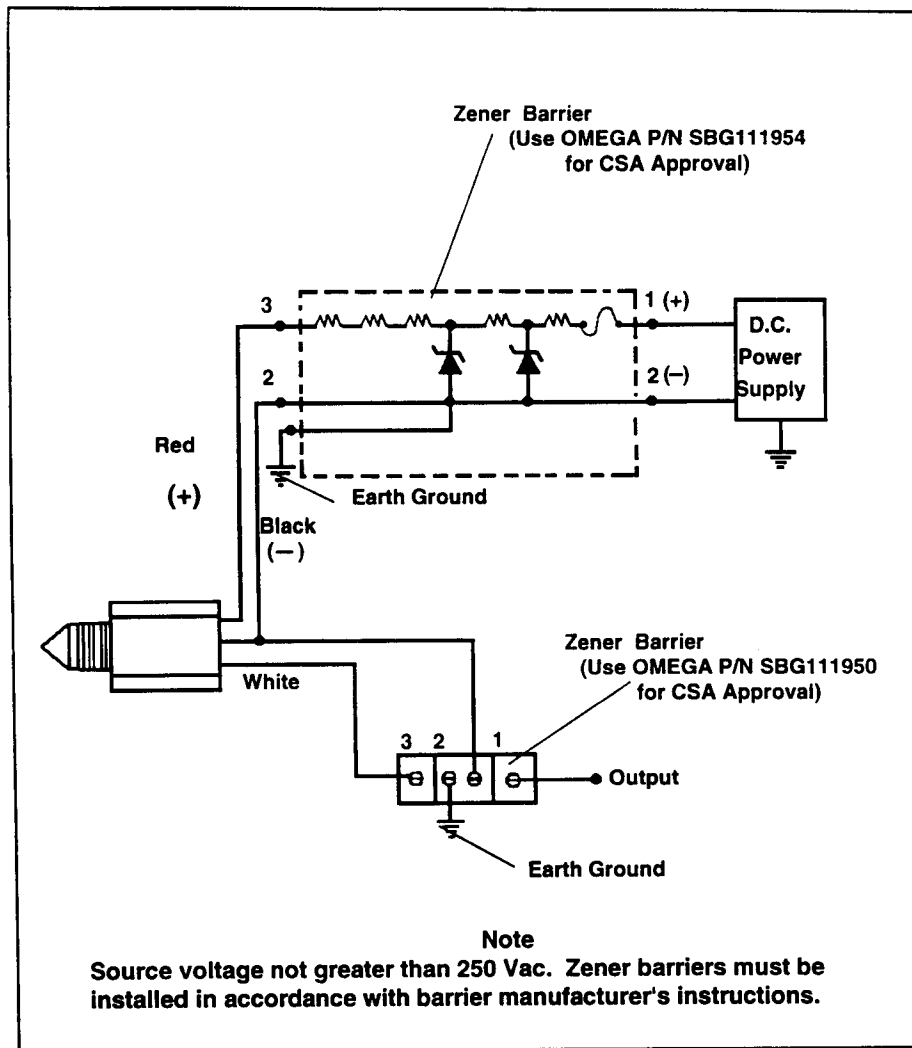

## Typical Mounting Positions

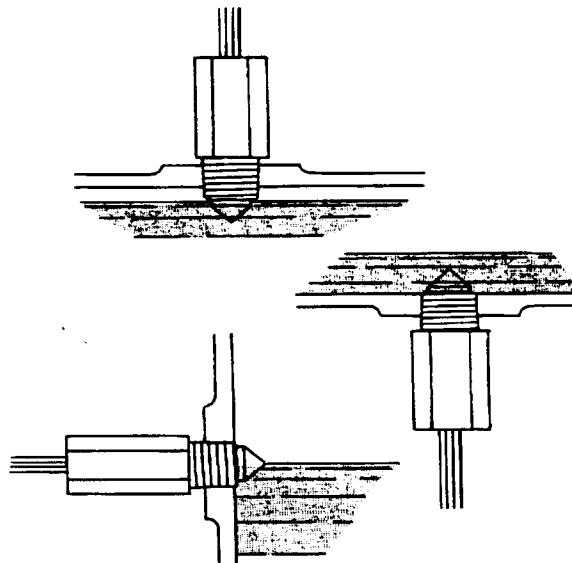

**Note**  
 Units must be mounted exactly vertically or horizontally.

## Running of Field Wire

- A. The conductors of the intrinsically safe circuit should be sealed in a rigid metal conduit at the point where the wiring enters the hazardous area. The wiring and contacting device should be such that conductive dusts in the area will not close the circuit in place of the contacts.
- B. Hazardous area field wiring will store energy due to distributed capacitance and inductance in proportion to its length. The maximum run of cable has been defined at 750 feet between barrier and sensor.

For CSA intrinsic safety approval, the following barriers must be used: SBG111950 and SBG111954

U.L. Entity Parameters

Terminal	V <sub>max</sub>	I <sub>max</sub>	C <sub>1</sub>	L <sub>1</sub>
Red/Black	38V	150mA	.052μf	0
White/Black	38V	150mA	.052μf	0

$$V_{max} \geq V_{oc}(\text{barrier})$$

$$I_{max} \geq I_{sc}(\text{barrier})$$

$$C_1 + C_{\text{cable}} \leq C_A(\text{barrier})$$

$$L_1 + L_{\text{cable}} \leq L_A(\text{barrier})$$

- C. Shielded cable is not required, but if used in the application, the shield must be returned to ground. The shield must be connected to barrier earth ground.
- D. Intrinsically safe wiring must be installed in accordance with Article 504 of the NEC, ANSI/NFPA-70 or CEC Part 1, as applicable. All intrinsically safe wiring must have 0.01 inch minimum insulation thickness. Non-intrinsically safe wiring cannot be run in conduit or open raceways together with intrinsically safe wiring.

## Maintenance

Sensor may require a periodic cleaning of prism surface. Chlorinated hydrocarbons must not be used for cleaning. A mild detergent may be used to clean prism surface.

## Specifications

Wetted Materials:	Polysulfone body, PVC pull ring, Epoxy back-filled at wires
Operating Temperature:	
10-28Vdc:	32° to 158°F (0°C to 70°C)
Current Consumption:	17mA, approx.
Output:	TTL/CMOS compatible, may sink up to 40mA
Temperature Range:	0°F to 176°F (-17.8°C to 80°C) - (not for use in freezing liquids)
Pressure Range:	0 to 150 PSI maximum
Cable:	Three (3) conductor, PVC jacketed (25 feet extended)
Approvals:	UL Classified for Class I, Group C and D Hazardous Locations

## Dimensions

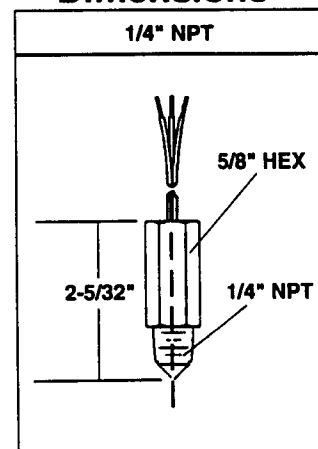

# NOTES



## WARRANTY

OMEGA warrants this unit to be free of defects in materials and workmanship and to give satisfactory service for a period of **13 months** from date of purchase. OMEGA Warranty adds an additional one (1) month grace period to the normal **one (1) year product warranty** to cover handling and shipping time. This ensures that OMEGA's customers receive maximum coverage on each product. If the unit should malfunction, it must be returned to the factory for evaluation. OMEGA's Customer Service Department will issue an Authorized Return (AR) number immediately upon phone or written request. Upon examination by OMEGA, if the unit is found to be defective it will be repaired or replaced at no charge. However, this WARRANTY is VOID if the unit shows evidence of having been tampered with or shows evidence of being damaged as a result of excessive corrosion; or current, heat, moisture or vibration; improper specification; misapplication; misuse or other operating conditions outside of OMEGA's control. Components which wear or which are damaged by misuse are not warranted. These include contact points, fuses, and triacs.

OMEGA is glad to offer suggestions on the use of its various products. Nevertheless, OMEGA only warrants that the parts manufactured by it will be as specified and free of defects.

OMEGA MAKES NO OTHER WARRANTIES OR REPRESENTATIONS OF ANY KIND WHATSOEVER, EXPRESSED OR IMPLIED, EXCEPT THAT OF TITLE AND ALL IMPLIED WARRANTIES INCLUDING ANY WARRANTY OF MERCHANTABILITY AND FITNESS FOR A PARTICULAR PURPOSE ARE HEREBY DISCLAIMED. LIMITATION OF LIABILITY: The remedies of purchaser set forth herein are exclusive and the total liability of OMEGA with respect to this order, whether based on contract, warranty, negligence, indemnification, strict liability or otherwise, shall not exceed the purchase price of the component upon which liability is based. In no event shall OMEGA be liable for consequential, incidental or special damages.

Every precaution for accuracy has been taken in the preparation of this manual, however, OMEGA ENGINEERING, INC. neither assumes responsibility for any omissions or errors that may appear nor assumes liability for any damages that result from the use of the products in accordance with the information contained in the manual.

SPECIAL CONDITION: Should this equipment be used in or with any nuclear installation or activity, purchaser will indemnify OMEGA and hold OMEGA harmless from any liability or damage whatsoever arising out of the use of the equipment in such a manner.

OMEGA's policy is to make running changes, not model changes, whenever an improvement is possible. This affords our customers the latest in technology and engineering.

OMEGA is a registered trademark of OMEGA ENGINEERING, INC.

© Copyright 1994 OMEGA ENGINEERING, INC. All rights reserved including illustrations. This documentation may not be copied, photocopied, reproduced, translated, or reduced to any electronic medium or machine-readable form, in whole or in part, without prior written consent of OMEGA ENGINEERING, INC.

## Servicing USA and Canada: Call OMEGA Toll Free USA Canada

One Omega Drive, Box 4047  
Stamford, CT 06907-0047  
Telephone: (203) 359-1660  
FAX: (203) 359-7700

976 Bergar  
Laval (Quebec) H7L 5A1  
Telephone: (514) 856-6928  
FAX: (514) 856-6886

Sales Service: 1-800-826-6342 / 1-800-TC-OMEGA™  
Customer Service: 1-800-622-2378 / 1-800-622-BEST™  
Engineering Service: 1-800-872-9436 / 1-800-USA-WHEN™  
TELEX: 996404 EASYLINK: 62968934 CABLE: OMEGA

## Servicing Europe: United Kingdom Sales & Distribution Center

25 Swannington Road, Broughton Astley, Leicestershire  
LE9 6TU, England  
Telephone: 44 (1455) 285520 FAX: 44 (1455) 283912

## RETURN REQUESTS / INQUIRIES

Direct all warranty and repair requests/inquiries to the OMEGA ENGINEERING Customer Service Department. BEFORE RETURNING ANY PRODUCT(S) TO OMEGA, PURCHASER MUST OBTAIN AN AUTHORIZED RETURN (AR) NUMBER FROM OMEGA'S CUSTOMER SERVICE DEPARTMENT (IN ORDER TO AVOID PROCESSING DELAYS). The assigned AR number should then be marked on the outside of the return package and on any correspondence.

Please have the following information available BEFORE contacting OMEGA:

1. P.O. number under which the product was purchased,
2. Model and serial number of the product, and
3. Repair instructions and/or specific problems relative to the product.