



Maintenance-Free Rechargeable Sealed Lead-Acid Battery

EP17-12



The battery is constructed by plates, separators, safety valves and container. Since the electrolyte is held by a glass-mat separator and plates, the battery can use in any direction and position without leakage.

PERFORMANCE SPECIFICATIONS

Nominal Voltage(V).....	12 volts(6cells in series)
Nominal Capacity(AH)	
20 Hour rate F.V.(1.75V/cell) (850mA to 10.50volts).....	17.0A.H.
10 Hour rate F.V.(1.75V/cell) (1615mA to 10.50volts)	16.15A.H.
5 Hour rate F.V.(1.75V/cell) (2890mA to 10.50volts)	14.45A.H.
30 Min rate F.V.(1.30V/cell) (17000mA to 7.80volts).....	8.50A.H.
Approximate Weight.....	6200g(13.67lbs.)
Terminal	
Standard.....	Type B1
Optional.....	Type T2,I1
Internal Resistance (Fully Charged Battery).....	<16mΩ
Maximum Discharge Current For 5 sec.(A).....	255A
Maximum Charge Current(A).....	5.1A
Ambient Temperature	
Charge.....	0°C(32°F)~40°C(104°F)
Discharge.....	-20°C(-4°F)~50°C(122°F)
Storage.....	-20°C(-4°F)~40°C(104°F)
Vibration test:	
Frequency: 16.7HZ	
Amplitude: 4mm	
Vibrate the battery horizontally or vertically for 60 minutes. The battery have no abnormality.	
Case.....	ABS
Dimension(mm/inch)	
Length ±1.5mm.....	181/7.13
Width ±1.5mm.....	76/2.99
Container Height ±1.5mm.....	166/6.54
Total Height ±1.5mm.....	166/6.54
Application.....	Fishing Lights, Lawn Mowers, Electrical Bicycle.

EP17-12 Battery discharge characteristics (25 °C/77 °F)

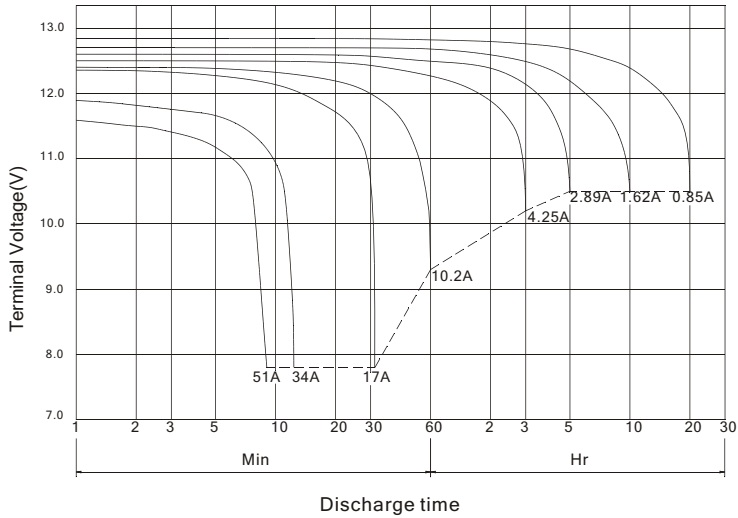

BATTERY CHARGING CHARACTERISTICS (Typical example of the charge characteristics for the cycle use)

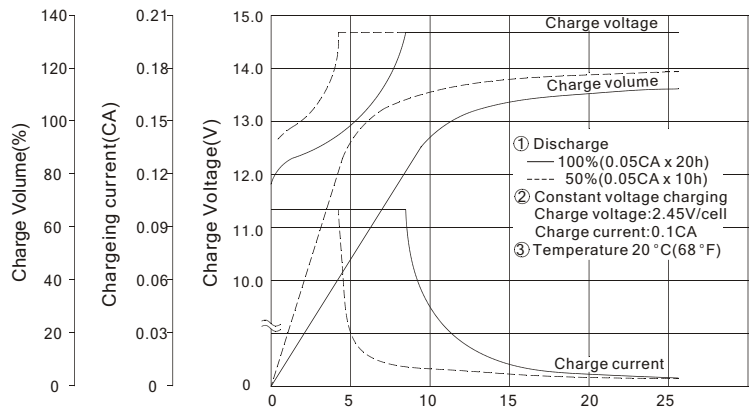

Charging Procedure

Application	Charging method	Charging Voltage at 20 °C (V/cell)	Temperature compensation coefficient of charging voltage (mV/°C/cell)	Max. charging current (CA)	Charging time 0.1CA, 20 °C (h)		Temp (°C)
					100% discharge	50% discharge	
For standby power source	Constant voltage & Constant current charging (with current restriction)	2.25~2.30	-3	0.3	24	20	0~40 (32~104°F)
For cycle service		2.40~2.50	-4	0.3	16	10	

*Temperature compensation of charging voltage is not needed, when using the batteries within 5 °C to 35 °C range.

Battery Life Characteristics of Cyclic Use

Testing Conditions : Discharge Current : 0.25C Amp (F.V. 1.7v/cell)
Charging Current : 0.1C Amp
Charging Volume : 120% OF Discharge Capacity
Ambient Temperature : 20 °C (68 °F)

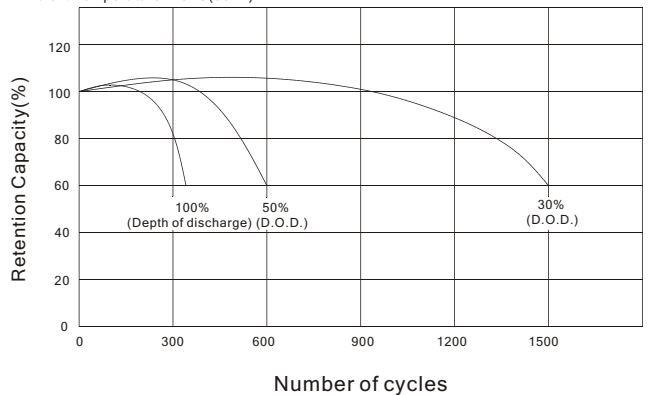

OUTER DIMENSIONS

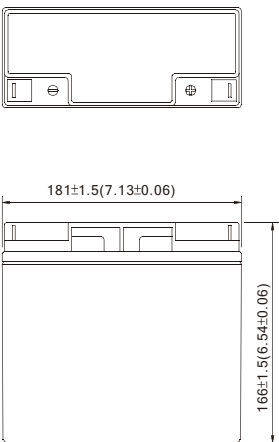

TERMINAL TYPE

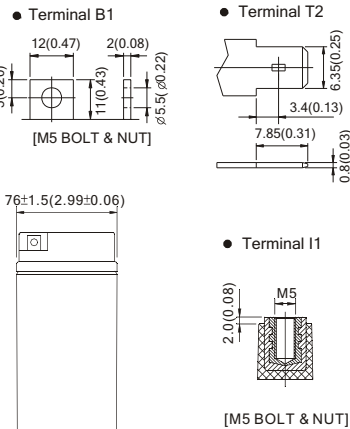

Constant power discharge characteristics at 25°C/77°F

Final Voltage	Discharge time									
	5Min	10Min	15Min	30Min	1Hr	3Hr	5Hr	10Hr	20Hr	
	Battery output power(W)									
10.80V	554	416.3	337.1	202.8	117.5	49.5	34.2	19.09	9.98	
10.50V	641	451.0	352.9	210.6	120.9	50.5	34.7	19.38	10.20	
10.20V	680	467.3	363.6	215.2	123.1	51.0	35.0	19.48	10.25	
9.90V	712	478.4	372.1	218.3	124.8	51.5	35.2	19.53	10.27	
9.60V	733	487.9	379.3	220.5	126.0	51.7	35.2	19.53	10.27	

TERMINAL POSITION

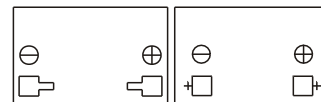

B.B. BATTERY CO., LTD.

Web Site: <http://www.bb-battery.com>

USA:
B&B BATTERY(USA) INC.
6415 RANDOLPH ST.COMMERCE,
CA,90040 U.S.A.
TEL:1-323-278-1900.1-800-278-8599
FAX:1-323-278-1268
E-Mail:sales@bb-battery.com

EUROPE:
B&B BATTERY(EUROPE) B.V.
3 WIJNGAARDVELD, 9300 AALST,BELGIUM
TEL:(00)32-53781567
FAX:(00)32-53781567
E-Mail:hansdevriese@bb-battery.com

CHINA FACTORY:
B.B. BATTERY CO., LTD.
CHENG DONG TRIAL AREA,HUANG GANG,
RAOPING, GUANG DONG,CHINA,515700
TEL:86-768-7601001-2
FAX:86-768-7601469
E-Mail:maggy@bb-battery.com

HONG KONG:
NATIONAL TRADING LTD.
TEL:852-2301-3800
FAX:852-2739-1182
E-Mail:bbhk@hkstar.com

JAPAN:
B&B BATTERY(JAPAN) CO., LTD.
1375-11 NARAHARA-MACHI,HACHIOJI,
TOKYO 193-0803,JAPAN.
TEL:81-426-256-537
FAX:81-426-256-537
E-Mail:miyata@bb-battery.com

TAIWAN:
B.B. BATTERY(TAIWAN) CO., LTD.
TEL:886-6-502-5150
FAX:886-6-589-8087
E-Mail:maggy@bb-battery.com

